



This is a digital copy of a book that was preserved for generations on library shelves before it was carefully scanned by Google as part of a project to make the world's books discoverable online.

It has survived long enough for the copyright to expire and the book to enter the public domain. A public domain book is one that was never subject to copyright or whose legal copyright term has expired. Whether a book is in the public domain may vary country to country. Public domain books are our gateways to the past, representing a wealth of history, culture and knowledge that's often difficult to discover.

Marks, notations and other marginalia present in the original volume will appear in this file - a reminder of this book's long journey from the publisher to a library and finally to you.

### Usage guidelines

Google is proud to partner with libraries to digitize public domain materials and make them widely accessible. Public domain books belong to the public and we are merely their custodians. Nevertheless, this work is expensive, so in order to keep providing this resource, we have taken steps to prevent abuse by commercial parties, including placing technical restrictions on automated querying.

We also ask that you:

- + *Make non-commercial use of the files* We designed Google Book Search for use by individuals, and we request that you use these files for personal, non-commercial purposes.
- + *Refrain from automated querying* Do not send automated queries of any sort to Google's system: If you are conducting research on machine translation, optical character recognition or other areas where access to a large amount of text is helpful, please contact us. We encourage the use of public domain materials for these purposes and may be able to help.
- + *Maintain attribution* The Google "watermark" you see on each file is essential for informing people about this project and helping them find additional materials through Google Book Search. Please do not remove it.
- + *Keep it legal* Whatever your use, remember that you are responsible for ensuring that what you are doing is legal. Do not assume that just because we believe a book is in the public domain for users in the United States, that the work is also in the public domain for users in other countries. Whether a book is still in copyright varies from country to country, and we can't offer guidance on whether any specific use of any specific book is allowed. Please do not assume that a book's appearance in Google Book Search means it can be used in any manner anywhere in the world. Copyright infringement liability can be quite severe.

### About Google Book Search

Google's mission is to organize the world's information and to make it universally accessible and useful. Google Book Search helps readers discover the world's books while helping authors and publishers reach new audiences. You can search through the full text of this book on the web at <http://books.google.com/>





Class S21

Book F7

This One



TOWP-11S-EQ9Q



Class S21

Book F7









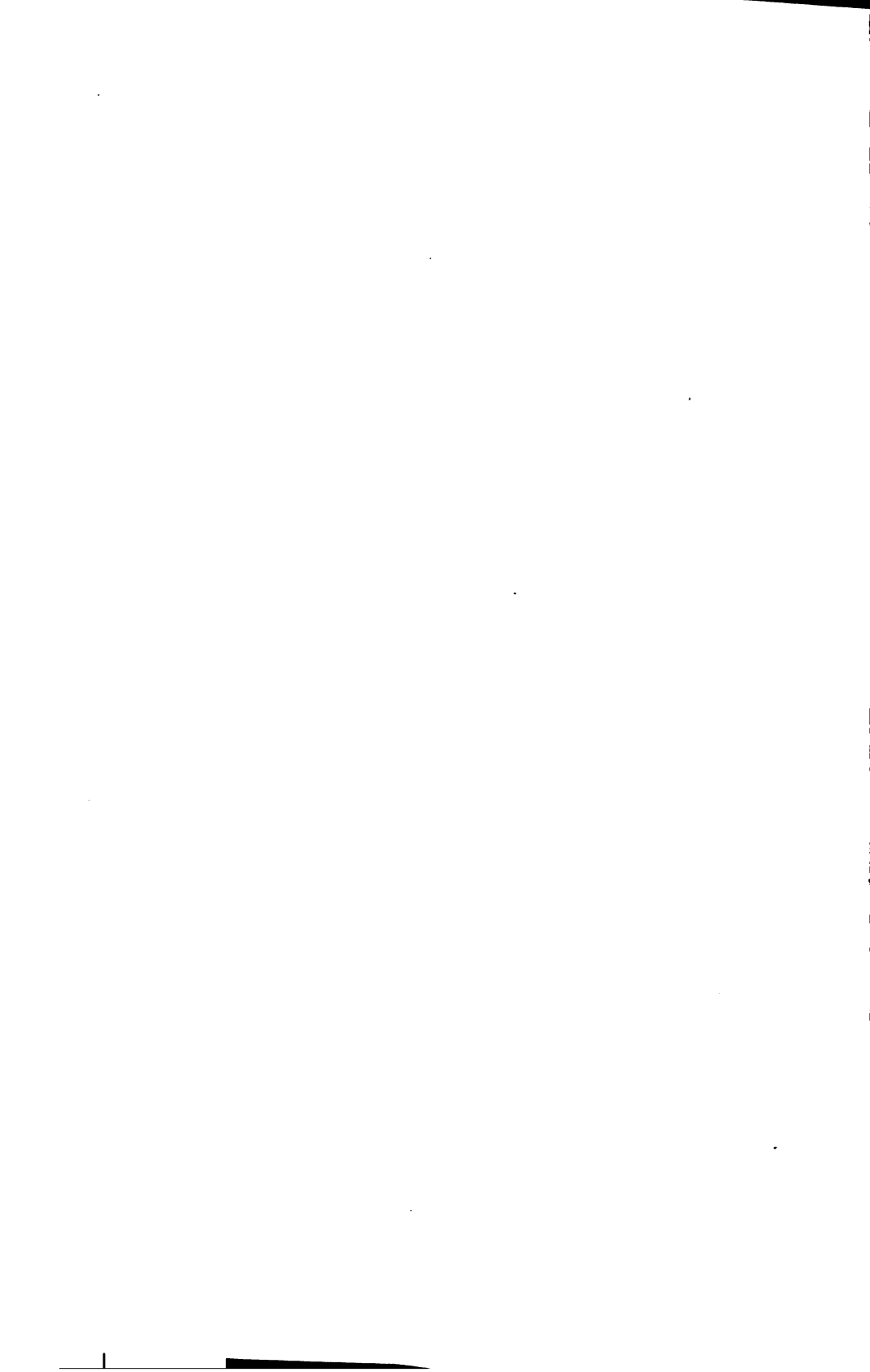

U. S. DEPARTMENT OF AGRICULTURE.

OFFICE OF EXPERIMENT STATIONS—BULLETIN NO. 168.

A. C. TRUE, Director.

---

ANNUAL REPORT OF IRRIGATION AND DRAINAGE  
INVESTIGATIONS, 1904.

---

UNDER THE DIRECTION OF  
ELWOOD MEAD, Chief.



WASHINGTON:  
GOVERNMENT PRINTING OFFICE,  
1905.

**OFFICE OF EXPERIMENT STATIONS.**

A. C. TRUE, Ph. D., *Director.*

E. W. ALLEN, Ph. D., *Assistant Director.*

**IRRIGATION AND DRAINAGE INVESTIGATIONS.**

ELWOOD MEAD, *Chief.*

R. P. TEELE, *Editorial Assistant.*

C. E. TAIT, *Assistant, in Charge of Central District.*

SAMUEL FORTIER, *Irrigation Engineer, in Charge of Pacific District.*

C. G. ELLIOTT, *Engineer, in Charge of Drainage Investigations.*

YRAGELI INT  
2290000 70

MAR 28 1906  
D. of A.

## LETTER OF TRANSMITTAL.

---

U. S. DEPARTMENT OF AGRICULTURE,  
OFFICE OF EXPERIMENT STATIONS,  
*Washington, D. C., June 30, 1905.*

SIR: I have the honor to transmit herewith the annual report of the work done by the irrigation and drainage investigations of this Office during the season of 1904, under the direction of Elwood Mead, chief. Its publication as a bulletin of this Office is recommended.

Respectfully,

A. C. TRUE,  
*Director.*

Hon. JAMES WILSON,  
*Secretary of Agriculture.*

500.1.627

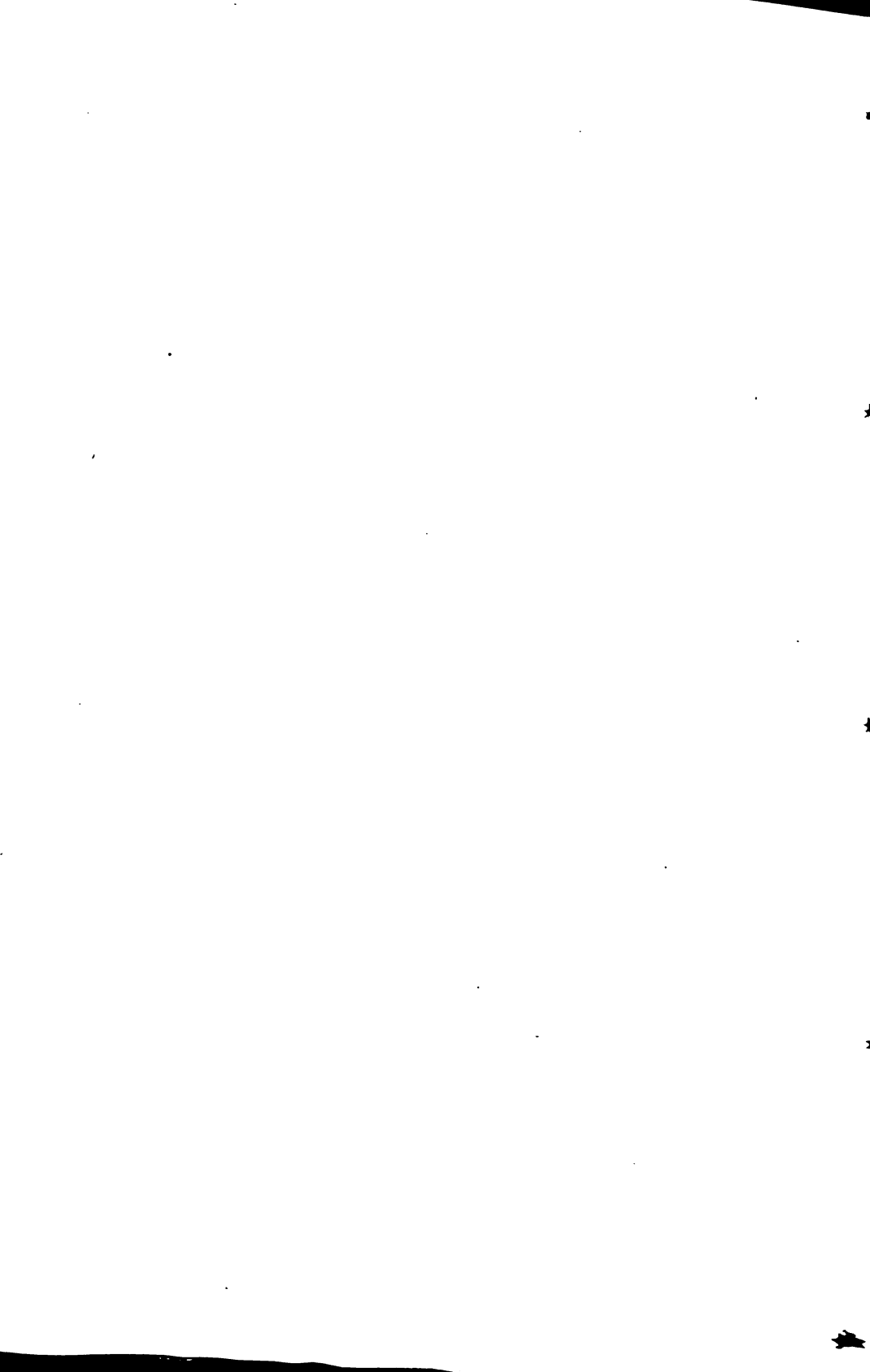

## CONTENTS.

---

	Page.
<b>REVIEW OF THE IRRIGATION WORK OF THE YEAR. By R. P. TEELE.....</b>	<b>19</b>
Leading lines of work .....	21
Duty of water .....	25
Main canals.....	25
Laterals .....	28
Farms .....	30
Crops .....	31
Losses of water from canals .....	35
Return seepage.....	38
South Platte and tributaries .....	38
North Platte and tributaries .....	48
Methods of preparing land for irrigation .....	50
Methods of applying water.....	51
Pumping .....	52
California.....	53
New Mexico .....	54
Texas .....	54
Louisiana .....	56
Arkansas .....	56
Kansas .....	57
Colorado .....	57
Windmills .....	61
Laws and institutions.....	63
Irrigation in the humid sections.....	68
Rice irrigation .....	68
Cranberry irrigation .....	73
Irrigation in Porto Rico.....	75
<b>IRRIGATION IN SANTA CLARA VALLEY, CALIFORNIA. By S. FORTIER.....</b>	<b>77</b>
Introductory.....	77
Sources of water supply.....	78
Orchard irrigation.....	79
The application of water pumped from wells .....	81
Furrow method of irrigation .....	81
Basin method of irrigation .....	82
The duty of water under typical ditches of the Santa Clara Valley.....	82
Statler ditch .....	83
Sorosis and Calkins ditches .....	83
Pioneer ditch .....	84
Loss of water in transit .....	85
Fertilizing value of creek water in Santa Clara Valley.....	85

	Page.
<b>IRRIGATION IN SANTA CLARA VALLEY, CALIFORNIA—Continued.</b>	
The cost and duty of water in 1904 under 60 pumping plants in Santa Clara Valley .....	87
Relation of costs to lift.....	90
Relation of costs to size of plants .....	90
Comparison of the cost of water under ditches and under pumping plants.	90
<b>THE DISTRIBUTION AND USE OF WATER IN MODESTO AND TURLOCK IRRIGATION DISTRICTS, CALIFORNIA. By FRANK ADAMS.....</b>	
Purpose of report and conditions prompting it.....	93
Outline of the investigation .....	95
History of Modesto and Turlock irrigation districts.....	96
Organization .....	96
Opposition to the districts.....	97
Construction.....	98
Litigation .....	100
Water rights.....	102
Modesto and Turlock canals.....	104
Rainfall .....	107
Diversions from Tuolumne River in 1904 by Modesto and Turlock canals.	108
The water used in 1904 .....	111
Quality of water.....	114
Seepage losses.....	115
Crops grown in Modesto and Turlock districts.....	116
Methods of applying water.....	118
Preparing land for check irrigation .....	120
Laying out checks.....	122
Constructing levees and leveling checks.....	123
Distributing laterals .....	125
Setting check boxes .....	126
Cost of checking .....	126
Ground-water records .....	126
The distribution of water .....	129
Conclusion .....	135
Acknowledgments.....	136
Forms for canal records.....	136
<b>RELATION OF IRRIGATION TO YIELD, SIZE, QUALITY, AND COMMERCIAL SUITABILITY OF FRUITS. By E. J. WICKSON.....</b>	
Introduction.....	141
Quantity of product as affected by irrigation.....	142
Regularity of bearing as affected by irrigation.....	148
Qualities and commercial characters of irrigated fruit.....	151
Irrigated fruit in long-distance shipment.....	158
Suitability of irrigated fruits for canning.....	162
Suitability of irrigated fruits for drying .....	165
Irrigated fruits at pomological fairs.....	169
Injuries alleged against irrigation.....	171
<b>IRRIGATION CONDITIONS IN IMPERIAL VALLEY, CALIFORNIA. By J. E. ROADHOUSE.....</b>	
Salton Sink .....	175
Climate.....	177
Natural waterways .....	177
Attempts at reclamation .....	179
Appropriations from the Colorado.....	180
The canal system.....	181

<b>IRRIGATION CONDITIONS IN IMPERIAL VALLEY, CALIFORNIA—Continued.</b>		<b>Page.</b>
<b>Organization</b> .....		181
Water rights .....		182
Imperial Water Company No. 1, a type of mutual water company.....		183
Cost of water rights .....		184
Imperial Water Company No. 4 .....		184
Imperial Water Company No. 8 .....		185
Imperial Water Company No. 6 .....		186
Seepage .....		186
Methods of leveling land.....		189
The scraper.....		189
The leveler .....		190
The planer.....		190
The "A" crowder .....		190
The use of the scraper in making laterals.....		191
The use of water.....		192
Aquatic vegetation.....		193
<b>MECHANICAL TESTS OF PUMPS AND PUMPING PLANTS USED FOR IRRIGATION.</b>		
By J. N. LE CONTE.....		195
Introductory .....		195
Field tests.....		196
Work preparatory to the tests .....		196
Methods pursued .....		196
Description of plants and results of tests.....		198
Plants using gasoline or oil engines .....		199
Plants using electric motors .....		213
Plants using steam engines.....		226
Laboratory tests.....		230
General description of laboratory.....		231
Centrifugal pumps.....		233
Triplex plunger pumps.....		240
Conclusions .....		242
<b>IRRIGATION IN KLAMATH COUNTY, OREG. By F. L. KENT</b> .....		257
Losses from Adams ditches .....		259
Losses from Ankeny ditch .....		260
Losses from Mitchell lateral.....		260
Duty of water .....		261
N. S. Merrill's 38.5-acre tract of alfalfa.....		261
N. S. Merrill's 5-acre tract of alfalfa .....		261
William Ball's 40-acre tract of alfalfa .....		261
William Ball's 95-acre tract of alfalfa .....		262
Ankeny & Cantrell's 118-acre tract of alfalfa.....		262
Ankeny & Cantrell's 110-acre tract of alfalfa.....		262
Evaporation .....		263
Analyses of soil and water.....		264
Soils.....		264
Irrigation water .....		264
Practice in alfalfa growing.....		265
<b>IRRIGATION INVESTIGATIONS IN YAKIMA VALLEY, WASHINGTON, 1904. By O. L. WALLER</b> .....		267
Seepage.....		268
Cost of preparing land for irrigation .....		268
Duty of water.....		273



	Page.
IRRIGATION CONDITIONS IN RAFT RIVER WATER DISTRICT, IDAHO, 1904. By W. F. BARTLETT .....	279
Conditions which govern the control and division of water .....	279
Tributaries to Raft River .....	279
The manner in which the duties of the water master are affected by the nature of water titles and the State irrigation laws .....	281
Provisions for water commissioners and water masters .....	281
Difficulties encountered in installing measuring devices .....	282
Defects of the present law as applying to this district .....	283
Water titles .....	285
Attitude of the irrigators .....	285
Status of the Almo Water Company .....	287
The water supply .....	289
Seepage .....	291
Duty of water .....	292
Interstate questions .....	295
Conclusions .....	299
IRRIGATION INVESTIGATIONS AT NEW MEXICO EXPERIMENT STATION, MESILLA PARK, 1904. By J. J. VERNON .....	303
Duty of water on alfalfa in New Mexico .....	303
Soil .....	304
Equipment .....	304
Labor .....	304
Methods of irrigation .....	305
Cost of irrigating alfalfa with pumped water .....	308
Cost of irrigating wheat with pumped water .....	311
Plan .....	311
Field notes .....	312
Results .....	313
Cost of irrigating corn with pumped water .....	313
Cost of irrigating sweet potatoes with pumped water .....	315
Meteorological conditions .....	316
Temperature of well water .....	316
IRRIGATION INVESTIGATIONS IN WESTERN TEXAS. By HARVEY CULBERTSON .....	319
Introductory .....	319
El Paso .....	321
Trans-Pecos .....	322
Pecos artesian wells .....	323
Pecos Valley irrigation .....	324
Monahans' wells .....	325
Concho, San Saba, and Llano rivers .....	325
Cost of irrigation .....	329
Economical operation of pumps .....	331
Some statements of crop production in Texas .....	333
Methods of irrigation .....	334
Storage of flood waters .....	335
Points in building storage dams .....	337
Size of reservoir .....	337
Land to be irrigated .....	337
Windmill power .....	338
Alkali .....	339
PUMPING PLANTS IN TEXAS. By C. E. TAIT .....	341
Plant owned by W. J. Alderson, near Katy .....	341

PUMPING PLANTS IN TEXAS—Continued.	Page.
Plant owned by John Cope, jr., near Katy .....	342
Plant owned by A. E. Dorn and L. E. Rector, near Katy .....	342
Plant owned by J. C. Rexroat and J. H. Chapman, near Brookshire .....	343
Plant owned by John Gasner, near Brookshire .....	343
Plant owned by W. J. Mettler, near Stilson .....	343
Plant owned by M. B. Sapp, near Stilson .....	344
Plant owned by Hill-Brown Rice Land and Irrigation Company, near Stilson .....	344
Plant owned by D. M. Caffell, near Stowell .....	345
Plants owned by the Texas Land and Irrigating Company, near Stowell..	345
Prices .....	346
<b>IRRIGATION IN SOUTHERN TEXAS. By A. J. BOWIE</b> .....	347
District included in report .....	347
Rainfall in Texas .....	347
Uses of land and acreage .....	349
General topography .....	351
Soil .....	352
Water supply .....	352
Rivers .....	352
Lakes .....	354
Wells .....	354
Artesian districts .....	355
Springs .....	356
Dams .....	357
Method of boring wells .....	357
Strainers .....	358
Cost of boring .....	362
Fuel .....	364
Water conduits in use .....	368
Wooden flumes .....	369
Wooden pipe .....	370
Concrete construction .....	372
General conditions of labor .....	372
Detailed description of irrigation plants .....	373
Cuero .....	373
Victoria .....	377
Creeks .....	382
San Antonio .....	384
San Antonio sewage .....	396
San Antonio River .....	399
Beeville .....	402
Corpus Christi and Alice .....	411
Alice .....	416
South of the Mexican National Railroad .....	416
Kenedy ranch .....	419
Armstrong ranch .....	420
El Sauz ranch .....	421
Lasater ranch .....	422
Rio Grande Valley .....	423
Cienegas Springs .....	427
Eagle Pass .....	427
Laredo and vicinity .....	430
Hidalgo to the coast .....	435

	Page.
IRRIGATION IN SOUTHERN TEXAS—Continued.	
Detailed description of irrigation plants—Continued.	
Nueces, Frio, and Leona rivers .....	444
Nueces River .....	444
Frio River .....	447
Lakes near Carrizo Springs .....	457
Carrizo Springs .....	458
Pearsall .....	469
Altgeld ranch .....	474
Tests of pumps and irrigation plants .....	474
Summary .....	478
Area and crops .....	479
Methods of irrigation .....	479
Duty of water .....	482
Labor and cost of irrigating .....	483
Crop returns .....	483
Onion culture .....	483
Reservoirs .....	484
Artesian wells .....	488
Pumped wells .....	489
Pumping plants .....	490
Pumping .....	493
Method of arriving at cost .....	493
Practical points on increased efficiency of plants .....	500
RICE IRRIGATION IN LOUISIANA AND TEXAS IN 1903 AND 1904. By W. B.	
GREGORY .....	509
The season of 1903 .....	509
The season of 1904 .....	510
Methods of farming .....	514
The waterweed .....	516
Drainage .....	517
Effect of salt water .....	518
The Mermentau dam .....	519
Use of water .....	524
Duty of water at Estherwood, La., in 1903 .....	526
Duty of water at Eagle Lake, Tex., in 1903 .....	527
Duty of water in 1904 .....	529
Duty of water at Estherwood, La., in 1904 .....	530
Duty of water at Crowley, La., in 1904 .....	531
Duty of water at Nottawa, Tex., in 1904 .....	532
Comparison of results of water measurements in rice irrigation for four years .....	533
Evaporation .....	534
Pumping plants .....	534
Pumping plants of the large canals .....	535
Results at two large pumping plants .....	537
The Miller-Morris plant .....	537
The Abbeville plant .....	539
Small pumping plants .....	540
Fuels .....	542
Texas storage dams .....	542
Unpolished rice .....	543
Oil and feed from rice .....	543
Rice straw .....	544

	Page.
<b>RICE IRRIGATION ON THE PRAIRIE LAND OF ARKANSAS.</b> By C. E. TAIT.....	545
Early experiments.....	545
Rice experiment station.....	547
Planting, watering, and harvesting rice.....	555
Other pumping plants used for rice irrigation in Arkansas in 1904.....	559
The Morris plant.....	559
The Fuller plant.....	560
The Boysen plant.....	563
Diversified farming.....	564
<b>IRRIGATION EXPERIMENTS AT FORT HAYS, KANS., 1903 and 1904.</b> By J. G. HANEY.	567
The work of 1903.....	567
Cost of well.....	570
The irrigation field.....	570
Crops, 1903.....	571
Cost of irrigation.....	571
Rainfall and evaporation.....	572
The work of 1904.....	574
Changes in pumping plant.....	575
Winter irrigation.....	576
Summer irrigation.....	577
Cultivation and weather.....	578
Rainfall and evaporation.....	578
Crops and results.....	579
Potatoes.....	581
Other crops.....	582
<b>IRRIGATION NEAR GARDEN CITY, KANS., 1904.</b> By A. E. WRIGHT and A. B. COLLINS.....	585
Introductory.....	585
The apparent supply of underground water.....	586
Windmill irrigation near Garden City.....	589
Cost of windmill plants.....	591
Value of crops irrigated.....	593
<b>PUMPING PLANTS IN COLORADO, NEBRASKA, AND KANSAS.</b> By O. V. P. STOUT..	595
Colorado.....	595
William Kettley, Greeley.....	595
O. Howard and F. W. Steele, Greeley.....	595
Fred Duebach, Greeley.....	596
J. C. Van Aken, Evans.....	596
L. A. Flint, Evans.....	597
P. and C. Huffsmith, Evans.....	597
Percy Clegg, Windsor.....	598
N. E. Gray, Windsor.....	598
Darnell and Fuller, Windsor.....	599
Raymond and Williams, Windsor.....	600
Andrew Wilson, Eaton.....	600
O. J. Blandin, Eaton.....	601
P. A. Jones, Pierce.....	602
S. L. Simpson, Ault.....	602
Nebraska.....	603
J. M. McAleese, Benkelman.....	603
William A. Sharpnack, Alma.....	603
T. H. Smith, Redington.....	604
Bennett Live Stock Company, Kimball.....	604



## ILLUSTRATIONS.

### PLATES.

	Page.
<b>PLATE I.</b> Map of Modesto and Turlock irrigation districts, California.....	94
II. Fig. 1.—A 15-foot concrete drop on Modesto canal. Fig. 2.—Section of Turlock canal, showing concrete lining of lower wall.....	104
III. Fig. 1.—Constructing check levee with scraper. Fig. 2.—Constructing lateral ditch with scraper.....	122
IV. Map of Imperial Valley.....	180
V. Map of southern Texas.....	348
VI. Fig. 1.—Sidehill work on Del Rio canal. Fig. 2.—Reinforced concrete pipe in course of construction, Del Rio canal.....	424
VII. Taylor dam, Nueces River.....	456
VIII. Details of Mermentau dam.....	520
IX. Map of Missouri River Valley, Yankton and Clay counties, S. Dak... ..	660
X. Map of portion of Illinois River Valley, showing Hartwell, Roberts, and Lowenstein levees.....	674
XI. Crevasse in Warsaw-Quincy levee where the embankment has been swept off.....	702
XII. Fig. 1.—Wooden outlet in Hartwell ranch levee. Fig. 2.—Outlet end of outflow culvert in Flint Creek-Iowa River levee, showing wooden valves. Fig. 3.—Outlet end of outflow culvert in Flint Creek-Iowa River levee, showing method of counterbalancing cast-iron valves.....	706

### TEXT FIGURES.

FIG. 1. Diagram showing return seepage to South Platte River.....	42
2. Irrigation by contour check system.....	121
3. Irrigation by rectangular check system.....	122
4. Cross section of levee with wide base.....	124
5. Cross section of excessively high levee with narrow base.....	124
6. Cross section of well-made lateral.....	125
7. Plan of pumping plant owned by Mrs. S. L. Winchester.....	199
8. Plan of pumping plant owned by J. C. Lewis.....	200
9. Plan of pumping plant owned by William Bogen.....	202
10. Plan of pumping plant owned by S. H. Shelley.....	204
11. Plan of pumping plant owned by Darrell & Schumacker.....	208
12. Plan of Hermosa Pumping plant, Portersville, Cal.....	209
13. Plan of pumping plant at Chase Nursery, Corona, Cal.....	211
14. Plan of pumping plant owned by Sunnyside Water Company, Portersville, Cal.....	214
15. Plan of pumping plant owned by Mr. Hall, Lindsay, Cal.....	216

	Page.
Fig. 16. Plan of pumping plant owned by Lindsay Water and Development Company.....	218
17. Plan of Peyton pumping plant belonging to Temescal Water Company.....	222
18. Plan of pumping plant E, belonging to Temescal Water Company ...	223
19. Section of centrifugal pump used in test No. 1.....	232
20. Efficiency curves, test No. 1.....	234
21. Efficiency curves, test No. 2.....	234
22. Efficiency curves, test No. 3.....	236
23. Section of pump used in test No. 4.....	237
24. Efficiency curves, test No. 4.....	238
25. Section of pump used in test No. 5.....	239
26. Efficiency curves, test No. 5.....	240
27. Efficiency curve, triplex pump, test No. 6.....	241
28. Efficiency curve, triplex pump, test No. 7.....	242
29. Millions of gallons of water required to cover a given area to a given depth.....	246
30. Gallons per minute required to supply a given quantity of water in a given time.....	247
31. Brake horsepower necessary to lift given quantities of water.....	248
32. Approximate cost of centrifugal pumps.....	249
33. Approximate cost of small gasoline engines.....	250
34. Approximate cost of large gasoline engines.....	250
35. Approximate cost of induction motors.....	251
36. Cost of fuel per hour with gasoline pumping plants.....	252
37. Electrical energy necessary for operating pumping plants.....	253
38. Cost of power per hour for electric pumping plants at meter rates....	254
39. Cost of power per hour for electric pumping plants at a flat rate of \$50 per horsepower per year.....	255
40. Plan of farm of M. E. Robinson, showing contour levees.....	263
41. Plat of field A.....	303
42. Plat of field B.....	303
43. Plat of wheat field.....	311
44. Chart showing precipitation in Texas.....	319
45. Chart showing evaporation in Texas.....	320
46. Map of trans-Pecos Texas.....	322
47. Map of Concho, San Saba, and Llano rivers.....	325
48. Strainer.....	341
49. Strainer with holes, showing lower part filled with sand.....	359
50. Open-bottom well properly put down.....	360
51. Open-bottom well improperly put down.....	360
52. Strainer covered with copper wire.....	361
53. Strainer covered with copper wire and gauze.....	361
54. Strainer covered with trapezoidal wire.....	362
55. Cost of wooden stave pipe.....	370
56. Cost of wooden stave pipe.....	371
57. Plan of current wheels belonging to Mr. Klein, San Antonio, Tex....	391
58. Section of San Antonio sewage ditch.....	397
59. Map of Corpus Christi Bay.....	413
60. Cross section of reinforced concrete pipe.....	425
61. Bed irrigation.....	434
62. Section of Brownsville canal.....	441
63. Section of Nueces River bed.....	446
64. Plan of Taylor dam, Nueces River, Texas.....	456

	Page.
FIG. 65. Regulating gate for laterals .....	464
66. Furrow irrigation in Texas .....	465
67. Hydrant in use at New Braunfels, Tex. ....	473
68. Plan of rice field at Estherwood, La. ....	526
69. Plan of rice field at Eagle Lake, Tex .....	528
70. Method of making joint between strainer and well casing.....	550
71. Disks for closing bottom of well casing.....	551
72. Section of field levee, Lonoke, Ark .....	554
73. Section of strainer.....	559
74. Jet process of sinking wells .....	561
75. Device for logging out furrows, for two horses.....	611
76. Device for logging out furrows, for one horse.....	611
77. Lath box for distributing water from laterals.....	612
78. Rise of ground water near Fresno, Cal. ....	646
79. Weekly record of fluctuation of ground water levels at Fresno, Cal. ....	647
80. Record of well No. 19, Sunnyside, Wash.....	651
81. Record of well No. 3, Sunnyside, Wash.....	651
82. Map of lower field, St. George, Utah.....	653
83. Profiles across Missouri River Valley, from river to bluff.....	662
84. Section of the old Iowa River levee, built in 1858, now a part of the Flint Creek-Iowa River system.....	667
85. Map of Pekin-Lamarsh levee and drainage district.....	669
86. Map of Lacey levee and drainage district .....	671
87. Lacey district—change in section of levee since first constructed ....	671
88. Map of Coal Creek levee and drainage district.....	673
89. Coal Creek district—section of levee constructed with dipper dredge.....	673
90. Specified section of Sugar Creek levee.....	676
91. Specified section of Brevoort levee.....	676
92. Map of Meredocia levee and drainage district .....	677
93. Map of Muscatine Island levee district .....	679
94. Map showing location of Flint Creek-Iowa River levee.....	681
95. Specified section of enlarged Flint Creek-Iowa River levee.....	681
96. Flint Creek-Iowa River levee—section on firm land which did not fail .....	681
97. Flint Creek-Iowa River levee—section exposed to waves, protected by riprap, has never failed .....	681
98. Flint Creek-Iowa River levee—section where slough occurred on inner slope, afterwards strengthened by banquettes .....	682
99. Flint Creek-Iowa River levee—section at northern part of Ziegler's Slough, sloughed in 1903 .....	682
100. Flint Creek-Iowa River levee—section at Iowa Slough, where sloughing occurred in 1903.....	682
101. Flint Creek-Iowa River levee—section at Campbell Slough, where sloughing was checked in 1903 by sand sacks .....	682
102. Map of Warsaw-Quincy levee .....	683
103. Hunt district levee—section where crevasse occurred .....	683
104. Indian Grave district levee—section where Houghton crevasse occurred.....	683
105. Section across Bear Creek waterway.....	684
106. Map of a part of Sny Island levee and drainage district .....	685
107. Map of a part of Sny Island levee and drainage district .....	686
108. Sny levee—section across old channel known as the "cut-off," pub- lic roadway on the crown.....	687



	Page.
FIG. 109. Sny levee—section near Hannibal, Mo., public roadway on the banquette .....	687
110. Hunt district levee—section of new levee built to close the crevasse	692
111. Proposed section of levee for closing the Houghton crevasse.....	692
112. Section showing plan for improving the original Sny levee.....	693
113. Section showing trace of a muskrat burrow across a levee of small section .....	697
114. Section showing trace of a muskrat burrow across a levee of ample section .....	697
115. Section showing formation of a boil inside of a levee.....	697
116. Map of break No. 1, Indian Grave district.....	701
117. Section across Otter Creek showing dredged channel and spoil-bank levees.....	704
118. Sketch of valve for riveted-plate outflow culvert.....	706
119. Sketch of wooden valve for outflow culvert .....	706
120. Sketch of cast-iron valve for outflow culvert .....	706
121. Method of protecting cultivated hillsides from erosion.....	729
122. Plan of underdrains for Georgia hillside experiment.....	730
123. Ellsworth farm .....	733
124. Lukin farm.....	735
125. Thomas farm .....	736
126. Matthews farm .....	737
127. Phelps farm .....	739
128. George Ehrman farm.....	740
129. Bennett farm .....	741

# ANNUAL REPORT OF IRRIGATION AND DRAINAGE INVESTIGATIONS, 1904.

---

## REVIEW OF THE IRRIGATION WORK OF THE YEAR.

By R. P. TEELE.

In providing for the continuation of the work of the irrigation investigations of the Office of Experiment Stations through the season of 1904, Congress added to the lines of work already carried on the investigation of plans for the "removal of seepage and surplus waters by drainage," and changed the title of the work from "Irrigation investigations" to "Irrigation and drainage investigations." The paragraph of the law providing for this work is as follows:

**IRRIGATION AND DRAINAGE INVESTIGATIONS:** To enable the Secretary of Agriculture to investigate and report upon the laws of the States and Territories as affecting irrigation and the rights of appropriators and riparian proprietors and institutions relating to irrigation and upon the use of irrigation waters at home and abroad, with especial suggestions of the best methods for the utilization of irrigation waters in agriculture, and upon plans for the removal of seepage and surplus waters by drainage, and upon the use of different kinds of power and appliances for irrigation and drainage, and for the preparation, printing, and illustration of reports and bulletins on irrigation and drainage, including employment of labor in the city of Washington or elsewhere; and the agricultural experiment stations are hereby authorized and directed to cooperate with the Secretary of Agriculture in carrying out said investigations in such manner and to such extent as may be warranted by a due regard to the varying conditions and needs and laws of the respective States and Territories as may be mutually agreed upon, and all necessary expenses, sixty-seven thousand five hundred dollars.

As suggested by the law the work is carried on very largely in cooperation with the agricultural experiment stations of the States, thereby securing the use of their equipment and the services of their scientists at an expense much smaller than would be required to do the same work independently of the stations, while the cooperation with this Office enables the stations to enlarge their work on these lines to an extent which would be impossible without the funds supplied by this Office. This cooperation has also brought about a degree of coordination in the work of the various stations which would not otherwise exist. The function of this Office in this work has been to bring about a degree of harmony in the work of the stations and to bring together,

digest, and publish the results of experiments and observations, considered from a standpoint broader than that of any of the individual stations. The cooperative work has in some cases been aided by State appropriations, California providing \$5,000 for the work in 1904, and Nevada providing \$1,000 for the work of the same year. The cooperative work has been carried out as follows:

Prof. S. Fortier, with headquarters at the University of California at Berkeley, has had charge of all work in that State. The university and the State experiment station have aided in the work of this Office by giving a headquarters office free of rent, by aiding in the testing of pumps in the mechanical laboratory, by making free of cost a large number of water analyses, and by aiding in a study of the effects of irrigation on the quality of fruits and vegetables. Professor Fortier was assisted by Prof. J. N. Le Conte and Prof. E. J. Wickson, of the State University, and Mr. Frank Adams and Mr. A. J. Turner, of this Office.

In Nevada we have cooperated with the State experiment station under a special State appropriation, the work being under the direction of Prof. Gordon H. True, of the State station.

In Oregon the field work was carried on under the direction of Director James Withycombe, of the State station, with Prof. F. L. Kent as assistant.

In Washington field work was carried on under the direction of Prof. O. L. Waller, of the State station, with Albert L. Smith as assistant.

In Idaho Mr. W. F. Bartlett, of this Office, was detailed for field work in cooperation with the State engineer's office.

In Utah field work was under the direction of Director J. A. Widtsoe, of the Utah Experiment Station, with Prof. W. W. McLaughlin as assistant.

In Montana field work was carried on under the direction of Director F. B. Linfield, of the State experiment station, with Prof. J. S. Baker as assistant.

In Colorado field work was carried on in part by Mr. A. E. Wright, of this Office, and in part under the direction of Prof. L. G. Carpenter, director of the State experiment station, with Mr. S. L. Boothroyd and Mr. P. J. Preston as field assistants.

In Nebraska field work was under the direction of Prof. O. V. P. Stout, of the State University.

In Kansas field work was carried on at Garden City under the direction of Mr. A. E. Wright and Mr. A. B. Collins, of this Office, and at Hays under the direction of Mr. J. G. Haney, of the State experiment station.

In Louisiana field work was carried on by Prof. W. B. Gregory and Prof. Morton A. Aldrich, of Tulane University.

In New Mexico field work was under the direction of Prof. J. J. Vernon, of the State experiment station.

In Arkansas the work was in part under the direction of Director W. G. Vincenheller, of the State experiment station, and in part done by C. E. Tait, of this Office.

In Indiana field work in drainage was under the direction of Prof. W. D. Pence, of Purdue University, assisted by Mr. K. B. Duncan.

In Iowa field work in drainage and the testing of drainage and pumping machinery was under the direction of Prof. C. J. Zintheo.

In Wisconsin field work was under the direction of Prof. A. R. Whitson; in New Jersey, under the direction of Prof. E. B. Voorhees; in Porto Rico, under the direction of D. W. May, special agent in charge of the experiment station, and in Hawaii, under the direction of Jared G. Smith, special agent in charge of the experiment station.

In addition to the work done in cooperation with the State stations investigations along certain lines have been carried on by the agents of this Office, the irrigation work being under the personal direction of the Chief and the drainage work under the supervision of Mr. C. G. Elliott, drainage engineer.

#### LEADING LINES OF WORK.

The work of this Office in studying the duty of water began with the collection of information as to the quantity of water used in general practice. This included the measurement of water diverted by canals at their head gates, measurements of discharges of laterals at their head gates, and measurements at the margin of fields being irrigated. The farmers were requested to use water according to their usual custom, just as if no measurements were being made. This information was to serve as a basis for a more scientific study of water requirements of crops. Records of these measurements have been published in previous annual reports of this Office.<sup>a</sup>

During the season of 1903 a more scientific study of the water requirements of crops was undertaken. Experiments were begun to determine quantities of water which will produce the largest crop returns under varying conditions. These have been continued through the season of 1904. Such experiments were made in California, Utah, Nevada, and New Mexico. The results of measurements in New Mexico are contained in the report of Professor Vernon, on pages 305-317. A much larger number of measurements have been made in California and Utah, but it was deemed advisable to continue the experiments at least another season before attempting to draw conclusions. Such experiments must necessarily cover a number of years before the results can be considered completed.

---

<sup>a</sup> U. S. Dept. Agr., Office of Experiment Stations Buls. 86, 104, 119, and 133.

In connection with the experiments to determine the water requirements of crops, data regarding the cost of water and lands and the cost of applying the water to crops, and crop returns have been collected in an attempt to work out the principles which should guide farmers in determining how much water to apply to crops. Under certain circumstances it would be to the profit of the farmer to secure something less than the largest crop per acre, if by so doing he could secure crops from a larger area. On the other hand, where the area of land is limited and water is plentiful, it would be to his profit to secure less than the largest product per unit quantity of water, if by increasing the depth of water applied he could secure a sufficiently large increase in the product per acre. Sufficient measurements have not been made, so far, to work out these principles. Experiments are being continued which in time will give the data necessary for such computations. The measurements made by the agents of this Office during 1904 are given in detail in the reports which follow, and those measurements and measurements previously made by this Office and by the State experiment stations and reported in their bulletins are summarized on pages 25-35.

Closely allied with the study of the duty of water is that of methods of applying water to land. It is found that by applying water by one method a given quantity of water can be made to serve larger areas than when it is applied by another method. Methods vary with the character of the soil and with the character of the crops and with the available supply. The experiments of this Office are for the purpose of determining what methods are best suited to various classes of soil which are found throughout the arid region and the different crops which are raised by irrigation, and to varying conditions of water supply. During the year 1904 a bulletin<sup>a</sup> on this subject was published by this Office and the reports given in this volume contain further information on the same subject. This is summarized on pages 51, 52. Great numbers of farmers are beginning irrigation each year and it is probable that with the construction of irrigation works by the Government and by private individuals the number of such beginners will increase very rapidly within the next few years.

The condition of the lands which are to be reclaimed varies widely from that of the humid region from which the settlers will come, and it has therefore been deemed advisable to collect information as to methods of preparing land for irrigation. Bulletin 145 mentioned above contains descriptions of methods of clearing and the implements used, with statements of the cost of such work. Further information is given in the reports which follow, and this is summarized on pages 50, 51. In this work the attempt is made to give directions which can be followed by any farmer of ordinary intelligence, in order that time and money may not be wasted in doing this work by wasteful

---

<sup>a</sup> U. S. Dept. Agr., Office of Experiment Stations Bul. 145.

methods. The preliminary work necessary before crops can be raised by irrigation is much greater than that required in the humid region, since the land must be brought to even slopes, if not leveled, in order that water may be spread over it. This fact is often overlooked by those buying land to be reclaimed by irrigation, and the added expenses for this work have proven very discouraging and often caused failures. In these reports the attempt has been made to state fairly the expenses necessary for preparing land, in order that intending settlers may intelligently weigh the advantages and disadvantages of beginning agriculture in irrigated regions.

It has been found in collecting information as to the duty of water that there is a very wide difference between the quantity of water diverted by canals and that delivered to the land by the same canals. In some places this loss between the head gate and the farm is as great as 90 per cent, and it has been necessary for irrigation engineers to plan works to carry much larger volumes than would be necessary if all or a large part of the water diverted reached the land. In order to give irrigation engineers a basis on which to conclude the additional size of channels necessary, a large number of measurements of the losses from existing canals have been made. These measurements have shown that losses were much greater than was previously supposed, and have called attention to the need and possibility of adopting methods which will check the losses. A series of measurements on a canal will show not only what losses occur but also where these losses occur, and enable the owners to check the losses by improving canals or abandoning especially bad sections. Seepage losses are of importance not only to the owners of the canals from which the water is lost but also to the owners of land lying under canals, since the water lost tends to injure the lands lying below the canals and makes their drainage necessary. The measurements made by this Office since the beginning of the work are summarized on pages 35-38.

While water is lost from canals through seepage, most streams show a gain in flow from this source. Water which leaks from canals and that which is applied to the lands finds its way by gravity back to the streams. The quantity of water which returns to the streams is a very important matter for irrigation officials, modifying and complicating their distribution of water. Measurements show that this return seepage to the streams of the arid region is constantly increasing, making possible a constant increase in the area which may be served by them. The measurements of return seepage are summarized on pages 38-50.

The pumping of water for irrigation is becoming constantly more important. In many regions where the stream supply has been exhausted continuous irrigation has raised the level of the ground water until very often the supply of water for irrigation can be secured

by pumping more cheaply than in any other way, and large areas can be reclaimed for which there is no supply from streams. In parts of California and Colorado pumps are being installed in the midst of regions which are irrigated with river water and increased areas are being reclaimed.

In semiarid regions there are vast areas for which no stream water is available. For these lands the pumping of underground water or the collection of storm water in reservoirs is the only source of supply for irrigation. During the season of 1904 several agents of this Office were detailed to study the operation of existing pumping plants to determine the extent of the water supply, cost of wells, cost of pumping machinery, cost of fuel and of operation, and collect information as to crop returns, to determine not only the possibilities of pumping in semiarid regions, but its profitableness. It is not expected that pumping in these sections for general agriculture will prove profitable, because the lifts are generally high and the cost of fuel is high, but it is believed that it will prove profitable to pump water for vegetables and fruit and some forage, the irrigated areas to be farmed in conjunction with large areas of unirrigated land. The information collected on this subject is summarized on pages 52-63. The detailed reports are found on pages 195-255, 341-507.

The studies of irrigation in the humid sections of the United States carried on in previous years were continued during 1904. These included the irrigation of rice in Louisiana and Texas, the irrigation of rice in Arkansas, and the irrigation of cranberries in Wisconsin and New Jersey. Reports from these various points are contained in the following pages and the results summarized on pages 68-75.

The studies of the laws and institutions controlling the distribution and use of water have been continued during 1904. The work on the Platte River and tributaries, begun in 1903, was completed;<sup>a</sup> the history and present conditions of the Modesto and Turlock irrigation districts in California are reported on (pp. 93-139); the operation of some parts of the irrigation law of Idaho, passed in 1903, was investigated; and information has been collected concerning the laws and institutions of other States. (See pp. 63-68.)

The drainage work of the Office differs from irrigation work in that it consists very largely in giving advice to individuals and associations interested in the reclamation of particular tracts of land. This work is carried on in various localities in all parts of the United States. In the arid region large sections have been ruined by seepage water from canals and irrigated lands and it is necessary to remove this surplus water from the wet lands or intercept it before it reaches them. Throughout the Central States large areas of river-bottom land are annually overflowed, and the drainage engineers of this Office have

---

<sup>a</sup> U. S. Dept. Agr., Office of Experiment Stations Bul. 157.

assisted the owners of these bottom lands in preparing plans for the protection of their lands from overflow and the removal of the surplus water. Along the Atlantic coast studies of the reclamation of salt marshes have been made, and in the South experiments with drainage as a means of reclaiming eroded hillsides and checking erosion have been carried on with very good results. A study of the reclamation of the Everglades of Florida has also been made, and plans for an experiment in draining these lands have been made, but have not yet progressed far enough to give any results. The detailed report of drainage investigations is given on pages 643-743.

**DUTY OF WATER.**

The measurements of the quantities of water used are divided into four classes: Measurements of (1) the quantity of water entering main canals; (2) the quantity of water entering laterals; (3) the quantity of water used on individual farms, and (4) the quantity of water used on separate crops.

**MAIN CANALS.**

The results of the measurements of the first class are of especial use to the builders of irrigation works, whether public or private. They give a fairly definite idea of the quantity of water which must be diverted from a stream to reclaim an acre of ground, and hence are the basis for the computations of the promoter and also for the work of the engineer. For the convenience of those interested in this subject the results of former years have been incorporated in the table with those for 1903 and 1904, which are published for the first time. The following table does not include all of the records of the duty of water under main canals, those for Arizona made by Dwight B. Heard not being received in time to be published in this report:

*Quantity of water used per acre under main canals, 1899-1904.*

[Acre-feet.]

Name of canal.	1899.	1900.	1901.	1902.	1903.	1904.	Average.
<b>Arizona:</b>							
Arizona, Maricopa, and Salt.....		2.45	4.59				3.52
Utah.....		2.49	4.93				3.71
Tempe.....		2.88	4.06				3.47
Consolidated (mesa water).....		2.02	4.53				3.28
Mesa.....	3.81	2.35					3.08
<b>California:</b>							
Gage.....	2.24	2.23	2.00				2.16
Plano.....			7.91				7.91
Poplar.....			3.19				3.19
Pioneer ditch (Tule River).....			8.01				8.01
Pleasant Valley.....			6.31				6.31
<b>Santa Clara Valley</b>						4.93	4.93
Pioneer ditch.....						3.44	3.44
Sorosis and Calkins.....						1.75	1.75
Statler.....						1.58	1.58
Turlock district.....						8.34	8.34
Modesto district.....						13.18	13.18
South Tule Independent.....			7.46				7.46



## Quantity of water used per acre under main canals, 1899-1904—Continued.

Name of canal.	1899.	1900.	1901.	1902.	1903.	1904.	Average.
<b>Colorado:</b>							
Amity .....	4.92						4.92
Grand Valley .....			4.11				4.11
Keefer Extension of Grand Valley .....			5.42				5.42
Lake .....			2.58				2.58
New Cache la Poudre .....					2.21		2.21
Home Supply .....					1.64		1.64
Loveland and Greeley .....					1.96		1.96
Farmers Irrigating .....					1.09		1.09
Supply .....					1.77		1.77
Agricultural .....					.92		.92
Farmers High Line .....					1.41		1.41
Rocky Mountain .....					1.88		1.88
Warrior .....					4.64		4.64
Pioneer Union .....					4.47		4.47
Brantner .....					4.17		4.17
Farmers Independent .....					4.41		4.41
Brighton .....					3.93		3.93
Platteville .....					6.95		6.95
Lower Latham .....					3.26		3.26
Weldon Valley .....					8.23		8.23
Fort Morgan .....					2.14		2.14
Upper Platte and Beaver .....					1.74		1.74
Lower Platte and Beaver .....					1.17		1.17
Tetsel .....					7.35		7.35
Idaho: Raft River, below Langsford's bridge .....						6.00	6.00
<b>Montana:</b>							
Gird Creek .....			1.45	3.50			2.47
Highline .....				5.32			5.32
Kuhen ditch .....				4.68			4.68
Middle Creek .....	2.10	1.90	2.34	1.15			1.87
Big ditch .....		1.88	2.56	3.68			2.71
Republican .....			3.35	4.41			3.88
Hedge .....			3.97	4.76			4.36
Ward .....			2.41	2.49			2.45
Skalkaho .....			4.68	6.79			5.73
Nevada: Orr ditch .....		7.08					7.08
<b>Nebraska:</b>							
Gothenberg .....	2.57						2.57
Mitchell and Gering .....					5.41		5.41
Winters Creek .....					4.78		4.78
Sutherland and Paxton .....					2.03		2.03
North Platte .....					2.17		2.17
New Mexico: Pecos .....	6.61	6.99	10.09				7.90
<b>Utah:</b>							
Butler ditch .....	6.24	5.18					5.71
Brown and Sanford .....	5.32	4.08					4.70
Upper .....	6.30	3.92					5.11
Green ditch .....	4.52	6.14					5.33
Lower .....	2.83	3.06					2.95
Big ditch .....	3.09	2.86					2.98
Logan and Richmond .....	3.59	4.82					4.22
Tanner ditch .....		3.62					3.62
Farr and Harper .....		5.77					5.77
Logan, Hyde Park, and Smithfield .....		3.94					3.94
Bear River .....			4.84				4.84
<b>Washington:</b>							
<b>Natches River—</b>							
Natches and Cowitche .....						4.62	4.62
Natches Valley Irrigation Co. ....						10.50	10.50
New Shannon .....						5.54	5.54
R. S. and C. ditch .....						5.73	5.73
Selah Valley Co. ....						3.33	3.33
Wapato .....						5.71	5.71
Yakima Valley Irrigation Co. ....						4.25	4.25
<b>Yakima River—</b>							
Fowler ditch .....						5.50	5.50
Hubbard and Maxee .....						3.33	3.33
New Reservation .....						10.80	10.80
N. P. Irrigation Co. ....						8.21	8.21
Prosser ditch .....		3.04	4.70			3.98	3.91
Selah and Maxee .....						3.87	3.87
Sunnyside .....	10.64	10.24	9.75	9.11		6.08	9.81
<b>Wyoming:</b>							
Canal No. 2, Wyoming Development Co. ....	2.53	4.90					2.72
<b>Deer Creek—</b>							
Arnold No. 1 .....					14.56		14.56
Mortimore .....					19.16		19.16
Toland Nos. 2, 3, and 4, and Hemingway Nos. 1 and 2 (Little Deer Creek) .....					5.63		5.63
Little Supply, Long, and Heller .....					11.06		11.06
De Voe and Walkinshaw .....					3.84		3.84
Young, Olsen, and Heller .....					10.61		10.61
Seymour and Wells .....					7.92		7.92

Quantity of water used per acre under main canals, 1899-1904—Continued.

Name of canal.	1899.	1900.	1901.	1902.	1903.	1904.	Average.
<b>Wyoming—Continued.</b>							
<b>Horseshoe Creek—</b>							
Macfarlane No. 1 .....					8.70		8.70
Macfarlane No. 2 .....					14.42		14.42
Reeder .....					13.80		13.80
Wain No. 1 .....					11.25		11.25
P. Freaney .....					19.88		19.88
Wain High Water .....					4.51		4.51
St. Dennis .....					9.78		9.78
M. Moran .....					21.13		21.13
T. Freaney No. 1 .....					4.86		4.86
T. Freaney No. 2 .....					12.91		12.91
T. Freaney No. 3 .....					11.62		11.62
D. Gordon .....					5.82		5.82
Moran No. 1 .....					4.89		4.89
Moran No. 2 .....					9.67		9.67
P. J. Hall No. 1 .....					4.58		4.58
W. E. Conalo .....					3.26		3.26
P. Paulsen No. 1 .....					17.74		17.74
Moran and Torgerson .....					13.33		13.33
Torgerson .....					8.61		8.61
Wellman and Dupes .....					5.71		5.71
Dupes and Skolinski .....					8.92		8.92
Walker No. 1 .....					5.59		5.59
Shives .....					6.42		6.42
Howard, Smith, and McDermott .....					10.83		10.83
Walker No. 2 .....					4.52		4.52
Average .....	4.49	4.08	4.80	4.59	7.06	5.75	5.13

This table shows a fairly close agreement for the first four years given. The measurements for 1903 and 1904 were made on different ditches than those for the previous years and the higher averages for these years require explanation.

The figures given for Idaho are hardly comparable with those for the other States, because up to June 19 the measurements were made at a certain point in the Raft River and the duty figured on the basis of the acreage under all the canals below the point of measurement, and no record is given of the flow of the river below the head of the lowest canal. After June 19 the diversions were measured, but no account was taken of the losses and waste from the canals.

The measurements on Deer Creek and Horseshoe Creek, Wyoming, represent a duty based upon the amount of water diverted, but this is above the true duty, because no record is taken of the waste and return flow at the ends of the canals. Certain features of irrigation practice on these two streams make the amount of waste water large. A relatively large area is devoted to the production of native hay, and many of the farmers keep a constant flow of water across their fields, so that something like a third or more of the water returns to the stream without being used. The figures on return seepage on page 50 are very instructive in this connection.

Averaging the figures in the above table gives a depth of 5.13 feet as a general average for all the canals on which measurements have been made. The list includes canals of all ages and all degrees of efficiency. Some of the Utah canals have been in use for nearly half a

century, while the Washington canals have been used for only a few years.

The Gage canal is cemented, so that there is practically no loss of water, while one of the Tule River canals is reported as losing in 2 miles more than 90 per cent of the water entering it. Furthermore, the canals are distributed widely enough to be representative of the whole arid region. The general average of 5.13 acre-feet may therefore be considered a very fair statement of the quantity of water which on the average is being supplied at the head of a canal for each acre of land to be irrigated. Stated in another way: Where a known volume of water can be obtained, the area of land which, according to present practice, can be irrigated with that supply will be 1 acre for every 5.13 acre-feet of water available. As has been stated, this represents present practice, and it should not be considered as representing what is possible. In fact, the possibility of a much more economical use of the water supply is the basis for the hope of a great future expansion of agriculture in many sections where the supply of water is now all in use.

The smallest quantity given in the table is 1.15 acre-feet per acre, under the Middle Creek canal, in Montana, in 1902; the largest is 21.13 acre-feet per acre, under the M. Moran ditch on Horseshoe Creek, Wyoming, in 1903. If the latter locality could get along with as little water as the former, the water used under the M. Moran ditch would serve more than eighteen times the area now farmed. Both of these canals are extremes; but a comparison of the average of all the measurements made in Colorado in 1903, 3.27 acre-feet per acre, with the average of all measurements made in Wyoming in the same year, 8.52 acre-feet per acre, likewise shows a very wide difference in the quantity of water used. These comparisons indicate that a more careful use of the water supply in certain districts would make possible a great expansion of the area devoted to agricultural production.

#### LATERALS.

The following table gives all the measurements at the heads of laterals which have been made by this Office in the four years covered by the investigations.

Quantity of water used per acre under laterals.

Canal.	Lateral.	Year.	State.	Quantity.
				<i>Acre-feet.</i>
Modesto district	Lateral No. 1	1904	California	5.76
Turlock district	Lateral No. 3	1904	do	7.69
Pioneer	Flume lateral No. 2	1901	do	1.41
Amity	Biles lateral	1899	Colorado	1.82
Lake	Lewis lateral	1901	do	3.11
Ridenbaugh	Rust lateral	1899	Idaho	5.06
Do	do	1901	do	6.49
Do	Crawford lateral	1901	do	3.38
Do	Huntington lateral	1901	do	3.04
Do	Cresson lateral	1901	do	4.48
Do	Hunter lateral	1901	do	4.24
Do	Rutledge lateral	1901	do	3.90
Do	Tuttle lateral	1901	do	5.47
Do	Pollard lateral	1901	do	3.81
Do	Clark lateral	1901	do	4.64
Do	Perkins lateral	1901	do	4.49
Do	Brose lateral	1901	do	5.93
Pecos	Division No. 1	1899	New Mexico	6.51
Do	Division No. 2	1899	do	4.53
Do	Division No. 3	1899	do	2.95
Do	Division No. 4	1899	do	3.56
Do	Division No. 1	1900	do	4.65
Do	Division No. 2	1900	do	3.39
Do	Division No. 3	1900	do	2.48
Do	Division No. 4	1900	do	2.27
Do	Division No. 1	1901	do	5.11
Do	Division No. 2	1901	do	3.91
Do	Division No. 3	1901	do	3.02
Do	Division No. 4	1901	do	1.88
Bear River	Lateral A 15	1901	Utah	1.84
Average				4.03

These measurements can hardly be considered as representative, since only eight canals are represented. They show, however, a decrease in the average quantity of water supplied for each acre of a little more than 21 per cent, compared with the average for main canals (see pp. 25-27). If the averages given for the laterals in this table are compared with those for the main canals from which they are taken, the following results are obtained:

Comparison of quantities of water furnished by main canals and laterals therefrom.

[Acre-feet per acre.]

Canal.	Average for canal.	Average for laterals for same.
Pioneer	8.01	1.41
Amity	1.92	1.82
Lake	2.58	3.11
Pecos	7.90	3.69
Bear River	4.84	1.84
Modesto district	13.18	5.76
Turlock district	8.34	7.69
Average	7.11	3.67

Assuming that the laterals given fairly represent all those from the canals named, less than 52 per cent of the water entering these canals reaches the laterals. The figures given for the Lewis lateral are abnormal, since this lateral shows a greater quantity delivered per acre than

does the main canal. There is probably some local cause for this. It is not likely that the others can be considered as representative of canals generally, but they show the conditions on the canals named.

## FARMS.

The measurements of the quantities of water used on individual farms are brought together in the following table:

*Quantity of water used per acre on individual farms.*

State.	Farm.	Crop.	Water used per acre.
Arizona	Vance	Alfalfa and barley	1.98
Do.	Arizona Experiment Station	Mixed	5.70
California	Measured to all consumers under Pioneer ditch.	do	3.19
Do.	Sprott orchard	Oranges and lemons.	1.55
Do.	Selected farms under Pioneer ditch	Fruits	2.00
Do.	Pumped water—average for four years on 25 farms—Lindsay Water Development Co.	do	1.32
Idaho	A. F. Long, 1889	Mixed	2.40
Do.	A. F. Long, 1900	do	3.03
Do.	Edgar Wilson	Orchard	1.48
Do.	C. G. Goodwin, 1900	Mixed	3.25
Do.	C. G. Goodwin, 1901	do	3.32
Do.	N. C. Purcell, 1900	Timothy and alfalfa.	2.43
Nebraska	D. W. Daggett	Mixed	2.47
New Mexico	J. J. Hagerman, 1899	do	15.44
Do.	J. J. Hagerman, 1900	do	9.80
Do.	J. J. Hagerman, 1901	do	12.36
Do.	Average of 70 under Northern canal, N. Mexico	do	2.49
Utah	Cronquist	do	2.59
Washington	Maurice Evans	do	3.58
Do.	Lower Rattlesnake ranch	do	4.60
Do.	Upper Rattlesnake ranch	Alfalfa	3.11
Do.	Jordan orchard	Orchard	6.03
Do.	Dunn hoppyard	Hops	3.43
Do.	R. D. Young	Mixed	10.61
Wyoming	Sigman's ranch	do	3.38
Do.	Webber's ranch	do	1.92
California Gage canal	N. P. Cayley	Oranges	1.98
Do.	J. D. Carscaden	do	1.20
Do.	Gulick Brothers	do	2.38
Do.	C. C. Quinn	do	1.98
Do.	C. E. Kennedy	do	2.48
Average			3.98

Mr. Reed explains that the water used on the Hagerman farm in New Mexico is used largely for ornamentation, and should not, therefore, be included in the averages. Excluding these, the average for farms is 3.07 acre-feet per acre. This is about 69 per cent of the average quantity diverted per acre, showing a loss of 31 per cent between the heads of canals and the place of use, on the assumption that the measurements are representative, showing a possible source for expansion by saving the losses.

These measurements differ so widely, even where conditions are apparently uniform, that they serve to emphasize what has been already mentioned—the possibility of future development by exercising economy in the use of water.

CROPS.

The earlier investigations on this subject were carried on with a view to ascertaining the depth of water applied to the different crops in actual practice. More recently experiments have been undertaken to determine how much water should be used in the production of the various crops in the different parts of the country in order that the water shall be used most economically.

*Quantity of water used in practice.*—A large number of measurements of the depth of water applied to different crops were made during the years 1899, 1900, and 1901. These measurements are given in the following table:

*Depths of water applied to different crops.*

Crop.	Number of measurements.	Depth of water applied.		
		Maximum.	Minimum.	Average.
<b>Alfalfa:</b>				
Idaho .....	4	Feet. 3.93	Feet. 2.04	Feet. 3.12
Montana .....	1			1.90
Nevada .....	1			6.55
Utah .....	2	3.83	3.19	3.51
Washington .....	1			3.11
Total and average .....	9	6.55	1.90	3.99
<b>Barley:</b>				
Arizona .....	1			1.60
Montana .....	6	1.98	.85	1.41
Wyoming .....	1			1.90
Total and average .....	8	1.98	.85	1.49
<b>Corn:</b>				
Arizona .....	1			2.10
Wyoming .....	1			.70
Total and average .....	2	2.10	.70	1.40
<b>Oats:</b>				
Idaho .....	2	4.01	1.84	2.93
Montana .....	11	6.00	.57	1.74
Wyoming .....	2	1.64	1.55	1.60
Utah .....	6	2.70	.45	1.35
Total and average .....	21	6.00	.45	1.73
<b>Orchard:</b>				
Arizona .....	1			1.27
Idaho .....	3	3.06	1.48	2.11
Montana .....	2	1.50	1.48	1.49
Utah .....	1			5.59
Washington .....	1			6.03
Total and average .....	8	6.03	1.27	2.76
<b>Peas:</b>				
Arizona .....	1			2.40
Montana .....	2	1.10	.35	.73
Total and average .....	3	2.40	.35	1.28
<b>Potatoes:</b>				
Arizona .....	4	2.13	2.00	2.10
Nevada .....	2	8.16	7.43	7.80
Wyoming .....	1			3.63
Total and average .....	7	8.16	2.00	3.94

*Depths of water applied to different crops—Continued.*

Crop.	Number of measurements.	Depth of water applied.		
		Maximum.	Minimum.	Average.
<i>Sugar beets:</i>				
Arizona.....	2	<i>Feet.</i> 2.50	<i>Feet.</i> 2.50	<i>Feet.</i> 2.50
Montana.....	1			1.46
Total and average.....	3	2.50	1.46	2.15
<i>Wheat:</i>				
Arizona.....	6	2.50	2.10	2.17
Montana.....	3	2.00	.77	1.18
Nevada.....	2	14.42	8.26	11.34
Utah.....	8	2.26	.63	1.42
Total and average.....	19	14.42	.63	2.68
Hops, Washington.....	1			3.43
New meadow, Idaho.....	1			3.32
Old meadow, Idaho.....	1			2.38
Onions, Arizona.....	1			6.20
Peaches, Arizona.....	1			3.40
Strawberries, Arizona.....	1			6.20
Tomatoes, Arizona.....	1			4.30
Watermelons, Arizona.....	2	3.30	3.20	3.25

These measurements differ as widely as those given in the preceding tables, but the averages show in a general way the relative quantities of water used for the different crops included in the table. These averages, for the crops which are generally raised, are repeated in the following table, which also gives the season during which the crops named require water. The season is found by taking from all the statements on that subject which have been contained in reports to this Office the first and last dates for each crop. Statements referring to Arizona are omitted because irrigation continues throughout the year in that Territory, and its seasons are peculiar to itself.

*Depth of water used for different crops and the irrigating season for each.*

Crop.	Depth of irrigation.	Irrigating season.	Crop.	Depth of irrigation.	Irrigating season.
Potatoes.....	<i>Feet.</i> 3.94	May 17 to Sept. 15.	Sugar beets.....	<i>Feet.</i> 2.15	July 13 to Aug. 17.
Alfalfa.....	3.39	Apr. 1 to Sept. 22.	Oats.....	1.73	May 22 to Aug. 20.
Orchard.....	2.76	Apr. 15 to Sept. 2.	Barley.....	1.49	June 12 to Aug. 1.
Wheat.....	2.68	Apr. 1 to July 26.	Corn.....	1.40	July 24 to July 29.

The average depth given for wheat is undoubtedly too large, on account of the excessive quantities used in Nevada. The season for sugar beets, as given in the table, refers to Montana alone, and is too short for States farther south. It should be extended at least to September 1. Making these allowances, the table shows that in general the most water is used in the production of those crops which have the longest seasons. The statements made in this table are of value as showing what crops can be raised with a given water supply. The grain crops require the least water, and require it at a season of

the year when the streams supply the most. Orchards, potatoes, alfalfa, and sugar beets require water during the season when the flow of streams is at a minimum, and hence only small areas of these crops can be raised without storing water. On the other hand, these crops give much larger returns than the grain crops. The following table gives the average returns per acre for the crops named in the last preceding table:

*Crop returns per acre.*

Potatoes .....	\$75.44
Orchard .....	53.77
Sugar beets .....	42.99
Alfalfa .....	25.36
Barley .....	24.82
Wheat.....	15.95
Corn .....	15.32
Oats.....	15.22

Dividing these into two groups, those requiring water late in the season and those not requiring it then, gives average returns of \$49.39 per acre for the late crops and \$17.83 per acre for the early crops, a difference of \$31.46 per acre in favor of the late crops. Grouping the crops in the same way and reducing the figures given for wheat to agree with those given for oats, the late crops require approximately double the depth of water required by the early crops. Leaving out of consideration the cost of land and the labor required on the different crops, a like quantity of water used on 1 acre of late crops will produce a value of \$49.39 and used on 2 acres of early crops will bring a return of \$35.66, a balance of \$13.73 in favor of using the water for 1 acre of late crops. Against this must be charged the cost of storing the extra water. The portion of water which must be stored will vary with the localities and with the seasons, but 1 acre-foot per acre is certainly a safe estimate. The average cost of reservoirs in the Cache la Poudre Valley, Colorado, as given in a previous bulletin of this Office,<sup>a</sup> is \$5 per acre-foot of capacity. The annual maintenance charges are but a few cents per acre-foot, showing a good profit from the late crops, leaving out of account the extra cost for the double area of land required for the grain crops. The above figures show that it is much more profitable to store a part of the flood waters of the early summer for use on late crops than to extend the area of the early crops to the limit of the water supply. In other words, where the late summer flow of streams is now fully appropriated but there is an unused flood discharge, storing the flood waters will be more profitable than building canals to bring the flood waters to new land.

*Experiments on the duty of water.*—Investigations have been carried on by this Office, in cooperation with several of the agricultural

<sup>a</sup>U. S. Dept. Agr., Office of Experiment Stations Bul. 92.



experiment stations, to ascertain how much water should be applied to a given area of land in the production of a given crop, in order that the best results shall be attained.

The method has been to secure several plats of land which have a uniform soil and to apply water in varying depths to the different plats in the production of a given crop. Such work has been included in the cooperative investigation in California, experiments being carried on at Pomona and Chico. The results have not yet been reported. The cooperative irrigation work with the Utah station consists almost entirely of experiments along this line. The crops included are Italian rye grass, orchard grass, alfalfa, wheat, barley, corn, oats, potatoes, carrots, onions, cabbage, and sugar beets. Plats of each crop are to receive different quantities of water, receive water at different stages of their growth, to have water applied by different methods, and are to be cultivated at different times and with varying degrees of intensity.

In addition to the plat experiments at the agricultural experiment station, arrangements have been made with farmers living in different parts of the State to irrigate and cultivate their crops according to plans made by the agents of this Office, the work being in a general way similar to that at the experiment station, but done under field conditions. Records are kept showing the time each plat or field is watered, the depth of water received, the dates when it is cultivated, the yield per acre, and any other facts which are necessary to make the statement complete. The records for the work of 1904 have been brought together, but one year's work is not considered a sufficient basis for definite conclusions. Therefore these records will not be published until next year. Similar experiments were made in New Mexico in 1904, and the report is given on pages 305-317. The experiments seem to indicate that the product increases more rapidly than the quantity of water applied to a certain point, after which the total product per acre can be increased for a time by further additions of water, but a point is finally reached where the total product per acre decreases as the quantity of water applied is increased. This means, of course, that the maximum product per inch in depth of water applied is reached long before the point of maximum return per acre has been reached. In the production of oats at the Utah station, for example, it was found that the largest product per acre was secured where water was applied to a depth of 30 inches, but the largest product per acre-inch of water was secured when the depth was limited to 15 inches. In the production of wheat at the New Mexico station it was found that the largest product per acre-inch was secured when the depth of water was limited to 24 inches, but that the product per acre continued to increase until 35.3 inches had been applied.

It is very evident, therefore, that where land is plentiful and water is scarce it is poor economy to continue to apply increasing depths of

water until the product per acre has reached the maximum, when the same water could be made to produce a much larger product by applying it to a larger area of land. If more labor were not required per acre-inch of water, where the given amount of water is applied to the larger area of land in the production of a given crop, it would seem that the depth per acre should be so limited that the product per acre-inch of water shall reach the maximum. But as a matter of fact more labor is required when the larger area is used, for there are certain field operations, such as plowing, sowing, and reaping, which cost about so much per acre. It would appear, therefore, that neither the largest product per acre of land nor the largest product per acre-inch of water would prove most profitable to the farmer. The most profitable use of the water lies somewhere between these two extremes. In some localities where water is abundant the economic use of water will lead to the application of a greater quantity per acre than where the water is scarce. It is only by careful experimentation that the farmers of each district will be able to adjust the relations between the quantity of the water and the quantity of land to be watered by a given water supply so as to secure the largest net profit in return for their own exertions.

The relative scarcity of water, as compared with the area of land which could be irrigated were the supply sufficient, gives great importance to the work of this Office along the lines of conserving moisture in the soil, so as to reduce the quantities which must be supplied by irrigation. The high value of irrigated products and the limited water supply in California make this work of especial importance there. Canals have been cemented to avoid seepage losses; water is taken to the fields in underground pipes, and in some sections is distributed over the fields in pipes or hose. This Office is extending a step farther the means of saving water by making experiments to determine what methods of applying water and of cultivation after irrigation will reduce to the lowest point the water requirements of crops and the losses from evaporation. The experiments are still in progress, but some results can be given. Water was applied by three different methods: (1) Flooding the surface; (2) in furrows 3 inches deep; and (3) in furrows 12 inches deep. Taking as a basis the quantity of water evaporated under surface flooding, applying water in furrows 3 inches deep brought about a saving of 13 per cent, while applying it in furrows 12 inches deep brought about a saving of 25 per cent.

#### **LOSSES OF WATER FROM CANALS.**

Since the beginning of this investigation measurements of the losses of water from canals have been made in connection with the studies of duty of water to compare the losses from canals and from irrigated

fields. The details of the measurements on any canal are of value chiefly to the owners of the canal, by showing them the losses which they sustain and where these losses occur, enabling them to determine whether they can afford to make the expenditures necessary to improve their canals. The averages, however, from measurements covering a large number of canals are of general interest, since they indicate something as to the amount of loss which must be reckoned with under average conditions. The following table brings together the measurements made by this Office during the years which the investigation has been conducted:

*Losses from canals from seepage and evaporation.*

Name of canal.	Volume carried (cubic feet per second).	Loss per mile.		Date.
		Cubic feet per second.	Per cent.	
<b>Arizona:</b>				
Arizona.....	79.90	0.70	0.88	June 26, 1900.
Do.....	93.25	.75	.80	Aug. 4, 1900.
Do.....	113.00	.54	.48	Oct. 8, 1900.
Consolidated.....	124.60	.88	.70	May 29, 1900.
Do.....	22.80	.50	2.20	June 26, 1900.
Do.....	53.25	.70	1.31	Aug. 4, 1900.
<b>California:</b>				
Callison slough.....	55.00	.....	5.20	June 6, 1901.
Tipton irrigation district.....	75.50	.....	6.80	May 28, 1901.
Do.....	48.70	.....	6.75	June 17, 1901.
Fine ditch.....	21.20	.....	11.33	May 24, 1901.
Do.....	31.90	.....	16.00	June 18, 1901.
Vandalia ditch.....	16.00	.....	46.00	Do.
Do.....	16.00	.....	44.50	June 21, 1901.
Do.....	10.20	.....	64.00	July 1, 1901.
Porter slough.....	97.60	.....	.80	June 1, 1901.
Do.....	3.70	.....	11.50	July 9, 1901.
Poplar ditch.....	35.30	.....	6.25	June 12, 1901.
Do.....	73.30	.....	3.25	June 14, 1901.
Do.....	73.30	.....	2.84	Do.
Do.....	42.80	.....	9.50	June 27, 1901.
Do.....	26.90	.....	6.55	June 29, 1901.
Do.....	21.90	.....	7.66	Do.
Plano ditch.....	7.50	.....	16.00	July 1, 1901.
Pioneer.....	45.00	.....	2.14	May 20, 1901.
Do.....	37.70	.....	.46	May 31, 1901.
Do.....	27.70	.....	1.45	Do.
Do.....	37.20	.....	2.20	July 10, 1901.
Do.....	23.90	.....	1.09	Do.
Pleasant Valley ditch.....	5.60	.....	11.11	July 2, 1901.
Do.....	4.90	.....	8.60	Aug. 1, 1901.
South Tule ditch.....	7.90	.....	2.80	July 3, 1901.
Do.....	5.60	.....	2.50	Aug. 4, 1901.
Ditches in Santa Clara Valley.....	.....	.....	6.00	1904.
<b>Imperial—</b>				
Birch lateral.....	17.75	.25	1.40	1904.
Do.....	24.45	.20	.80	1904.
Beach lateral.....	7.12	.42	5.90	1904.
Dahlia.....	45.40	.94	2.07	1904.
Dogwood lateral.....	22.60	.95	4.22	1904.
Holt lateral—	.....	.....	.....	.....
First section.....	27.28	.57	2.00	1904.
Second section.....	12.92	.31	2.40	1904.
Rose lateral—	.....	.....	.....	.....
First section.....	36.55	.75	2.07	1904.
Second section.....	24.54	.26	1.05	1904.
Modesto.....	260.00	1.70	.65	1904.
<b>Colorado:</b>				
Grand Valley, high line a.....	139.62	.53	.38	July 10-12, 1901.
Lake.....	456.33	2.23	.49	June 9, 1901.
<b>Idaho, Raft River: Pierce-Keogh west ditch.....</b>				
	4.76	.41	8.61	1904.

a Main line of Grand Valley canal shows a gain.

*Losses from canals from seepage and evaporation—Continued.*

Name of canal.	Volume carried (cubic feet per second).	Loss per mile.		Date.
		Cubic feet per second.	Per cent.	
<b>Montana:</b>				
Middle Creek .....	98.90	5.38	5.34	July 10, 1899.
West Gallatin .....	114.45	.96	.86	July 18-20, 1900.
Farmers' .....	133.10	2.19	1.65	July 30, 1900.
Middle Creek .....	63.04	1.16	1.84	June 27-28, 1900.
Big ditch .....	254.47	2.96	1.16	Aug. 9-13, 1900.
Republican .....	120.49	3.05	2.53	July 21-24, 1900.
Nebraska: Culbertson .....	80.62	1.94	2.41	Aug. 7-8, 1894.
<b>Oregon, Klamath County:</b>				
<b>Adams ditches—</b>				
New ditch .....	16.99	.29	1.71	1904.
Old ditch .....	18.16	.29	1.60	1904.
Ankeny ditch .....	43.98	.86	1.96	1904.
Do .....	43.41	1.21	2.79	1904.
Mitchell ditch .....	3.93	.53	13.62	1904.
<b>Utah:</b>				
Logan and Richmond .....	82.10	.....	2.28	Average of 6.
Logan, Hyde Park, and Smithfield .....	50.57	.....	2.65	Average of 8.
Bear River .....	279.34	4.02	1.44	June 25, 1901.
West line .....	138.59	.42	.30	June 25-26, 1901.
Corinne line .....	118.94	.82	.69	June 26-27, 1901.
West line .....	319.27	3.54	1.11	Aug. 6-8, 1900.
<b>Washington, Yakima Valley:</b>				
Snipes lateral .....	63.00	.84	1.33	1904.
South Branch lateral .....	16.51	.13	.80	1904.
<b>Wyoming:</b>				
Canal No. 2 .....	89.65	.....	1.00	July 9-11, 1900.
Do .....	36.52	.....	.94	Aug. 20-22, 1900.
<b>Average</b> .....	.....	.....	6.76	.....

<sup>a</sup> Includes what is given as main line in measurement of 1901.

The general average of all these measurements shows that 6.76 per cent of the water entering the canals is lost in each mile of length, the losses ranging from 0.3 to 64 per cent per mile. The heavier losses occur in the small ditches flowing over gravel-bottom lands, while the small losses occur in ditches which are so situated that they presumably receive drainage from higher lands and those which carry muddy water through a fine soil and therefore become silted.

Grouping the canals given in the foregoing table according to the volume of water carried gives the following results:

*Losses of water from canals by seepage and evaporation, by groups.*

	No.	Percentage of loss per mile.
Canals carrying 100 cubic feet per second or more .....	13	0.95
Canals carrying between 50 and 100 cubic feet per second .....	15	2.58
Canals carrying between 25 and 50 cubic feet per second .....	15	4.21
Canals carrying less than 25 cubic feet per second .....	24	11.28

This table brings out very clearly the advantage of carrying water in large canals rather than in several small canals, where this can be done. Along a great many streams several canals parallel one

another for long distances. In such situations the carrying of the water in one large canal would mean a very great saving of water.

The figures given in the foregoing tables are the results of a single series of measurements in each case and are, therefore, liable to considerable error, due to changes in the discharge of the canal during the progress of the measurements or to conditions which are temporary. A much better measurement of the losses would be continuous records of the flow at the upper and lower ends of the sections under consideration. Such records were kept during the season of 1904 on the Modesto and Turlock canals in California (see p. 116).

The records for the season are given in the following table:

*Losses of water from Modesto and Turlock canals during the season of 1904.*

Modesto canal:

Discharge for season at head.....acre-feet..	90,795
Discharge for season at Waterford, 22 miles below head, acre-feet.....	76,717
Loss.....acre-feet..	14,078
Percentage of loss.....	15.51
Percentage of loss per mile.....	.71

Turlock canal:

Discharge at head, for season.....acre-feet..	166,845
Discharge 22 miles below head.....do....	136,753
Loss.....do....	30,092
Percentage of loss.....	18.04
Percentage of loss per mile.....	.82

The single measurement of the Modesto canal previously given showed a loss of 0.65 per cent per mile, while the record for the season showed a loss of 0.71 per cent per mile, a very slight variation.

### RETURN SEEPAGE.

#### SOUTH PLATTE AND TRIBUTARIES.

The gain in the flow of streams, due to return seepage from the irrigated lands lying along their courses, has been brought into great prominence during the past few years in connection with discussions of the use of interstate streams in irrigation. These, however, are equally important on other streams, affecting the distribution of water by public officials. In order that these officials may make a fair division of the water, it is necessary that they know approximately how much water will return to the stream along its course to supply ditches heading on the lower sections. Measurements of return seepage have been carried on on the South Platte and its tributaries in Colorado for many years. The records on the Cache la Poudre extend back to 1885,<sup>a</sup> and on the South Platte to 1889.<sup>b</sup>

<sup>a</sup>Colorado Station Bul. 33.

<sup>b</sup>Reports of the State engineers of Colorado.

During the season of 1903, in connection with the study of rights to water from the Platte River and its tributaries in Colorado, Wyoming, and Nebraska, measurements were made to determine the amount of return seepage on the South Platte River in Colorado and Nebraska, on the St. Vrain in Colorado, on the North Platte in Wyoming and Nebraska, and on the Laramie in Wyoming. These measurements are partially reported in Bulletin 147 of this Office, but are given here more in detail. The following table shows the gains in the flow of the South Platte River as measured in August, 1903, by Mr. C. E. Tait, of this Office, and Prof. O. V. P. Stout, of the University of Nebraska:

*Return seepage to South Platte River, August 3-20, 1903.*

[Cubic feet per second.]

Section measured.	Length of section.	Discharge at upper station.	Inflow.	Diver-sions.	Dis-charge at lower station.	Gain (+) or loss (-) in section.	Gain (+) or loss (-) per mile.
	<i>Miles.</i>						
Platte Canyon to City ditch.....	5.25	91.85	.....	114.80	8.69	+ 31.64	+ 6.04
City ditch to Littleton.....	6.25	6.04	3.06	14.04	19.37	+ 24.31	+ 3.89
Littleton to Denver.....	10.50	35.52	3.97	5.69	46.36	+ 12.56	+ 1.19
Denver to below Clear Creek.....	7.00	59.18	53.66	16.34	122.66	+ 26.16	+ 3.74
Below Clear Creek to below Brantner ditch.....	7.00	122.66	.74	156.58	9.20	+ 42.38	+ 6.05
Below Brantner ditch to Brighton.....	7.25	4.75	.00	13.00	26.81	+ 35.06	+ 4.84
Brighton to Fort Lupton.....	7.50	26.81	3.86	44.33	5.09	+ 18.75	+ 2.50
Fort Lupton to Platteville.....	8.50	9.99	.00	33.69	1.97	+ 25.67	+ 3.02
Platteville to above St. Vrain River.....	4.75	1.97	.00	11.47	13.84	+ 23.34	+ 4.91
Above St. Vrain River to above Section 3 ditch.....	7.25	13.84	96.74	90.99	58.13	+ 38.54	+ 5.32
Above Section 3 ditch to below Big Thompson River.....	2.50	58.13	33.09	31.22	68.87	+ 8.87	+ 3.55
Below Big Thompson River to Evans.....	2.50	68.87	9.17	86.12	6.73	+ 14.81	+ 5.92
Evans to below Cache la Poudre River.....	6.50	6.73	34.22	33.33	61.15	+ 53.53	+ 8.24
Below Cache la Poudre to Kersey.....	2.00	61.15	.00	.00	93.31	+ 32.16	+ 16.08
Kersey to above Bijou canal.....	11.00	93.31	1.34	10.18	116.99	+ 32.52	+ 2.96
Above Bijou canal to below Putnam ditch.....	8.00	116.99	.00	20.56	117.99	+ 21.56	+ 2.69
Below Putnam ditch to above Fort Morgan canal.....	16.50	117.99	.00	142.41	32.25	+ 56.67	+ 3.43
Below Fort Morgan canal to below Bijou Creek.....	8.00	32.25	2.54	.00	60.76	+ 25.97	+ 3.25
Below Bijou Creek to Fort Morgan.....	3.00	60.76	.00	1.00	62.39	+ 2.63	+ .88
Fort Morgan to Snyder.....	11.50	101.36	.00	1.33	146.27	+ 46.24	+ 4.02
Snyder to Merino.....	18.00	146.27	.00	151.93	29.10	+ 34.76	+ 1.93
Merino to Sterling.....	14.50	29.10	.85	81.20	22.67	+ 73.92	+ 5.09
Sterling to Hiff.....	10.00	22.67	16.49	64.20	14.23	+ 39.27	+ 3.92
Hiff to Crook.....	15.00	14.23	.00	13.48	5.36	+ 4.61	+ .31
Crook to Sedgwick.....	17.00	5.36	.00	1.29	5.78	+ 1.71	+ .10
Sedgwick to Julesburg.....	13.50	6.78	.00	.00	7.75	+ 1.97	+ .13
<b>Total for Colorado.....</b>	<b>232.75</b>					<b>+727.61</b>	<b>+ 3.30</b>
Head of Western canal to Ogalalla.....	26.50	91.10	.00	11.25	4.99	- 74.86	- 2.82
Ogalalla to Korty.....	13.00	4.99	2.72	.00	.00	- 7.71	- .59
<b>Total for Nebraska.....</b>	<b>39.50</b>					<b>82.57</b>	<b>- 2.09</b>

The last column of the table showing the gain or loss per mile is valuable for the purpose of comparing the gains in different sections of the stream. The largest return—16.08 cubic feet per second per mile—is in the section immediately below the mouth of the Cache la Poudre, the largest tributary of the South Platte. The canals heading in the Cache la Poudre, as well as those heading in the Platte, irri-

gate large areas bordering this section of the stream, and seepage water finding its way down the valley of the Cache la Poudre also enters this section of the river. The next largest gain—8.24 cubic feet per second per mile—is in the section immediately above that showing the largest gain. This section lies just below the mouth of the Big Thompson River, and a large part of this gain undoubtedly comes from land watered by the Big Thompson. Similarly, the next largest gain is in the section just below the mouth of Clear Creek. The other sections showing the large gains are also near the mouths of natural tributaries whose valleys are irrigated. The lowest rate of gain is in the sections farthest down the river, where there is little irrigation and no tributaries. In the two sections in Nebraska, where there is even less irrigation than in Colorado, the channel becomes more sandy and broader. The river was entirely dry at Korty when these measurements were made.

Measurements similar to those reported on page 39 have been reported by the State engineers of Colorado covering the years from 1889 to 1902, with the exception of 1897. The results of these measurements are given in the following table:

*Gain in flow of South Platte River from return seepage.*

[Cubic feet per second.]

Section.	Distance.	1889.	1890.	1891.	1892.	1893.	1894.	1895.
	<i>Miles.</i>							
Platte Canyon to head of City ditch.	5.25			27.57	25.32	18.41	49.23	20.21
Head of City ditch to Littleton	6.25	49.91	11.73	52.61	44.63	23.50	25.59	56.23
Littleton to Denver	10.50	1.00	43.88	16.20	59.61	41.27	118.92	117.80
Denver to Brighton	21.25	26.16	43.30	78.81	-13.39	69.73	84.30	13.89
Brighton to Platteville	16.00	56.31	78.00	51.74	64.37	65.91	65.01	134.44
Platteville to Evans	17.00	63.62	78.00	72.28	12.82	61.11	107.46	44.28
Evans to Putnam ditch	27.50		156.69	119.50	137.75	85.85	98.61	179.41
Putnam ditch to Fort Morgan	27.50	188.58	50.58	51.80		113.89	158.52	284.11
Fort Morgan to Snyder	11.50							14.82
Snyder to Merino	18.00		21.53	79.73		34.72	58.67	145.26
Merino to Sterling	14.50	32.75	29.45	33.36		33.76		46.80
Sterling to Iliff	10.00	4.44	14.05	28.07		24.84	43.80	16.99
Iliff to Crook	15.00			-13.07				-48.05
Crook to Sedgwick	17.00			3.31			-34.17	-32.89
Sedgwick to State line	15.50							
Total	232.75	422.77	449.21	602.00	330.61	572.99	722.56	942.30

Section.	Distance.	1896.	1898.	1899.	1900.	1901.	1902.	1903.
	<i>Miles.</i>							
Platte Canyon to head of City ditch.	5.25	10.18	1.21	72.93	33.96	21.22	5.04	31.64
Head of City ditch to Littleton	6.25	14.76	26.44	60.96	40.17	11.49	13.24	24.31
Littleton to Denver	10.50	33.95	61.63	16.40	16.22	35.63	24.90	12.56
Denver to Brighton	21.25	67.29	49.66	124.01	70.27	73.29	48.67	103.60
Brighton to Platteville	16.00	92.87	112.35	88.79	56.08	130.67	66.24	44.42
Platteville to Evans	17.00	37.59	110.97	111.50	117.10	138.84	95.17	85.56
Evans to Putnam ditch	27.50	87.99	160.13	150.38	79.14	182.24	92.23	139.77
Putnam ditch to Fort Morgan	27.50	90.61	94.62	97.74	99.79	90.89	117.28	85.27
Fort Morgan to Snyder	11.50	52.79	37.13	72.63	83.77	65.87	61.33	46.24
Snyder to Merino	18.00	66.21		93.87	85.54	97.04	80.35	34.76
Merino to Sterling	14.50	32.60		73.73	62.03	47.00	97.17	73.92
Sterling to Iliff	10.00	21.36		46.19	5.19	32.04	7.27	39.27
Iliff to Crook	15.00			69.38	23.64	12.12	29.83	4.61
Crook to Sedgwick	17.00			-17.13	-50.69		.10	1.71
Sedgwick to State line	15.50			41.23	77.98	3.73	10.67	1.97
Total	232.75	608.20	654.14	1,102.61	800.19	941.57	749.49	729.61

The table shows that there is no uniformity in the gain in any section from year to year or in the stream as a whole. The amount of return seepage depends on so many factors which vary from year to year that it is not to be expected that there would be any uniformity or any gradual increase or decrease in the seepage returns in any given section. The amount of water coming into the stream from the lands bordering it in any section must depend primarily upon the amount of water received by these lands, either in the form of rainfall or irrigation. The amount of rainfall varies from year to year without any fixed law, and the amount used in irrigation depends upon the amount which can be secured for that purpose. In general, then, larger returns will be expected in wet years than in dry years, since in such years the lands receive more water from both irrigation and rainfall.

The rate of flow of water through soils is extremely slow, and water applied to land at some distance from the stream takes several years to reach the stream, so that the entire effect of heavy irrigation may not be shown immediately in the return seepage. This would tend to decrease the variations in the return flow due to wet and dry seasons. It is therefore practically impossible to establish any relation between the quantity of water received by land and the amount of water which will be supplied by this land to the stream. However, grouping these measurements will help to minimize the effect of variations since these will tend to offset each other. The measurements given cover fourteen years. Dividing these into two seven-year periods gives the results which are shown in the following table:

*Gain or loss in flow of South Platte River by seven-year periods.*

[Second-feet.]

Section.	Length.	Before 1896.		After 1895.	
		Total.	Per mile.	Total.	Per mile.
	<i>Miles.</i>				
Platte Canyon to City ditch.....	5.25	28.15	5.36	25.17	4.79
City ditch to Littleton.....	6.25	37.17	5.95	27.84	4.36
Littleton to Denver.....	10.50	56.95	5.42	28.76	2.74
Denver to Brighton.....	21.25	43.26	2.04	76.68	3.61
Brighton to Platteville.....	16.00	67.94	4.25	84.49	5.28
Platteville to Evans.....	17.00	57.32	3.37	99.53	5.85
Evans to Putnam ditch.....	27.50	119.90	4.86	127.41	4.63
Putnam ditch to Fort Morgan.....	27.50	93.34	3.39	95.17	3.46
Fort Morgan to Snyder.....	11.50	25.12	2.18	59.97	5.21
Snyder to Merino.....	18.00	63.35	3.52	76.30	4.24
Merino to Sterling.....	14.50	32.03	2.21	64.41	4.44
Sterling to Iliff.....	10.00	16.58	1.66	25.22	2.52
Iliff to Crook.....	15.00	-14.83	-.99	27.92	1.86
Crook to State line.....	32.50	-21.25	-.65	13.91	.43

In some years the sections between measurements were not the same as those given in the table, but included two or more of the sections as given. In such cases the gain or loss in the larger section is divided between the sections as they are given in the table in proportion to the mileage. The results given in the table are shown graph-



ically in figure 1. In the figure the vertical scale represents gain in cubic feet per second per mile, and the horizontal scale represents

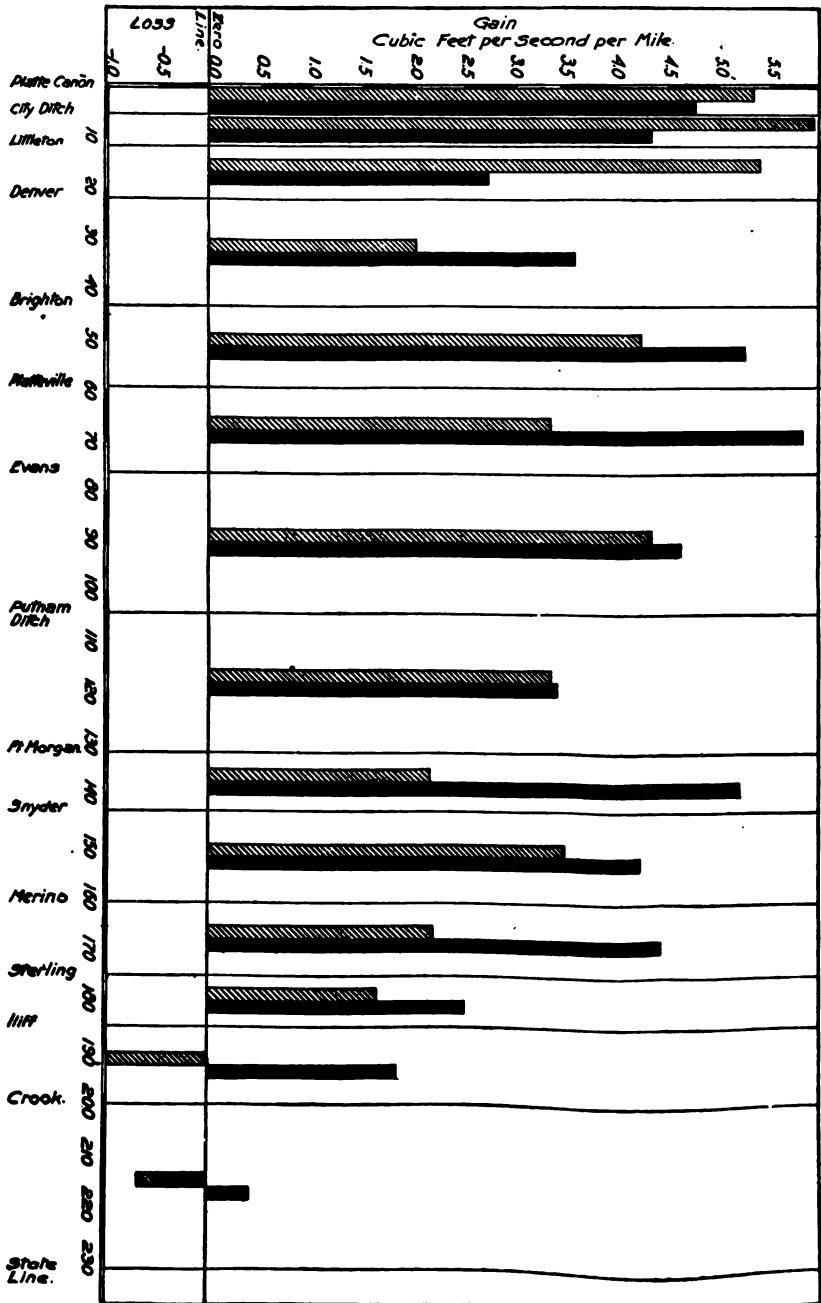

FIG. 1.—Diagram showing return seepage to South Platte River for two seven-year periods, 1889-1895, and 1896-1903, excluding 1897.

distance from the upper measurements at Platte Canyon. The hatched columns show the gains in the first seven-year period, from 1889 to 1895. The solid columns show the gains in the second seven-year period, from 1896 to 1903, excluding 1897. The difference in the heights of the two columns for any section represents the increase or decrease in the return waters for that section in the second seven-year period over the return waters for the same section for the first seven-year period. The diagram shows that between Platte Canyon and Denver the return seepage was greater for the first seven-year period than for the second.

Few diagrams connected with irrigation investigations are more instructive than figure 1. The variation in the return seepage in the different sections of the river reflects with surprising accuracy the influences which modified return seepage during that time. Beginning at the upper end and taking the section embraced in the 20 miles from Platte Canyon to Denver, we find that the return seepage during the first period was greater than during the second period, a decrease instead of an increase in the quantity of water returning. This is contrary to the general tendency on western streams, and there must have been some special reason. What was it? There were two predominating causes. During the greater part of the first period there was no law requiring protection of priorities and requiring the division of water between irrigation districts. The Platte River was divided into three districts, and the section between Platte Canyon and Denver was in the upper district, and the two lower districts had no legal means of compelling the irrigators in this section to respect their priorities; hence those in district 3 were, during much of the year, able to have an abundance of water and to use it generously. The result was a large proportion returned as seepage.

Furthermore, in the earlier period the ditches irrigated the lands nearer the streams. Much of this land was underlaid with gravel, and a large percentage of the water taken out returned quickly to the stream. During the second period the law providing for recognition of prior rights on the lower part of the stream was enforced. The quantity of water available in this section of the stream was greatly reduced. Water had to be used with greater economy. The result was a less volume of return seepage. Another contributing cause was that the earlier ditches were extended, reaching farther back from the stream and causing the seepage water to return lower down, probably in some cases below Denver.

In the section between Denver and Evans we find a reversal of what took place in the section between Platte Canyon and Denver. In the upper section the return seepage was less in the second period. In the lower section the return is far greater in the second period. The following are the reasons for this. During the first period the lands

under some of the large ditches were not fully brought under irrigation; hence the subsoil was not fully saturated and the amount of water finding its way back into the stream was small. During the second period the extension of the irrigated area and the filling up of the subsoil had progressed far enough to materially increase the return seepage rate.

Another factor in increasing the seepage flow was the law providing for the recognition of prior rights in the middle district of the stream. This gave more water to this section, and the use of this water produced more return seepage. Still another factor was the construction of reservoirs. The building of the reservoir above Greeley filled the subsoil of that town with seepage water and compelled the building of a drain. This was all seepage water. Undoubtedly a great deal of it passed on beyond the town of Greeley and found its way into the channels of the Big Thompson and Platte, and the same action took place from other reservoirs built during the latter part of the first period and the first part of the second period.

The sections between Evans and Fort Morgan show approximately equal gains in the two periods. In these sections a large number of ditches have been constructed for the purpose of collecting seepage water for use in irrigation. This prevents this water from reaching the river, and therefore it does not show in the measurements of return seepage. This probably explains the fact that the volume of water returned to the stream in these sections did not increase in the second period as compared with the first.

When we come to the lower section of the stream, from Fort Morgan to the State line, we find again a marked increase in the seepage rate during the second period. This grows out of the fact that much of the land was not irrigated until during the first period. The extension of the Fort Morgan and Platte and Beaver ditches, which took place during the first period, did not result in completely saturating the subsoil and bringing about the full effect of return seepage until in the second period. In the district below Sterling there was so little irrigation during the first period that return seepage was not sufficient to overcome losses from evaporation, and we have there a loss instead of a gain. The strengthening of the river's flow by the increased seepage in the section above has, however, made it possible to greatly extend irrigation in the region around Sterling, and the reduction in the flow of the stream due to evaporation has been changed into an increase in flow by the augmented return seepage water during the second period.

The following table gives the results of measurements made on St. Vrain Creek in the fall of 1903 and also those previously made by the State engineers of Colorado.

## Return seepage to St. Vrain Creek, Colorado, 1903.

(Cubic feet per second.)

Section measured.	Length of section.	Discharge at upper station.	Inflow.	Diver-sions.	Discharge at lower station.	Gain (+) or loss (-).	Gain (+) or loss (-) per mile.
	<i>Miles.</i>						
Lyons to below Smead ditch .....	2.25	66.56	0.00	33.77	33.59	+ 0.80	+ 0.36
Below Smead ditch to below Oligarchy ditch .....	2.50	31.84	.00	16.68	23.41	+ 8.25	+ 3.30
Below Oligarchy ditch to below Niwot ditch .....	2.75	23.41	.00	18.24	4.41	-- .76	-- .28
Below Niwot ditch to above Left Hand Creek .....	4.75	4.41	8.67	10.58	14.87	+12.37	+ 2.60
Above Left Hand Creek to county line .....	1.75	17.40	6.25	.00	25.39	+ 1.74	+ .99
County line to above Boulder Creek .....	2.50	25.39	3.60	.00	40.60	+11.61	+4.64
Above Boulder Creek to bridge .....	6.75	40.60	.91	8.68	46.97	+ 5.46	+ .81
Bridge to mouth of creek .....	6.50	38.29	.00	.00	42.00	+ 3.71	+ .57
<b>Total .....</b>	<b>29.75</b>					<b>+43.18</b>	<b>+1.45</b>
<b>Whole stream:</b>							
October 17-19, 1900 .....	29.75	66.24				+ 36.41	+1.22
July and August, 1900 .....	29.75					+28.74	+ .97
August, 1902 .....	29.75					+13.38	+ .45

The measurements show a gain throughout the course of the stream with the exception of one short section.

In the following table are brought together the measurements of return seepage to the other tributaries of the South Platte, as reported by the State engineer of Colorado and the Colorado Experiment Station. The measurements for the Cache la Poudre from 1885 to 1895 are taken from Bulletin 33 of the Colorado Experiment Station. All the other measurements are from the reports of the State engineers.

## Return seepage to the other tributaries of the South Platte.

(Cubic feet per second.)

Stream and date.	Dis- tance.	Flow at upper station	Inflow from tributa- ries.	Diver- sions.	Out- flow at lower station.	Gain.
	<i>Miles.</i>					
<b>Cache la Poudre:</b>						
October 12-15, 1885 .....	35.00	127.61		61.40	153.17	86.96
October 14-17, 1889 .....	38.60	68.72		157.80	9.89	98.97
October 16-18, 1890 .....	38.60	80.78		148.85	32.73	100.80
October 29-30, 1891 .....	38.60	97.68	5.88	122.27	60.72	79.53
March 11-12, 1892 .....	34.85	65.02	1.65	21.29	141.49	96.11
October 5-8, 1892 .....	38.60	62.92		139.28	31.69	108.05
November 9-11, 1893 .....	38.60	52.47		90.39	60.76	98.68
March 13-15, 1894 .....	38.10	99.21		104.60	76.93	82.32
August 20-23, 1894 .....	38.10	268.07	10.33	316.65	82.90	71.15
October 9-14, 1895 .....	38.10	66.47	4.69	72.12	116.84	117.80
1901 .....	38.10	331.22				167.30
1902 .....	38.10	304.00				119.43
<b>Big Thompson:</b>						
1897 .....						64.08
1898 .....						52.74
July 18-21, 1900 .....						51.85
September 8-18, 1900 .....						27.07
September and July, 1901 .....						53.65
July, 1902 .....						42.09

*Return seepage to the other tributaries of the South Platte—Continued.*

Stream and date.	Dis- tance.	Flow at upper station.	Inflow from tributa- ries.	Diver- sions.	Out- flow at lower station.	Gain.
<b>Little Thompson:</b>	<i>Miles.</i>					
1897 .....						10. 63
1898 .....						8. 89
September 15-16, 1900 .....						22. 82
July, 1901 .....						28. 24
August, 1902 .....						14. 73
<b>Boulder Creek:</b>						
1900 .....		29. 25				27. 60
August and September, 1901 .....		59. 68				16. 19
September, 1902 .....		18. 29				12. 48
South Boulder Creek: 1900 .....		9. 24				1. 05
<b>Clear Creek:</b>						
October 29 to November 17, 1900 .....		27. 39				15. 80
September, 1901 .....		144. 27				24. 24
September, 1902 .....		72. 42				8. 78
<b>Bear Creek:</b>						
October 27, 1900 .....		24. 06				15. 71
September, 1901 .....		17. 22				18. 70
September, 1902 .....		. 55				4. 15

All of these streams are extensively used for irrigation and all show substantial gains from seepage. The valleys of all these streams open into the South Platte Valley, and undoubtedly a large part of the return seepage enters the South Platte rather than the stream from which the water was diverted. The volume of return seepage from the lands watered by these streams is, therefore, larger than the figures given in the table indicate.

The results given above are secured by making series of measurements. During the season of 1903 an attempt was made to keep a complete record of the diversions from the South Platte and its tributaries. Records were kept by the water commissioners in cooperation with the agents of this Office. These records are more or less complete, and in only a few instances do they include all of the small ditches. Ditches which have such early rights that it is seldom necessary for the water commissioners to regulate them, and those which head on the lower sections of the streams and are supplied by seepage and are therefore not regulated by the water commissioners, were not included in the records of diversions. For the same season records of stream flow were kept by the United States Geological Survey. From the records of stream flow and diversions the following table has been compiled. This table shows the average flow of the stream for each month, the average volume of water diverted, and the difference between the stream flow and the diversions.

*Return seepage to tributaries of South Platte.*

[Cubic feet per second.]

Stream and date.	Flow.	Diver- sions.	Excess of flow.
<b>Clear Creek:</b>			
May, 1903.....	249	193	56
June, 1903.....	806	540	266
July, 1903.....	568	426	142
August, 1903.....	218	105	113
September, 1903.....	124	63	61
October (21 days), 1903.....	110	59	51
<b>St. Vrain Creek:</b>			
June, 1903.....	772	588	184
July, 1903.....	405	361	44
August, 1903.....	135	146	-11
September, 1903.....	67	99	-32
<b>Big Thompson River:</b>			
May, 1903.....	259	220	39
June, 1903.....	897	905	- 8
July, 1903.....	573	485	88
August, 1903.....	169	150	19
September, 1903.....	95	65	30

This table shows considerable excess of flow over diversions except in a few months. This, however, leaves out of consideration the small ditches before referred to. In order to make the measurements on the South Platte of value records of flow of these streams where they enter the Platte should have been kept, since any excess in these tributaries goes to supply ditches in the main stream. This would help to account for the large excess of diversions over stream flow in the South Platte from Denver to Julesburg. It is a fair assumption that after the flood period in June the diversions by the small ditches not included in the above records fully equal the excess of flow over recorded diversions. The South Platte may, therefore, be considered independent of these tributaries in the late summer. The following table showing return seepage to the South Platte River during July and August is based on this assumption and shows the gains in the river for those months:

*Return seepage to South Platte River, July and August, 1903.*

[Cubic feet per second.]

Section.	Dis- charge at upper station.	Diver- sions.	Dis- charge at lower station.	Gain.	Percent- age of gain.
<b>South Platte to Denver:</b>					
July.....	353	165	328	140	39.66
August.....	217	146	108	37	17.05
<b>Denver to Kersey:</b>					
July.....	328	631	192	495	150.90
August.....	108	384	137	413	382.41
<b>Kersey to Julesburg:</b>					
July.....	192	636	3	447	232.81
August.....	137	302	130	295	215.33
<b>River as a whole:</b>					
July.....	353	1,432	3	1,084	307.08
August.....	217	833	130	743	343.73

The single series of measurements made during August showed a gain of 730 cubic feet per second, while the records show an average gain for the whole month of 743 cubic feet per second.

NORTH PLATTE AND TRIBUTARIES.

A series of measurements covering the North Platte River from the Colorado-Wyoming line to Kearney, Nebr., was made during the months of August and September, 1903. The results of these measurements are given in the following table:

*Return seepage to North Platte River, 1903.*

[Cubic feet per second.]

Section measured.	Length of section.	Dis-charge at upper station.	Inflow.	Diver-sions.	Dis-charge at lower station.	Gain (+) or loss (-).	Gain (+) or loss (-) per mile.
Colorado-Wyoming line to above Douglas Creek	<i>Miles.</i> 8.00	260.22	0.00	0.00	216.90	- 43.32	- 5.40
Above Douglas Creek to above Sage Creek	52.00	216.90	279.06	56.54	273.70	-165.72	- 2.19
Above Sage Creek to Fort Steele	22.00	273.70	.00	.00	232.58	- 41.12	- 1.87
Fort Steele to Dickenson's ranch	21.00	232.58	.00	.00	239.32	+ 6.74	+ .32
Dickenson's ranch to below Medicine Bow River	11.00	239.32	18.05	.00	228.62	- 28.75	- 2.61
Below Medicine Bow River to below Sweetwater River	33.00	228.62	33.72	.00	271.92	+ 9.58	+ .29
Below Sweetwater River to Alcovia	12.00	271.92	.00	.00	275.10	+ 3.18	+ .26
Alcovia to Delaware Springs	21.00	275.10	.00	.00	257.85	- 17.25	- .82
Delaware Springs to below Muddy Creek	36.00	257.85	15.28	.00	343.98	+ 70.85	+ 1.97
Below Muddy Creek to Douglas	40.00	343.98	.90	.00	301.07	- 43.81	- 1.10
Douglas to above Horseshoe Creek	43.00	301.07	5.60	5.25	293.53	- 7.89	- .18
Above Horseshoe Creek to Guernsey Canyon	16.00	293.53	7.46	8.00	348.00	+ 55.01	+ 3.44
Guernsey Canyon to Whalen	14.00	348.00	.00	.00	355.37	+ 7.37	+ .53
Whalen to Fort Laramie	6.00	355.37	.00	71.74	273.15	- 10.48	- 1.75
Fort Laramie to above Rawhide Creek	9.00	273.15	7.73	42.49	315.67	+ 77.28	+ 8.59
Above Rawhide Creek to Torrington	8.00	315.67	.00	3.28	285.49	- 76.90	- 9.61
Torrington to Wyoming-Nebraska line	12.00	235.49	.00	121.04	234.58	-120.13	+10.01
<b>Total for Wyoming</b>	<b>364.00</b>					<b>- 85.10</b>	<b>- .23</b>
Wyoming-Nebraska State line to Mitchell (Sept. 1-25)	14.00	272.30	21.26	203.20	158.40	+ 68.04	+ 4.86
Mitchell to Gering	10.50	158.40	5.14	20.54	273.51	+130.51	+12.43
Gering to Bayard	18.50	273.51	.00	44.78	204.55	- 24.18	- 1.31
Bayard to Bridgeport	13.30	204.55	.00	34.00	284.35	+113.80	+ 8.56
Bridgeport to Oshkosh	45.50	284.35	36.42	4.35	246.95	- 69.47	- 1.53
Oshkosh to above Hayland canal	30.00	246.95	82.80	2.12	276.43	- 51.20	- 1.71
Above Hayland canal to Paxton Bridge	24.00	276.43	32.15	44.68	499.28	+235.38	+ 9.81
Paxton Bridge to North Platte	34.00	499.28	141.10	119.22	498.11	- 23.05	- .68
North Platte to Gothenburg	36.50	498.11	128.38	242.58	493.67	+109.76	+ 3.01
Gothenburg to Lexington	24.50	493.67	.00	30.17	298.71	-164.79	- 6.73
Lexington to Kearney	36.00	298.71	61.22	34.07	116.24	-209.62	- 5.82
<b>Total for Nebraska</b>	<b>286.80</b>					<b>+115.18</b>	

Throughout the entire course of the stream there are alternating gains and losses, the largest of both gains and losses occurring in the section immediately above the Wyoming-Nebraska line. There is a net loss of 85 cubic feet per second in Wyoming and a net gain of 115 cubic feet per second in Nebraska. The largest gain per mile on any part of the stream is in the section between Mitchell and Gering in Nebraska, where the land on both sides of the river is watered. The next largest gain is in the section just above the Wyoming-Nebraska

line, where the land is under ditch. East of Gothenburg on the main river very large losses occur, and these losses are known to continue beyond Kearney, where the measurements were discontinued.

A series of measurements was made during 1903 on the Laramie River also. These measurements extended from Woods Landing, near the Colorado-Wyoming line, to the mouth of the river. Both gains and losses are extremely small.

The following table shows the results of these measurements:

*Return seepage to Laramie River, 1903.*

[Cubic feet per second.]

Section measured.	Length of section.	Discharge at upper station.	Inflow.	Diversions.	Discharge at lower station.	Gain (+) or loss (-).	Gain (+) or loss (-) per mile.
Woods Landing to below Sodergreen's ranch.....	<i>Miles.</i> 5.00	76.36	1.80	62.21	34.74	+18.79	+3.76
Below Sodergreen's ranch to Bacon's ranch.....	4.25	34.74	11.10	.50	42.30	- 3.04	-.72
Bacon's ranch to below Cuba ditch.....	5.50	42.30	.00	.00	45.66	+ 3.36	+.61
Below Cuba ditch to above Sand Creek.....	5.00	45.66	.00	.00	41.74	- 3.92	-.78
Above Sand Creek to below Hutton ditch.....	2.75	41.74	.00	.00	42.39	+ .65	+.24
Below Hutton ditch to above Five-Mile Creek.....	4.00	42.39	.00	.00	44.92	+ 2.53	+.63
Above Five-Mile ditch to below Laramie.....	6.75	44.92	.00	.00	42.91	- 2.01	-.30
Below Laramie to Fisher's ranch.....	4.00	42.91	.00	.00	45.35	+ 2.44	+.61
Fisher's ranch to Oasis.....	6.00	45.35	.00	12.99	33.96	+ 1.60	+.27
Oasis to above Little Laramie River.....	6.25	33.96	.00	.00	31.34	- 2.62	-.42
Below Little Laramie River to below Boughton ditch.....	7.75	31.34	6.34	.00	40.44	+ 2.76	+.36
Below Boughton ditch to Union Pacific Railroad bridge.....	2.50	40.44	.00	.00	42.88	+ 2.44	+.98
Union Pacific Railroad bridge to Cooper Lake.....	3.00	42.88	.00	.00	46.85	+ 3.97	+1.32
Cooper Lake to Dunn's ranch.....	4.50	46.85	.00	.00	42.35	- 4.50	-1.00
Dunn's ranch to above Wyoming Development Co.'s reservoir No. 2.....	11.50	42.35	.00	.00	41.20	- 1.15	-.10
Below Wyoming Development Co.'s reservoir No. 2 to Dodge's ranch.....	9.75	169.45	.00	.00	169.27	- .18	-.02
Dodge's ranch to Wyoming Development Co.'s tunnel.....	8.25	169.27	.00	.00	169.79	+ .52	+.06
Above Wyoming Development Co.'s tunnel to below same.....	.75	169.79	.00	159.71	10.37	+ .29	+.39
Below Wyoming Development Co.'s tunnel to Northrop's ranch.....	14.00	10.37	.00	3.00	5.91	- 1.46	-.10
Northrop's ranch to below Combination ditch.....	7.00	5.91	.00	3.53	5.58	+ 3.20	+.46
Below Combination ditch to Mullen's ranch.....	6.00	5.58	.50	6.49	2.00	+ 2.41	+.40
Mullen's ranch to Uva.....	7.50	2.00	2.18	.00	6.14	+ 1.96	+.26
Uva to above Scisson's ranch.....	7.25	6.65	1.87	2.03	9.59	+ 3.10	+.43
Above Scisson's ranch to Guernsey's ranch.....	10.00	9.59	.00	8.44	4.52	+ 3.37	+.34
Guernsey's ranch to mouth of river.....	14.25	4.52	.00	5.38	8.82	+ 9.68	+.68

During the season of 1903 records of the flow of Deer and Horse-shoe creeks and the diversions from them were kept. The results of these measurements are given in the following table.



*Return seepage to Deer and Horseshoe creeks, Wyoming.*

Month.	Discharge at upper station.	Diver- sions.	Discharge at lower station.	Gain (+) or loss (-).	
				Acre- feet.	Per- cent.
<b>Horse-hoe Creek:</b>					
	<i>Acre-feet.</i>	<i>Acre-feet.</i>	<i>Acre-feet.</i>		
April .....	4,932	2,282	4,670	+ 2,020	+ 41
May .....	8,977	8,179	7,256	+ 6,458	+ 72
June .....	4,218	8,037	3,772	+ 11,191	+ 265
July .....	1,045	2,382	719	+ 2,066	+ 197
August .....	338	518	375	+ 555	+ 164
<b>Deer Creek:</b>					
April .....	12,200	721	10,067	- 1,412	- 12
May .....	26,010	4,479	21,522	- 9	00
June .....	8,330	2,810	7,795	+ 2,275	+ 27
July .....	485	1,149	343	+ 1,007	+ 206
August .....	80	368		+ 288	+ 360

This table shows that a very large percentage of the water diverted from these creeks returns in the form of seepage, so that the use of their waters for irrigation does not materially decrease their contribution to the flow of the North Platte.

**METHODS OF PREPARING LAND FOR IRRIGATION.**

During the past year a bulletin (No. 145) has been published describing methods of preparing land for irrigation. The demand for this bulletin shows the need for information of this practical character. Further information on this subject is included in the reports on irrigation in the Yakima Valley, Washington (pp. 267-278); in Modesto and Turlock districts, California (pp. 93-139), and the Imperial Valley, California (pp. 175-194). In sections of the arid regions where sagebrush grows its removal is the first step in reclamation. The usual method of removing sagebrush is by drawing over the land some heavy beam or iron which will break down or pull up the brush. Railroad rails are used for this, or heavy beams shod with iron and supplied with handles so that they may be kept in position. The railroad rails are sometimes bent into V-shape, and sometimes the base is notched to make it take a better hold on the brush. After the brush is broken down it is raked with horserakes made for the purpose, what has not been pulled up is grubbed by hand, and the brush is then burned. In some localities the brush is plowed out with gang plows. Single plows will not do this work, as they are thrown out of line by the roots, but heavy gang plows get enough hold on the ground to avoid this and cut off the roots. This method is not so common as that described first, and is not so easily available for the average settler as the first method. The statements of the cost of removing sagebrush range from \$1.50 per acre to \$5 per acre.

After the brush is removed the land must be brought to even slopes with smooth surfaces in order that water can be run over it easily. All kinds of scrapers and levelers are used for this, the most common

being made of plank set on edge, the lower edge being shod with iron to make it cut into the soil. These, drawn over the surface, will remove the soil from the high places and deposit it in the low places. Where large quantities of earth have to be moved ordinary scrapers such as are used for railroad and similar work are used. The cost of leveling land, after brush has been removed, varies, of course, with the original roughness of the surface and with the plan of applying water adopted, the reports from various sections giving it as from \$1 to \$15 per acre. The cost of laterals and division boxes also varies with the contour of the country and with the method of applying water. The total for the three items—removing brush, grading, construction of lateral ditches or checks—varied in the cases examined from \$3.50 to \$35 an acre. Add to this the price of a water right, from \$10 to \$20 an acre, and it is easily seen that the farmer under irrigation must have considerable capital to establish himself. It is also manifest that with an outlay so large the farmer can not afford to make many mistakes, either as to the tools or methods adopted, and no work that this Office has undertaken has proved more useful than the collection of information which will enable new settlers to do this work cheaply and well.

#### METHODS OF APPLYING WATER.

The effect on the yield of crops of applying water by different methods was tested in 1904 in a number of States. It is known that the various methods of applying water to land are not equally suited to all conditions and that what proves the best method in one place may not be so in other localities. The studies of 1904 were to determine the factors which influence this adaptability. In general, it may be stated that the check method is best adapted to light sandy soils having a comparatively even slope of from 3 to 15 feet to the mile. Fields having a steep slope should not be checked, since this requires levees so high and so close together as to interfere with the profitable use of farm machinery and also with diversified agriculture and rotation of crops. The advantage of checking is that it permits an irrigator to handle a large volume of water, and the cost of application is less than that of any other method. Its disadvantages are the removal of the surface soil to form levees, farm implements can not be used so conveniently and are frequently damaged in passing over high embankments, and the first cost of preparing the land is greater than by almost any other method.

The most common method of applying water in the arid region is by flooding from small field ditches. It is suited to the irrigation of all kinds of grain and grasses. It has the advantage of being cheap; it is adapted to most crops; the soil is not disturbed, and the small ditches used do not seriously interfere with the operation of machinery.

On the other hand, the labor of applying water to fields costs more and is more disagreeable than by any other method. It is difficult to control streams after dark or to distribute water evenly over fields in the nighttime, and where water is not distributed evenly the best results are not obtained.

Furrow irrigation is best for the irrigation of orchards and cultivated crops. The loss of water from evaporation is small. It permits of the use of smaller streams of water to better advantage than any other method. There is little displacement of the top soil, and the surface soil is not soaked and does not tend to bake or become too hard to cultivate. Its drawbacks are that land can not be watered so rapidly as by the other methods, and porous soils are hard to wet uniformly throughout the furrows.

The basin method differs from the check method in having the levees small and the basins much smaller than the checks. The use of basins is confined for the most part to orchards, where a basin is usually made for each tree. It has the advantage of allowing the use of a large head of water on small tracts and requiring little time for distribution. It produces an even watering on porous soils. It has the disadvantage of leaving the surface soil saturated and liable to bake. It requires considerable disturbance of the soil in forming the basins and is likely to keep the roots near the surface, since the water is applied there.

#### PUMPING.

In the reports of pumping investigations carried on in different sections the agents preparing these reports have used the units of water measurement common in the sections studied. For purposes of comparison these have been reduced to common units, which are used in the following discussion. The discharge of pumps is usually given in gallons per minute, but to reduce this to terms of depth on land requires several computations. In discussing pumping for irrigation we have used the acre-foot rather than gallons per minute, and in computing the cost of pumping water the unit foot acre-foot is used. This is secured by multiplying the number of acre-feet raised in a given time by the number of feet the water is lifted. Acre-feet is easily read in depth on land by dividing the number of acre-feet by the number of acres to be irrigated. For purposes of comparison with results from other pumping plants and for computing efficiency the results are also given in terms of "water horsepower hours," 1 foot-acre-foot equaling 1.375 horsepower hours. To compute the efficiency of a pumping plant it is necessary to compare the power developed by the engine with the power theoretically required to do the work done. The former is the indicated horsepower, the latter the water horsepower, and the efficiency is the ratio between the two.

## CALIFORNIA.

The study of pumping in California during 1904 included the collection of information as to plants in Santa Clara Valley, by Prof. S. Fortier; the collection of information regarding plants throughout the State, the testing of plants throughout the State, and tests of typical pumps, by Prof. J. N. Le Conte.

A part of the land in the Santa Clara Valley is supplied with water from streams which furnish water from January to March, but very little outside of these dates. Other lands must be supplied from wells, while some lands use both stream and well water. Copious winter irrigation and intense cultivation through the summer have produced crops on some orchards, while others are irrigated only during the summer from pumping plants. Reports were received from 60 plants in the Santa Clara Valley. The average lift reported is 66 feet; the average cost of water per acre-foot is \$4.38, and the average cost per foot-acre-foot is 6.6 cents. The average depth of water applied to lands watered by pumping plants is 1.13 feet.

The higher costs reported are for the smaller plants and those having the smaller lifts. The report of Professor Fortier gives a comparative statement of the cost of irrigating from streams and from pumping plants. The average depth of water used under ditches is 2.22 feet, and stream water is sold for \$2.10 per acre-foot, making a cost of \$4.66 per acre. Water is sold by the owners of pumping plants for \$13 per acre-foot, while the average depth is 1.13 feet, making the cost per acre \$14.69, or approximately \$10 per acre more than stream water. The average cost of pumped water for fuel and repairs is given as \$4.96 per acre, and fixed charges are estimated at \$5.20 per acre making the average cost of pumped water to owners \$10.16 per acre, or \$5.50 greater than the average cost given for stream water. The advantage of pumped water over stream water is that it can be secured as needed, while stream water must be taken as it comes, and the supply ordinarily lasts only from January through March.

The descriptions of pumping plants and data as to their operation collected by Professor Le Conte have not been brought together and reported upon. The report of Professor Le Conte (pp. 195-255) contains field tests of 19 pumps and laboratory tests of 7 pumps. The field tests show an average efficiency of 41.17 per cent for the plants tested, the minimum efficiency being 26 per cent and the maximum 65 per cent. Eight plants using gasoline for fuel and varying in size from 5 to 21 horsepower show an average cost of fuel per foot-acre-foot of 4.5 cents. Three steam plants from 12 to 27 horsepower and using crude oil for fuel show an average cost of 2.8 cents per foot-acre-foot. The average size of gasoline plants is 10 horsepower, while

the average size of steam plants is 21.8 horsepower. The cost, therefore, varies approximately with the size.

The laboratory tests included the running of pumps at various speeds with given heads and varying heads with given speeds. These tests showed very clearly that for each lift there was a definite head at which each pump worked most efficiently and, conversely, for a given lift a certain speed of pump gave higher efficiency than any other speed. A further test was made to determine the effect of the distribution of the head between the suction and discharge, but the results showed that within the limits within which centrifugal pumps may be run the distribution of the head between suction and lift made practically no difference.

#### NEW MEXICO.

The plan of the experiments at the New Mexico Experiment Station included a comparison of the cost of irrigating with stream water and with pumped water, but owing to the shortage of stream supply it was impossible to carry out these experiments (see p. 308). The experiments therefore included simply the keeping of a record of the cost of supplying water to different crops with pumps. On one field of alfalfa, which received water to a depth of 3 feet, the cost of pumping water was \$9.80 per acre. On another field of alfalfa, which received water to a depth of 3.1 feet, the cost was \$11.20 per acre. The average cost on 4 plats of wheat was \$3.70 per acre-foot. These plats of wheat received different volumes, the experiments being carried on in such a way that this cost can not be given on an acreage basis. Corn was irrigated in the ordinary way, receiving 25 inches of water, which cost \$3.30 per acre-foot, making the cost \$6.93 per acre. Sweet potatoes received 17.62 inches of water at a cost of \$4.86 per acre. The general average of cost per acre-foot at the station was \$3.44. The lift is not given.

#### TEXAS.

Mr. Harvey Culbertson, of this Office, spent the season of 1904 in western Texas, studying irrigation practice and giving advice to beginners as to equipment and irrigation practice. A report of his work is given on pages 319-340. In the last few years the shortage in the water supply in the Rio Grande Valley has led to the putting in of a large number of pumping plants in the vicinity of El Paso. The valley at this point is underlain by 30 to 40 feet of fine sand under which is a coarse gravel. Water is found throughout these sand and gravel strata, and so far the supply has proven ample. Other pumping plants are scattered throughout the territory visited by Mr. Culbertson, and tests were made of a number of these plants. Seven gasoline plants varying in size from 2 to 7 horsepower showed a fuel cost

of 7.6 cents per foot-acre-foot. Nine gasoline plants varying in size from 7 to 12 horsepower showed a cost of 7.5 cents per foot-acre-foot, with gasoline at 14 cents per gallon. The average quantity of gasoline used per foot-acre-foot was 0.43 gallon and the average lift 35 feet. The average discharge of pumps per acre irrigated for 31 plants was 10.54 gallons per minute.

Mr. Culbertson describes quite a number of storage reservoirs found throughout the country visited and estimates that by the storage of flood waters in the streams and the collection of storm waters in reservoirs very large areas might be reclaimed throughout this section.

Irrigation in the section of Texas lying to the east of the region visited by Mr. Culbertson was studied by Mr. A. J. Bowie, jr., of this Office. The district included in Mr. Bowie's report (pp. 347-507) lies south of the line through Del Rio, San Antonio, and Port Lavaco, with the addition of the Upper Nueces and Frio River valleys. In this section the area irrigated is approximately 30,000 acres, about half of which is in rice; corn, truck, and cotton occupy the next larger areas in the order named. Onion culture by irrigation is attracting a great deal of attention, but as yet no great acreage of this crop is reported. Mr. Bowie found that the average depth of water used by pumping plants was 2.67 feet; the average pump capacity per acre irrigated, 14.13 gallons per minute, and the pumps were operated 15.1 per cent of the time. Part of this irrigated land is watered from artesian wells and a part from pumped wells, the average cost for artesian wells is reported as \$57.77 per acre irrigated and \$7.46 per gallon per minute of discharge. The average cost of pumped wells is given as \$14.79 per acre irrigated and \$2.75 per gallon per minute of capacity of pumps.

It is seen that the cost of artesian wells is much greater than that of pumped wells, but in order that a comparison may be made the cost of pumping machinery should be added to the cost of pumped wells. The average cost of pumping machinery per acre irrigated is given as \$14.12 per acre. Adding this to the cost of wells, we have \$28.91 as the cost of wells and machinery per acre irrigated, against \$57.77 for artesian wells per acre irrigated, the cost of artesian wells being almost exactly double that of the others. The average annual cost of artesian wells per acre irrigated is given as \$8.63 and the average annual cost of pumped wells and machinery, \$6.13 per acre. These figures show clearly that on an average the pumped wells are cheaper than artesian wells, notwithstanding the fact that there is no fuel expense connected with an artesian well.

The following table shows the depth to which wells have been sunk in various sections in the territory studied by Mr. Bowie.

*Depth of wells in Texas.*

Location.	Depth.	Location.	Depth.
	<i>Feet.</i>		<i>Feet.</i>
Victoria.....	30-230	Moore.....	100
Inez.....	270	Pearsall.....	100-240
San Antonio.....	160-1,005	Derby.....	200
Beeville.....	59-225	Devine.....	110
Uvalde.....	100		

The cost of raising water per foot-acre-foot is given by Mr. Bowie as follows:

*Fuel cost of raising water in Texas.*

Fuel.	Cost.	Fuel.	Cost.
Wood.....	\$0.0164	All steam.....	\$0.0164
Coal.....	.0198	Gasoline.....	.0754
Oil.....	.0158	Electricity.....	.0351

This table shows that steam is by far the cheaper power, but the steam plants are larger than the others, which accounts in part for this difference. The extreme cheapness of both wood and crude oil in Texas is, however, the chief reason for the better showing for the steam plants. The above figures are for fuel cost, but labor is so cheap in Texas that the advantage is still maintained when taking into account the cost of attendance.

## LOUISIANA.

Two of the large pumping plants used for rice irrigation in southwest Louisiana were tested by Prof. W. B. Gregory (see pp. 509-544). One of these plants was equipped with a simple noncondensing slide-valve engine and centrifugal pumps, while the other was equipped with compound condensing Corliss engines and rotary pump. The fuel cost of raising water with the first plant was 2.4 cents per foot-acre-foot, and with the more expensive plant 0.9 cent per foot-acre-foot, the average for the two plants being 1.6 cents. This is very much cheaper than the cost shown in any other reports to this Office. This is accounted for by the large size of the plants and the cheapness of crude oil, which is used for fuel in that vicinity.

## ARKANSAS.

An experiment in pumping water for rice irrigation in Arkansas was carried on in 1904 in cooperation between this Office and the Arkansas Agricultural Experiment Station. This experiment was for the purpose of determining the character of the water supply, the cost of pumping, and the feasibility of raising rice in this section. Water was found at depths varying from 70 to 90 feet, and the supply is

apparently abundant, although only a few wells have so far been put down. Water rose to within 27 feet of the surface. At the experimental farm an 8-inch well was put down to a depth of 114 feet, at a cost of \$4 per foot, including pipe. The equipment consists of a 20-horsepower boiler and 18-horsepower engine and a 4-inch centrifugal pump, the entire cost of machinery being \$858.58. This plant was guaranteed to raise 470 gallons per minute, with a lift of 50 feet. The lift at starting was 27 feet, and pumping seemed to lower the water very little. The Fuller plant, in the same vicinity, equipped with a 25-horsepower engine, 35-horsepower boiler, and 6-inch centrifugal pump, supplies water to 70 acres. The cost for machinery and operation for the first year was \$3,147.50, or \$45 per acre irrigated.

#### KANSAS.

At the Fort Hays substation of the Kansas Agricultural College an experiment in pumping water for irrigating farm crops was made in 1904 (see pp. 567-583). Fort Hays is on the high plains where it was desired to determine both the extent of the water supply and the cost of bringing it to the surface with pumps. The well was placed in the valley of a small creek, near the bank, and water was struck at a depth of 24 feet. The well was put down to a depth of 40 feet, the water rising to within 24 feet of the surface. The well was made 13 feet in diameter. A 4-inch centrifugal pump, costing \$865.65, was used. The water supply in the well was very limited and was drawn down rapidly when the pump was run. A traction thrashing engine was used. The cost of raising water per foot-acre-foot, including fuel, engineer, and water tender, was 40 cents in 1903 and 30 cents in 1904. The machinery was too large for the work to be done and was poorly operated, which accounts very largely for the high cost of pumping in this locality. For these reasons the work in 1903-4 can hardly be taken as a fair test of the cost of pumping in this locality. The rapidity with which the water was drawn down in the well indicates that the water supply in this section is quite limited.

Tests of wells at Garden City, where water is pumped from the gravel at small depths, show that there also pumping lowers the water very rapidly. At the Richter well, 1½ miles west of Garden City, the water was lowered 5 feet in one hour and fifteen minutes. At King Brothers' well one test showed a lowering of 17.8 feet in five minutes, and another test showed a lowering of 17 feet in fifteen minutes.

#### COLORADO.

In the Cache la Poudre Valley in northern Colorado the water supply from the river has been so completely utilized that prices for water rights in both ditches and reservoirs have become so high that a great



many have deemed it cheaper to pump water for irrigation than to secure it from the stream. The extensive irrigation in this valley has raised the ground water so that water is found very near the surface, making pumping quite inexpensive. The wells reported on by Professor Stout (pp. 595-608) range in depth from 4 to 30 feet, and water was found at depths varying from 1.5 to 15 feet. The average cost of wells reported on is \$3.47 per acre served, the cost of pumps and engines \$6.25 per acre, making the entire equipment cost \$9.72 per acre, while ditch rights cost from \$25 to \$30 per acre. The average fuel cost of pumping water with gasoline engines and centrifugal pumps is given at 11 cents per foot-acre-foot, and with steam plants using local coal for fuel 8 cents per foot-acre-foot. In most of the wells the pump draws the water down very rapidly, but the wells soon fill up when the pumping stops. The wells are in general quite large pits, and it has been found necessary to put down pipes in the bottom of these pits in order to secure a sufficient supply of water. It is doubted whether the large pits are any advantage under these circumstances, as it is probable that the pipes put in the bottom of the pits would supply as large quantities if they were put down from the surface without the pits.

Pumps are being put in in the irrigated regions of the Arkansas Valley also. Here, as in the Cache la Poudre Valley, the extension of irrigation with river water has increased the cost of rights and raised the ground water, the two influences combining to make the pumped supply as cheap or cheaper than a supply from the stream. With gasoline at 20 cents per gallon the cost per foot-acre-foot was found to be 6.7 cents. The lift at Rockyford was 13 feet. At Lamar the lift was 10 feet and the cost per foot-acre-foot, 9.8 cents.

Bringing together the results from all the territory where studies of pumping were made we find that water is being successfully lifted for irrigation up to 100 feet, and in some cases more than that. In the following table the number of plants reported on for various lifts in the different sections are shown:

*Lifts through which water is being successfully pumped for irrigation.*

	Under 10.	10 to 15.	15 to 25.	25 to 50.	50 to 100.	Over 100.	Total.
California:							
Le Conte .....	0	0	0	5	11	3	19
Fortier .....	0	0	5	22	24	9	60
Arizona	1	0	0	5	0	0	6
Texas:							
Culbertson .....	0	0	0	20	0	1	21
Bowie .....	0	4	6	29	27	3	69
Tait .....	1	3	1	3	1	0	9
Louisiana: Gregory .....	0	0	2	0	0	0	2
Colorado:							
Stout .....	3	6	7	3	0	0	19
Wright .....	0	2	0	0	0	0	2

The larger number of plants reported on in California are lifting water from depths varying from 50 to 100 feet. The lift of the plants reported on in Arizona lie mostly between 25 and 50 feet. The same is true of the plants in Texas, the largest number having lifts between 25 and 50 feet, although a large number of plants have lifts between 50 and 100 feet. The lifts in Louisiana and in Colorado are low. All the plants reported on in Colorado are in irrigated sections where the use of water has raised the level of the ground water almost to the surface.

In the following table all the data contained in the reports regarding the fuel cost of raising water are summarized. This is given in terms of cost per horsepower-hour and cost per foot-acre-foot. The results given from California and Arizona plants were secured by careful tests. Those reported from Texas by Mr. Culbertson are results of tests. Those reported from Texas by Mr. Bowie are very largely made up from statements made by the owners of the plants and are therefore less reliable than the other results. The results from Louisiana were secured by tests, while those from Colorado are largely based on statements of the owners of the plants. There seems to be a general tendency to overestimate the discharge of pumps, and this fact probably accounts in part for the lower costs shown for Texas, although the cheapness of fuel and the large size of the plants would tend to make this cost lower than in other sections.

*Average fuel cost of pumping water for irrigation.*

CALIFORNIA (LE CONTE).

Type.	Number of plants.	Size.		Cost per water horse-power-hour.			Cost per foot-acre-foot.		
		Limits (useful water horse-power).	Average (useful water horse-power).	Highest.	Lowest.	Average.	Highest.	Lowest.	Average.
Gasoline.....	8	5.0-21.0	10.0	\$0.059	\$0.018	\$0.037	\$0.081	\$0.025	\$0.045
Steam, crude oil.....	3	12.0-27.0	21.8	.024	.015	.020	.033	.021	.028

CALIFORNIA (FORTIER).

Gasoline.....	7	0.5- 4.0	2.5	\$0.191	\$0.049	\$0.103	\$0.262	\$0.067	\$0.141
Do.....	6	4.0- 7.0	5.6	.103	.064	.087	.142	.088	.120
Do.....	8	7.0-10.0	8.7	.060	.029	.039	.082	.037	.053
Steam, crude oil.....	6	2.0- 7.0	5.3	.203	.081	.111	.279	.111	.152
Do.....	7	7.0-10.0	7.7	.100	.057	.073	.138	.078	.100
Do.....	6	10.0-12.6	11.0	.072	.039	.053	.099	.053	.073
Do.....	7	12.0-13.0	12.4	.057	.037	.049	.079	.051	.067
Do.....	6	13.0-17.0	14.4	.065	.032	.047	.090	.044	.065
Do.....	6	17.0-25.0	20.0	.074	.024	.044	.102	.033	.061

ARIZONA.

Gasoline.....	3	1.0- 7.0	4.0	\$0.076	\$0.049	\$0.063	\$0.104	\$0.067	\$0.087
Steam:									
Wood.....	5	1.0-33.0	10.0	.135	.020	.074	.186	.028	.102
Crude oil.....	1		60.0			.024			.031

*Average fuel cost of pumping water for irrigation—Continued.*

## TEXAS (CULBERTSON).

Type.	Number of plants.	Size.		Cost per water horse-power-hour.			Cost per foot-acre-foot.		
		Limits (useful water horse-power).	Average (useful water horse-power).	Highest.	Lowest.	Average.	Highest.	Lowest.	Average.
Gasoline.....	7	2.0- 7.0	4.4	\$0.097	\$0.035	\$0.055	\$0.134	\$0.048	\$0.076
Do.....	9	7.0-21.0	11.5	.055	.027	.041	.075	.037	.056

## TEXAS (BOWIE).

Gasoline.....	4	0.1- 0.4	0.2	\$0.232	\$0.152	\$0.184	\$0.320	\$0.210	\$0.253
Do.....	6	.4- 1.0	.6	.118	.058	.093	.163	.080	.128
Do.....	6	1.0- 2.0	1.5	.072	.039	.054	.099	.054	.075
Do.....	6	2.0- 4.0	3.4	.072	.050	.066	.099	.069	.077
Steam:									
Wood.....	6	1.0- 4.0	2.5	.140	.025	.057	.193	.034	.079
Do.....	7	4.0- 7.0	5.2	.070	.008	.029	.096	.008	.040
Do.....	5	7.0- 12.0	9.1	.046	.010	.021	.063	.013	.029
Do.....	4	12.0- 25.0	18.7	.022	.018	.021	.031	.025	.024
Do.....	6	25.0- 40.0	34.4	.040	.005	.017	.054	.007	.028
Do.....	5	40.0-160.0	90.3	.009	.007	.008	.012	.010	.011
Coal.....	2	1.0- 12.0	4.3	.066	.043	.055	.091	.060	.076
Do.....	2	12.0- 25.0	13.9	.038	.025	.032	.053	.035	.044
Do.....	2	25.0- 45.0	36.4	.023	.011	.017	.031	.016	.023
Do.....	3	45.0-100.0	72.9	.022	.008	.014	.031	.011	.019

## LOUISIANA (GREGORY).

Steam, crude oil.....	2	250.0-500.0	375.0	\$0.017	\$0.007	\$0.012	\$0.024	\$0.009	\$0.016
-----------------------	---	-------------	-------	---------	---------	---------	---------	---------	---------

## COLORADO (STOUT).

Gasoline.....	9	1.0-5.0	2.9	\$0.128	\$0.041	\$0.082	\$0.176	\$0.056	\$0.111
Steam, coal.....	3	2.0-8.0	4.5	.073	.039	.058	.100	.054	.080

## COLORADO (WRIGHT).

Gasoline.....	2	1.0-2.0	1.2	\$0.074	\$0.049	\$0.061	\$0.102	\$0.067	\$0.084
---------------	---	---------	-----	---------	---------	---------	---------	---------	---------

The fact most strongly brought out by this table is the great reduction in cost per unit of output with the increase in the size of plants. There is some reduction in the labor of operating plants as the size increases, and also in the first cost of plants per unit of area served. This brings out the very great saving which may be brought about through cooperation between adjoining farmers in putting in large pumping plants to serve several farms rather than maintain individual plants.

Reduced to a fuel basis rather than cost basis, the California results show approximately one-half gallon of engine distillate used per foot-acre-foot of water, while Mr. Culbertson reports from Texas the use of 0.43 gallon of gasoline per foot-acre-foot.

The tests of efficiency of the plants in California show that the average efficiency of the plants tested is 44.17 per cent. This efficiency is the ratio between the indicated horsepower developed by the engine and the horsepower theoretically required to lift the water actually delivered through the observed distance. It is estimated that good machinery properly operated will show an efficiency of about 65 per cent. The causes for the poor showing made are given as poor connections between engines and pumps, too large engines for the work to be done, poor care of machinery, and, with gasoline plants, wasteful use of gasoline; with steam plants, uncovered steam pipes and boilers. Most of these causes of loss can be cheaply remedied by exercising a little more care in the installation and operation of the machinery.

WINDMILLS.

The constancy of the winds on the great plains suggests the windmill as a promising source of power for pumping water, and windmill irrigation has had a successful development in the vicinity of Garden City, Kans. Facts as to the cost of mills and pumps, and the areas of land irrigated from them, were collected in this vicinity. One hundred and seven mills, varying in diameter from 6 to 12 feet, were visited (pp. 589-592). The average discharges of the pumps operated by these mills are shown in the following table. The second column gives the average amount pumped in a day with a good wind. In the third column are given the average discharges during twenty weeks, which takes into account times when there was too little wind to operate the pumps:

*Average discharge of pumps operated by windmills at Garden City, Kans.*

Size of mill.	Acre-feet per day.	
	In good wind.	Average for 20 weeks.
<i>Feet.</i>		
6	0.034	0.010
8	.080	.024
10	.170	.050
12	.270	.084
25	1.200	.386

The average area served by these mills is shown in the following table:

*Areas served by windmills of different sizes.*

Size of mill.	Maximum.	Minimum.	Average.
<i>Feet.</i>	<i>Acres.</i>	<i>Acres.</i>	<i>Acres.</i>
6	2.50	0.50	1.15
8	3.50	.25	1.23
10	6.00	1.00	3.08
12	12.00	1.00	5.07
25			8.00

The approximate cost of mills of various sizes, the areas served by these mills, and the acre cost of providing a water supply are given in the following table:

*Cost of windmills.*

Size of mill.	Cost.	Area served.	Cost per acre.
<i>Feet.</i>		<i>Acres.</i>	
8	\$90	1.23	\$73.17
10	120	3.08	38.96
12	150	5.07	29.59

This table shows the great reduction in cost per acre served by using large mills, but it also shows that with any mill the original outlay is quite large when compared with the cost of ditches for supplying water where water can be conveniently secured from streams.

The average annual cost of maintenance, including repairs, oil, etc., for 43 mills in the vicinity of Garden City, Kans., is given as \$2.35 per acre irrigated by the mills.

A windmill does not furnish a large enough stream of water for economical use in irrigation. It is therefore necessary to provide reservoirs for storing the water until enough is accumulated to furnish a stream large enough for economical use. Forty-nine reservoirs storing water pumped by mills at Garden City were measured to determine the capacity ordinarily used with the mills. The following table gives the approximate average capacities of the reservoirs used with the mills of different sizes:

*Capacities of reservoirs used with windmills.*

Size of mill.	Capacity of reservoir.
<i>Feet.</i>	<i>Cub. feet.</i>
6	3,400
8	3,400
10	4,000
12	11,000

The period during which these reservoirs will hold the discharge of the pumps during good winds is shown in the following table:

*Length of period reservoirs will hold discharge of pumps.*

Size of mill.	Number of days.
<i>Feet.</i>	
6	2.3
8	1.0
10	.6
12	1.0

It is probable that better results might be secured if larger reservoirs were built, so that larger streams might be used in applying

water to land. There is always waste in using a small stream, as a large part of the water is absorbed by the soil or evaporated while it is being spread over the land. The average cost of these reservoirs is given as \$60. This of course is only a rough approximation.

Taking the 12-foot mill as a basis, we have the following statement of the cost of raising water with a windmill, not taking into account the cost of the well and pump:

<i>Cost of windmill irrigation.</i>	
Cost of mill.....	\$150.00
Cost of reservoir.....	60.00
	<hr/>
Total cost.....	210.00
	<hr/>
Area irrigated.....acres..	5
Cost per acre.....	\$42.00

## ANNUAL COST.

Interest on investment, at 7 per cent.....	\$2.94
Depreciation, 10 per cent.....	4.20
Maintenance.....	2.35
	<hr/>
Annual cost per acre.....	9.49

The average lift of water in the vicinity of Garden City is but 10 feet. Where lifts are greater, the quantity of water raised by mills of the same size will be proportionately decreased, and the area which can be irrigated will of course be decreased in the same proportion. These figures represent not necessarily good practice, but the average results obtained under field conditions. It is probable that in most cases better results than those shown can be secured, but the work this year has been largely to secure a basis for future work by determining what is now being accomplished with windmills.

The average cost shown above is high, and even under the best conditions windmill irrigation is expensive, but it is not expected that water will be raised in this way for general farm crops. The quantities of water required for such crops and the low values of yields will not justify any such expense. Only the irrigation of vegetables and fruits and a small amount of forage is contemplated, and these are all high-priced products. A part of the expense of pumping, on the plains at least, may be charged to insurance against drought, since it is intended to enable farmers to tide over dry years when they would otherwise be compelled to abandon their ranches or buy food for themselves and work animals at exorbitant prices.

## LAWS AND INSTITUTIONS.

The three-years' investigation of the interstate water-right problems on the Platte River, mentioned in the previous reports, has been completed, and the report is now in the hands of the printer. This inves-

tigation deals fundamentally with the rights to water and the laws of the three States under which these rights have been acquired. Physical conditions, however, have such a marked influence upon the enforcement of these rights that the investigation included, in addition to the laws and court decrees governing water rights, measurements of stream flow, diversions, and return seepage. It was deemed advisable to include also something showing the results of irrigation in the three States, and crop returns were therefore collected. In order to discuss interstate questions intelligently, a preliminary study of the legal systems of the several States was necessary. This dealt with the methods of acquiring rights, methods of determining rights, provisions for their enforcement, and the nature of rights.

The method of acquiring the right to take water from a stream in Colorado consists essentially in providing the means of conducting the water to the point of use and taking the water. The method in Wyoming and Nebraska consists in making application to the State authorities, receiving a permit to construct works and divert water, putting the water to use, and submitting to the State authorities proof of the construction of works and the use of the water. As the result of these methods rights in Colorado are in the first place indefinite as to extent or nature, while in Wyoming and Nebraska they are limited by the terms of the permit granted by the public authorities. Since rights are indefinite in Colorado it became necessary to provide for their defining, and this is done by the courts under a special form of procedure provided by law. This procedure takes the form of a contest between individual appropriators, the State being unrepresented in the contest. As a result the courts have decreed rights to volumes much larger than have been used, and in many cases larger than the canals can carry. Under the administrative procedure in Wyoming and Nebraska such excessive rights have not been recognized.

In each of the three States water is distributed by public officials, the systems in the three States being essentially the same.

In each of the States priority is recognized, and in order that the right may be maintained it is necessary that the use of the water be continued; that is, no one can hold water unused or maintain his right to water for a period of years without having put it to a beneficial use or provided for its use by some one else. The courts of Colorado have decreed to appropriators in that State rights to fixed quantities of water, and these rights may be transferred from one party to another, and the use to which the water is put and the place of use may also be changed, provided others are not injured by the transfers. In Wyoming an appropriator acquires a right to sufficient water for a given area within a fixed limit of quantity, and this right may be transferred under certain limitations defined by statute. Rights in

Nebraska are similar to those in Wyoming, with the exception that the rights are inseparably attached to a particular tract of land. Neither Colorado nor Wyoming recognizes riparian rights, while Nebraska recognizes them to a certain extent. Under the decisions of the Nebraska supreme court lands acquired from the General Government previous to 1889 have riparian rights, while those acquired since that time have no such rights. Alongside of this riparian right has existed the right to divert water from streams for irrigation, and as between riparian rights and rights acquired by appropriation, priority governs, as it does between different rights acquired by appropriation. The riparian proprietor has not, however, the right to restrain diversions, but merely is entitled to damages occasioned by the diversion of water.

The differences in the nature of the rights in the three States are in theory important. Under the Colorado doctrine, that the appropriator has a right to a fixed quantity of water, any decrease in the needs of the land or economy in use leaves the appropriator a surplus, which he can apply to new lands or dispose of to others, while under the Wyoming and Nebraska doctrine any surplus of water arising from decreased use belongs to the State, to be disposed of in the same manner as unappropriated water.

The recognition of the ownership of water, apart from any particular tract of land in Colorado, makes it possible for rights to accumulate in the hands of those who hold them, for the purpose of disposing of water to others rather than for their own use. To prevent abuses of this right, the Colorado constitution provides that county commissioners may fix rates which may be charged for the use of water.

Each of the States recognizes priority as between appropriators within its own limits, and the courts of Wyoming and Nebraska, as well as of several other States and the United States courts, have declared that priorities should be recognized regardless of State lines. Assuming that priorities are to be recognized regardless of State lines, we have rights differing essentially in their nature along the same stream. If an appropriator from the South Platte in Colorado does not need for the land which he has been irrigating all the water to which he has a right he may apply the surplus to new lands or transfer it to another party, while, under similar circumstances, the Nebraska appropriator from the same stream must allow the water to remain in the stream for later appropriators. The effect of this difference from an interstate standpoint is that improvements in practice and the natural decrease in the needs of the lands now irrigated in Colorado will not increase the supply of water for Nebraska since it will be used upon new lands in Colorado. If the Nebraska doctrine



held in Colorado, this decrease in the needs of the lands in Colorado would go to the stream to supply later rights whether they were in Colorado or Nebraska.

However, physical conditions and the order in which rights have been acquired make these distinctions in rights of little consequence at present. The nature of the country along the North Platte in Colorado is such that the use of water there can not be enlarged to the injury of Wyoming appropriators from the same stream, and the same thing is very largely true regarding the country along this stream in Wyoming. There is very little land along the North Platte in Wyoming which can be irrigated except in the region immediately above the State line. There is a possibility of an increased use which would injure appropriators in Nebraska, but the nature of the rights in these two States is essentially the same, the appropriator in each State being entitled to only sufficient water for a given area.

There are rights to water from the South Platte in Colorado earlier than any rights in Nebraska sufficient to entirely exhaust the stream, and the flow of the stream has in fact been entirely used in Colorado for many years, while there is up to the present time very little irrigation along the South Platte in Nebraska. Measurements of return seepage given on pages 48-50 show that the volume of water in the lower section of the stream in Colorado is increasing year by year and practically all the water received by appropriators in Nebraska, except during floods, is return seepage water. As the volume of water in this section of the stream increases, irrigation is being extended, and this will in turn increase the seepage farther down, so that there is every prospect that the supply in Nebraska will grow better.

Physical conditions are such that there is little likelihood of any conflict between appropriators in the different States on the North Platte and the South Platte, except in the immediate neighborhood of the State lines. Here there will be the same opportunity for conflict as there is between canals heading close together within the States. At present there is no provision for the settling of such conflicts except through the courts. Each State has officials charged with the distribution of water within its limits, but none of these officials has any authority outside of his own State. The interstate question on the South Platte comes down then at the present time to a question of distribution. Provision should be made for some officials or boards with interstate powers.

A study of the operations of the California irrigation district law was made in 1904 by Mr. Frank Adams (see p. 96). Mr. Adams made a study of the history and present conditions of the Modesto and Turlock irrigation districts. These districts were originally organized against strong opposition and have gone through unsuccessful attempts

to construct works and attempts to repudiate their bonds, and have finally completed their works and begun operations. Modesto district contains an area of 81,143 acres and has a bonded indebtedness of \$17.10 per acre. Turlock district has an area of 176,210 acres and a bonded indebtedness of \$6.81 per acre. The California district law requires that the water of the canals belonging to the districts be distributed in proportion to the assessments paid. Town property as well as farm property is subject to assessment, and a strict enforcement of the law would place in the hands of those who had no use for it the right to a large part of the water supply by the district canals. In these districts no attempt has been made to enforce this law, but the water is distributed in proportion to the acreage irrigated. A system of rotation has been adopted, so that each irrigator receives a good stream of water, the length of time which he receives this stream being apportioned to the acreage irrigated. This system has so far proven satisfactory, but its continuance will bring about strong opposition to the enforcement of the law when the demand for water becomes so strong that every taxpayer in the district demands his share. At the suggestion of Mr. Adams the districts have adopted a system of records which will show the quantity of water received by each farmer and the time when he receives it. These records will form a basis for an intelligent consideration of a new system of distributing water when there is a demand for an enforcement of the law.

Mr. W. F. Bartlett, of this Office, was detailed for the season of 1904 to work in cooperation with the State engineer of Idaho. He was commissioned water master for the Raft River, a stream which rises in Utah and flows into Idaho. The State of Idaho enacted a law in 1903 providing for the distribution of water by State officials, and Mr. Bartlett's work was to make a study of the operation of this new law from the standpoint of one charged with its enforcement. His chief difficulty was one of detail. The law requires that appropriators shall put in measuring devices and provides that in case they fail to do so these shall be put in by the water commissioner and the costs assessed against the ditch owners. Mr. Bartlett found a great deal of opposition to the putting in of these boxes by the ditch owners and a disinclination to pay the bills assessed against them when the measuring devices were put in by the water commissioner. This state of affairs compels the water commissioner to carry the cost of installing the measuring devices for two or three months and take the chances of his bills being disallowed by the county commissioners, and Mr. Bartlett points out the necessity of amending the law regarding this matter in such a way that either the State or the county will carry this expense until it can be collected from the ditch owner. As above stated, Raft River is an interstate stream, and the courts of both Utah and Idaho have declared in favor of the recognition of priorities

regardless of State lines. There is here the same difficulty that exists on the Platte River, that there are no officials with interstate powers.

In connection with a study of irrigation practice in the Imperial Valley, California, Mr. Roadhouse, of this Office, made a study of the organization of the mutual companies controlling the laterals which supply this valley with water. The company owning the canal and lands gives to each purchaser of land and water for each acre a share of stock in the company controlling the lateral which will serve the land purchased. The holders of this stock control the affairs of their laterals, making assessments to cover the expenses of maintenance and operation. This same plan of organization is in some instances extended to the sublaterals, the water users organizing in this way for the cleaning and general maintenance of their small ditches. The same system is found in the Arkansas Valley in Colorado, where it has proven very satisfactory. It puts upon the farmers the responsibility for the condition of their own lateral ditches, thus removing one very fruitful source of friction between the farmers and the canal management. Mr. Adams recommends the same system for the Modesto and Turlock districts in California.

A study of the laws of Montana has been made by Professor Fortier, of this Office, and the report of his work is now in hand.

The operation of the irrigation laws of Nevada has been studied by Mr. J. D. Stannard, formerly of this Office, and Mr. A. E. Chandler, formerly State engineer of Nevada.

In November, 1904, at the request of the Department of Justice, Dr. Elwood Mead was detailed to assist in protecting the interests of the Government in the litigation over the water rights of the Arkansas River, this being an interstate case of great importance to which the Government is a party. This case is to determine the rights of irrigators in different States to the water of an interstate stream. The principle established here will govern similar cases throughout the arid region, and will have an important influence in shaping further developments.

## **IRRIGATION IN THE HUMID SECTIONS.**

### **RICE IRRIGATION.**

The water used on several fields in the rice districts of Louisiana and Texas was measured during the seasons of 1903 and 1904, and it is found by comparing the results of these measurements with those made in 1901 and 1902 that the tendency is to use less water than formerly. It is found that a deep covering of water prevents the proper warming of the soil by the sun's rays and produces spindling plants, which are easily blown down by the wind. In many places

the rice grown on levees and other high ground is better than that on the lower parts of the fields, where the water stands continuously. For these reasons the tendency is toward the use of less water. This conforms to irrigation practice of northern Italy, where it is seldom that the water covering is more than 2 or 3 inches deep. The following table gives a summary of the measurements of the water used in rice irrigation for four years:

*Summary of results of measurements of the amount of water used in rice irrigation for the years 1901, 1902, 1903, and 1904.*

Year.	Location of station.	Depth from canal.	Rain-fall.	Total depth.	Evaporation.	Net depth. <sup>a</sup>	Season. <sup>b</sup>	Average evaporation per day.
		<i>Inches.</i>	<i>Inches.</i>	<i>Inches.</i>	<i>Inches.</i>	<i>Inches.</i>	<i>Days.</i>	<i>Inches.</i>
1901 <sup>c</sup>	Crowley, La.....	16.47	10.04	26.51	14.47	12.04	63	0.230
1901 <sup>c</sup>	Raywood, Tex.....	19.66	9.15	28.81	16.03	12.78	71	.226
1902 <sup>d</sup>	do.....	19.71	11.08	30.79	11.08	13.34	91	.122
1902 <sup>d</sup>	Lake Charles, La.....	23.64	7.10	30.74	11.63	19.21	77	.150
1903.....	Estherwood, La.....	12.67	19.00	31.67	15.69	15.98	98	.160
1903.....	Eagle Lake, Tex.....	7.37	13.46	20.83	9.83	7.56-11.32	84	.117
1904.....	Estherwood, La.....	5.01	18.52	23.53	14.91	8.62	91	.164
1904.....	Crowley, La.....	5.44	20.54	25.97	13.30	12.68	98	.136
1904.....	Nottoway, Tex.....	14.12	19.97	34.09	18.25	15.84	119	.153
	Average.....	13.79	14.32	28.10		13.32		.162

<sup>a</sup> Water absorbed by soil and taken up by rice plants.

<sup>b</sup> Number of days in which rainfall and evaporation were measured.

<sup>c</sup> U. S. Dept. Agr., Office of Experiment Stations Bul. 113.

<sup>d</sup> U. S. Dept. Agr., Office of Experiment Stations Bul. 133.

<sup>e</sup> Using the mean of No. 6.

*Analyses of water used in rice irrigation.*—Many of the streams along the Gulf coast have so little fall that a slight lowering of the water by pumping produces an inflow of salt water from the Gulf. This inflow of salt water begins long before the supply of fresh water is exhausted. In 1902 a drought lowered the water level in the river and large quantities of salt water were run on the rice fields in their irrigation. It was found that young plants were killed by this salt water, but fields which had made a good growth were benefited by its use. It was feared, however, that the use of this salt water would bring about an accumulation of salt in the soil which would prove harmful in the future. The results of 1903 and 1904 have proved this fear to be groundless. The heavy rains of those years have so thoroughly washed out the salt that no difference could be observed between the fields irrigated with salt water in former years and those which have received none but fresh water. It is not considered advisable, however, to use salt water except in cases of extreme necessity.

A number of samples of water used for rice irrigation were analyzed to determine their salt content. The results of these analyses follow.

*Water analysis for irrigation investigation.*

[Parts per million.]

Laboratory No.	Location.	SiO <sub>2</sub> .	SO <sub>4</sub> .	HCO <sub>3</sub> .	Cl.	Ca.	Mg.	K.	Na.
1873	Halfway between Lowry and Houckts, La.	9.0	263.7	30.3	1,846.0	46.4	110.9	35.7	1,048.0
1874	Center of Grand Lake, La.	8.0	327.2	30.3	2,237.5	52.1	146.7	32.2	1,259.9
1875	Sea side of Mermentau dam	6.8	1,799.2	146.7	12,396.0	297.1	832.4	231.4	6,866.4
1876	Lower end of Grand Lake, La.	8.0	363.9	33.3	2,535.4	46.4	162.9	53.6	1,434.7
1877	Upper side of Mermentau dam	7.0	979.6	95.4	8,562.0	222.1	591.8	166.7	4,566.4
1878	Center of Lake Arthur, La.	11.6	247.2	27.2	1,704.0	42.1	105.2	38.8	961.9
1879	Mermentau Bayou, Mermentau, La.	14.0	87.7	27.2	781.0	27.9	46.7	21.5	429.7
1880	Upper end of Grand Lake, La.	8.2	290.1	30.3	1,974.9	52.9	126.2	32.2	1,110.0
1881	Center of Mud Lake	10.8	966.3	99.2	6,567.0	171.4	439.4	129.6	3,908.3
1882	Mermentau Bayou, mouth Bayou Quene de Tortue	15.2	90.7	36.3	710.0	22.9	44.3	14.2	398.2
	Bayou Quene de Tortue at Lichtenstein plant:								
1885	6 feet	12.0	197.0	15.1	1,455.5	50.0	98.2	29.4	781.5
1886	20 feet	10.6	193.7	18.2	1,349.0	41.4	82.9	29.4	763.0
1883	Well, sec. 10, T. 11, R. 7	15.4	101.0	284.6	57.0	46.4	19.4	3.1	100.2
1884	English Bayou, From J. A. Myers, Gueydan, La.:	18.0	9.0	39.4	14.0	5.7	6.5	2.6	7.5
2024	4 feet	6.7	4.0	24.2	80.0	8.6	5.7	4.2	39.6
2025	21 feet	6.5	3.5	24.2	80.0	6.4	5.4	4.0	42.7

Laboratory No.	Location.	Hypothetical combination.						
		Ca(HCO <sub>3</sub> ) <sub>2</sub> .	CaSO <sub>4</sub> .	MgSO <sub>4</sub> .	MgCl <sub>2</sub> .	NaCl.	KCl.	SiO <sub>2</sub> .
1873	Halfway between Lowry and Houckts, La.	40.2	124.1	220.1	264.5	2,664.0	68.1	9.0
1874	Center of Grand Lake, La.	40.2	143.5	282.4	356.5	3,201.8	61.5	8.0
1875	Sea side of Mermentau dam	194.8	846.8	1,502.0	2,103.6	17,500.5	441.7	6.8
1876	Lower end of Grand Lake, La.	44.2	120.7	348.4	368.5	3,646.0	102.4	8.0
1877	Upper side of Mermentau dam	126.7	648.7	652.1	1,824.5	11,604.7	316.3	7.0
1878	Center of Lake Arthur, La.	36.1	112.9	208.4	249.5	2,444.4	74.1	11.6
1879	Mermentau Bayou, Mermentau, La.	36.1	64.6	52.6	143.1	1,079.3	41.0	14.0
1880	Upper end of Grand Lake, La.	40.2	146.2	233.6	314.3	2,820.8	61.5	8.2
1881	Center of Mud Lake	131.7	472.3	791.1	696.5	9,932.2	247.4	10.8
1882	Mermentau Bayou, mouth Bayou Quene de Tortue	48.2	37.4	80.4	111.5	1,012.0	27.1	15.2
	at Lichtenstein plant:							
1885	6 feet	20.1	153.0	111.3	300.1	1,986.1	56.1	12.0
1886	20 feet	24.2	95.4	167.1	195.7	1,939.1	56.1	10.6
1883	Well, sec. 10, T. 11, R. 7	187.9				89.4	5.9	15.4
1884	English Bayou, From J. A. Myers, Gueydan, La.:	23.1		11.2		19.1	5.0	18.0
2024	4 feet	32.1	2.4	2.9	20.2	100.7	8.0	6.7
2025	21 feet	25.9		4.4	14.2	108.5	7.6	6.5

These analyses were made under the direction of Mr. J. K. Haywood, chief of the insecticide and water laboratory of the Bureau of Chemistry of this Department. A letter from Mr. Haywood respecting the interpretation of these analyses says:

The approximate quantity of the various salts, especially sodium chlorid, which are injurious to rice has not, to my knowledge, been determined. It is well known that rice can stand more sodium chlorid than most crops, but how much more I am

unable to state. I can therefore only give you interpretations based on the action of irrigation waters upon crops in general, and for this purpose will divide the waters into those that I am reasonably sure are very poor, those that are surely good, and those which under some circumstances might be good and under other circumstances bad.

I would say that the salt content of waters 1873, 1874, 1875, 1876, 1877, 1878, 1880, 1881, 1885, and 1886 is such that they would be pretty sure to cause trouble in a comparatively short time. Waters 1883, 1884, 2024, and 2025 could be used, especially in a moderately humid climate, without any fear of damage to crops. Waters 1879 and 1882 could very likely give good results in a moderately humid climate and on a light, loose soil, but in a very dry climate or upon a heavy clay soil they might cause damage in the course of time.

You of course understand that the above remarks only apply to these waters as they would be used in general irrigation practice. What effect the rains, which are to be expected in a climate like Louisiana, would have upon relieving the evil conditions caused by such waters as I have indicated as "poor" above, I am unable to state.

On the Mermentau River an attempt has been made to improve the water supply by damming out the salt water during the times the river is lower than the water in the Gulf and holding up the fresh water when the flow is toward the Gulf. The dam on the Mermentau was completed during the season of 1904, and to its existence is attributed the saving of the crop, as salt water entered the other streams so early as to make it impossible to secure sufficient fresh water for the complete irrigation of the rice.

The construction of this dam has called attention to the need of laws for the assessment of the cost of such works against those benefited. As originally planned, the Mermentau dam was to be paid for by voluntary subscription, but, as is usual in such cases, a number of parties benefited have refused to contribute to its cost. The estimated cost was greatly exceeded, and it was found impossible to raise the money by voluntary subscriptions. An appeal was made to the legislature of the State of Louisiana, and an act passed which created a board of commissioners for the Mermentau levee district, authorizing the following taxes: A tax of 2.5 cents per sack of rice raised by means of water from the Mermentau and its tributaries, and a similar tax on cotton, sugar, fruit, etc.; a tax of 10 mills on all property subject to taxation for levee purposes, the tax not to exceed 2.5 cents per acre on all lands subject to irrigation within the levee district, and \$50 per mile for all standard-gauge railroads within the district.

Common carriers were prohibited from receiving or removing produce on which the taxes were not paid. The law authorized the board of commissioners to issue bonds to the amount of \$200,000 to be used for work done or in the purchase of levees, locks, and dams within the district. A commission was appointed, but has never met. An injunction has been granted enjoining the board from performing any of the functions or exercising any of the powers con-

ferred upon it by law, or in any way attempting to carry into effect the provisions of the law. It would seem that some general law providing for the organization of districts similar to irrigation or drainage districts in other States would be preferable to such special laws as this. In such districts in other States only the tax on land is levied and only such a tax is considered good security for the bonds issued. The passage of such a district law, under which the cost of dams to keep out the salt water and other improvements could be equitably assessed against the lands benefited, would greatly promote the rice industry by putting within the reach of those communities a convenient means of raising money for the construction of these works.

The success of rice growing in Louisiana and Texas has led to experiments in its culture in other sections, particularly in the State of Arkansas. This State contains large areas of level prairie lands which have not been successfully farmed with other crops. They are very wet during the spring, but during the late summer and fall are very dry. For several years farmers in the vicinity of Lonoke have been experimenting with rice, and during the season of 1904 this Office, in cooperation with the Arkansas Experiment Station, conducted an experiment in the vicinity of Lonoke to determine the possibility of profitably raising rice on the prairie lands. Ten acres were broken up and prepared for planting, a well was dug, and a pumping plant purchased and installed.

An 8-inch well was sunk on the experimental plat. Water was struck at a depth of 70 feet and the well penetrated the water-bearing strata 44 feet, making the total depth of the well 114 feet. The water rose to within 27 feet of the surface and was lowered but little by pumping, showing that there is a good supply at this depth. The well cost \$4 per foot, including casing and strainer, making the total cost \$456. The pumping plant consisted of a 20-horsepower boiler and an 18-horsepower throttling center-crank engine and a No. 4 centrifugal pump. These, with all the accessories, cost \$858.59. The shed covering the pumping machinery cost \$90, making a total cost of \$1,404.59. Eight acres were planted and watered. Owing to the wet spring a part of this land was seeded so late that part of the crop did not mature, and part of that which did mature did not fill properly. The crop from 3 acres was not thrashed, and that from 5 acres was poorly thrashed, owing to trouble with the machinery. The average yield estimated from the part of the crop which was thrashed was 64.6 bushels per acre. Those in charge of the experiment are of the opinion that in irrigating the rice some mistakes were made, accounting in part for the poor yield. It is hoped that a continuation of the experiment through another year will give more satisfactory results.

Mr. W. H. Fuller has put in a pumping plant for the irrigation

of rice near Carlisle, Ark. Mr. Fuller has a 10-inch well 140 feet deep, a 6-inch centrifugal pump, operated by a 25-horsepower engine, and a 35-horsepower boiler. The cost of Mr. Fuller's plant was as follows:

*Cost of pumping plant of W. H. Fuller.*

Pumping plant and accessories and well.....	\$1,782.35
Rice binder.....	135.00
<b>Total investment.....</b>	<b>1,917.35</b>
The annual expense for pumping plant, including fuel, oil, repairs, and attendance.....	405.40
Field expenses, including plowing, seed, seeding, harvesting, thrashing, etc.....	804.75
Interest on investment.....	134.21
<b>Total.....</b>	<b>1,344.36</b>

This pumping plant served 70 acres during the season of 1904. The investment therefore amounted to \$27.39 per acre, and the annual expense was \$19.21 per acre. The plant is considered sufficiently large to serve 100 acres, and on this basis the investment is \$19.17 per acre, and the annual expense \$13.44 per acre. The yield of 70 acres planted in 1904 was 5,225 bushels, or 74.6 bushels per acre. The cost of raising 1 bushel of rice was therefore 26 cents.

CRANBERRY IRRIGATION.

In cooperation with the Wisconsin Experiment Station, this Office in 1904 worked to determine the relations of frost to water conditions in the cranberry marshes of Wisconsin. The United States Weather Bureau has established stations in the cranberry-growing region for the purpose of predicting frosts, and this Office is at work to determine the measures of protection needed when frosts occur.

The experiments of the past year included treatment of the soil, drainage, and irrigation. It was found that on land which was well sanded temperatures remain much higher during cold nights than over undrained sections of bogs. This was strikingly illustrated during the month of August. Over the undrained bogs the temperature went to freezing or below, while on the sanded places it was nowhere less than 34° F. above, as will be seen by the following table:

*Temperatures over ordinary bog and sanded plats during August, 1904.*

Day of month.	Ordinary bog.	Sanded plats.
	° F.	° F.
2.....	32.0	43.0
8.....	26.0	34.0
22.....	30.5	40.0
23.....	30.0	37.0
26.....	32.0	36.5
30.....	28.5	37.0



The following table, giving hourly temperatures on drained and undrained bogs during the night of August 22-23, shows the effect of drainage in preventing frost:

*Temperatures over drained and undrained bog.*

Hour.	Drained plat.	Ordinary bog.
	°F.	°F.
9.30 p. m. ....	42.0	33.5
10.30 p. m. ....	39.5	33.3
11.30 p. m. ....	38.0	31.5
12.30 a. m. ....	37.5	30.0
1.30 a. m. ....	36.3	29.7
2.30 a. m. ....	35.5	32.5
4.30 a. m. ....	34.0	38.5

While sanding and draining tend to keep up the temperature over bogs, the only sure protection against frost is flooding. Where vines are flooded they are apt to be injured unless the water is drawn off quickly when the temperature rises. Hence effective frost protection requires such control of the water supply as will permit of the quick flooding of vines when cold weather sets in and the quick and complete removal of water when it ends. The work of this Office is being directed to working out the proper arrangement and size of supply and drain ditches to accomplish this result.

The water for flooding cranberry marshes is secured principally by storage, and this storage is accomplished chiefly by building dams or dikes across the slope to hold the water from larger areas of marsh above. These dams are usually constructed of peat, taken from the adjacent bog, and sand when it can be found within hauling distance. A dam of this kind 18 feet wide at the base, 10 feet wide at the top, and 4.5 feet high, was constructed at an expense of \$3.95 per running rod. This dam later had a sand facing put on it at an expense of approximately \$2 per running rod. A part of the peat used in the construction of the dam was taken from the inside of the reservoir, but it was found that removing the peat greatly increased losses from seepage.

The slope of the marshes is naturally slight, and the reservoirs created by building dikes across the slope are shallow, and there are great losses from evaporation. The loss from this cause during June and July, 1904, amounted to 13.82 inches, or a lowering of the water level during the season of between 1 and 2 feet. This large evaporation from a reservoir having an average depth of not more than 2 or 3 feet means the loss of a very large proportion of the total supply. The growing of vegetation within the reservoir is considered by some as a protection against this loss, but it is probable that the water given off by the leaves is equal to that which would be lost from an open-water surface. Increasing the depth of reservoirs decreases the

percentage of loss by evaporation, but in the sandy soils of this region it is apt to increase the losses by seepage. Some practical method of checking seepage losses will be of great help to water storage in the cranberry districts.

#### IRRIGATION IN PORTO RICO.

In the southern and southeastern portions of the island of Porto Rico irrigation is necessary to the raising of crops, and in many sections irrigation systems can be installed at a small outlay. In those sections irrigation will doubtless soon become an important factor in agriculture.

In the greater part of the island the rainfall is ordinarily sufficient for crops, but almost every year there is a period when the growth of crops, especially vegetables, fruits, and sugar cane, is checked by lack of sufficient rainfall. In cooperation with this Office the Porto Rico Experiment Station is testing irrigation on a part of the station farm at Mayaguez. This farm had previously been irrigated, there being remains of a diverting dam and of ditches covering the land. In 1904 experiments were made in the irrigation of sugar cane, grapes, tomatoes, eggplant, celery, cabbage, melons, and other truck crops. Ground has been prepared for the irrigation of lowland rice. Thirty or forty acres will be irrigated when the system is completed. Several sugar growers on the island have signified a desire to cooperate in experiments in the irrigation of sugar cane, and during the coming year such experiments will be carried on.

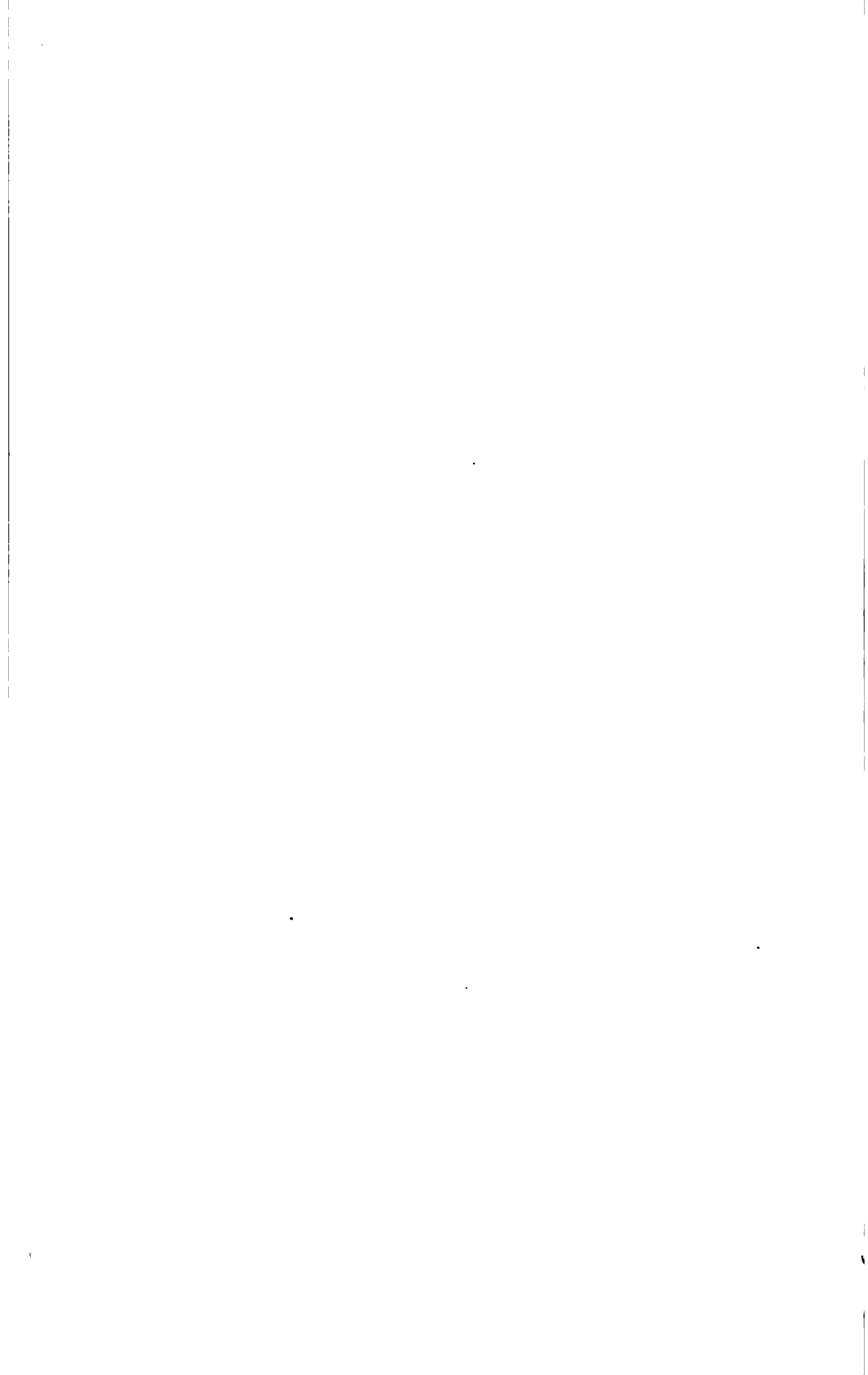

# IRRIGATION IN SANTA CLARA VALLEY, CALIFORNIA.

By S. FORTIER,

*Irrigation Engineer in charge of Pacific District.*

## INTRODUCTORY.<sup>a</sup>

Santa Clara Valley is the most important agricultural center in the neighborhood of San Francisco Bay. Beginning at the southern extremity of the bay with a width of 20 miles, the valley extends southward for 70 miles, narrowing to a few hundred feet 11 miles south of San Jose, the principal city in the valley, but widening again below that point as it extends southward into San Benito County. On the west the Santa Cruz Mountains separate it from the coast, some 40 miles away, and on the east a portion of the Coast Range lies between it and the San Joaquin Valley. The valley is drained toward San Francisco Bay by Guadalupe and Coyote creeks and their tributaries, and in its southern end toward Monterey Bay by several minor streams. As described by Profs. E. W. Hilgard and R. H. Loughridge, of the California Agricultural Experiment Station, it has a somewhat undulating surface, is dotted with clumps and groves of oaks, and has lands of black adobes on the northern or lower portions and lighter sandy or gravelly loams where the elevations are slightly greater. Excepting in the salt-marsh region near San Francisco Bay the valley proper is throughout highly cultivated, being devoted to the numerous deciduous fruits common to California—most largely to the prune, for which it has long been a leading center in this country. The yields of its fruits, and consequently the value of its orchards and vineyards, are high; its farm homes are widely known for their taste and comfort and for the convenience of communication and general orderliness which they possess. Besides the city of San Jose, with something over 22,000 inhabitants, it contains such prosperous town centers as Santa Clara, Los Gatos, Campbell, and Saratoga, making altogether a well-settled, well-utilized section. Its peculiarly sheltered

---

<sup>a</sup> Most of the field data pertaining to the duty and cost of water in the Santa Clara Valley were gathered under the writer's direction during the season of 1904 by Mr. F. H. Tibbetts, then a senior student in civil engineering in the University of California and now an instructor in hydraulics in the Lick School of Mechanical Arts in San Francisco. Mr. Tibbetts has also assisted in the preparation of this report for publication.

location with reference to San Francisco Bay conditions, however, as well as the peculiar conditions of soil, climate, and markets, its social advantages, and its people, give it a character somewhat different from what would usually be termed an average for California, although in its net results, as measured in the prosperity and intelligence of its people, numerous other sections of the State are readily comparable with it.

### SOURCES OF WATER SUPPLY.

The water supply of Santa Clara Valley is derived from two distinct sources, namely, from streams and from wells. The water from the streams is used for the most part from January 1 to March 31 of each year, under the usual designation of "winter irrigation." The water pumped from wells comes from the water-bearing sand and gravel beneath the surface, and is applied after the winter rains have ceased—that is, in "summer irrigation." The practice of using creek water in winter and the necessity for pumping water from wells in summer follow naturally from the fact that the creeks which drain the basin furnish a supply only during the rainy months of winter and spring.

For a period of nineteen years the mean annual precipitation at the town of Santa Clara was 16.06 inches, but of this total, 10.90 inches, or two-thirds, fell during the four months of December, January, February, and March. At the same place and for the same period the average rainfall from June 1 to September 30 was less than one-half inch. This uneven distribution of the annual rainfall might not cause so much difference in irrigation practice if a part of the precipitation could be withheld in the form of snow on high ranges; but on account of the mild winter climate and the low elevation of the Coast Range there is no snow, and only that part of the moisture which percolates into the soil and subsoil is held back. The orchardists might construct storage reservoirs and thereby retain a portion of the winter flow of the various streams of the valley, but experience has taught them that wherever the soil of the valley is deep and retentive of moisture a large amount of water can be stored therein. A reservoir formed by the open space in the subsoil beneath a cultivated orchard may not be the most effective, but it is very likely to be the least expensive and most convenient.

The experience of a large number of fruit growers during the past few years has clearly shown the feasibility and economy of winter irrigation. In consequence of this, creek water, which possessed little if any value ten or twelve years ago, being then permitted to flow unused to the bay, is now eagerly sought for and is yearly increasing in value. Of late years a large number of new ditches have been dug and existing gravity plants extended, so that now almost the entire

winter flow of these various crèeks is utilized. If the flow in the creeks were more plentiful, and if all the irrigable land were low enough to be readily reached by gravity canals, the need of pumping for irrigation would not be so urgent as it now is and the practice of winter irrigation would be greatly extended. Many would gladly irrigate in winter if water were available, because even if they preferred summer irrigation they would get along with a winter supply for the sake of saving the expense of purchasing and installing a pumping plant, as well as the extra expense for fuel, attendance, repairs, etc., incurred each season by raising the water supply from the wells. Few, however, have any option in the matter. The supply of water in the creeks is not sufficient for all, and much of the cultivated land is too high to be reached by gravity ditches from the creeks. Some of the most valuable land in Santa Clara Valley is thus located, and its owners must either pump water, purchase a supply from their neighbors' pumps, or do without irrigation.

The orchardists of the Santa Clara Valley may therefore be grouped under four heads: (1) Those who depend solely on winter irrigation and who obtain their supply from the creeks; (2) those who pump water either from the creeks or from wells; (3) those who purchase water each season from a neighboring plant; and (4) those who do not irrigate at all. These four groups, and particularly the first three, are not distinct. It frequently happens that an orchardist uses water from a creek ditch in winter or spring and from a well in summer. If the annual rainfall is heavy and the streams consequently high he may not start the pump during an entire season, keeping it rather as an insurance against drought in dry seasons. On the other hand, in dry seasons he may get little water from his usual creek supply and be compelled to depend entirely on pumping. Quite often a supply from a pump mingles with that from a creek. As regards the fourth group, some use no irrigation water from choice, others from necessity. Some are so situated that if they would obtain water they must raise it 100 feet, and the present low price of prunes will justify the cost of doing this in only a few cases.

The extent of the annual rainfall at Santa Clara has already been indicated. The precipitation there is representative of the precipitation throughout the main floor of the valley. In the foothills, however, it is considerably greater, being heaviest in the wooded sections of the Santa Cruz Mountains, from which most of the water supply is derived.

#### ORCHARD IRRIGATION.

The rainfall during the dry year of 1898 was a trifle more than one-half the normal. The year previous was likewise one of scanty water supply. These two dry years coming in succession, followed by others of medium precipitation, compelled a resort to irrigation, and thus

stimulated, a majority of the orchardists have come to count on irrigation as they count on cultivation. Previous to the dry period beginning in 1898 a limited area was winter-irrigated with water obtained from the creeks, but the prevailing sentiment was opposed to irrigation. The opposing sentiment was fostered by real estate men and others who, with land for sale, desired to create the impression that irrigation was unnecessary in their locality. The benefits resulting from a wise use of water in this valley have now, however, been clearly demonstrated. Some of the most apparent of these to the fruit grower have been the superior quality of the fruit produced, a greater regularity in bearing, and, more particularly, a large increase in yield. That these results have been obtained is admitted by nearly all fruit growers in the valley, and the conclusion seems also to be borne out by investigations made for the Office of Experiment Stations by Prof. E. J. Wickson, of the California Agricultural Experiment Station (see pp. 141-174). In cases where fruit has been damaged by irrigation the cause has usually been the application of too much water or its application at the wrong time.

There is a wide difference of opinion among the fruit growers as to the best time to irrigate and the proper amount of water to apply. Those who are dependent on the flow in the creeks and who irrigate in January, February, and March are apt to favor winter irrigation, while those who own and operate pumping plants are inclined to think that the advantages are chiefly to be found in applying the water in the late spring and early summer. In briefly comparing the advantages and disadvantages of these two methods, it may be said that, as regards the soil, the question hinges very largely on its depth and texture. A deep, retentive soil will hold a large part of the water applied in winter, and, being moist from frequent rains, will readily absorb what is applied on the surface. Porous, gravelly soils and subsoils, on the other hand, will lose by percolation much of the moisture applied, and such soils should be irrigated in the spring and summer, when the crops are in most need of moisture. In considering the loss by evaporation and percolation there is no decided net gain either way. Much of the water applied in summer from pumping plants is lost by evaporation, but probably very little, if any, drains from the soil. A large part is quickly absorbed by the trees. In winter irrigation the rate of evaporation is much less, but the time during which it acts is very much greater. Also, much of the water applied in winter undoubtedly drains away before the trees are able to make use of it. In comparing the cost of the two methods, the advantages are all in favor of winter irrigation. Creek water is cheaper and more plentiful, and there is a saving in labor, since less cultivation is required after each irrigation in winter than is required after each irrigation in summer.

**THE APPLICATION OF WATER PUMPED FROM WELLS.**

Water is applied to the orchards in furrows, in basins, and by flooding. The furrow and basin methods are used for water that is pumped from wells, while the flooding method is confined to low-lying, level lands that are irrigated from the creeks. The latter method is too wasteful of water to be adopted by the fruit growers who are obliged to use pumped water, and this discussion will be confined to the furrow and basin methods.

**FURROW METHOD OF IRRIGATION.**

The practice of furrow irrigation is gaining in favor in the Santa Clara Valley. Many who formerly used basins have adopted furrows. As a general rule, wherever conditions are favorable it is the most satisfactory way of applying water to orchards. The most favorable conditions are an even slope of from 10 to 20 feet to the mile and a soil of fairly uniform texture. When the slope is less than 10 feet per mile the size of the furrows should be increased, and when it is more than 20 feet per mile the size of the furrows should be decreased. The purpose of this adjustment is to reduce the flow on steep grades by cutting down the cross section, and to increase the size on flat grades to make up for the slow velocity. On very steep grades the trees of the orchards should be planted on grade lines of about 0.5 inch to the rod, in order to provide suitable slopes for the furrows.

In soils that are not fairly uniform in texture, water can not be evenly distributed by furrows. A strip of loose, porous soil, or a pocket of sand lying between compact soils, will intercept the flow. The result is uneven distribution and waste of water.

The number of furrows between the rows of trees varies in practice from 1 to 6, but is most frequently 4. For a light application of water, many prefer a deep furrow in the center of the space between the rows. This deep furrow, when made by a subsoiler, loosens the soil to a depth of 15 inches or more. In running water through it little is lost by evaporation, since it may be filled in with dry soil a few hours after the water is turned off. When four furrows are made between the rows they vary in depth from 5 to 10 inches and in length from 500 to 3,000 feet.

The head ditches of the valley are made of the orchard soil, and openings are made in the lower bank to feed the various furrows. There are a few exceptions to this. Some orchardists have provided head flumes of lumber with holes in the side to distribute water to the furrows. Others make use of short wooden tubes which are inserted in the ditch bank opposite the head of each furrow.



The amount of water turned into each furrow is much larger than in furrow irrigation in southern California and varies all the way from 5 to 12 miner's inches.

#### **BASIN METHOD OF IRRIGATION.**

For a fuller description of this method of irrigation, as well as of the furrow method, the reader is referred to Bulletin 145 of the Office of Experiment Stations<sup>a</sup>, which deals with methods of preparing land and applying water. In a preceding paragraph the general statement was made that under favorable conditions the furrow method of irrigation is to be preferred. In this connection it is well to state that some soils can not be successfully irrigated by furrows. In some soils of Santa Clara Valley the lateral percolation is so slow that surface flooding in basins is necessary. There are likewise cases where the flow through a furrow might run for days and not get beyond a sandy sump on its course.

It is claimed by those who prefer basins that the top layer of soil is the richest in plant food, that the rootlets of trees obtain much of their supply from the ingredients it contains, and that in consequence the top layer should be amply supplied with moisture in order to render this plant food available. On the other hand, there are some serious objections to the basin method, which the fruit grower should strive either to overcome, or, if that is not practicable, to lessen the injurious effects of. One of the greatest of these is the loss of water by evaporation from the moist surface soil and the consequent baking and cracking of the surface. The next objection is the amount of labor expended in preparing the basins to receive water, and, after it has been applied, the subsequent plowing, leveling, and harrowing which are necessary. As a rule, each irrigation calls for the twofold task of building levees around small inclosures and of afterwards leveling the surface to a uniform grade.

#### **THE DUTY OF WATER UNDER TYPICAL DITCHES OF THE SANTA CLARA VALLEY.**

In order to afford an opportunity to compare the duty of water under pumping plants with that under gravity ditches a summary of the results of measurements made on three ditches is herein introduced. Prior to the time of making these measurements, in the early part of 1904, little data could be obtained regarding either the capacities of the various ditches or the amount of water received by the users.

The method followed in determining the daily flow of each ditch was to insert a rating flume near the point of diversion or to use for

---

<sup>a</sup>U. S. Dept. Agr., Office of Experiment Stations Bul. 145.

this purpose a flume already in place. The elevation of the surface of the water in each rating flume was obtained by a recording instrument, and sufficient current-meter gaugings were taken to enable the investigator to make rating tables and compute from these the daily discharge.

The acreage irrigated under each ditch was obtained for the most part from the record books of the canal superintendents, and in doubtful cases the owners were interviewed. Extreme accuracy as to the extent of the land irrigated was not obtained, since both the acreage irrigated and the flow in the creeks vary considerably from year to year. The main purpose of this preliminary investigation was to obtain reasonably accurate figures pertaining to the duty of water under creeks, the waters of which were used for winter irrigation, and to compare these figures with those obtained in connection with pumping plants.

#### STATLER DITCH.

Statler ditch is one of four main ditches which divert water from Los Gatos Creek, and is used to irrigate a portion of the orchards in the vicinity of the town of Campbell. The association owning the ditch, which is not incorporated, consists of ten individuals. The surplus water is sold to outsiders, who paid in 1904 \$15 per day of twenty-four hours for a head estimated to contain 225 miner's inches, or 4.5 cubic feet per second, allowing 50 miner's<sup>a</sup> inches as the equivalent of 1 cubic foot per second. This ditch is between 4 and 5 miles long, is from 7 to 10 feet wide, and from 2 to 4 feet deep. Its maximum discharge in 1904 was 60 cubic feet per second and its mean discharge throughout the irrigation period of fifty days was 19.78 cubic feet per second. The area irrigated from this source from February 27 to April 23, 1904, was 1,241 acres, and the annual rainfall was 12.25 inches.

#### *Duty of water under Statler ditch, 1904.*

Duration of irrigation (February 27 to April 23).....	days..	56
Area irrigated .....	acres..	1,241
Discharge of ditch.....	acre-feet..	1,961
Depth of water applied.....	feet..	1.58

#### SOROSIS AND CALKINS DITCHES.

These ditches divert water from Campbell Creek at a point about 3 miles below the town of Saratoga. Since the headgates and some 600 feet of the upper portion of the ditch are operated in common, the

<sup>a</sup> There is a difference of opinion in the Santa Clara Valley as to the value of the miner's inch. Some have adopted the southern California "inch," measured under a 4-inch head, while others have adopted the statutory inch, which is measured under a 6-inch head, and is equivalent to the one-fortieth part of the standard unit of 1 cubic foot per second.

water measurements were made above the division point. Both ditches are owned by incorporated companies organized primarily for the purpose of selling the surplus water which remains after the needs of the stockholders have been supplied. Each company charges a uniform rate of \$20 per day of twenty-four hours for a head of water estimated to contain 1,800 gallons per minute, or 4 cubic feet per second. To avoid litigation, the companies have agreed to sell water to riparian owners on Campbell Creek at half rates.

The maximum combined discharge of the ditches was 91 cubic feet per second, and the mean discharge for the irrigation period, extending from February 12 to April 23, 1904, was 38.3 cubic feet per second. The annual rainfall for 1904 was 12.42 inches and the amount of water applied during the rainy season was 20.05 inches, or a total from both sources of 32.47 inches.

*Duty of water under the Sorosis and Calkins ditches, 1904.*

Duration of irrigation (February 12 to April 23).....	days..	70
Area irrigated .....	acres..	3,021
Discharge of ditches.....	acre-feet..	5,300
Depth of water applied.....	feet..	1.75

**PIONEER DITCH.**

Pioneer ditch diverts water from Almaden Creek in the foothills about 10 miles south of San Jose. Several causes combine to produce a lower duty of water here than under the two ditches just mentioned. The ditch being owned by a cooperative company, nearly the entire water supply is used by shareholders, who, having to pay no fixed charges for the water, are inclined to use it freely, if not wastefully. Another cause of the low duty is the longer irrigation season under this ditch. The ditch company is fortunate in possessing first rights on the stream and in having its headgates well up in the foothills, thereby gaining the water which would otherwise be lost by seepage in the sand of the natural channel.

The maximum discharge of the Pioneer ditch in 1904 was 24 cubic feet per second, and the mean discharge for a period of one hundred and fifteen days was 13.18 cubic feet per second. This amount of water, when applied to 900 acres, was sufficient to cover it to a depth of over 40 inches. The rainfall at San Jose was 13 inches, thus aggregating over 53 inches, less the loss in transit, that was received by the crops.

*Duty of water under Pioneer ditch, 1904.*

Duration of irrigation period (February 13 to June 7).....	days..	115
Area irrigated .....	acres..	900
Discharge of ditch .....	acre-feet..	3,004
Depth of water applied.....	feet..	3.34

The duty of water may be more readily comprehended by some if expressed in miner's inches per acre rather than in depth of water over the area irrigated. This has been done in the following summary. The value of the miner's inch herein used is similar to that of southern California, where 1 cubic foot per second is equivalent to 50 miner's inches.

*Miner's inch per acre irrigated.*

Statler ditch .....	0.797
Sorosis and Calkins ditches.....	.632
Pioneer ditch .....	.732

Assuming that the above-named ditches are representative of all the gravity ditches in the Santa Clara Valley, the average duty of water in 1904 as applied in winter irrigation was 0.72 miner's inch per acre.

**LOSS OF WATER IN TRANSIT.**

The figures which pertain to the discharge of ditches given in the preceding paragraphs are the results of measurements made near the head of each ditch. The aggregate in all the laterals which supply the farms under any one of the ditches under consideration would be considerably less on account of the losses arising from seepage, evaporation, and from other causes. An effort was made to determine in a general way what these losses were in five ditches. A suitable section was chosen in each ditch of from 1 to 2 miles in length and the discharges at both ends of the section were measured. The average loss as found by these tests was over 6 per cent of the flow per mile. Thus a ditch 4 miles long, according to this average, would lose about 25 per cent.

**FERTILIZING VALUE OF CREEK WATER IN SANTA CLARA VALLEY.**

The creeks of Santa Clara Valley carry a considerable quantity of sediment during the rainy period. In winter irrigation a part of this sediment is transported by the main canals and their distributaries and deposited with the water on the surface of the cultivated fields. The prevailing opinion among those who use creek water in winter is that this sediment possesses considerable value when compared with commercial fertilizers such as are usually applied to stone fruits.

For the purpose of ascertaining the commercial value of the sediment in the water samples were taken in March, 1904, and analyzed. Four samples of water, containing the usual amount of sediment, were taken from a small creek east of Los Gatos on the orchard owned by O. F. Van Dorsten. Three additional samples were taken on different days by D. R. Pender from a lateral which supplies his orchard. The lateral is part of a ditch system taking water from Los Gatos Creek,

and during the three days when samples were taken the water in it contained an average amount of sediment. These seven samples were mixed and analyzed by Prof. George E. Colby, of the University of California.

The results of Professor Colby's analysis will be something of a disappointment to many users of creek waters who believed that their irrigated fields were annually enriched from this cause. The report shows that the value of the sediment is 67 cents per acre. In arriving at this result the average depth of water applied over the surface of orchards in winter irrigation was first obtained. This average depth for 1904 was 2.224 feet, or 724,690 United States gallons per acre.

The following are the results of Professor Colby's analysis as given by him:

*Analysis of an average sample of water from creeks in Santa Clara Valley.*

Constituents.	Grains per United States gallon.	Parts per million.
Potassium sulphate ( $K_2SO_4$ ) .....	0.18	3.07
Sodium sulphate ( $Na_2SO_4$ ) .....	2.08	35.59
Sodium chlorid ( $NaCl$ ) .....	.33	5.66
Sodium carbonate ( $Na_2CO_3$ ) .....	.61	10.45
Sodium nitrate ( $NaNO_3$ ) .....	None.	None.
Magnesium carbonate ( $MgCO_3$ ) .....	1.69	24.93
Calcium carbonate ( $CaCO_3$ ) .....	4.14	70.87
Calcium sulphate ( $CaSO_4$ ) .....	.93	15.93
Calcium phosphate ( $Ca_3P_2O_8$ ) .....	.61	10.45
Iron and alumina ( $Fe_2O_3$ and $Al_2O_3$ ) .....	.28	4.79
Silica ( $SiO_2$ ) .....	1.45	24.83
Organic matter (large) and chemically combined water .....	1.45	24.83
Total .....	13.75	25.40
Free carbonic acid gas .....	Small.	Small.

According to the above table, and assuming that the average depth of creek water applied to each acre is 2.224 acre-feet, the total amount of mineral matter received by each acre would be 4,773 pounds. Of this total 3,500 pounds is sediment insoluble and not available for plant food; the balance, 1,273 pounds, may be subdivided as follows:

<i>Alkali.</i>	Pounds.
White alkali (sodium sulphate) .....	215
Black alkali (sodium carbonate) .....	63
Common salt (sodium chlorid) .....	36

Like most mountain stream waters this one is especially pure and admirably suited for the irrigation of fruit trees. None of the above-named salts is sufficient in quantity to injure deciduous orchards, which can tolerate 10,000 pounds of white alkali per acre and 1,000 pounds of each of the remaining two.

*Fertilizing ingredients.*

	Pounds.
Phosphoric acid .....	2.9
Soluble potash .....	10.1
Nitrogen .....	None.

The preceding table shows that the available potash carried to each acre of land by the water was 10.1 pounds valued at 50 cents, and 2.9 pounds of phosphoric acid valued at 17 cents, or that the total added value from the water was but 67 cents.

Five hundred pounds, the minimum amount applied per acre, of ordinary fertilizer for stone fruits contains available potash and phosphoric acid worth at least \$5. Thus it appears that over seven years of irrigation with this water, in the quantities used, would be required to furnish prune, peach, and apricot orchards with as much available plant food, containing no nitrogen, as is supplied by one little dressing of fertilizer.

### **THE COST AND DUTY OF WATER IN 1904 UNDER 60 PUMPING PLANTS IN SANTA CLARA VALLEY.**

During the irrigation season of 1904 measurements were made of the discharge of 68 irrigation pumps in Santa Clara Valley. The purpose of these measurements was to aid in determining, roughly, the service these pumps were performing and the cost of the water they raised. No technical refinement was aimed at, but the measurements were made carefully and the results are within practical limits of accuracy. During each test every effort was made to have the plant being tested run as nearly as possible under average conditions. Wherever practicable a weir notch of the trapezoidal form, 1 to 3 feet wide, cut in a rough board dam, was inserted in the ditch leading from the pump. In this connection it was generally necessary to build up the banks or to deepen the channels of the ditches in order to give sufficient depth below the weir crest to permit of accurate measurement. Measurements were taken of the depth of water on the crests at regular intervals, varying with the different weirs from a few hours to several days. In a few cases permanent weir boxes were installed and measurements made for the entire season. With a few of the larger plants the discharges were gauged with a current meter.

The results from 60 of the 68 plants tested are summarized and tabulated on page 88, together with data regarding the power used, the area irrigated, the total quantity of water used, the height it was lifted, and the various items of cost. The remaining plants are not embraced in the table because of their showing abnormal conditions. The plants are numbered for purposes of reference.

Summary of data concerning cost and duty of water under 60 pumping plants in Santa Clara Valley in 1904.

No. of plant	Power.	Dis-charge.	Area watered.	Amount of water raised during season.	Depth of water applied during season.	Height water raised.	Cost of water per acre.	Cost of water per acre-foot.	Cost of raising 1 acre-foot of water 1 foot (i. e. per foot-acre-foot).	Total cost of water for season.
		<i>Cu. ft. per sec.</i>	<i>Acres.</i>	<i>Acres-feet.</i>	<i>Fet.</i>	<i>Fet.</i>				
1	Steam	1.56	150	315.4	2.10	110	\$10.50	\$4.99	\$0.045	\$1,575
2	do.	1.10	19	35.6	1.87	50	10.37	5.54	.111	197
3	do.	.76	23.5	13.4	.57	140	5.83	10.22	.073	137
4	do.	2.34	25	38.7	1.55	28	5.96	3.85	.137	149
5	do.	2.34	15	14.5	.97	28	3.73	3.86	.138	56
6	do.	2.55	30	31.6	1.05	22	3.77	3.58	.163	113
7	do.	.90	22	11.6	.53	70	3.59	6.81	.097	79
8	do.	1.18	12.5	14	1.12	58	5.60	5.00	.086	70
9	do.	1.18	15	9.7	.65	58	3.20	4.95	.085	48
10	Gas	.72	12	14.4	1.20	50	8.33	6.94	.139	100
11	Steam	1.42	85	54.7	.64	75	3.80	5.90	.079	323
12	Gas	.92	22.5	17.8	.79	27	2.58	3.26	.121	58
13	Steam	1.04	18	5.1	.28	86	2.17	7.65	.089	39
14	Gas	.98	30	54.1	1.80	77	11.40	6.32	.082	342
15	do.	.72	25	14.3	.57	27	3.00	5.24	.194	75
16	Steam	1.88	34	21.2	.62	68	2.44	3.92	.068	83
17	Gas	.45	24	10.8	.45	44	1.83	4.07	.093	44
18	Steam	.75	20	16.6	.83	24	5.55	6.69	.279	111
19	do.	1.93	38	70.6	1.86	115	7.16	3.85	.034	272
20	Gas	.53	18	17.4	.97	46	6.89	7.13	.155	124
21	Steam	1.23	50	26.5	.53	88	3.34	6.30	.072	167
22	do.	1.32	55	74.5	1.35	88	5.96	4.40	.050	328
23	Gas	1.34	75	107.9	1.44	24	3.33	2.32	.096	250
24	do.	1.01	25	19.4	.78	27.5	1.44	1.86	.067	36
25	Steam	2.83	70	70.2	1.00	19.5	2.53	2.52	.129	177
26	Gas	1.29	10.5	49.4	4.70	52	8.95	1.90	.037	94
27	do.	1.29	11	46.5	4.23	52	8.09	1.91	.037	89
28	Steam	2.56	30	39.7	1.32	37	3.30	2.49	.067	99
29	Gas	2.07	19	44.2	2.33	43	4.21	1.81	.042	80
30	do.	2.07	16	24.5	1.53	43	2.81	1.84	.043	45
31	Electric	2.11	15	31.3	2.09	34	5.67	2.72	.080	85
32	Steam	.93	23	28.8	1.25	49	7.30	5.83	.119	168
33	do.	.92	21	16.6	.79	55	4.86	6.15	.112	102
34	do.	2.53	20	48.2	2.41	60	5.75	2.39	.040	115
35	do.	1.30	40.5	21.9	.54	93	4.52	8.36	.090	183
36	do.	1.55	24	22.4	.93	73	3.75	4.02	.055	90
37	do.	2.17	10	23.6	2.36	91	21.80	9.24	.101	218
38	do.	1.22	20	13.6	.68	121	3.65	5.37	.044	73
39	do.	1.29	35	26.8	.77	100	6.83	8.92	.090	239
40	do.	1.31	85	36.4	.43	85	2.56	5.99	.070	218
41	Gas	.82	70	33	.47	53	3.11	6.61	.125	218
42	Steam	1.87	40	45	1.13	80	9.18	8.15	.102	367
43	do.	.81	73	29	.40	118	3.07	7.72	.065	224
44	Steam	2.23	150	158.5	1.03	44	2.47	2.33	.058	370
45	do.	1.22	33	57.6	1.75	91	11.42	6.54	.072	377
46	do.	2.13	60	60.6	1.01	50	2.58	2.56	.061	155
47	do.	1.87	35	36.2	1.03	38	3.14	3.04	.080	117
48	Gas	1.17	35	28.9	.83	46	3.34	4.05	.088	117
49	do.	1.23	45	72.6	1.61	38	6.24	3.87	.102	281
50	Steam	1.86	34	55.4	1.63	40	5.09	3.12	.078	173
51	Gas	.22	30	14.6	.49	23	2.93	6.03	.262	88
52	do.	1.35	15	9.4	.63	63	2.13	3.40	.054	32
53	Steam	1.15	41.5	27.6	.66	102	4.17	6.27	.061	173
54	Gas	1.23	35	38.6	1.10	50	6.83	6.19	.124	239
55	Steam	2.70	1391	202.3	1.45	60	3.76	2.59	.043	524
56	Gas	.13	14	2.3	.16	43	1.00	6.09	.142	14
57	Steam	1.75	43.5	45.6	1.05	59	6.14	5.86	.099	267
58	do.	.58	21	9.5	.45	107	3.81	8.42	.079	80
59	do.	.71	241	20.6	.85	115	4.79	5.63	.049	116
60	Steam	.85	40	67.2	1.68	110	12.12	7.22	.066	485
Totals or averages			2,272.1	2,568.4	1.13	66	4.96	4.38	.066	11,261

Although somewhat cumbersome, the above table has been included because of the value it may have locally in the valley and because it may be useful for generalizations that will not be included in this report.

The significant figures of this table are largely grouped under the headings of costs. Other features, however, are interesting, and in the summaries below an attempt has been made to include such of them as seen especially useful. In each case the 60 plants are divided into groups in order to show the most common condition:

*Summary of 60 pumping plants classified according to the cost of raising 1 acre-foot of water 1 foot (that is, per foot-acre-foot).*

Number for which cost is under 5 cents per foot-acre-foot .....	10
Number for which cost is 5 to 10 cents per foot-acre-foot .....	31
Number for which cost is 10 to 15 cents per foot-acre-foot .....	14
Number for which cost is over 15 cents per foot-acre-foot.....	5

*Summary of 60 pumping plants classified according to cost of water per acre.*

Number for which cost is under \$5 per acre .....	35
Number for which cost is \$5 to \$10 per acre .....	19
Number for which cost is \$10 to \$15 per acre .....	5
Number for which cost is over \$15 per acre.....	1

*Summary of 60 pumping plants classified according to depths of water applied.*

Number for which depth applied is under 1 foot.....	29
Number for which depth applied is 1 to 2 feet.....	24
Number for which depth applied is 2 to 3 feet.....	5
Number for which depth applied is over 3 feet .....	2

*Summary of 60 pumping plants classified according to quantity of water discharged.*

Number for which discharge is under 0.5 cubic foot per second (225 gallons per minute) .....	3
Number for which discharge is 0.5 to 1 cubic foot per second (225 to 450 gallons per minute) .....	15
Number for which discharge is 1 to 2 cubic feet per second (450 to 900 gallons per minute) .....	29
Number for which discharge is 2 to 3 cubic feet per second (900 to 1,350 gallons per minute) .....	13

Of the 60 plants, the above classifications show the largest number to fall within the groups under which the duty of water is less than 1 acre-foot per acre, the cost of water per acre under \$5, the cost of each acre-foot of water raised 1 foot is between 5 and 10 cents, and the discharge of the pumps is between 1 and 2 cubic feet per second, or between 450 and 900 gallons per minute. If the 60 plants were further classified as above it would be found that for a majority the lifts are between 25 and 75 feet, that 38 are steam plants, 21 gas plants, and 1 an electric plant, and that the largest number of plants water areas of less than 25 acres.

The data given in the table above might be classified in a number of different ways according to the information desired. The summaries above show something of the prevailing practice as regards the more important matters covered by the table. Following are given a few deductions having particular reference to costs.



**RELATION OF COSTS TO LIFT.**

The table on page 88 shows that the average cost of raising 1 acre-foot of water 1 foot was \$0.066 for the 60 plants included. For 9 of the plants the height water was lifted was greater than 100 feet, yet of these 9 the cost per foot-acre-foot was in only two cases, numbers 3 and 58, above the average of \$0.066. If only the cost of fuel were to be considered, the cost of raising 1 acre-foot of water 1 foot would most probably increase with an increase in lift, but the cost of attendance changes this condition, and is very frequently found to be the same whether the lift is 30 feet or 100 feet.

**RELATION OF COSTS TO SIZE OF PLANTS.**

It may be stated as a general truth that the operating cost of pumping water should be less under large plants than under small ones, because large plants can, as a rule, be run more efficiently than small plants, and with but a slight increase over the small plants in the cost of attendance. The average cost per acre-foot of water under the 60 plants was \$4.38. Thirteen of the 60 plants had capacities of over 2 cubic feet per second, or of 900 gallons per minute, and the cost under these averages \$3.21 per acre-foot, the cost under all but one of the 13 plants being below the average of \$4.38 for the 60. Eighteen of the 60 plants had capacities of less than 1 cubic foot per second, or of 450 gallons per minute. The average cost of water per acre-foot for these 18 was \$6.47, the cost under all but two being above the average of \$4.38 for the 60. These comparisons bear out the general statement made at the beginning of the paragraph.

**COMPARISON OF THE COST OF WATER UNDER DITCHES AND UNDER PUMPING PLANTS.**

The average quantity of water used per acre during the early part of 1904 under a few typical ditches of the Santa Clara Valley was as follows:

	<i>Average quantity of water used per acre.</i>	<i>Acre-feet.</i>
Statler ditch .....		1. 58
Sorosis and Calkins ditches .....		1. 75
Pioneer ditch .....		3. 34
Average .....		<u>2. 22</u>

The officers of the Statler, Sorosis, and Calkins ditches, in addition to supplying the needs of their respective stockholders, sold water to outsiders at an average price of \$2.10 per acre-foot. If it is assumed that those who purchased water at this rate used as much as the stockholders, the average cost to the former would be \$4.66 per acre. It is reasonable to conclude, however that the purchaser of water from

a ditch company would use somewhat less than one who owned an interest in the company. This view is strengthened by the fact that during the year previous the average cost of water for winter irrigation on 130 orchards was \$2.50 per acre. It is therefore probable that \$4.66 per acre approaches the maximum cost of water for winter irrigation and that the average is considerably less.

As regards the cost of water under pumping plants, some orchardists, as has been stated, own their plants, while others buy water from a neighboring plant. In the case of the former the results of investigations show that the average cost for operation in 1904 was \$4.96 per acre. This sum included the cost of fuel, attendance, and slight repairs, but did not include any of the fixed charges which would probably average fully 13 per cent of the capital invested in the plant. In a plant which cost \$2,000 and irrigates 50 acres the fixed charges would amount to \$260, or \$5.20 per acre irrigated, which would increase the average cost from \$4.96 to \$10.16 per acre.

The cost of water under pumping plants may be more accurately determined, perhaps, by ascertaining the rates charged by the owners of plants for given amounts of water applied on adjoining orchards. These rates are usually expressed in dollars and cents per hour for the use of the stream of water which is discharged by the pump. The sale of water in this way has not proven wholly satisfactory, since few measurements of the amounts delivered have been made, and since the purchaser has seldom had any definite idea of the amount of water applied to his orchard in a given time. The discharges given in the following table were measured at various times, and the rates per hour were obtained from either the buyer or the seller.

*Prices paid for water from pumping plants in 1904 by Santa Clara Valley orchardists.*

No.	Rate per hour.	Size of stream purchased.	No.	Rate per hour.	Size of stream purchased.
		<i>Cu. ft. per sec.</i>			<i>Cu. ft. per sec.</i>
1.....	\$1.00	1.87	12.....	\$2.00	1.75
2.....	1.50	2.56	13.....	1.50	.85
3.....	.65	2.07	14.....	1.25	.81
4.....	1.25	.93	15.....	1.50	1.18
5.....	2.25	1.59	16.....	1.50	1.03
6.....	1.50	.92	17.....	1.50	.72
7.....	1.00	2.52	18.....	1.00	.84
8.....	2.00	1.87	19.....	1.50	1.92
9.....	1.25	1.35	20.....	1.75	1.23
10.....	2.50	1.60			
11.....	2.50	1.23	Average.....	1.55	1.44

The average rate for the 20 orchards listed in the preceding table is \$1.55 per hour for 1.44 cubic feet per second delivered, or at the rate of \$13 per acre-foot. If either this figure or the figure given in the preceding paragraph is used, the cost of pumped water is found to be over twice as much as the cost of creek water run in ditches.

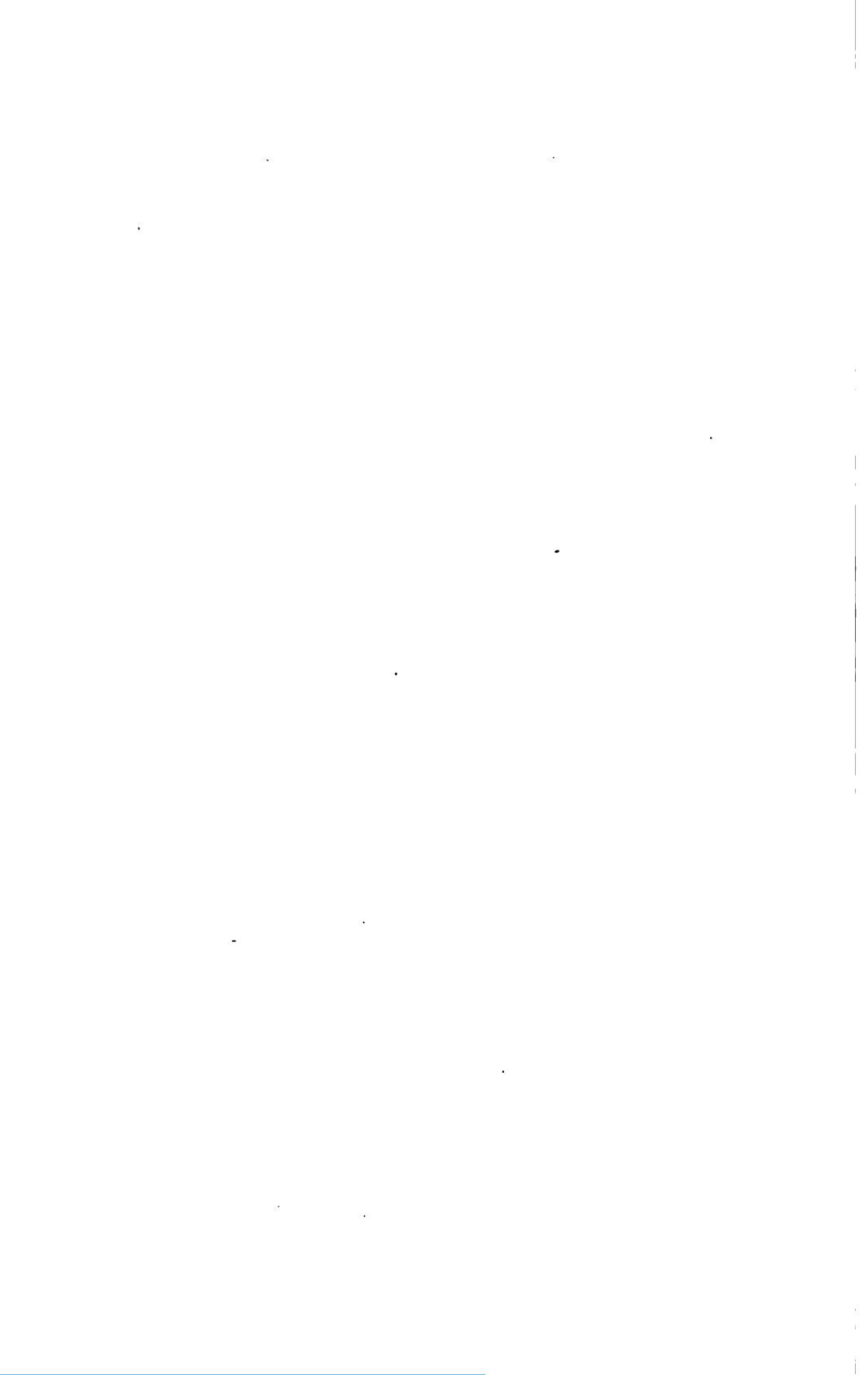

# THE DISTRIBUTION AND USE OF WATER IN MODESTO AND TURLOCK IRRIGATION DISTRICTS, CALIFORNIA.

By FRANK ADAMS, *Irrigation Assistant.*

## **PURPOSE OF REPORT AND CONDITIONS PROMPTING IT.**

California will some day be the home of many times its present population. This will be accomplished largely through the economic utilization of its 14,000,000 acres of valley agricultural land. Eleven million acres, or nearly 80 per cent of this total, is included in the great valley drained by the Sacramento and San Joaquin rivers and their tributaries. Over 2 per cent of the great valley, or a quarter of a million acres, is included in Modesto and Turlock irrigation districts, in the basin of the San Joaquin. If these two districts are to do their part in the making of the California of the future, they will have to maintain dense rural populations and supply food not only for many dwellers in California cities, but for many of those people outside of California who manufacture the goods California will import. This will require an agricultural awakening now hardly dreamed of by a majority of the people of these districts—an awakening that will cause an approach to the methods and results of old-world agriculture. Such an awakening recently began in the completion of Modesto and Turlock irrigation systems, for the turning of water into these systems marked the commencement of the change from the unprofitable one-crop dry farming of the past two decades to the more varied and more profitable agriculture under irrigation of the future.

The purpose of this report is to tell of the organization of Modesto and Turlock irrigation districts, and of the present agricultural and economic conditions in these districts, and to state the detailed results of a study of the distribution and use of water made in 1904 by the irrigation and drainage investigations of the United States Department of Agriculture, in cooperation with the State board of examiners of California and the University of California. The study had its inception in a resolution of the board of directors of Modesto irrigation district requesting the United States Department of Agriculture to make such investigation of the various questions relating to the use

and distribution of water in Modesto irrigation district as would assist in the establishment of proper rules and regulations for such use and distribution. After sixteen years of planning, endeavor, and disappointment, this district had so far met the problems of finance and construction as to be ready to deliver water to the farms of the district. The problems presented at this juncture, however, were new to the people of these districts. On the one hand was a canal ready to carry water; on the other were a hundred or more widely separated farms ready to receive it. How much water was it going to be necessary to deliver to each farmer for each acre of alfalfa or other crop irrigated? How often, and by what method, should this water be applied to the land? How much water was it going to be necessary to turn into the head of a 16-foot lateral to deliver the needed amount to 100 scattered acres at the lower end of this lateral? Should each irrigator receive his pro rata of the available supply as a continuous stream, or should he receive a larger volume for a shorter period? What administrative officers and employees were going to be needed in the work of delivery and how should they be organized so that each irrigator in the district, whether at the head of the first lateral or at the foot of the last one, should receive his share of the common supply with that certainty and promptness required for successful irrigation farming in a dry, hot climate? How far was it going to be necessary to restrict the choice of individual irrigators as to time and method of water delivery so as to give that uniformity of system without which no plan of delivery would be successful? In a word, how should the district proceed to make the best use of the water it had obtained at the cost, measured in money alone, of \$1,250,000?

In a way the questions presented to Modesto irrigation district were the questions presented to all new irrigation enterprises; yet, they were more difficult of answer and more far reaching in their application than new irrigation enterprises have generally had to meet. Here was a system that covered 80,000 acres of irrigable land, to which one great canal was to deliver water to farmers having no acquaintance with the requirements of irrigation farming, yet in which all were coowners with the right and obligation of jointly controlling and operating for their mutual benefit the water supply they had made available. On each of the 80,000 acres of land was a bond for its share of the million and a quarter dollars of indebtedness, and to each acre of land was attached, presumably inseparably, its share of the district water right. If the water supply should run short or the canal break, there was no ownership apart from the irrigators and their holdings to suffer from the resulting damage; and if the adopted system of distribution should prove unsatisfactory and inadequate, the irrigators alone would be responsible for devising a

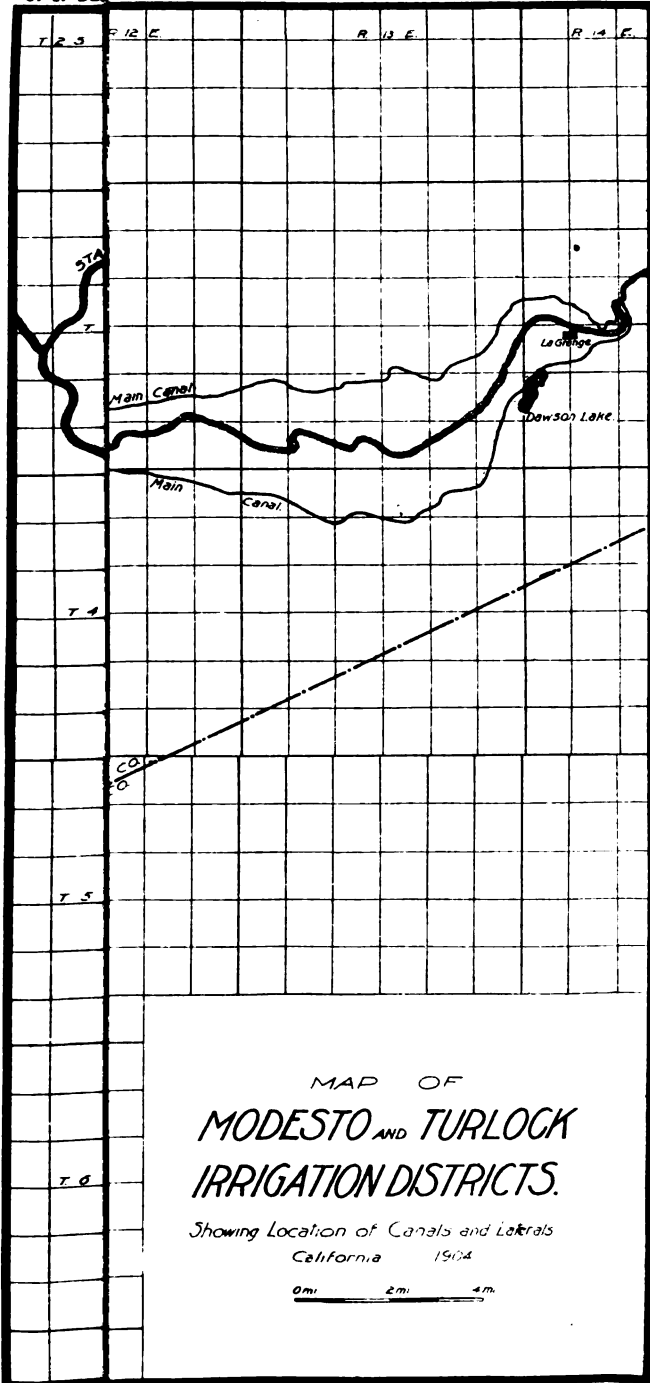

MAP OF  
 MODESTO AND TURLOCK  
 IRRIGATION DISTRICTS.

Showing Location of Canals and Levees  
 California 1914

0 mi. 2 mi. 4 mi.

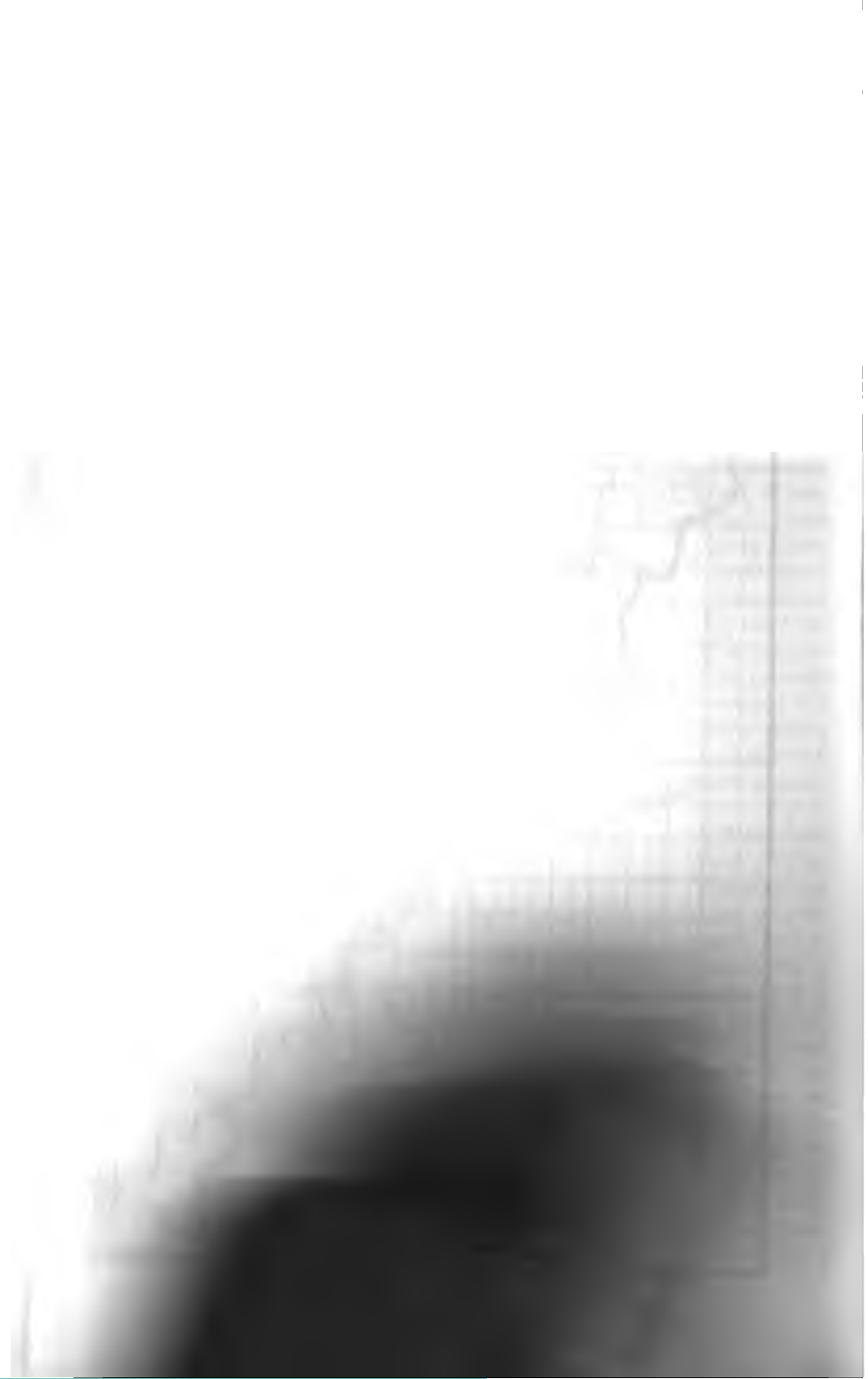

better one. Even more important, as showing the necessity for a just system of distribution, there was not an acre of land within the district that could escape its proportion of the annual tax for maintenance, operation, and betterment, regardless of whether water was applied or, if applied, regardless of the quantity used. The practical problems of use that met the district as a unit were therefore the problems that met the individual landholders and irrigators, important in proportion to the value of the land each held and difficult in proportion to the character and location of the holding. To ignore these problems, or even to fail in their solution, meant corresponding reduction in the ability of each landholder to get back from the land his proportion of not only that which had been put into the canal, but also of the taxes that would be levied for forty years to pay the principal and interest on the outstanding bonds.

Modesto irrigation district lies on the north side of Tuolumne River, east of the San Joaquin and south of the Stanislaus, and contains 81,143 acres (Pl. I). On the south side of the Tuolumne, principally in Stanislaus County, but also extending into Merced County, lies Turlock irrigation district, with 176,210 acres. By being jointly interested with Modesto irrigation district in diverting works from Tuolumne River above Lagrange, with conditions and needs practically the same and only the Tuolumne separating it, Turlock irrigation district is in many ways one in interest with Modesto district. The two were organized in the same summer and met substantially the same difficulties. In 1901, when Turlock canal was ready to carry water, the landholders in Turlock district faced the same problems of management and organization that came to Modesto district three years later. For this reason, and because it was believed the two districts will continue to have interests and difficulties in common, the study requested of the Department of Agriculture by Modesto district was made to include also Turlock district.

#### OUTLINE OF THE INVESTIGATION.

The investigation with which this report deals was begun the latter part of March, 1904, and continued until both Modesto and Turlock canals were closed for repairs and improvements in the fall. The subjects under consideration were as follows: (1) The organization and management of the districts; (2) the basis of their water rights; (3) the diversions from Tuolumne River in 1904 and their relation to the flow of the stream; (4) the area irrigated, the amount of water used in 1904, and the losses in transit by seepage and evaporation; (5) the crops grown and the methods followed in applying water; (6) the use of ground water, and (7) records and methods of water distribution.



**HISTORY OF MODESTO AND TURLOCK IRRIGATION DISTRICTS.****ORGANIZATION.**

The history of Modesto and Turlock irrigation districts properly begins with the failure of a quarter of a million acres of fertile valley land to yield a certain and rich harvest practically without cost and without work. Lying until the early sixties a vast, unfenced pasture of flowers, clover, and alfalfa, the land surrounded by Stanislaus, San Joaquin, and Merced rivers and the foothills of the Sierra Nevada, and bisected by the Tuolumne, had for a generation after farming began in the San Joaquin Valley been an agricultural El Dorado. Each season of plowing and seeding was sure to be followed by a bountiful yield, and this in turn was followed without further seeding by at least one and often two volunteer crops which, although reduced, were yet profitable. The people were happy and the towns prosperous. But the charm of this life broke. The time came when instead of two or three crops of grain or hay to one plowing, two and three plowings and an alternate season of summer fallow were necessary, or clearly would be necessary, to raise a single crop of the old proportions. With the failure of the soil came a fall in prices, the average value of a cental of choice wheat delivered at Modesto during the five years beginning in 1881 being \$1.45, as against \$1.63 for the five years preceding. Then the people commenced to talk about irrigation. While it is doubtful, judging from later results, if many anticipated irrigating grain, the progressive farmers were almost a unit in believing that water for raising green feed and fruit would be a blessing well worth striving for. Sentiment crystallized in favor of providing water from one of the ample streams of the neighborhood, but no satisfactory agreement could be reached as to the necessary details of such an undertaking, and no sufficient encouragement was offered for outside capital to work the problem out independently of the farmers.

In 1878 a law was passed creating an irrigation district, to be called the Modesto irrigation district, and to include the land lying between Tuolumne and Stanislaus rivers from San Joaquin River east to the foothills. A corporation was authorized to be formed for furnishing water to the district and the credit of the State and Stanislaus County was loaned for the payment of bonds up to \$500,000 in amount, covering the cost of canals and other irrigation works. Nothing substantial resulted from this law, but with it and other enactments as a basis, the author of the Wright law, himself a resident of the territory in question, in 1887 submitted to the legislature the draft of a law that proposed to enable neighborhoods in like condition with those around Modesto and Turlock to organize as public corporations and as such to raise money for supplying water for irrigation. The Wright law

was approved March 7, 1887, and before the middle of the following July Modesto and Turlock irrigation districts had been declared organized by the board of supervisors of Stanislaus County.

The legislature of 1897 enacted a new law for the organization and government of irrigation districts, at the same time repealing the Wright law and its supplementary and amendatory acts, so far as they might be inconsistent with the new act. This act, similar in its general features to the Wright law, was approved March 31, 1897, and is generally known as the irrigation act of 1897.

#### OPPOSITION TO THE DISTRICTS.

When the districts were organized, sentiment was not unanimous in their favor. Practically all wanted water, but, especially in Modesto district, there was determined opposition to irrigation under the Wright law or any other law that made a water lien general and forced taxes to be paid on land whether water was used on it or not. Land holdings varied in size from 160 to 2,000 or 3,000 acres, with probably more of 320 acres than of any other size. Many of those whose holdings were free from debt and who were satisfied to continue the old exclusive grain farming, and therefore did not want to sell, objected to paying water taxes on their entire holdings when they perhaps wanted to irrigate only 40 or 80 acres. In Modesto district this class represented about one-fifth of the area of the district and one-eighth of the assessed real property. To increase their effectiveness in their fight against the districts, they incorporated "defense" associations and used all possible means to defeat the incurring of debt and, when unsuccessful in that, to resist its payment. An action brought to confirm the organization and proceedings of Modesto district was contested and later carried to the United States Supreme Court. To further harass the districts the opposition landholders refused to pay their district taxes, and when their lands were offered for sale under the district law by the district tax collector, innumerable injunction suits were brought to prevent the sales. In 1897 the opposition elected a majority of the board of directors of Modesto district, and for four years blocked all assessments for interest due on the bonded indebtedness already incurred. Simultaneously with the attempts to defeat the existence of Modesto and Turlock districts, similar attempts were made in other districts organized under the Wright law, and just at the time construction on Modesto and Turlock canals, already several times delayed, was again getting under way, a decision was obtained in the United States circuit court for the southern district of California by the opponents of the districts, declaring the Wright law unconstitutional on the ground that it provided for the taking of private property without due process of law. At

this decision the money market refused to take more bonds and work had to be practically suspended until a final ruling could be obtained from the Supreme Court of the United States. This was obtained in the case of *Fallbrook Irrigation District v. Bradley et al.*, decided November 16, 1896, in which the law was declared constitutional and the ruling of the circuit court reversed.

Even with the law declared constitutional the opposition did not cease, and the final outcome of the enterprises was still uncertain. Land titles were so clouded that sales practically ceased, and thousands of acres of land that had once been considered worth \$30 and \$40 an acre were carried on the county and district assessment rolls at one-third of these values or less, with no sales at even these figures. Not only could no land be sold at figures approaching its value, but land that had begun to fail before the passage of the district law in 1887 was now even more difficult to cultivate profitably. Although in two or three years during the nineties wheat had brought a fair figure, in 1899, 1900, and 1901 it was back to the ruinous prices of the panic years of 1893 and 1894. Under these conditions, to continue the wasteful uncertainty that had characterized the existence of Modesto and Turlock districts for more than a decade would have been too great a burden for even those best prepared to meet it. A change for the better in the finances of the districts and in the attitude of the opposition was therefore inevitable. This change was gradual during the nineties, but perhaps was brought to a head in 1901, on the one hand by a sensible court decision upholding the integrity of the Turlock district bonds and on the other by a mandate from a United States court ordering Modesto district to levy an assessment for bond interest that had been defaulted since 1897. During this year each district reached an understanding with its bondholders, in Modesto district resulting in the bondholders and other creditors paying three-fourths of the sum necessary to complete the works, and in Turlock district resulting in a settlement with all creditors and bondholders on a basis of between 80 and 90 cents on the dollar. In both districts forty-year 5 per cent funding bonds were exchanged for the original twenty-year 6 per cent bonds, this exchange being effected under authority of a law passed in 1901. With these settlements and the new financial arrangements effected by them, opposition to the districts ended, and those who had been relentless against the districts came finally to be and are now among their staunchest supporters.

#### CONSTRUCTION.

Of the two districts, Turlock district, dating from June 6, 1887, was the first organized. The first engineer, Mr. George Manuel, estimated the cost of a system from Tuolumne River at \$467,544.62, and his plans were adopted, although later modified. In October, 1887, \$600,000 in

bonds was voted, the proceeds of which were to be used in construction, but it was not until 1890 that any contracts were let. In June, 1891, jointly with Modesto district, a contract was let for building the diverting dam above Lagrange, and this was completed in December, 1893. By May, 1892, it was apparent that sufficient funds had not been provided and an additional \$600,000 was voted. Two years later a bid was accepted for building the remainder of the system. This last bid, however, was accepted when the financial affairs of the district were at a low ebb, and in less than six months work under it was discontinued and the contract declared forfeited by the board of directors of the district. Later, on the representation of Judge James A. Waymire, this contract was revived, on condition that Waymire should proceed under it and render a completed system, fit for the conveyance and distribution of water, by April 1, 1896, at a total cost of not to exceed \$382,000. At the time of this agreement the money realized from the sale of \$708,000 worth of the \$1,200,000 in bonds voted had been spent. Owing to the difficulty of disposing of the bonds, due to the pending litigation over them, Waymire was unable to carry out his agreement within the time limit. In fact, the principal part of the work under the contract was done from 1897 to 1901.

On July 18, 1887, six weeks after the formation of Turlock irrigation district, Modesto irrigation district was organized. Three months later Mr. C. E. Grunsky, C. E., the engineer of the district, submitted three canal routes, one with Tuolumne River as the source of supply and a canal on the north side of the river; one with Stanislaus River as the source of supply; and one with Tuolumne River as the source of supply and a canal as far as Hickman on the south side of the Tuolumne jointly with Turlock irrigation district, the Modesto district's share of the water to be piped to the north side of the river from Hickman. A fourth plan submitted provided for part of the supply to be taken from the Stanislaus and part piped across the Tuolumne from a joint canal out of the Tuolumne carried on the south side of that stream as far as Hickman. The plan first adopted was the one having the Stanislaus as the source of supply, the estimated cost being \$644,750. The plan having the Tuolumne as the source of supply, with the canal wholly on the north side of the river, and estimated to cost \$1,117,860, found little favor at first, and the modification of this plan, submitted by Mr. Luther Wagoner, under which the canal was finally built, was not chosen until August, 1890. In November, 1887, shortly after the formation of the district, \$800,000 was estimated as the amount of money necessary for the works of the district, and this amount was voted in December, 1887. As the final canal route was not decided on until 1890, construction work was delayed and the first contracts were not let until the last of that year. By July 1, 1895, the joint diverting dam, the headworks, the flumes in

the upper 9,000 feet, and all the earthwork down to the east line of the district, a distance of about 22 miles, had been completed and accepted. At this time the first \$800,000 worth of bonds voted was gone, and although an additional \$350,000 was voted in July, 1895, none could be sold and construction work lapsed until 1902. In July, 1902, contracts were let for completing the works, and the construction called for by them was accepted October 6, 1903. The system purchased at a total cost of over \$1,250,000 was, after sixteen years of trying vicissitudes, finally ready to receive water.

#### LITIGATION.

Both Turlock and Modesto districts were in litigation almost from their organization down to 1901. The principal suits involved the constitutionality of the Wright law and the validity of the district bonds. In a decision in the suit of Turlock Irrigation District *v.* Williams, delivered May 31, 1888, and in numerous other suits the supreme court of California upheld the law, but it was not until November 16, 1896, when the United States Supreme Court decided the case of Fallbrook Irrigation District *v.* Bradley et al., already referred to, that a final ruling was reached on this point. The regularity of the proceedings of the districts, principally in reference to the issuance of bonds, was at stake in many suits, especially those involving the sale of land for delinquent taxes, but no decision was given establishing material defects in the proceedings. The last important suit of this nature, brought ostensibly to test the legality of certain district assessments levied to pay interest on bonds, was the case of Baldwin et al. *v.* The Board of Directors of Turlock Irrigation District et al., decided September 3, 1901. Although all bonds in both districts were nominally awarded to the highest bidders after due advertisement according to law, the actual sale of a large part of them was effected through the contractors, the contracts being let with the understanding that the contractors should either accept bonds for work or find a market for them. As the law provided that bonds should not be exchanged for work, the method of disposing of them adopted by the districts furnished ground for attack by those opposed to the district, but in the above-mentioned case the court found not only that there was no material irregularity in the issuance of the bonds, but that those in possession of them at the time of the decision had come into possession without any knowledge of the alleged irregularity, and that therefore the bonds were valid. This suit is interesting as being the one that finally demonstrated to the people of Turlock irrigation district in clear terms their obligation to the bondholders.

The trying financial difficulties of Turlock and Modesto districts, which seriously menaced their existence for the first fourteen years

after their organization, furnish in their own way an example of what has had to be overcome in legitimate irrigation organization. After the lapse of seventeen years there is not apparent any glaring unwisdom in the organization and management of these districts during the period of construction. A criticism that some have urged against the management is that many of the contracts were let at too high a figure, yet it is a fact that some of the largest holders of contracts lost heavily, because they were charged with the necessity and the responsibility of selling district bonds on a market that would not receive them at a profitable figure.<sup>a</sup> It is true that official records have not in every case been kept with the accuracy and precision contemplated by law, yet districts to be organized in the future are to be warned against duplicating these omissions more than Modesto and Turlock districts are to be condemned for them. There never was a time when the real property of the districts was not worth far more than the amount of their bonded indebtedness, yet for four years in Turlock district and for seven years in Modesto district the work of construction was suspended because the bonds of the districts could not be sold. If the people of these districts had foreseen the financial stress of the early nineties and the flood of general litigation over the Wright law that was to be precipitated from causes largely, if not wholly, outside of Modesto and Turlock districts, they undoubtedly would not have made the almost fatal mistake of organizing in the face of the opposition that was both extensive and bitter from the start. That they were able to overcome difficulties in spite of mistakes was due to the great latent resources of the territory the districts comprised, because it was inevitable that so favored an area should be put to a higher and more economical use than dry farming could ever make possible.

The districts are to-day, without doubt, financially sound, and although their securities are not active they are either already worth par or give promise of soon becoming so. Between 35 and 40 per cent of all of the bonds issued thus far in the districts are held by the owners of real property or by residents in one or the other of the districts. On March 1, 1904, the total outstanding indebtedness of Modesto district was \$1,388,511, or \$17.10 for each of the 81,143 acres in the district. Substantially one-fourth of the district taxes are paid in the city of Modesto, leaving an average indebtedness for the farming land of approximately \$12 per acre. On May 1, 1904, the total indebtedness of Turlock district was \$1,130,400, or an average of \$6.41

---

<sup>a</sup> During the dark days of the districts the bonds were down to 45 with practically no sales at that figure. Unpaid interest coupons of Modesto district were seeking buyers at 30 per cent of their face value and without finding them until about six months before the agreement was reached with the bondholders by which the original bonds were funded. At this time many of these unpaid coupons were bought up by delinquent taxpayers and turned over to the district in settlement of delinquent taxes.

for each of the 176,210 acres in the district. On September 10 of the same year \$200,000 of additional bonds was voted for making permanent improvements in the canal system, of which \$75,000 worth have been sold at par, entirely to people within the district, increasing the average indebtedness per acre only about 40 cents. The annual assessments in both districts have varied with the assessment rolls. In 1904 the assessed valuation of Modesto district was \$4,342,125 and the tax levy \$2.60 for each \$100, of which \$1.55 was for bond interest and \$1.05 for construction, maintenance, and operation. This required a tax of approximately \$1 per acre on the farming land. In Turlock district the assessment roll gave a total of \$2,993,538, and the tax levy was \$3.30 for each \$100, of which \$2.20 was for bond interest and \$1.10 was for maintenance and operation. This required a tax averaging \$0.56 per acre on the land in the district.

### WATER RIGHTS.

Modesto and Turlock districts base their rights to water from Tuolumne River on (1) deeds from M. A. Wheaton, dated August 11, 1890, and August 15, 1890, conveying to Modesto district, and to Modesto and Turlock districts jointly, certain land and water rights incident to the old Wheaton dam and ditch; (2) notices of appropriation posted, respectively, by Modesto and Turlock districts on June 21, 1890, and on January 5, 1889, and claiming, respectively, 250,000 and 225,000 miner's inches measured under a 4-inch pressure, and (3) the diversion and use of water since the building of the two canals. Also, it is probable that should any litigation arise over their water rights, the districts would allege riparian proprietorship and riparian rights. The deeds from Wheaton did not convey any definite amount of water, but "the first and original water right under which water was first diverted from the said Tuolumne River" by means of the old Wheaton dam, which was located on the site of the present joint dam, and "all water and water rights, if any, he has upon or appurtenant to" certain lands at the site of the old Wheaton dam. The original filing, under which Wheaton claimed, was that of the Franklin Water Company, organized November 30, 1854. On December 6, 1854, the French Bar Water Company was organized, also to divert water from the Tuolumne. November 27, 1855, the Stanislaus Water Company organized and succeeded to the rights of the Franklin Water Company and of the French Bar Water Company, and on May 28, 1862, these "rights" came into possession of one Elam Dye, who shared their ownership with two partners, John Bixby and John Reedy, the last named getting full possession by deeds of March 27, 1867, and May 7, 1868. September 6 and 16, 1870, Reedy deeded the property to Michael Kelly, who posted a new notice of appropriation May 1, 1871, and, June 26, 1871,

deeded his "entire right, title, and interest in the Tuolumne River and all its privileges of water and otherwise" to J. M. Thompson, Charles Elliott, and M. A. Wheaton. By various deeds of August 26, 1871, November 8, 1871, July 30, 1872, January 27, 1873, and December 31, 1873, the property came into the full possession of Wheaton, including any rights that may have been acquired by Wheaton and others through a notice of appropriation of 500,000 miner's inches under a 4-inch pressure posted May 18, 1872. The notices of appropriation filed June 21, 1890, and January 5, 1889, by Modesto and Turlock districts, respectively, were in the usual form and were the last of a number of such notices posted prior to these dates and after the districts were organized in 1887.

The extent of the use of water since the construction of the canals is shown elsewhere in this report. This use and the ability of the districts to divert and beneficially apply water in the future are probably the chief measures of the rights as they exist to-day. Neither district will ever be able to either divert or beneficially use the full volumes called for in their appropriation filings. Modesto district claimed 250,000 miner's inches measured under a 4-inch pressure, or 5,000 cubic feet per second, and Turlock district claimed 225,000 miner's inches measured under a 4-inch pressure, or 4,500 cubic feet per second. As planned Modesto canal was calculated to carry 640 cubic feet per second and Turlock canal 1,500 cubic feet per second, but up to the end of the season of 1904 the maximum diversion by the former was 278 cubic feet per second and by the latter 535 cubic feet per second. However, both canals are now being enlarged, and further enlargements will doubtless be made as the area ready to receive water in the districts is increased. Whether, during the years construction was suspended, the districts used due diligence in carrying out the purpose stated in their appropriation filing, will never assume any importance, because no adverse claims to the Tuolumne arose during that time. Without doubt the proper diligence has been exercised since 1901 and will be in the future. The only adverse claim that has arisen since 1901 is that of the Merced Gold Mining Company, which owns a small ditch in the mountains near Hamilton Station, built some twenty years ago, but abandoned and used again only during the last few years. October 6, 1903, an injunction suit against this ditch was filed by Modesto district in the superior court of Tuolumne County, but this was intended chiefly to forestall the possible acquirement of a prescriptive right and has not been pressed.

Assuming that so far as concerns the public the districts have a clear title to so much water as they will be able to beneficially apply, the relative rights of the two districts are presumably fixed by an agreement entered into by the districts August 9, 1890, providing for the



construction of the joint dam at Lagrange. The portions of this contract relating to water rights are given herewith:

All water diverted by means of said dam shall be divided and distributed between said districts in proportion to the number of acres in the respective districts.

It is further understood and agreed that in case either district shall acquire any additional water rights, privileges, or rights in stored water above said dam, the other district shall have the privilege of sharing in such property by paying therefor within sixty days after written notice of the intention to purchase, or the acquisition of such property, its proportional part of the cost and expense thereof, said cost and the water so acquired to be divided in proportion to the number of acres embraced in the respective districts.

As the area of Modesto district (81,143 acres) is roughly one-half that of Turlock district (176,210 acres) the water is at present divided between them at the rate of 2 cubic feet per second to Turlock district for each cubic foot per second diverted by Modesto district. When the districts become more fully developed an effort will probably be made to carry out the exact terms of the contract.

There is one ditch on Tuolumne River—that of the Lagrange ditch and Hydraulic Mining Company—holding an earlier water right than either Modesto or Turlock canals. This ditch heads in the canyon some 10 miles above Lagrange dam and follows the south bank of the Tuolumne to the vicinity of Lagrange dam, where it makes a detour to the south and west, supplying water to the town of Lagrange and to mining properties held by its owners. This ditch has a claimed capacity of 100 cubic feet per second, but it has carried under 50 cubic feet per second, when in operation, during the past few years.

#### **MODESTO AND TURLOCK CANALS.**

The diverting works and canals of Modesto and Turlock districts are of modern type and for the most part substantially constructed. Lagrange dam, by which water is diverted into both canals, is recognized by engineers as a well-designed and well-built structure, and at the time of its completion, December, 1893, had the distinction of being the highest overflow dam in the United States. It is built of uncoursed rubble masonry laid in cement concrete, cost \$550,000, and is located in the channel of Tuolumne River,  $1\frac{1}{2}$  miles above Lagrange.

Modesto canal leaves the Tuolumne on the right bank of the river at the north end of the dam, and Turlock canal heads directly opposite, just above the south end, for the first 600 feet tunneling through solid rock. For the first 5 miles both canals pass through rough foothill country, where heavy construction was encountered, and after that follow the open foothills until the main plain of San Joaquin Valley is reached, 15 miles west of Lagrange. Below this, and for the rest of their lengths, both canals and their branches or laterals follow the more even slopes of the valley, in some cases



FIG. 1.—A 15-FOOT CONCRETE DROP ON MODESTO CANAL.



FIG. 2.—SECTION OF TURLOCK CANAL, SHOWING CONCRETE LINING OF LOWER WALL.



departing but little if any from the general section lines. Modesto canal enters Modesto district 3 miles west of Waterford and 20 miles west of Lagrange dam. Below this point it follows a general north-westerly direction, the laterals, eight in all, leading to the west and covering the various parts of the district. Turlock canal enters Turlock district 4 miles east of Hickman, a small town on the south side of the Tuolumne,  $1\frac{1}{2}$  miles south of Waterford. One mile southwest of Hickman it branches into Turlock main, which runs south to within 5 miles of Merced River, and feeds laterals 2, 3, 4, 5, 6, and 7, and Ceres main, which continues west to within  $1\frac{1}{2}$  miles of Ceres, where it turns south, crossing lateral 2 and extending to lateral 3. Modesto canal has a length of 45 miles and the eight laterals an aggregate length of 81 miles. The upper portion of the main canal varies in width from 18 to 44 feet and in grade from 1 foot in 5,000 feet, where the bottom width is 44 feet, to  $7\frac{1}{2}$  feet and 9 feet in 5,000, where the bottom width is 18 feet. The laterals are 12 and 14 feet wide and 1.8 feet deep, and vary in grade from 1.8 feet to 3 feet in 5,000, according to the width. Turlock canal, from Lagrange dam to the division below Hickman, has a length of 23 miles. The length of Turlock main is 11 miles and of Ceres main 14 miles. The aggregate length of the eight laterals is 85 miles. Above the division point below Hickman the main canal varies in bottom width from 20 feet near the head to 70 feet through the lower foothill region and the plains. The grade varies from 1 foot to 8 or 9 feet per mile. The two main branches below Hickman are from 30 to 40 feet wide, and vary in grade from 1.58 feet to 3.16 feet per mile. The laterals begin with bottom widths of 20 feet and diminish to 12 feet, and the grades average 2.5 feet per mile.

The financial difficulties encountered by Modesto and Turlock districts during the periods of construction compelled in some cases the use of temporary structures. It is the policy of the districts to replace these from time to time by permanent works, so that interruptions in the canal flow and expenses of maintenance shall be reduced to a minimum. This installation of permanent structures has already begun in both districts. Both canals have a large number of timber drops and also considerable lengths of wooden flumes—8,932 linear feet in 13 structures on Modesto canal, and 2,800 linear feet in 5 structures on Turlock canal. Modesto district has already installed two concrete drops instead of timber structures (Pl. II, fig. 1) and is preparing to replace in the next few years 2,950 feet of wooden flume, beginning at the regulating gate, near Lagrange dam, with an all-concrete channel. About 4,000 feet of the channel has already been lined wholly or in part with concrete, and a substantial concrete conduit 60 feet long and 40 feet wide has been placed over Litts Creek, a small stream well down in the district. All of the flume work on Modesto canal

below the 2,950 feet at the head is substantially built and will last for many years. It is supported chiefly by standard railroad bents resting on concrete piers. The longest of the high flumes—that over Dry Creek, which contains 1,000 linear feet—rests partly on a steel span. Long stretches in the upper 2 miles of both Modesto and Turlock canals were originally built with the lower wall of clay puddle between hand-laid slate-rock walls. These did not prove satisfactory, owing to the decomposition of the slate rock, and it has been necessary to line these sections with concrete. The concrete lining on Modesto canal, already mentioned, was largely built to replace such a wall. Turlock district has lined the outside wall of its canal in this way for the first 4,800 feet of its length (Pl. II, fig. 2). It now contemplates even more costly permanent improvements by replacing 300 feet of high wooden flume over Morgan Gulch, one-half mile below Lagrange dam, by three lines of 6-foot inverted steel siphon, solidly embedded at each end in concrete masonry, or by a flume carried on a steel span. It is now replacing 1,540 feet of troublesome low wooden flume through Snake Ravine, 1 mile below Lagrange dam, by a canal section shelved into the sidehill, with a concrete retaining wall on the lower side. The cost of these two improvements will approximate \$47,000. Improvements costing \$11,000 are also being made in a high wooden flume across Delaney Gulch, 5 miles below Lagrange dam. The inverted steel siphons across Morgan Gulch will be an innovation in these districts, and if they are adopted and prove satisfactory several of the other ravines in the system will be crossed in the same way. The plans for these structures, designed by Mr. S. Fortier, C. E., provide for five lines of pipe, having a total capacity of 1,500 cubic feet per second, but only three lines will be installed at the start, these three lines to cost \$21,000.

The diverting and regulating works of both Modesto and Turlock districts are thoroughly well built, and are of a permanent character. Lagrange dam, already mentioned, was designed principally by Mr. Luther Wagoner, C. E., at one time engineer for Modesto district, and constructed chiefly under the supervision of Mr. E. H. Barton, C. E., at one time engineer for Turlock district. The principal structures on Modesto canal, including head gates, sluice gates, regulating gates, flumes, and drops, were designed by Mr. Otto von Geldern, C. E., and installed under the direction of Mr. Milo Hoadley and Mr. H. S. Crowe. The latter, at present engineer and superintendent of the district, also laid out and constructed the main canal and its branches within the district. In addition to Mr. E. H. Barton, engineer for Turlock district during the construction of Lagrange dam, those principally in charge of designing and constructing Turlock canal and regulating works were Mr. George Manuel, C. E., and Mr. R. H. Goodwin, C. E.

Turlock canal was originally planned to carry 1,500 cubic feet per second, and Modesto canal was planned to carry 640 cubic feet per second. The largest amount yet carried by the former is 535 cubic feet per second, carried in 1904, and by the latter 278 cubic feet per second, also run in 1904. The improvements now contemplated or being made in Turlock canal will increase its capacity in the improved sections to 900 cubic feet per second—1,500 cubic feet per second through Snake Ravine—but it is probable that not more than 600 cubic feet per second will be run until after Peaslee flume, now crossing Peaslee Gulch on high trestles, is replaced by a new flume or inverted steel siphons. The latter are estimated to cost \$24,500, if a capacity of 900 cubic feet per second is provided, or \$39,000 if a capacity of 1,500 cubic feet per second is provided. This improvement is planned for 1905. With the improvements now in progress completed, Modesto canal is expected to carry 500 cubic feet per second.

**RAINFALL.**

No records of precipitation are kept in Modesto or Turlock districts by the Weather Bureau and consequently no complete rainfall data are available. The Southern Pacific Company and several individuals have kept records which, although fairly complete, differ some from each other. One of the most complete records has been kept by the Grange Company at Modesto, and a copy of this from 1889 through 1904 is inserted below. The average annual rainfall is seen to be 12.10 inches, falling principally from October to April, both inclusive. The precipitation during the five months from May to September is in every case small, although in some years a quite heavy fall has occurred in one of these months. For all practical purposes, however, the principal growing and harvesting season is largely devoid of precipitation, and for any annual crops other than those planted in the fall irrigation is necessary.

*Annual and monthly rainfall at Modesto, Cal., 1889-1904.*

[Furnished by the Grange Company.]

Year.	Jan.	Feb.	Mar.	Apr.	May.	June.	July	Aug	Sept	Oct.	Nov.	Dec.	Total.
	<i>In</i>	<i>In</i>	<i>In</i>	<i>In</i>	<i>In</i>	<i>In</i>	<i>In</i>	<i>In</i>	<i>In</i>	<i>In</i>	<i>In</i>	<i>In</i>	<i>In</i>
1889.....	0.28	0.38	2.22	0.22	1.39	0.00	0.00	0.00	0.00	2.49	3.51	6.76	17.28
1890.....	3.76	1.40	.23	1.48	.59	.00	.00	1.29	.00	.00	.00	2.18	10.93
1891.....	.27	2.66	1.03	1.10	.00	.00	.00	.38	.00	.12	4.06		9.62
1892.....	1.63	1.77	2.21	.57	1.09	.04	.00	.00	.01	.89	3.70	2.20	14.11
1893.....	1.71	1.83	3.38	.54	.21	.00	.00	.00	.10	.00	1.04	1.34	10.15
1894.....	3.61	3.40	.09	.23	1.76	.57	.00	.00	.00	1.73	.32	6.25	17.96
1895.....	3.80	1.41	1.68	1.07	.35	.00	.00	.00	.17	.07	.93	1.02	10.50
1896.....	5.16	.07	.78	2.08	.29	.00	.30	.02	.25	1.32	2.45	1.23	13.95
1897.....	3.16	2.77	1.86	.14	.09	.02	.00	.00	.00	.97	.18	1.17	10.36
1898.....	.51	.69	.31	4.07	.67	.00	.00	.00	.28	.48	.33	2.22	9.56
1899.....	2.36	.12	3.75	.04	.94	.00	.00	.00	.00	1.89	2.88	1.29	13.27
1900.....	1.31	.15	.88	1.93	1.47	.00	.00	.00	.14	.71	4.62	1.03	12.24
1901.....	1.31	3.90	.34	.84	1.24	.00	.00	.00	.05	.66	1.58	.65	10.57
1902.....	.73	4.46	.65	.72	.34	.00	.00	.00	.00	.41	1.54	.59	9.44
1903.....	2.19	.89	6.08	.36	.00	.00	.00	.00	.00	.00	2.45	.17	12.14
1904.....	.52	1.84	2.46	1.39	.09	.00	.00	.13	2.57	.95	1.01	.64	11.60
Average.....	2.01	1.73	1.75	1.05	.66	.04	.02	.01	.32	.79	1.67	2.05	12.10

### DIVERSIONS FROM TUOLUMNE RIVER IN 1904 BY MODESTO AND TURLOCK CANALS.

In 1904, except when closed for repairs, both Modesto and Turlock canals carried water from January until late in the fall, Modesto canal being closed for the season September 30, and Turlock canal running until October 20. For the 274 days from January 1 to September 30, Modesto canal carried a mean flow of 167 cubic feet per second; for the 275 days from January 20 to October 20 Turlock canal diverted a mean flow of 305.9 cubic feet per second. The greatest amount carried at any time by Modesto canal was 278 cubic feet per second, and the greatest amount carried at any time by Turlock canal was 535 cubic feet per second. The tables below show the amounts diverted each day of the season, and also the mean flow for each month in each canal, the records having been taken at the irrigation and drainage investigations' gauging stations near the head gates.<sup>a</sup> In computing the average monthly flow the full number of days in the month was used.

*Diversions from Tuolumne River by Modesto canal, January 1 to September 30, 1904.*

Day.	Jan.	Feb.	Mar.	Apr.	May.	June.	July.	Aug.	Sept.
	<i>Cu. ft. per sec.</i>	<i>Cu. ft. per sec.</i>	<i>Cu. ft. per sec.</i>	<i>Cu. ft. per sec.</i>	<i>Cu. ft. per sec.</i>	<i>Cu. ft. per sec.</i>	<i>Cu. ft. per sec.</i>	<i>Cu. ft. per sec.</i>	<i>Cu. ft. per sec.</i>
1.....	178	152	22	24	150	218	266	245	106
2.....	178	152	38	152	165	223	261	251	101
3.....	176	152	82	160	229	234	266	251	80
4.....	176	152	93	150	223	229	266	245	80
5.....	176	192	93	181	223	234	273	245	72
6.....	176	194	93	170	223	234	278	240	72
7.....	176	194	127	165	234	234	278	245	62
8.....	178	194	127	70	234	145	266	245	60
9.....	178	191	127	160	180	127	266	240	57
10.....	178	191	82	181	170	207	266	240	53
11.....	178	191	82	191	140	246	261	240	45
12.....	181	200	115	194	170	256	266	234	45
13.....	178	54	152	181	234	251	261	223	45
14.....	178	.....	152	191	234	251	256	202	45
15.....	178	.....	152	181	234	256	256	229	42
16.....	178	.....	152	165	234	256	261	261	42
17.....	178	.....	152	181	234	256	261	261	71
18.....	178	.....	165	160	234	261	266	251	76
19.....	178	.....	165	101	229	261	266	256	72
20.....	178	.....	165	120	196	261	261	240	68
21.....	176	.....	165	202	92	261	261	197	60
22.....	176	.....	191	65	16	261	251	181	53
23.....	176	.....	191	115	67	261	39	155	60
24.....	191	6	191	218	70	261	.....	145	121
25.....	194	11	197	223	110	261	.....	145	135
26.....	196	16	180	218	165	266	170	145	131
27.....	194	17	180	212	207	266	245	150	131
28.....	192	17	55	191	229	261	238	148	131
29.....	152	18	49	130	234	266	234	105	140
30.....	152	.....	191	130	234	266	234	135	75
31.....	152	.....	191	.....	234	.....	240	120	.....
Average.....	178	79	133	159	196	242	233	209	78

<sup>a</sup> Records from January 1 to April 1 furnished by Mr. S. G. Bennett, hydrographer, U. S. Geological Survey.

*Diversions from Tuolumne River by Turlock canal, January 20 to October 20, 1904.*

Day.	Jan.	Feb.	Mar.	Apr.	May.	June.	July.	Aug.	Sept.	Oct.
	<i>Cu. ft. per sec.</i>	<i>Cu. ft. per sec.</i>	<i>Cu. ft. per sec.</i>	<i>Cu. ft. per sec.</i>	<i>Cu. ft. per sec.</i>	<i>Cu. ft. per sec.</i>	<i>Cu. ft. per sec.</i>	<i>Cu. ft. per sec.</i>	<i>Cu. ft. per sec.</i>	<i>Cu. ft. per sec.</i>
1		111	380	348	470	511		505	248	441
2		228	380	396	462	503	150	409	150	441
3		225	380	412	470	519	312	465	183	441
4		286	388	412	478	511	449	465	150	441
5		286	388	429	486	519	497	465	167	441
6		286	388	412	478	527	521	465	150	441
7		286	388	429	486	527	505	473	186	441
8		286		429	294	513	513	473	122	441
9		286		446	420	527	505	473	122	441
10		286		348	462	513	513	473	109	328
11		286		446	486	402	513	473	97	377
12		252		454	495		505	473	97	441
13		315	77	462	495		473	473	97	441
14		332	218	462	503		473	401	97	441
15		272	272	462	519		489	401	91	441
16		308	93	462	519		489	393	91	441
17		348		462	519		505	393	116	425
18		348		462	519			473	143	312
19		348		396	519			473	143	264
20		205	348	462	519			473	158	183
21		205	348	462	511			457	136	
22		83	348	462	519			377	109	
23		83	348	462	503			312	109	
24		83	279	462	511		15	296	296	
25		83	308	478	511		232	288	433	
26		123	141	462	511		377	288	76	
27		238	191	470	511		385	264	441	
28		218	380	462	511		497	288	441	
29		238	380	470	527		505	288	441	
30		238		470	519		521	312	441	
31		225	205	511	511		505	248		
Average	169	289	115	441	491	169	377	404	186	402

Modesto canal first carried water late in the fall of 1903. Turlock canal commenced running a supply for irrigation in 1901, during which season an average of about 200 cubic feet per second was run in the irrigating months. As high as 400 cubic feet per second was carried in 1902 and a somewhat larger amount was run in 1903.

Records of flow of Tuolumne River at Lagrange have been kept since 1896 by the United States Geological Survey, and from these records the average monthly flow has been computed for seven years. These averages, and the records from which they were computed, are given below:<sup>a</sup>

*Mean monthly flow of Tuolumne River at Lagrange for the seven years, 1896 to 1902.*

Month.	1896.	1897.	1898.	1899.	1900.	1901.	1902.	Average.
	<i>Cu. ft. per sec.</i>	<i>Cu. ft. per sec.</i>	<i>Cu. ft. per sec.</i>	<i>Cu. ft. per sec.</i>	<i>Cu. ft. per sec.</i>	<i>Cu. ft. per sec.</i>	<i>Cu. ft. per sec.</i>	<i>Cu. ft. per sec.</i>
January	2,344	1,231	478	511	2,408	3,361	352	1,526
February	1,196	5,172	924	764	1,053	7,214	1,443	2,538
March	2,757	4,032	1,248	3,630	2,451	3,730	2,290	2,877
April	3,554	7,735	4,065	5,217	2,403	3,968	5,003	4,564
May	4,461	11,923	4,644	4,537	6,943	8,043	6,659	6,744
June	7,724	5,673	2,271	6,684	5,386	9,394	6,925	6,294
July	3,035	2,181	301	1,045	826	3,708	1,403	1,786
August	3,617	2,237	109	224	112	784	378	337
September	464	86	44	76	49	175	89	140
October	152	222	76	536	1,240	211	113	364
November	1,167	768	63	2,453	2,546	574	676	1,178
December	1,115	1,104	280	3,071	1,342	1,339	809	1,294

<sup>a</sup> These records include the amounts diverted by Turlock canal and Lagrange ditch.



The table shows that the largest flow of the river occurs in April, May, and June, the months when the largest supply for irrigation is needed; also that the supply is very short in August, September, and October.

For the more ready comparison of the diversions by Modesto and Turlock canals in 1904 with the normal flow of the river the summary given below has been prepared. This summary shows that in 1904, except in August, September, and October, the combined diversions by the two canals did not approach the river flow, and that from January 1 to October 31 they were but 15.8 per cent of that amount. The opportunities for storage are therefore large. In August and September, 1904, the river was raised by somewhat unusually early rains, and the diversions during these months were more than the normal stream flow—181.4 per cent of that normal in August and 189 per cent of it in September.

*Comparison of total diversions from Tuolumne River in 1904 by Modesto and Turlock canals with the average flow of Tuolumne River for seven years, 1896 to 1902.*

Month.	Mean flow Tuolumne River, 1896 to 1902.	Combined flow Modesto and Turlock canals Jan. 1 to Oct. 20, 1904.	Percentage diverted by canals.
	<i>Acre-feet.</i>	<i>Acre-feet.</i>	<i>Acre-feet.</i>
January .....	93, 831	14, 927	14. 8
February .....	141, 673	21, 201	15. 0
March .....	176, 961	15, 221	8. 6
April .....	271, 577	35, 733	13. 2
May .....	414, 672	41, 679	10. 1
June .....	374, 519	24, 497	6. 5
July .....	109, 817	35, 031	31. 9
August .....	20, 721	37, 645	181. 7
September .....	8, 331	15, 746	189. 0
October .....	22, 381	15, 960	71. 3
November .....	70, 086		
December .....	79, 565		
Year .....	1, 784, 144	257, 640	14. 4

If the flow to October 31 only is considered, 15.6 per cent is the relation of diversions to the discharge of the stream.

This summary shows that in 1904, except in August, September, and October, the combined diversions by the two canals did not approach the river flow, and that for the year the diversions were only 14.4 per cent of the amount carried by the river. In August and September the river was raised by early rains, and the diversions during these months were more than the normal stream flow. Water failed to spill over Lagrange dam only from August 12 to September 24, and after the latter date there was a large surplus.

**THE WATER USED IN 1904.**

On October 22, 1887, in recommending canal routes to Modesto irrigation district, Mr. C. E. Grunsky, C. E., estimated that enough water would be necessary each year in Modesto district to cover the land in the district to an average depth of 2 feet and 8 inches. In reaching this conclusion it was estimated that the irrigating duty of 1 cubic foot of water per second would be 160 acres from March to June, 400 acres from July to September, 640 acres from October to December, and 1,280 acres in January and February. While it is undoubtedly true that eventually the covering of land in Modesto and Turlock districts to a depth of 2 feet and 8 inches each year will be ample for the ordinary crops under average conditions, it is interesting to compare the amount of water used in 1904 with Mr. Grunsky's original figures. To be able to determine the amounts used in 1904 gauging stations were maintained by the irrigation and drainage investigations in both Modesto and Turlock canals short distances below Lagrange dam; also on each canal near its entrance into the districts 20 miles below, and on lateral 1 of the Modesto canal and lateral 3 of Turlock canal.

The amounts of water diverted by each canal have already been given in detail (pp. 108, 109). Expressed in acre-feet, by months, these amounts are repeated in the summary below. It will be noted that Modesto canal diverted a little more than one-half as much as was diverted by Turlock canal.

*Total and monthly diversions from Tuolumne River above Lagrange by Modesto and Turlock canals from January 1 to October 20, 1904.*

Month.	Modesto canal.	Turlock canal.	Month.	Modesto canal.	Turlock canal.
	<i>Acre-feet.</i>	<i>Acre-feet.</i>		<i>Acre-feet.</i>	<i>Acre-feet.</i>
January .....	10,917	4,010	July .....	14,306	20,725
February .....	4,550	16,651	August .....	12,833	24,812
March .....	8,166	7,055	September .....	4,659	11,087
April .....	9,485	26,248	October .....		15,960
May .....	11,460	30,219	Season .....	90,795	166,845
June .....	14,419	10,078			

From Lagrange dam both canals—Modesto on the north bank of the Tuolumne and Turlock on the south bank—pass through some 20 miles of more or less rough foothill country before reaching the land embraced in the irrigation districts. While the diversions from the Tuolumne at Lagrange show the gross service of the water diverted, records kept at Waterford and Hickman, near the entrance of the canals into the districts, indicate the amounts delivered to the districts. These records are summarized on page 112. For January, February, and March the amounts are computed from the flow at Lagrange.

*Flow of Modesto and Turlock canals near Waterford and Hickman, respectively, during season of 1904.*

Month.	Modesto canal at Waterford.	Turlock canal at Hickman.	Month.	Modesto canal at Waterford.	Turlock canal at Hickman.
	<i>Acre-feet.</i>	<i>Acre-feet.</i>		<i>Acre-feet.</i>	<i>Acre-feet.</i>
January .....	9,084	3,200	July .....	12,477	15,480
February .....	3,777	13,221	August .....	11,724	20,142
March .....	6,779	5,644	September .....	4,146	8,347
April .....	7,823	21,300	October .....		13,500
May .....	8,705	25,219	Season .....	76,717	136,753
June .....	12,202	10,700			

These two summaries, taken in connection with the areas irrigated, show the service of water in Modesto and Turlock districts in 1904. In Modesto district 6,895 acres were watered and in Turlock district the area supplied was 20,000 acres. The total diversions by Modesto canal amounted to 90,795 acre-feet, or enough to cover the area irrigated to a depth of 13.18 feet. The total amount reaching the district line near Waterford was 76,717 acre-feet, or enough to cover the 6,895 acres to a depth of 11.13 feet. The total diversions by Turlock canal amounted to 166,845 acre-feet, or enough to cover the 20,000 acres irrigated to a depth of 8.34 feet. Of this, 136,753 acre-feet reached Hickman, which was enough to cover the 20,000 acres to a depth of 6.84 feet. Expressed differently, each cubic foot per second diverted by Modesto canal served 41.29 acres, and each cubic foot per second diverted by Turlock canal served 65.38 acres, both of these areas being estimated from the mean flow for each canal given on page 110, the season being computed as extending in the Modesto district from January 1 to September 30, and in the Turlock district from January 20 to October 20, inclusive.

The above figures are more valuable for stating the service of water in 1904 than they are for showing the amount of water necessary for the crops grown. Wasteful use was more often the rule than the exception. Besides, much of the water applied prior to April and during the last three weeks run in each district was put on new checks for the purpose of settling the ground before seeding. Also, portions of the year, especially prior to April 15, some water was allowed to waste at the lower end of some of the laterals. Much water was also lost by seepage through the sandy bottoms of the laterals, and there were losses in the main canals below the point of daily record. Records kept on lateral 1 in Modesto district and lateral 3 in Turlock district show more nearly the amounts of water applied to land in 1904. These amounts are expressed in acre-feet, by months, in the summary following.

Summary of amounts of water run in lateral 1 Modesto district and lateral 3 Turlock district during season of 1904.

Month.	Modesto district, lateral 1.	Turlock district, lateral 3.	Month.	Modesto district, lateral 1.	Turlock district, lateral 3.
	<i>Acre-feet.</i>	<i>Acre-feet.</i>		<i>Acre-feet.</i>	<i>Acre-feet.</i>
January .....		1,100	July .....	684	2,763
February .....		3,300	August .....	504	3,020
March .....	721	1,415	September .....	142	654
April .....	737	4,046	October .....		1,868
May .....	729	4,081	Season .....	4,084	23,482
June .....	567	1,235			

Six hundred and twenty-five acres were watered below the gauging station on lateral 1 Modesto district, and 2,625 acres were supplied below the gauging station at lateral 3 Turlock district. Up to May 1 approximately one-third of the amount run in both laterals was spilled back into the river at their lower ends. Deducting these amounts, a total of 3,598 acre-feet was used or wasted on lateral 1 Modesto district, and a total of 20,195 acre-feet was used or wasted on lateral 3 Turlock district. In Modesto district this was sufficient to cover the 625 acres irrigated to a depth of 5.76 feet, or, differently expressed, was 1 cubic foot per second average flow throughout the season of one hundred and seventy-four days for each 60 acres irrigated. In Turlock district the amount run was sufficient to cover the 2,625 acres irrigated to a depth of 7.69 feet and enough to water 70.9 acres per cubic foot per second average flow from the time water was turned in until it was turned out, two hundred and seventy-five days.

There is no doubt that too much water is used by a majority of the irrigators in both Modesto and Turlock districts. In 1904 less was used in Turlock district than in Modesto district because much of the land in Turlock district had been irrigated since 1901,<sup>a</sup> and also because Turlock canal was closed for repairs for twenty-seven days in June and July, when the use would naturally have been large. To irrigate all of the land in the two districts under the duty obtained in 1904 would require a mean flow of 1,900 cubic feet per second in Modesto canal and of 2,700 cubic feet per second in Turlock canal. There is no likelihood, however, that such a low duty will continue long, because there will be several factors tending to increase it. The subsoil in both districts is generally deep, and for the first few years of irrigation can absorb large quantities of water without injury. As the level of the ground water is raised less water will be absorbed by the lower strata and therefore less will be required to supply the layer utilized by crops. Also, as irrigators become more experienced they will learn to get along with less water, and as the irrigated area in the

<sup>a</sup> Mr. B. W. Child, superintendent of Turlock canal from 1901 to September, 1904, reports that in 1901, 3,757 acres were irrigated in Turlock district; that in round numbers 7,000 acres were watered in 1902, and that 12,000 acres were watered in 1903.

districts becomes increased the district officers will be compelled to prevent all waste.

In Modesto and Turlock districts, however, as in all newly irrigated sections, the danger of using too much water is a grave one, and if the excessive use is allowed to continue large financial loss will be inevitable. If the tendency to waste, already very marked, can be checked before it becomes a habit, the saving to the districts and to the irrigators, both in money and in friction, will be, relatively speaking, almost beyond estimation.

In order to bear out the records of flow for the season already given, the amounts of water applied in single irrigations under single laterals and on separate farms were measured in a number of instances. These measurements showed excessive use or excessive waste in nearly every case. Between May 28 and June 6 enough water was run in one lateral in Modesto district to irrigate 611 acres, principally alfalfa, to cover the land irrigated to a depth of 1.8 feet. What proportion of this was lost in transit was not determined, although it was known to be large. On another lateral in Modesto district 13 farmers, with 292 acres, received enough water between June 19 and July 11 to cover their land to a depth of 1.2 feet. One farmer on lateral 1 in Modesto district used 21 cubic feet per second for twelve hours on 10 acres of alfalfa, which was enough to cover the land to a depth of 2.1 feet. Another farmer, one of the best in Modesto district, covered 26 acres of alfalfa on lateral 7 to an average depth of 0.54 foot in one irrigation, while a neighbor on an adjoining lateral used 18.5 cubic feet per second for eighteen hours on 16 acres of alfalfa, which was enough to give an average depth of 1.6 feet. These figures, which are in no way exceptional for Modesto and Turlock districts in 1904, show that individual practice is by no means guiltless of waste. It is believed that the high levees and imperfect leveling are the cause of much of the excessive use. Even on light soil a depth of 6 inches for each watering should suffice for alfalfa in Modesto and Turlock districts, but many checks are so far from level that a depth of 1 foot of water on one portion of a check often gives a depth of only 1 or 2 inches in another portion of the same check, resulting in great unevenness in applying water and much injurious waste.

#### QUALITY OF WATER.

The water of Tuolumne River is characterized by Prof. George E. Colby, of the University of California, as "exceptionally pure." A composite sample from the river at Lagrange dam, taken from May 1 to July 1, 1904, analyzed by Professor Colby, showed a total of only 2.32 grains per gallon of solid matter. Composite samples taken from Modesto and Turlock canals at Waterford and Hickman, respectively, 22 miles below where the river water sample was taken at Lagrange dam,

showed that this "exceptionally pure" character was not lost through the water passing down the canals. In neither Modesto nor Turlock canals were the solid ingredients increased sufficiently to either improve or injure the water. In Modesto canal the total grains per gallon increased to 3.19 and in Turlock canal to 6.39. In the former the sodium chlorid increased to 0.81 grain and the sodium carbonate to 0.35 grain per gallon, the other solid ingredients remaining substantially the same as at the head gates. In the latter the potassium sulphate (trace) and the sodium sulphate increased to 2.76 grains, the sodium carbonate to 0.61 grain, and the organic matter and chemically combined water to 1.74 grains. The complete analyses for the three samples are given in the summary below:

*Analyses of composite water samples from Tuolumne River and Modesto and Turlock canals.*

[Grains per gallon.]

Ingredient.	Tuolumne River at Lagrange dam.	Modesto canal at Waterford.	Turlock canal at Hickman.
Potassium sulphate (trace).....	0.50	0.58	2.76
Sodium sulphate (Glauber's salt), etc.....			
Sodium chlorid (common salt).....	.12	.81	.12
Sodium carbonate (sal soda).....	.25	.35	.61
Calcium and magnesium carbonates, etc., small.....	.87	.87	1.16
Calcium sulphate (gypsum), small.....			
Silica, chiefly.....			
Organic matter, no "char," and chem. combined water.....	.58	.58	1.74
Total.....	2.32	3.19	6.39

**SEEPAGE LOSSES.**

Of 90,795 acre-feet of water diverted from Tuolumne River in 1904 by Modesto canal, 76,717 acre-feet reached Waterford, near the entrance of the canal into the district. Of 166,845 acre-feet diverted by Turlock canal, 136,753 acre-feet reached Hickman. These figures show respective losses, in approximately 22 miles in each case, of 15.5 and 18 per cent, which were equivalent to a continuous flow through the season of 26 cubic feet per second in Modesto canal and 55 cubic feet per second in Turlock canal. Considering the size of Modesto and Turlock canals and the nature of the country through which they pass, these losses are not as large as might have been expected. Below Waterford and Hickman, however, and especially in some of the laterals, the losses are known to be excessive. While it was deemed desirable to determine these losses by a series of current meter gaugings, breaks in the canals and other circumstances prevented this being done, except on a section of Modesto canal from Lagrange dam to the head of lateral No. 6. A series of such measurements was made on this section in June, 1904, by Mr. A. P. Stover, of the irrigation and Drainage Investigations, and the writer, and the measurements showed the approximate location of the principal losses.

From Lagrange dam to lateral No. 6 is 33 miles. Starting with a flow at the dam of 260 cubic feet per second, the losses were found to be as given below:

*Summary of losses from main canal, Modesto irrigation district, between Lagrange dam and the head of lateral No. 6, June, 1904.*

Section of canal.	Loss.	Loss per mile.	Per cent.
	Cu. ft. per sec.	Cu. ft. per sec.	
Lagrange dam to Morton flume.....	9.2	3.9	.....
Morton flume to Dallas bridge.....	17.4	1.4	.....
Dallas bridge to gauging station near Waterford.....	14.0	2.6	.....
Gauging station near Waterford to lateral No. 6.....	15.5	1.3	.....
Lagrange dam to lateral No. 6.....	56.1	1.7	21.5

From Lagrange dam to lateral No. 6 the loss is seen to have been equivalent to a flow of 56 cubic feet per second, or 21.5 per cent of the 260 cubic feet per second started with. The greatest loss per mile took place between the dam and Morton flume, principally in sections that are now being repaired. From the dam to the gauging station near Waterford the loss was substantially 15.6 per cent, which is slightly more than the loss indicated by the total flow of Modesto canal for the season, given in acre-feet on page 110.

#### CROPS GROWN IN MODESTO AND TURLOCK DISTRICTS.

Water taxes are paid on 250,000 acres of land in Modesto and Turlock irrigation districts, but up to the close of the season of 1904 less than 30,000 acres were irrigated. The area irrigated, however, will increase each year, the prospects being that in 1905 it will be at least one-fourth larger than in 1904. Until water was turned into the canals—in 1904 in Modesto district and in 1901 in Turlock district—the whole area in the districts was a grain field. The purpose of watering, however, was to make possible a more diversified and more profitable agriculture than wheat growing on a worn-out soil. Because it is not difficult to raise under irrigation, and at the same time promises quick returns, alfalfa was fittingly chosen as the crop for making a beginning under the new régime of irrigation. It is therefore the principal irrigated crop in the districts. If sown there in time to get started in April it yields from one to three cuttings and good pasture the first season. There is every reason why its growth in these districts should be encouraged. It surpasses all other American forage crops, so that it is invaluable in the raising of beef and dairy cattle. As a renewer of impoverished soils, such as those in San Joaquin Valley, no crop grown on an extensive scale has yet been found to surpass it. A yield of 5 to 6 tons per acre each year after the first, gathered in three or four cuttings and worth \$4 to \$5 per

ton in the stack, is a highly satisfactory gross return for such a crop on land that can be purchased and planted and prepared for irrigation for \$75 per acre or thereabouts. Granting, however, all that may be said in favor of alfalfa and the ready market for it that is offered by the beef and dairy interests, it would seem to be false economy to raise it to the exclusion of almost all other field crops. It is questionable if even 7 tons of alfalfa per acre per year would be the best return possible from much of the land in the districts. For soil that will raise as wide a range of products as can be grown in these districts, some crops should be found which, rotated with alfalfa and grain, would give a more balanced and, in the long run, more profitable production than can be derived from any single crop, even if that single crop is alfalfa. Careful rotation in the South Platte Basin in northern Colorado has so increased values that alfalfa is now raised there more as a means of preparing land for more profitable crops, in the meantime giving a fair return, than as the ultimate and most profitable crop. Conditions are obviously different in San Joaquin Valley from conditions in the Rocky Mountain irrigated sections, yet the people of Modesto and Turlock districts should not fail to search for the crop or crops that, interchanged with alfalfa and wheat, will give them the largest possible yield from their land.

Although the chief crop, alfalfa is not the only crop grown under irrigation in these districts. Others are deciduous fruits of various kinds, including grapes, mostly for wine. The conditions seem admirably adapted for all of these, and the extent of their profitable production will depend on the prices at which the markets will be likely to receive them. In the lighter soils around Turlock sweet potatoes are now grown with considerable profit, the yield of 1903 averaging 125 sacks of 115 pounds to the acre. These were sold at the nearest railroad station at from 80 cents to \$1.40 per 100 pounds, averaging \$1.10 per hundred, which gave a good profit to the growers. In 1904, 1,100 acres were planted to this crop in Turlock district. Corn can be raised almost to maturity in the districts without water, but requires irrigation in May or June to carry it through the hot winds of those months. Much of the soil is suited to the growth of sugar beets, but whether they can be grown there has not been determined by trial, although a considerable acreage will be planted to this crop in 1905. Egyptian corn, melons, beans, garden truck, and numerous other field crops are being tried. Of the fruits, the Calimyrna fig is considered by many as admirably adapted to the conditions present, and considerable areas have already been planted, particularly around Ceres, in Turlock district. Small fruits, such as loganberries and blackberries, grow luxuriantly and yield abundantly, and should be profitable when properly raised and marketed. Oranges and lemons grow and yield wherever planted in the districts, and in the foothill country east of



the districts, as around La Grange, reach a high state of perfection. They are not, however, being grown commercially in the districts to any considerable extent.

One of the most surprising features of farm practice around Modesto and Turlock is that no grain is irrigated. This becomes the more surprising when yields of wheat on summer-fallow land are reduced to 10 or 12 sacks per acre every other year, and when every acre of dry-farmed grain land pays the same water tax as every acre of irrigated alfalfa or vineyard. Grain growers in all parts of the West, except portions of California, water their crops with highly satisfactory results. If, as Modesto and Turlock grain growers claim, wheat and barley can not be profitably irrigated in their section on a large scale, there is little doubt that much would be gained by watering it on such a scale as farmers of 80 or 160 acres of land might do. If, after several years devoted to alfalfa, 40 acres of irrigated wheat would yield at the rate of 50 and 60 bushels to the acre—yields which are by no means uncommon where wheat is irrigated and carefully rotated with other suitable crops—the wisdom of irrigating grain would seem to offer little ground for controversy. In the spring of 1904 the experiment of irrigating grain was tried on one of the farms of Mr. C. N. Whitmore, near Ceres. Two acres of barley were watered on May 3, after the grain was headed, by flooding from small field ditches. An average flow of 0.75 cubic foot per second was used, covering the land to an average depth of 0.27 foot. The experiment demonstrated that the light soil on which the experiment was tried could be readily irrigated by the method followed, although it was shown that a larger "head" than was used would give the best results. Although the experiment was tried late in the season, the yield and quality of the grain were materially improved.

#### METHODS OF APPLYING WATER.

The check method is followed almost exclusively in applying water to land in Modesto and Turlock districts. This method was copied from other sections in San Joaquin Valley, where it has found much favor with irrigators. That it is the best method for all the land in these districts has not, however, been determined, and, taking experience of irrigators elsewhere as a guide, it is quite certain that some other method would be better on some of the land. In this country this method had its origin among Mexicans, who carried it from their own country to San Joaquin Valley and other parts of California. The main theory underlying it—that it permits of irrigation with a minimum of labor—is certainly a point in its favor, yet this should not be allowed to dictate its adoption. The application of water to crops is more than a matter of opening and closing head gates. The

history of wheat growing in San Joaquin Valley should be sufficient illustration of the economic axiom that the minimum of labor gives the minimum of yield. On land with little slope and light texture, where water spreads with difficulty, the confining between levees of a comparatively large stream of water for a short time is certainly good practice. On land sloping as much as 1 foot in 100 feet, however, where water will spread even on light soil, the breaking up of the soil surface into levees at a cost of \$18 to \$30 per acre is a practice at least sufficiently questionable to warrant careful experimenting with other methods. One or two new settlers who have irrigated elsewhere are irrigating alfalfa by flooding from small laterals, as is done almost universally in the Rocky Mountain States, and also with success in some portions of California. On land with sufficient slope so that water will spread without being confined in checks, and where the soil is not too light, there seems no reason why this method should not succeed. It requires only the evening, not leveling, of the ground surface and the construction through the field of small laterals capable of carrying from 1 to 3 cubic feet per second, or from 50 to 150 miner's inches, of water. Water can be readily diverted from such laterals by metal tappoons or canvas dams, which force the water over the banks of the laterals or through temporary breaks in their sides, and guided over the field by an attendant. These laterals, generally from 50 to 100 feet apart, according to crop and other conditions, follow the tops of the ridges or along grade contours, in the former case so that the water may be run out on both sides of the lateral, and in the latter case so that they may be kept high enough to reach the different parts of the fields. This method of irrigation requires much more skill in handling water than the check method, yet where the laterals are properly made and the water is carefully handled and no low places are left in the field without outlets for surplus water, it will permit of a more even application of water than can be given by the check method where the checks vary more than 4 or 5 inches from level, as do many of the checks now built in Modesto and Turlock districts. If checks are within 3 or 4 inches of level, and not too large—the area being no greater than can be watered by the available irrigating stream without excessive watering of some portions before the water can be made to spread to the other portions—it is probable that water can be spread on them more evenly than it can be applied by flooding directly from small laterals.

But little examination of many of the check levees in Modesto and Turlock districts is needed to show that they are, as a rule, higher than necessary, and also that they very often have slopes too steep to permit of easy crossing with farming implements. Levees 2 to 3 feet high are not uncommon in these districts. Such excessively high

levees are not only very expensive to make, but they offer breeding ground for noxious weeds, produce little, if any, yield, and greatly detract from the appearance of irrigated fields. A number of irrigators in these districts, however, have made checks that have proven highly satisfactory, in which water can be applied to the crops both quickly and evenly. Detailed surveys were made of some of these in 1904 by Mr. A. P. Stover, of the irrigation and drainage investigations, and the writer, and descriptions taken from these surveys, together with suggestions regarding checks in general, prepared by Mr. Stover, are here given. In this connection helpful suggestions were made by Prof. M. E. Taylor, of Ceres, and Mr. L. F. Hastings, now superintendent of Turlock district. It is thought that the sketches and descriptions will offer something of a guide to those about to begin the construction of checks in these districts.

#### **PREPARING LAND FOR CHECK IRRIGATION.**

The settler who is about to prepare his land for irrigation with checks has the choice of two systems. He may use the contour system and locate all levees on contour lines, thus dividing his field into checks of varying size and irregular shape; or he may adopt the rectangular system, in which all levees are located on straight lines that divide the tract into checks essentially rectangular in shape. Which of these two systems is best of course depends entirely upon the particular case in hand, but the advantages of the one system as compared with the other may in the main be determined by two factors, viz, the nature and uniformity of the slope of the tract to be checked, and the use which will eventually be made of the tract.

If the given tract contains depressions or small swales, then, other things being equal, contour checks should be used, for, generally speaking, contour checks will be less expensive in construction than rectangular checks. Contour levees may be so located as to require a minimum amount of labor in their construction and in the leveling of the bottoms of the checks. In constructing rectangular checks, however, the partial disregard of contours, in order to build the levees on straight lines, results in much more earth having to be moved in order to properly form the levees and bring the beds of individual checks each to its own level. Under conditions where the slope of the tract is quite uniform in each direction and the surface is unbroken, rectangular checks would be the ones to choose, for, although under these conditions there would be practically no difference in the cost, the advantage is with the rectangular system from the fact that rectangular checks conform nicely to culture areas and to property and subdivision lines, and by so doing add materially to the general

appearance and attractiveness of the farm and to the ease with which it can be cultivated.

The use to which a tract of land is to be put may, to a certain extent, affect the style of checking adopted. Especially is this the case on land with uneven slopes. If on such land it is expected nothing but alfalfa or grain will be raised, it may not pay to go to the extra expense of building rectangular checks. On the other hand, if

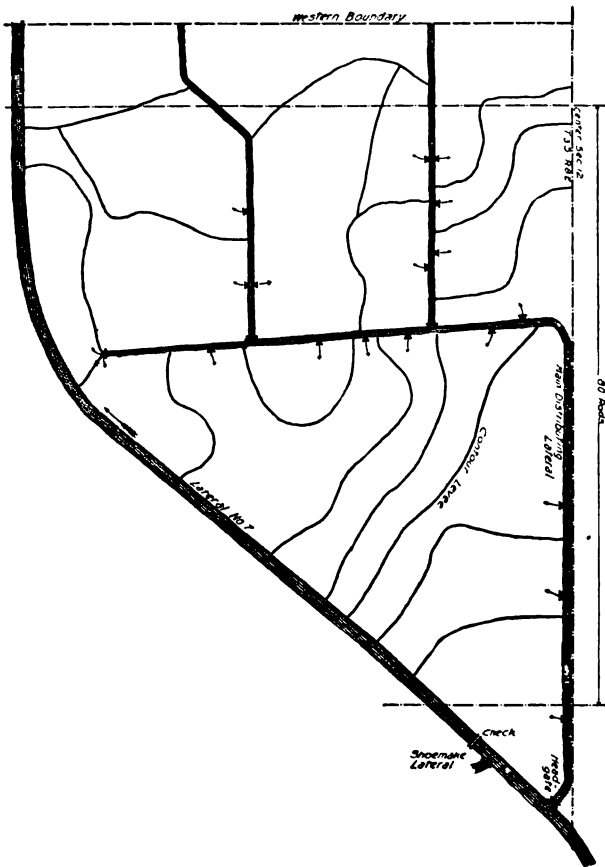

FIG. 2.—Irrigation by contour check system.

cultivated crops, such as fruit trees, vines, or furrow crops are to eventually occupy the land, then the added initial expense of providing large rectangular checks will more than be compensated for by the ease with which irrigation and cultivation may be accomplished.

As illustrative of the two styles of checking two sketches are given, based on field surveys. Figure 2 shows a typical example of good practice in the use of the contour system in the irrigation of alfalfa.

It represents part of the farm of Mr. George W. Horn, 3 miles northwest of Modesto. The rectangular check system is illustrated by

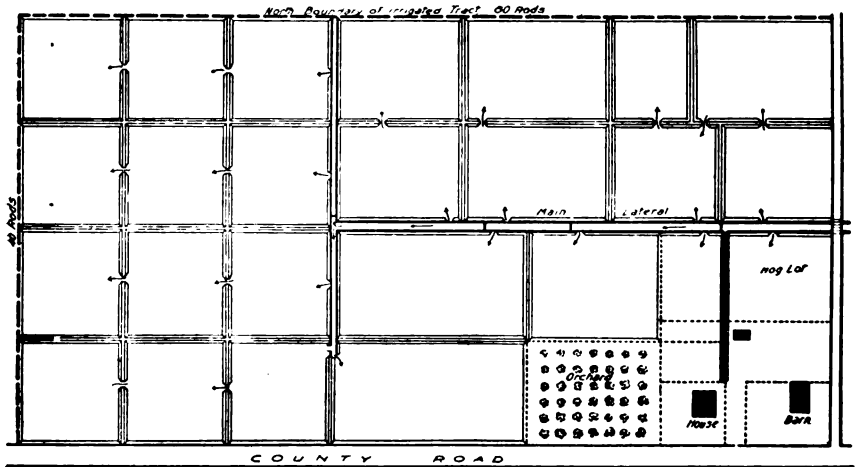

FIG. 3.—Irrigation by rectangular check system.

figure 3, which is a sketch of an alfalfa field belonging to Mr. Dan Baldwin,  $3\frac{1}{2}$  miles east of Ceres.

#### LAYING OUT CHECKS.

Regardless of whether contour or rectangular checks are to be used, the nature and amount of slope of a tract of land are the features which govern the location of levees and size of checks. On all land suitable for checking which has a slope of from 4 to 10 feet per mile, contours, or lines of equal elevation, must be located with an instrument. Some farmers, with the aid of cheap leveling devices, have tried laying out their own check systems. A few have been successful, but many, from a lack of knowledge of the conditions which should govern, have made costly blunders. Unless one is sure of his ability to succeed in such a task, he will save money by securing the services of a surveyor. The expense of this will of course vary with the roughness of the land to be checked, but a good man, with his instrument and one assistant, will outline checks on 25 to 35 acres in a day. At this rate the cost would be 20 to 30 cents per acre. The average farmer would doubtless have trouble in getting over more than 6 or 8 acres in a day, which, if he considers the time of himself and his helper, would make the cost 35 to 50 cents per acre. Not only, then, would it be more expensive for the farmer to do the surveying himself, but being unfamiliar with this kind of work, the chances are he would not make the best choice of location for levees and laterals, and that he would thus cause himself no end of labor and trouble in



FIG. 1.—CONSTRUCTING CHECK LEVEE WITH SCRAPER.



FIG. 2.—CONSTRUCTING LATERAL DITCH WITH SCRAPER.



constructing and maintaining his system of checks. Cases have occurred where, after having gone to much trouble to lay out their own checks, farmers have finally been forced to employ a competent surveyor to make a complete resurvey. However, for those who undertake the work without the help of a surveyor, the following suggestions may not be out of place.

After having determined the slope of the land, the next move is to fix the approximate size of the checks by the difference in elevation between checks. The best results are obtained where the vertical difference between checks is from 4 to 10 inches. By this is meant that, after the checks are built, the difference in level between the bottoms of two adjacent checks should be from 4 to 10 inches, depending on the general slope of the land. Observations in San Joaquin Valley suggest three-fourths acre to 1½ acres as the best areas for checks. With a tract having a uniform slope the difference in level between the tiers of checks would be a constant amount, and all levees would be approximately the same distance apart. The maximum difference in level between checks should not be over 1 foot. If greater than this, the levees between checks, especially on light soils, are apt to give way under pressure of the water, and when this happens the heavy fall to the next check causes a bad washout. Where the slope of the land is so great as to require a larger difference than 1 foot in order that the levees may not be less than 50 feet apart, the check system should be abandoned and some other method of applying the water adopted.

When the survey of a contour check system is being made usually no stakes are set, but the location line of each levee is marked by a shallow plow furrow, the course of which is indicated by the surveyor walking directly ahead of the plow. In laying out rectangular checks, the corners of checks are indicated by stakes, from which the levees are constructed. As a guide for bringing the bed of each check to a level, a few random stakes are set here and there between the levee furrows, all in any particular check having their tops on the same level.

#### CONSTRUCTING LEVEES AND LEVELING CHECKS.

The task of building levees and leveling checks is work that the farmer can do himself, and by so doing perhaps secure better results, by reason of his interest in the work, than if the work is done by contractors. Land which is to be checked is usually sown to grain or summer fallowed the previous year, so that the soil is in good condition to be handled with a scraper. Various implements are used in this work, but of all perhaps the best results are secured with Fresno and Stockton scrapers, especially where there is a long haul. (Pl. III, fig. 1.) For short hauls and for smoothing and leveling checks the ordinary buck scraper does rapid work.



With the levee furrows and the random stakes indicating the level of each check as guides, the construction of the levees and leveling of the adjacent checks can be carried on at the same time, the earth being dragged from the highest points of the check to the nearest low place in the levee. The object is, of course, to move the most earth with the least haul, yet at the same time to build a levee of uniform cross section. When the levee surrounding any check has been built to its desired size, the check inclosed, if the scraping has been done intelligently, will be nearly level, so that but little more work with the

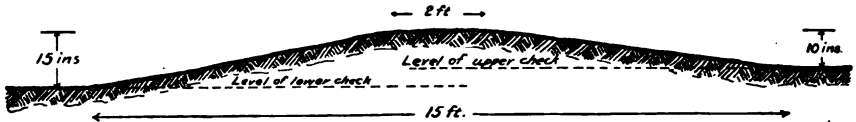

FIG. 4.—Cross section of levee with wide base.

scraper will be required to true up the surface. The more nearly level the bottoms of all checks are made the more easily will the water when admitted cover all portions. On new soil which has never been saturated it is not necessary to complete the leveling before the first application of water, for the reason that all new land settles more or less after first being saturated, and the final leveling should be left until after this settling has occurred. The surface of each check should be brought as near to a uniform level as possible. In one of the square checks shown in figure 3 twenty-five or thirty readings with the instrument taken at random over the check showed the maximum variation in level to be less than  $1\frac{1}{2}$  inches. When a

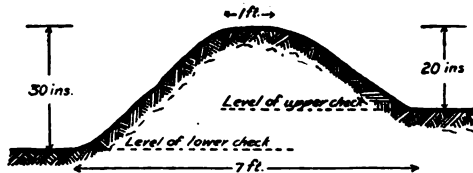

FIG. 5.—Cross section of excessively high levee with narrow base.

stream is turned into such a check the water soon spreads over the entire area and the irrigation is accomplished with a small amount of water. With level checks only a small depth of water is brought to bear on the levees, and the danger of breaks and washouts is materially reduced.

The difference in elevation between adjacent checks will determine the height of the levees. The crest of the levee separating two checks should stand 8 or 10 inches above the level of the higher check. Its top width should be not less than 2 feet, and its bottom width—say for a 1-foot levee—should be at least 15 feet. Such a levee (fig. 4) has easy-sloping sides and rounded top, over which all farming implements may easily pass in any direction and on which crops will grow

without difficulty. In both of the districts levees have been given a narrow base and steep-sloping sides (fig. 5). If this has been done to avoid encroaching upon the area of the check, an unwise move has been made. Where levees are steep sloped with narrow base, no implement can be taken over them without danger of damaging the levees as well as the implement, and no crop will grow on such a levee. The chances of the levees breaking under water pressure are increased by their diminished cross section. Levees built broad and low form no obstruction in the field; they are more lasting, and owing to their flat slope the crop grown, if it be like alfalfa, will entirely cover the levees, and the whole area of the field is made productive.

DISTRIBUTING LATERALS.

The location of laterals will be governed by the character of the slope of the ground. On light soils a grade of 2 or 3 feet per mile should be the maximum. In general, the best results will be obtained if each check is supplied directly from a lateral. Such an arrangement is shown in figure 2 (p. 121), each check being flooded directly from the lateral that forms a portion of its boundary. In practically

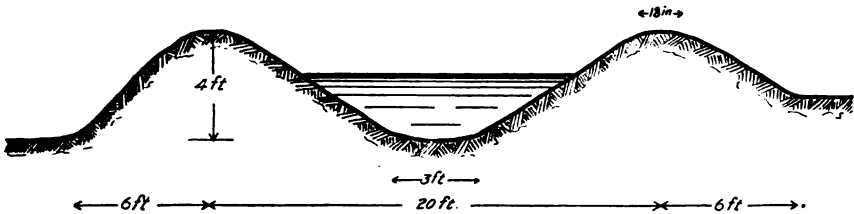

FIG. 6.—Cross section of well-made laterals.

all cases such an arrangement of laterals is possible, and where the expense of constructing the extra channels required is not prohibitive this plan should be adopted. In cases where it is necessary to supply one check through another, a broad shallow depression across the check through which the water is to be carried will confine the flow of the stream and lead it to the check to be watered without its spreading over the bottom of the higher check. If this depression be made 10 or 12 feet wide and 4 to 8 inches deep and given just enough slope to drain nicely toward the lower check gate, the crop will cover the sides and bottom of the channel, and all implements will cross it without inconvenience.

In the construction of laterals the scraper is worked at right angles to the line of the lateral, as shown in Plate III, figure 2. The earth to form the banks is taken from the bottom of the channel and from the high parts of adjacent checks. In figure 6 a good section for an ordinary-sized lateral is shown.

### SETTING CHECK BOXES.

Various forms of check boxes are used, the size depending on the amount of water to be controlled. Serviceable boxes can be made of 1-inch or 1½-inch lumber, with 2 by 4 framing timbers. If made of redwood, such boxes should last ten to twelve years. Whatever the style of box used, it should be so constructed and puddled, when set in the banks of the lateral, as to withstand the greatest pressure of water that will be brought to bear upon it. Flashboards should be made of 2-inch lumber, preferably 6 inches wide. With this thickness of lumber the boards will not warp out of shape when left in the sun. In setting boxes the floor should be placed 10 or 12 inches below the level of the check to lessen the liability of the water washing under the boxes as it leaves the lateral. For average land good check boxes can be provided for from \$4 to \$5 per acre.

### COST OF CHECKING.

No exact estimate can be given of the expense of checking, as the price will vary widely with the character of the land. For contour checks, the cost of building levees, leveling the checks, and constructing laterals will average about \$7 or \$8 per acre on ordinary land, including surveying at 20 to 30 cents per acre. Check boxes at \$4 to \$5 per acre would bring the total expense up to \$12 or \$15 per acre. In building rectangular checks on uniformly sloping land one man with four horses and a scraper can check and level at the rate of 1 acre in two to two and one-half days. In exceptional cases one man, if the land be quite smooth, can do this work at the rate of an acre a day. This would not include the construction of laterals.

### GROUND-WATER RECORDS.

Experience in other irrigated sections justifies the presumption that sooner or later the level of the ground water underlying the surface of the soil in Modesto and Turlock districts will rise in places to the point of injury to crops. When this takes place the saturated land will have to be either drained or abandoned. Some data were collected in 1904 to ascertain the ground-water conditions in these districts, with a view to indicating the direction in which the people of these districts will need to take steps to forestall injury. Besides obtaining miscellaneous figures as to the rise of the ground water in both districts since irrigation began, systematic records were obtained weekly during the season from 15 wells in Modesto district. These wells were scattered in a linear distance of 30 miles, extending from Modesto east along the Waterford road to Waterford; from Modesto north along the McHenry road to the farm of Mrs. I. T. Bangs; from the

Southern Pacific main track, near Salida, west along the McNeal road to the farm of Mr. A. Shearer; and from Modesto west along the Maze road to the farm of Mr. C. D. Butler. The first measurements were made in April and May, and the last ones in October, except that some of the voluntary observers failed to send any reports for the last part of the season. The table below shows the results of these measurements by months, the names of the observers, and the location of the wells. The figures for each month represent the maximum rise during the month, but do not show the fluctuations from week to week.

Table showing rise of ground water in 1904, in sections of the Modesto irrigation district, as indicated by reports from 15 wells.

Name of observer.	Location.	Depths to water, by months, in feet.							Maximum change during season.	Net change for season in feet rise (+) and fall (-).
		Apr.	May.	June.	July.	Aug.	Sept.	Oct.		
C. J. Parry (Spanker farm).	Waterford road	40.80	40.25	39.85	39.35	38.75	38.50	38.70	2.30	+2.10
T. K. Beard	do	44.85	44.60	44.25	43.85	43.50			1.35	+1.35
J. A. Turpen (Davison road).	do	62.00	61.00	61.00	65.00	65.50			4.50	-3.50
E. M. Welch	do	75.00	75.75	75.60	75.35				.75	-.35
U. G. Bradley	Waterford	78.25	78.00	77.40	77.40	77.40			.85	+.85
J. C. Geer	McHenry road.	29.25	28.25	27.15	25.10	24.50	26.65	26.90	4.75	+2.35
J. H. Boren	do	32.10	31.60	31.15	31.65		30.65		1.45	+1.45
Mrs. I. T. Bangs	do	31.00	30.65	29.15					1.85	+1.85
J. T. Gish	McNeal road	19.75	18.85	18.95	17.95	17.85			1.90	+1.90
B. C. Campbell	do	15.00	15.00	15.00	15.00	15.00			.00	.00
C. M. Beckwith	do	15.70	15.55	15.70	15.60	15.25		14.00	1.70	+1.70
L. W. Shearer (A. Shearer farm).	do	12.75	12.90	12.00	11.60				1.30	+1.15
C. M. Maze	Maze road	29.60	28.66	27.85	26.15				3.45	+3.45
W. E. Garrison	do		22.65	22.00	21.60		22.00		1.05	+ .65
C. D. Butler	do		13.75	13.50		12.00	11.95	12.75	1.80	+1.00

The last column in the table shows that there was a net rise for the season in all but 3 wells, and that the greatest net rise in any of the 15 wells was 3.45 feet, on the farm of Mr. C. M. Maze, 1 mile west of Modesto. This well is within one-fourth mile of a main lateral and near land that was irrigated. The well on the Davison farm, reported by Mr. J. A. Turpen, is within a few hundred feet of Tuolumne River and shows no results of value. The wells reported by Mr. U. G. Bradley and Mr. E. M. Welch are outside of the irrigation district, but within one-half mile of Modesto canal. The casing in the well reported by Mr. B. C. Campbell is of new galvanized material, with soldered joints which cut off connection with surface water, and no change was shown throughout the season. Five of the wells showed a net rise for the season less than the maximum change, indicating that the level of the ground water began to recede toward the end of the season when the amount of water carried in the canals and applied to the land decreased. In no case was the rise very marked.

Mr. D. P. Howell, formerly a well borer of considerable experience in Modesto and Turlock districts, states that up to the fall of 1903, and since water was turned into Turlock canal in 1901, there has been a rise in the ground-water level in parts of Turlock district of 16 to 18 feet. Shortly after making the observations on which this statement was based, water was out of Turlock canal for two months, and during this time the boring of 5 wells showed that the water level returned to nearly its original level. Mr. P. W. Christensen, engineer on the Bald Eagle ranch, 5 miles north of Modesto, reports that when water was first turned into Modesto canal in 1903 the water in a well on this ranch rose 1.5 feet in three weeks, and that the rise in the nine months prior to October, 1904, was 7 feet. The main canal of Modesto district is one-half mile from this well and the well is in the center of an irrigated tract on which a large amount of water was used in 1904. The most dangerous rise of ground water so far has been in sections of Turlock district, where water has been used since 1902. According to the reports of a number of old settlers, the water levels in the wells around Turlock originally stood 20 feet below the surface. Measurements made in 1904 showed it to be within 7 to 9 feet of the surface. Water has been running in lateral No. 4 of Turlock canal, one-half mile north of Turlock, for three seasons, and from 200 to 500 acres have been irrigated. Nearer this lateral water was found within 3 to 5 feet of the surface in October, 1904, and it has also been found within a few feet of the surface in other parts of the district.

While the data given above are incomplete they are sufficient to show that the problem of ground water is one that already demands the attention of the people of these districts. The soil is generally of a sandy nature, allowing water to percolate rapidly from canals and laterals, and encouraging the use of excessive amounts of water in irrigation. The surface soil is as a rule underlaid with a hardpan layer, varying in hardness and thickness, sometimes appearing on the surface and sometimes found 5 or 10 feet and even more below. The uneven plane of this hardpan layer, as well as its uneven texture, some being fairly impervious and some rapidly softening when wet, will cause the rise of the water plane to be more pronounced in some spots than in others, as it will also cause the immediate effects of excessive irrigation to vary with locality. The danger will of course first appear in the lower sections of the districts where water is naturally not far below the surface. In the higher sections it will be first evident along canal and lateral banks and in the depressions.

It is without doubt one of the legitimate functions of the district organizations to watch the rise of the ground water, and it is believed that it will make no mistake in taking steps to do so. If every farmer would watch the water level in his own well and report to the district

authorities, the labor and cost of this would be greatly reduced. Preventive measures prior to injury, such as the lessening of leakage from canals and the lessening of waste in irrigation and drainage after injury, will be fields of effort in which the districts will be compelled in self-defense to exercise such prerogatives in these regards as the irrigation district law gives them. The prevention of leakage and waste is unquestionably both a right and a duty of the districts, and the getting of results in drainage would be greatly simplified if the irrigation district law were amended to permit joint action in drainage without any additional organization, such as the drainage law of the State requires. Some kind of effective cooperation in drainage will eventually be necessary in these districts, and it would seem to be an unnecessary complication to organize drainage districts for that purpose, which is the method provided by law, when the irrigation districts already provide the necessary organizations.

### THE DISTRIBUTION OF WATER.

Modesto and Turlock districts have before them no small task in devising systems of water distribution that will result in the economical and just division of water among their many irrigators. Especially is this true because such systems, if effective, will require the active and business-like cooperation of several hundred—eventually several thousand—individual farmers, mostly untrained in the ordinary methods of business and unused to working together for a common purpose. These men have not only to learn by experience and careful study what distributive systems are best suited to their needs and conditions, but perhaps more difficult, they have to learn to stand by each other and their officers in carrying into effect the systems they choose. Each individual irrigator is conscious of his right to help manage the affairs of the district, but is not always careful to be sure of his facts before complaining, or, in the face of complaints from others, to stand by the officers he helps to elect. Very naturally the result is not always happy. In fact, it clearly indicates that if the relations between the irrigators and the distributing officials are to be congenial and the highest possible duty is to be obtained for the water of the districts improvements in distribution will have to be made. It is a settled rule in business that no enterprise of magnitude can succeed without system. There seems no reason why Modesto and Turlock districts, with \$2,500,000 invested in canals that cover a quarter of a million acres of fertile land, are exceptions to this rule. So far, however, Turlock district has not even equipped a district office nor furnished the superintendent with the conveniences necessary for the conduct of his work, and this despite the fact that water has been in Turlock canal for four seasons. It is believed that the irrigation and

drainage investigations can do Modesto and Turlock districts no greater single service than to urge upon them the necessity for giving greater attention than they have in the past to the details of water distribution. While it is true that water in some amount can be delivered to some of the farmers without any system and that in some way or other crops can be raised and settlement increased, there is no plainer fact in connection with these districts than that, without careful regard to what becomes of the water diverted by the canals and to the methods by which it is divided and applied to the land, these districts will fall far short of their opportunity to make this section one of the most attractive places in California for the farmer of small means. So far the cost of water in these districts has been much less than in most irrigated sections, and eventually, as the bonds are paid off, the cost will decrease. With the careful use of water and sensible cropping and methods of culture, a wide range of products can be grown. Markets for the purchase of supplies are close at hand, and facilities are ample for the transportation of the products of the irrigated farms. There is no more stable branch of agriculture in the West than the raising of beef and dairy cattle, and there is no extensive area in California better suited to it than these districts. The climate is healthful, even if slightly oppressive in some of the summer months, and good land is plentiful and can be purchased at reasonable figures. There is opportunity for every farmer to raise the principal staples and some of the luxuries of his home food supply, and there are sufficient near-by markets to absorb the surplus of the poultry yards and vegetable gardens. With the opportunities of building up thriving rural communities which these natural advantages offer, the districts would surely fall far short of their duty if they hindered future progress by failing to provide the machinery for economical water distribution, a needed assurance to intending settlers that they will be protected in their right to an ample water supply.

It is believed that the first essentials of distributing systems for these districts are records of the amount of water being diverted and used, and of the time and amount of water delivery to irrigators. These records can be kept under the direction of the superintendents by the caretakers and ditch riders along the canals and laterals, and with slight expense to the districts, except that to make them of value they will have to be gathered on forms furnished by the districts, in strict compliance with instructions from the superintendents, and later systematically filed in the district offices. The records showing the amounts of diversions from the Tuolumne will aid in establishing a definite water right for the districts, and when compared with the area irrigated and the area to be irrigated, will give an index of how much diversions will have to increase or how much use will have to decrease before all of the land in the districts can receive water. Records of

the daily diversions from the main canals by the laterals will tell if the different sections are receiving the proportions of the supply due them, and will be a definite guide to the superintendents and ditch riders in dividing water among the irrigators. Records of the time water is delivered to each irrigator and of the amount of land watered by each farmer at each irrigation will furnish evidence to the superintendents that ditch riders are or are not doing their duty, and will be an official basis for settling disputes with irrigators as to whether they have received their just share of the supply. If compiled and published, these records will be a guide to new settlers in the districts as to the amounts of water it is customary to apply to the various crops raised in the districts. They will also awaken an interest among the farmers in the affairs of the districts which almost no other agency would arouse. A beginning was made in gathering these records in 1904 by the irrigation and drainage investigations, and the favor with which they were received by the irrigators and the deductions possible from them are adequate proof that the districts will make no mistake in continuing them. These records show for 1904 the daily diversions for both Modesto and Turlock canals at Lagrange dam, the amounts entering both districts each day 22 miles below the dam, and the amounts used on lateral 1 in Modesto district and on lateral 3 in Turlock district.<sup>a</sup>

The keeping of records is not, however, all there is to a distributing system. There must first be a basis that determines how much water each irrigator shall receive. The law under which the districts operate provides, in section 18, "that all waters distributed for irrigation purposes shall be apportioned ratably to each landowner upon the basis of the ratio which the last assessment of such owner for district purposes within said district bears to the whole sum assessed upon the district." Without accurate measuring facilities at the head of each farm lateral, which can not be found at present in either district, the letter of this law can not be followed, and the result is that in practice no attention is given to it. Instead, water is distributed in proportion to the area being irrigated, which, so far as the irrigators on any one lateral are concerned, and barring fine points of exact justice, is certainly the more sensible and more feasible plan. It would

---

<sup>a</sup> Since the above was written, Modesto irrigation district has adopted forms for the keeping of records of water delivery and use in accordance with suggestions by the irrigation and drainage investigations and the superintendent of the district. These forms are for keeping daily records (1) of the amount of water diverted by Modesto canal at Lagrange dam, (2) of the amount reaching the district line near Waterford, (3) of the amount diverted from the main canal by each lateral, (4) of the time water is delivered to each irrigator, and (5) of the work performed by each ditch tender. Each ditch tender is provided with a book for keeping the records and with cards and blanks for forwarding weekly reports to the superintendent, and the latter are to be filed in the Modesto irrigation district office in Modesto. These several forms are shown at the end of this report. (See pp. 137-139.)



be quite difficult at present even to prepare a schedule of delivery that would follow the letter of the law and give water to each landholder in proportion to the taxes paid by each, especially considering that no water whatever is now needed or desired for a large part of the land within the districts. A temporary disregard of that part of the law providing for this basis will work no hardship, nor will it be likely to cause any difficulty, because in a new section, where the water supply is not severely taxed, all expect to give and take for the common good. It should not be forgotten, however, that practice eventually becomes settled policy, which it is always difficult to change. If it appears clear that water can not be distributed in irrigation districts in proportion to assessments paid (and experience in Modesto and Turlock districts should in large part be conclusive as to this), an effort certainly should be made to have the law changed to provide a basis of division that can be followed. No matter how impracticable of application a law may be, when water becomes more difficult to get, and hence more valuable, some one will be certain to demand the strict enforcement of the law, regardless of what may be the consequences to others. Such has been the lesson of irrigation throughout the West. Modesto and Turlock districts will take no unnecessary precaution if they forestall any such result by seeing to it that the law and the fact coincide.

The question of whether water should be distributed on a time basis, or whether each irrigator should receive a small flow continuously, is being met in a practical way in Modesto and Turlock districts. As a rule, each irrigator is allowed a "head" of water for a length of time in proportion to the number of acres he is watering. In Modesto district the head is considered to be 9 cubic feet of water per second, and the rules provide that no irrigator shall be allowed such a stream for more than one hour for each acre. In Turlock district the head is made 6 cubic feet of water per second, which is allowed for one hour per acre, except in time of low water, when the rules provide that proportionately less shall be given. If, instead of the usual head for a limited time, irrigators raising garden truck or other crops requiring frequent watering desire a small stream running continuously, an effort is always made to supply it.

As a matter of fact, while the "heads" mentioned above are provided for in the rules of the district, in practice irrigators are given what their laterals will carry, or what the ditch tenders can deliver to them. This amount varies widely above and below the limits set in the rules. Nothing else can be done, because there are no measuring devices at the heads of these laterals, and the ditch tenders can not measure water without them. Within a very few years it will be necessary for the districts to insist on having such measuring devices.

This will be demanded not only by the interests of the individual irrigators, but also by the interests of the whole number of irrigators represented by the districts. If experience of irrigators elsewhere is any guide to what will best preserve harmony in Modesto and Turlock districts, each district should demand as nearly uniform measuring devices as it will be practicable to install. This the districts unquestionably have authority under the law to do. Not only should these measuring devices be uniform, but they should measure with approximate accuracy. It is believed that it is practicable to install such devices in most of the farm laterals. Many such devices have been designed in the West, but few have proved entirely satisfactory. What is the most satisfactory type it is not now possible to determine, although it is probable that light will be thrown on this subject by the investigations of small measuring devices now being conducted by the irrigation and drainage investigations in several States in the West. When there is sufficient grade in the farm laterals to give the required free overfall, no device is likely to be designed that is superior to the Cipolletti weir. On many of the laterals in Modesto and Turlock districts, however, the necessary fall is not available, and consequently some modification of the rating flume or opening under pressure will have to be adopted.

The vital point in any distributing system is in getting competent and tactful ditch tenders, and in providing the canal superintendent with sufficient help, so that their work can be properly supervised. Men of good judgment can divide water with fair satisfaction if they are provided with no measuring devices whatever. Constant practice enables them to estimate the desired "head" with a considerable degree of accuracy. With proper measuring facilities, however, their work is very much more satisfactory. If ditch tenders in Modesto and Turlock districts could look forward to promotions and increases in salaries at definite times for efficient and faithful service, so that there would be inducements for them to remain permanently in the service of the districts and to prepare themselves for their duties, it would be possible to secure better trained men than are now employed. To be thoroughly competent a ditch tender charged with distributing water to irrigators should be familiar with the ordinary units of water measurement, and with the more simple methods of measurement—that is, he should know the meaning of such common terms as "miner's inch" and "cubic foot per second," and should be able to install and use such devices as measuring weirs or flumes. He should also understand thoroughly the basis on which water is being divided, the approximate water requirements of the principal crops, the evils and evidences of overirrigation, and how to apply water to land. With this knowledge, practical experience in repairing breaks, energy, tact,

and faithfulness, a ditch rider could make himself the most useful man in the community, and have his advice sought and followed by irrigators. It is not reasonable, however, for the districts to expect to get men with these qualifications unless a greater reward is promised than the present wage of \$50 a month, or \$60 a month where a horse is needed. In 1904 Modesto and Turlock districts together paid out not to exceed \$10,000 for the services of ditch tenders charged with the division of water. This water made possible the production of crops worth at the least a quarter of a million dollars. It is entirely reasonable to suppose that better trained ditch riders would have greatly increased the output of the 27,000 acres that were irrigated. An increase in value of only 25 cents an acre would have made good a substantial addition to the salaries of the men who divided the water, besides providing the salaries of at least one overseeing assistant to aid each superintendent.

Both Modesto and Turlock districts offer excellent opportunities for the organization of local associations of water users, especially of those taking water from any one lateral or sublateral. Central associations for each district have already been formed, but it is believed that as the interests of the irrigators on any lateral or sublateral become more closely welded, as they will when more land is brought under irrigation, the irrigators will find it to their advantage to organize. The main laterals will some day bear the same relation to the main canals as independent ditches on many streams bear to the streams from which they lead, and while the interests and rights of the different laterals will always be largely in common, they will also be largely independent. Extravagant use of water by a farmer on one lateral may not affect the welfare of another farmer on another lateral, but it does vitally affect the interests of every other farmer on the same lateral. An organization of all having this common interest to prevent waste and improve practice could accomplish much good. Such an association could also deal as a unit with the superintendent in the appointment of a ditch tender, and it is certain that any such organized cooperation would be welcomed by the superintendent. An association of users on a private sublateral could act intelligently in the employment of a water master or ditch foreman, who could receive the supply for the entire sublateral from the ditch rider on the main lateral and distribute it according to the rights of all and the rules of the association, subject, of course, to the general regulations of the district. Whether such associations are or are not formed, it is certain, if the most is to be made of the water, that the irrigators will have to take an active, intelligent interest in the problems of distribution and be ready to cooperate with the superintendents and ditch riders under them in a business-like, effective manner.

### CONCLUSION.

When grain growing yielded large returns, both in bushels and in money, and when the people were few and the areas large, bonanza farming in San Joaquin Valley was the best farming for both the land and the people because it was the only farming possible while this great valley was changing from a pasture to a farm. It demonstrated California's worth as an agricultural State and advanced her well up in the list of wheat producers of the country. The time came, however, when bonanza farming was no longer profitable, and when the natural opportunities of the valley could be most nearly taken advantage of by changing it from a 10-horse to a 2-horse country. This change took place, or is taking place, later in the sections covered by Modesto and Turlock districts than in some others in the valley. Its results, however, are already apparent even to the hurried traveler, whose eye can not escape the refreshing change from the homeless fields of growing grain or stubble of only four years ago to the 40-acre and 80-acre tracts of alfalfa, each with its plain but substantial farm house and barn, and its checks and lateral ditches. Intensive farming, with large returns from small areas, is taking the place of the soil exploitation of the past half century, and the people of these districts are face to face with an opportunity to create attractive and prosperous communities that will be a credit to themselves and to California. They have practically the first right to one of the best irrigation supplies in the State—a river that in almost any other irrigated section would be called upon to fill several score canals and ditches. They have soil that offers no more than the ordinary problems of culture and management, and a climate that is highly favorable to nearly every agricultural product California will be called upon to grow. But with these natural advantages they have serious responsibilities. By their own experience they must develop systems of management and cropping and rotation that will simultaneously, and without wasteful periods of fallow, yield rich harvests and conserve soil fertility; by seeing the evils of overirrigation they must learn the careful use of water; by slow and trying tests of canal and water management they must devise systems of water division and distribution that will insure each irrigator his just share of an ample supply. As more land is prepared for irrigation and more crops planted that will require a late water supply, reservoirs will need to be constructed on the upper waters of the Tuolumne, and the districts will be required to face the problems this additional supply will entail with the same resolution that was required in the building of canals and diversion works.

It is well for Modesto and Turlock irrigation districts that bonanza grain farming ceased to be profitable. So long as it was profitable the

better things that water and small areas and thrifty farmers would bring could not come. A few farmers had become rich by it, but many more were made poor and the towns were languishing. The gang plow and combined harvester had made the valley what it was, but if continued in operation they promised to bring about its ruin. It was therefore a distinct economic gain when large areas of grain land were included within the districts and made liable for taxes which the old style of farming would not justify. The breaking up of these areas is, of course, already under way, and with the present district organizations in operation it is inevitable that it shall continue until the average farm unit is 40 acres, or even less, rather than many times that, as in the past. It is natural, however, that there should have been decided opposition to any law or any organization that required a general water tax, whether water was used or not. It is also natural that farmers who once made fortunes in these districts without irrigation should even to-day be reluctant to learn the new lesson that irrigation requires. Nevertheless it is certain that advance has begun, and that this advance will be rapid or slow as the settlers in these districts learn how to use water carefully and effectively and how to stand by each other in dividing and distributing it.

#### **ACKNOWLEDGMENTS.**

In closing this report it is a pleasure to acknowledge the assistance and helpful suggestions of the officers of Modesto and Turlock districts, especially the superintendents, Mr. H. S. Crowe, of the former, and Messrs. B. W. Child and L. F. Hastings, of the latter. Mention should also be made of assistance rendered in the field by Mr. E. A. Gibbs, a senior student in civil engineering in the University of California, and of the help received from the ditch tenders in both districts in keeping canal records.

#### **FORMS FOR CANAL RECORDS.**

On recommendation of the irrigation and drainage investigations, the forms printed below have been adopted by Modesto irrigation district for keeping records of the diversion and use of water. Form No. 1 represents a page in the ditch tenders' record books and is designed for keeping track of the flow of water in the main canal and in the laterals. Form No. 2 represents one side of a mailing card for use in forwarding records of the flow in the main canals and laterals to the superintendent. Form No. 3 represents a page in the ditch tenders' record books and is designed for keeping a record of the delivery of water to users and of the daily work performed by the

ditch tenders. Form No. 4 represents the sheet to be used by the ditch tenders in forwarding to the superintendent weekly reports of water delivered and work done.

No. 1.

MODESTO IRRIGATION DISTRICT.

Record of gauge heights in \_\_\_\_\_ during month of \_\_\_\_\_, 190—.

Day.	Time.	Gauge height.		Day.	Time.	Gauge height.	
		Feet.	Tenths.			Feet.	Tenths.
1.....				17.....			
2.....				18.....			
3.....				19.....			
4.....				20.....			
5.....				21.....			
6.....				22.....			
7.....				23.....			
8.....				24.....			
9.....				25.....			
10.....				26.....			
11.....				27.....			
12.....				28.....			
13.....				29.....			
14.....				30.....			
15.....				31.....			
16.....							

Remarks: \_\_\_\_\_

No. 2.

MODESTO IRRIGATION DISTRICT.

Record of gauge heights in \_\_\_\_\_ for week ending \_\_\_\_\_, 190—.

	Month.	Day.	Time.	Gauge height.		Remarks.
				Feet.	Tenths.	
Sunday.....						
Monday.....						
Tuesday.....						
Wednesday.....						
Thursday.....						
Friday.....						
Saturday.....						

Under "Remarks" mention any unusual conditions, as "flood," "break in ditch," etc., and state how long water was out of ditch and when, if at all.

Forward this card promptly at end of week.

(Signature.) \_\_\_\_\_



No. 4, page 2.

Work done during week in addition to delivering water:

Sunday:

Monday:

Tuesday:

Wednesday:

Thursday:

Friday:

Saturday:

\_\_\_\_\_, *Ditch Tender.*

[Indorsement.]

MODESTO IRRIGATION DISTRICT.

\_\_\_\_\_  
Report of ditch tender on

.....  
for week ending \_\_\_\_\_, 190—.



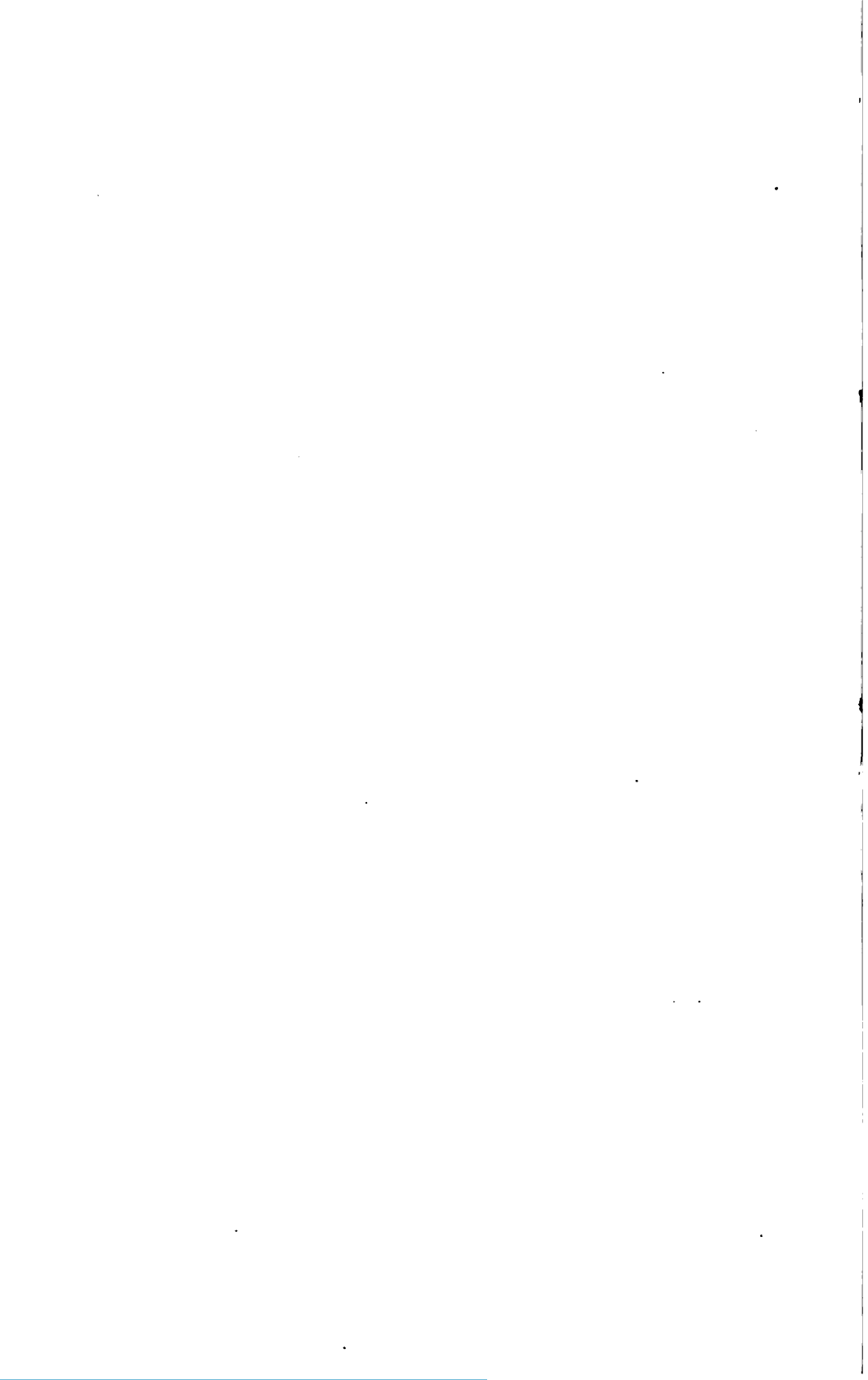

# RELATION OF IRRIGATION TO YIELD, SIZE, QUALITY, AND COMMERCIAL SUITABILITY OF FRUITS

By E. J. WICKSON,

*Professor of Agricultural Practice in the University of California and Horticulturist of the California Agricultural Experiment Station.*

## INTRODUCTION.

In earlier publications of the Department<sup>a</sup> the writer has endeavored to prepare useful statements of irrigation policies and methods from the point of view of the irrigator himself, securing the data by careful inquiry from the experience of several hundred irrigators in the Pacific coast States. These publications have been helpful to many beginners who have a strong liking for plain prescriptions and they have also had a certain interest to those conducting special investigations. It has seemed fitting to pursue the inquiry along the practical side one point further and draw from experienced irrigators their conclusions as to the effects of irrigation upon the commercial availability and value of fruits. The inquiry had the further object of securing practical suggestions for the assistance of beginners. The following questions were prepared with the idea of drawing out experience upon several lines of value and importance in commercial fruit production:

- (1) Can you give weight or measure of the product of a single irrigated tree or vine, or per acre? Compare with nonirrigated.
- (2) Is there any difference in regularity of bearing?
- (3) How do irrigated and nonirrigated fruits compare in size, flavor, aroma, and general appearance?
- (4) What has been your experience in shipping irrigated fruits, or in selling to shippers?
- (5) What has been your experience in canning irrigated fruits, or in selling to canners?
- (6) What has been your experience in drying irrigated fruits, or in selling to driers?
- (7) Has your irrigated fruit won prizes or awards at fairs or expositions? If so, when and where?

---

<sup>a</sup>Farmers' Bulletin No. 116, "Irrigation in fruit growing;" Farmers' Bulletin No. 138, "Irrigation in field and garden;" and Bulletin No. 108, Office of Experiment Stations, "Irrigation practice among fruit growers on the Pacific coast."

(8) Do you know of fruits or fruit trees or vines being injured in any way by irrigation? If so, in what respect?

These questions were sent to about 300 growers of irrigated fruits in the States of Idaho, Washington, Oregon, and California and to a number of shippers, driers, and canners who had used irrigated fruits in their trade or manufacture. The response from all the above-indicated interests was very satisfactory; a very free expression of belief and a very ample citation of experience were secured. It is the aim of this publication to deduce from this collection certain facts which seem to be clearly established by experience; to enforce them, where desirable for beginners in irrigation, with some account of the general principles which underlie them; to give due attention to responses which seem to contradict the prevailing conclusions on the same points and to account for the divergence of views by reference to different controlling conditions which give rise to it.

The citation of experience in condensed form will follow as closely as possible the exact wording of the writers, whose names are given. The geographical arrangement will be in general from north to south, as previously followed in Bulletin No. 108 (Office of Experiment Stations), to which the reader is referred for description of the irrigated areas and a map of the distribution of irrigation practice. That bulletin also introduces the names of many who have contributed to the present inquiry, and calls attention to interesting features of their irrigation and cultivation methods. In this respect this report may be regarded as supplementary to Bulletin No. 108.

#### QUANTITY OF PRODUCT AS AFFECTED BY IRRIGATION.

This is a matter which is really not in controversy in its general features, for there is a general disposition to credit irrigation with greatness of product; in fact this concession is often made with the view of denying its desirability—a question which will be discussed later. There is, however, a question newly broached and now commanding much attention, viz, how far is irrigation desirable in regions of considerable rainfall, or, in other words, how much water can a fruit tree or vine use to the profit of its owner? It is more clearly appearing each year, as Pacific coast trees become older, larger, and with greater bearing capacity, that more water is desirable than earlier in the life of the plant and that in the same locality some water in addition to an average rainfall, and much water in addition to an occasionally scant rainfall, make for the strength and capacity of the tree, which are manifested in the aggregate weight of the product. The recognition of this fact is carrying irrigation practice each year farther into the regions where the heaviest rainfall is received, which, on the annual rainfall figures alone, are called humid. Really, the districts in which

the advantages of irrigation are now most warmly discussed are the districts where a few years ago freedom from irrigation was gloried in, and in such districts the most striking instances of the commercial benefits of irrigation are to be found. The old contrast between the desert and the irrigated garden remains, of course, but it is accepted and admired in silence. The contrast which awakens most interest is that between the product of irrigation and that of rainfall where the latter was formerly held to yield all the water that could be desired. It requires a few more years of experience to multiply instances along this line, but they will be found ere long in great numbers in western Washington and Oregon and in northern California.

In the individual reports of observation on the influence of irrigation upon the volume of produce, all comments from strictly arid localities are omitted. Where it is manifestly impossible to grow fruit without systematic irrigation, the considerations which it is aimed to develop in this connection do not appear, because the use of irrigation is essential to any produce at all. The comments of correspondents upon the growth of berries and of citrus fruits are also largely eliminated because the shallow rooting of the former and the evergreen growth of the latter render both dependent upon irrigation during the long, dry season to a degree beyond any requirement of deep-rooting deciduous fruit trees and vines. The following excerpts from correspondence then apply to localities where it is quite possible to grow the fruits, at least on some soils, with some degree of success, without irrigation, so that comparison with adequate use of water can be made:

## IDAHO.

W. G. Whitney, Payette: The weights of single fruits by irrigation are increased about 10 per cent and the crops about 50 per cent.

L. A. Porter, Porters: I have kept no account of unirrigated trees, as neither the growth nor the fruit was such as to excite admiration.

## WASHINGTON.

C. Robinson, Chelan: Trees here are planted close, say 16 to 20 feet each way. As they get large the number must be reduced unless irrigation can be had.

A. L. Graham, Anacortes: No fruits are grown by irrigation as yet, but probably all would be benefited in dry seasons, especially apples and pears during August and September.

Jason Whinery, Spokane: I can not irrigate my land, but most of it would be greatly benefited by it.

## OREGON.

Seufert Brothers, The Dalles: I have picked 500 pounds of fruit from a Royal Ann cherry tree 12 years old. Without irrigation it would not yield a pound, as it is on dry soil.

W. Dimmick, Hubbard: Not much irrigation is needed in the Willamette Valley, though it might be used to some advantage.

Ray C. Brown, Roseburg: The prevailing opinion of fruit growers in this section is that deciduous fruits need no irrigation. For myself, I am of the opinion that the

moisture retained in the soil during the protracted drought of July, August, and September would easily admit of supplement by judicious irrigation.

A. H. Carson, horticultural commissioner, Grants Pass: There is not a 40-acre tract of land in Josephine County on which an abundance of water can not be had by digging wells, and with cheap gasoline or electric power it is profitable to dig the wells and use the water. Especially is this true when it is known that one acre, intelligently handled with water to irrigate with, will, during a year, produce ten times as much as without. To illustrate, Olwell Brothers, of Central Point—commercial apple growers—have made a success growing apples without irrigation. These successful men do not allow themselves to drift—they keep on doing things. As an experiment, last year, in their orchard at Central Point, they put in a gasoline pumping plant, which cost them for well and gasoline engine and gasoline for the season, \$720. They irrigated 100 apple trees and last fall sold the apples from their irrigated trees for \$1,100—\$380 more than their plant cost them. Without irrigation, these 100 apple trees, owing to the very dry season and the very dry ground where they were situated, would not have matured a dollar's worth of marketable apples.

CALIFORNIA.

Owen Daily, Whitmore, Shasta County: I can not give weight or measure, but I believe irrigated trees produce twice the amount of fruit that can be had from non-irrigated trees and of better quality.

W. E. Whitmore, Whitmore, Shasta County: Mr. W. A. Smith owned a dry ranch 10 miles from Millville, at an elevation of 1,200 to 1,500 feet, the soil rocky, a clearing of blue oak and digger pine. He had early grapes, but Muscats did not mature. He secured irrigation water, and since then has had good Muscats also.

George A. Lamiman, Anderson, Shasta County: The yield of good-sized trees by irrigation will be about 200 pounds of fruit, while nonirrigated trees will yield from 40 to 50 pounds.

George H. Flournoy, Corning, Tehama County: Thomas White, of Richfield, gathered in 1903 from 50 to 60 pounds of peaches from trees planted in dormant bud in 1900. Nonirrigated trees of the same age bear nothing. There are some lands in this section upon which fruits do well without irrigation, but I do not know of any that would not be benefited both in quality and quantity of products by the proper use of water.

W. E. Hazen, Manton, Tehama County: I have picked and weighed a ton of apples from one irrigated tree. Prunes do about the same. Nonirrigated trees do about one-half as much.

J. L. Barham, Manton, Tehama County: Irrigated apples are large (16 to 22 ounces) and plenty of them. Irrigated prunes run mostly 40 to 50's and 50 to 60's.

G. M. Gray, Chico, Butte County: I am satisfied I have doubled my fruit crops by irrigation.

Rio Bonito Orchard Company, Biggs, Butte County: Irrigation is the life of prune trees. In our experience, when over half a mile from a river, irrigation has increased the size of the trees about 30 per cent and the crop about 100 per cent. Since commencing irrigation I have never had a failure of the prune crop, regardless of years of drought and other causes. Prunes have yielded 12.6 tons to the acre, green weight. Cling peaches 6.5 tons to the acre of 2½ inches in diameter (cannery size) and clean fruit. Pears, unirrigated because out of the reach of water, are an uncertain crop.

A. D. Cutts, Liveoak, Sutter County: We have determined that to get the best results with deciduous fruits we must keep moisture at the roots of the trees from the time they start growth until the fruit is picked. There is no question in my mind as to the value of irrigation to this end, as we have grown larger peaches than before, while most growers who do not irrigate get very small fruit.

C. E. Burns, Fulton, Sonoma County: From what I see of orchards in this county I am sure that the trees are suffering for lack of moisture and would be greatly benefited by irrigation. Some of the trees have light crops, but still do not look as healthy and vigorous in leaf and shoot as they should.

E. W. King, Ukiah, Mendocino County: Two great dangers of fruits here are, first, frost; second, hot weather in July and August, which burns the fruit. The latter, I believe, would be obviated by irrigation, and the quality and quantity of the fruit much improved.

A. E. Burnham, Healdsburg, Sonoma County: I have an early cherry tree which, after bearing three or four years, began to die back. The leaves would droop and wilt soon after the fruit was ripe. I had a well sunk close to it for my windmill and 3,000-gallon tank, for house and barn use. More or less water was thrown around the tree and it started to recover, and has borne several crops of better fruit, and to-day it is perfectly healthy. All it has had has been plenty of water in the dry season. I have 4 cherry trees in my dooryard, and in 1903 apparently every bloom stuck, and about the time the fruit should begin to swell out the cherries looked as though they would be good for nothing; but I ran water from the tank by tons until I had the ground soaked deep. The fruit began to swell out and the leaves brighten, and the result was I sold nearly \$40 worth of fruit for canning from 4 trees.

John T. Harrington, Colusa: I have grown oranges weighing 78 pounds to the box by irrigation and a thorough system of cultivation.

T. J. Wagoner, Rough and Ready, Nevada County: From 3 irrigated Crawford peach trees I have picked 40 boxes of fruit. The average of the orchard was 8 boxes per tree (20 pounds per box), and they sold at 50 cents per box.

P. W. Butler, Penryn, Placer County: Fruits can be grown without irrigation, but it is absolutely obligatory in this region that they have irrigation if grown for profit.

W. R. Fountain, Newcastle, Placer County: My 780 cling peaches (irrigated) have yielded from 53 to 70 tons of canners' size fruit, and are cropped every year.

F. B. McKeivitt, Vacaville: I have known a single irrigated 2-year-old peach tree unpruned and the long growth staked up to produce 200 pounds of peaches.

W. J. Pleasants, Winters, Yolo County: We have in Pleasants Valley about 25 inches of rainfall upon an average each year. I do not believe we need irrigation here for growing fruit because of the heavy clay subsoil which prevents the water from escaping from below. On the other hand, any soil that has a gravelly or sandy subsoil can be greatly benefited by irrigation because the rainfall in the winter goes through and leaves the tree roots dry. Land with this gravelly or sandy subsoil should have water in spring and summer to get the best results. A great deal of the soil of the Sacramento Valley has such subsoil and shows the want of summer irrigation. In many places irrigation would double the production and value of the lands.

Edgar J. De Pue, Yolo, Yolo County: We are fully satisfied that without irrigation our crop would virtually have perished during the past few years. We have 500 acres and aim to irrigate the whole of it. We have found water particularly beneficial to almonds, assisting the development of the hull as well as the kernel and preventing "sticktights."

Charles W. Landis, Folsom City, Sacramento County: The early varieties of deciduous fruits are not irrigated here, and plums and prunes seem to mature without irrigation. No satisfactory results have been obtained from irrigating almond trees. Peaches and grapes are irrigated, though all these fruits will grow and come to maturity without water yet the net results usually pay more than the expense of irrigation.

William Johnston, Courtland, Sacramento County: Twice in my life I thought it best to irrigate peach trees, and these times were two dry years twenty years apart.

At these times the water applied proved of great value, but ordinarily I do not think we need irrigation.

Vital E. Bangs, Modesto, Stanislaus County: I know of but one orchard here that has yielded fair crops without irrigation and that is an olive orchard half a mile north of Modesto, but even this orchard could be made to increase its yield by irrigation.

A. J. Heese, Merced, Merced County: I have irrigated peach trees seven months from planting which are larger than the average of 4-year-old trees planted on an adjacent dry land and grown without irrigation.

W. S. Shelly, Hollister, San Benito County: On land short of natural moisture irrigation will increase production from 10 to 20 per cent.

Charles Downing, Armona, Kings County: My pear orchard is subirrigated by seepage from the main ditches. There are two or three spots where the ground is higher than the average of the orchard on which the trees are not of as vigorous growth nor do they yield fruit of the same value as the average trees of the orchard. In my peach orchard a sand streak is noticeable by failure of trees to grow, probably because the streak will not hold the water.

Frank Femmons, Ahwalnee, Madera County: I have weighed 80 pounds as the product of a single irrigated grape vine and estimated 5 tons on one-half an acre.

H. J. Dennison, Nordhoff, Ventura County: The soil of the Ojai Valley is very deep and rich, and with good winter rainfall and spring rains we can grow very good fruit without irrigation. I have, however, a few fruit trees near a water tank, which have been irrigated, and their product is larger and the fruit finer and larger than unirrigated trees. I believe irrigation would much improve the product, and in dry years would perhaps double it.

E. S. Thacher, Nordhoff, Ventura County: I am now beginning to irrigate a large olive orchard, being satisfied that in this locality olive trees can not be made to bear heavily without water after they have gained considerable size.

Robert Dunn, Fillmore: By my experience in Ventura County I found that irrigated apricot trees averaged 300 pounds per year for five years, while other trees of the same age in the same soil, but not irrigated, did not average 100 pounds per tree.

P. F. Cogswell, Elmonte, Los Angeles County: My English walnut trees (on sandy loam, 25 feet to water) are vigorous and thrifty, showing large new growth each year and well-filled nuts of good weight. In other orchards on equally good soil and other conditions the same, but not irrigated, or so little water used as to be practically useless to a walnut, the trees show little or no growth, much dead wood in the tops, and nuts small and not well filled. In another situation a 12-year-old walnut orchard, unirrigated, yielded less than \$20 per acre, while irrigated orchards of the same age yielded \$100 per acre, and the unirrigated trees of 12 years old are no larger than irrigated trees at 5 years of age.

H. D. Briggs, Azusa, Los Angeles County: I have always irrigated, as I knew the returns would not be satisfactory if I did not. I have picked 1,000 pounds of apricots from one tree.

Henry D. Engelhardt, Glendora, Los Angeles County: A tree or vine properly irrigated will bear 50 to 100 per cent more fruit than one which has no irrigation.

James Boyd, Riverside: I have a small family orchard of deciduous fruits which has been irregularly irrigated with waste water, but not irrigated from July to September. This year the irrigation has been regular and thorough, and the trees and fruit are in better shape than ever before, apples especially. The trees have much better foliage, are making a better growth, and the fruit is better developed.

J. H. Reed, Riverside: We had considerable mixed plantings of deciduous fruits with oranges, and used plenty of water, but judiciously. Our trees were in bearing much earlier than adjacent nonirrigated trees—in fact, paid for the planting and care

of the citrus trees up to the time the latter began bearing. This was a great saving, not to speak of the increased crops later.

I. Ford, Redlands: Apples can be grown in the mountains at 5,000 feet elevation without irrigation by careful cultivation, but with a full crop the fruit is much finer and larger with irrigation. Ten-year-old apple trees will yield 10 tons per acre with a fair crop. My Ben Davis apple trees, planted in 1899, averaged 40 pounds per tree in 1903, 4,800 pounds per acre, as the trees are planted 15 by 20 feet, with expectation of thinning the trees when older. This would not be possible without irrigation, as in that case the trees ought to be planted not closer than 30 by 30 feet; in fact, an apple grower at Julian, not using irrigation, says he would plant apple trees 50 by 50 feet, as they bear so much better. The difference in production of 120 trees or 20 trees per acre for the first five years of bearing will pay for the orchard many times over, and this is made possible by irrigation.

W. S. Corwin, Highland, San Bernardino County: Irrigated trees give 25 per cent more fruit than unirrigated.

C. A. Walter, Independence, Inyo County: My experience of forty years convinces me that the best way to raise fruit is by irrigation.

R. Egan, Capistrano, Orange County: With full-bearing English walnut trees, 30 trees to the acre, the yield for several years has been 125 to 135 pounds per tree.

A. S. Bradford, Fullerton, Orange County: The yield of peaches, apricots, and apples has been fully one-third to one-half greater with irrigation, and the fruit is larger.

D. Edson Smith, Santa Ana, Orange County: In a few localities, where the soil is of such nature that it persistently retains its moisture, apricots may be grown to perfection with proper cultivation when we have an unusual amount of rain, but as a general proposition irrigation is necessary in order to secure the best fruit.

H. Culbertson, El Cajon, San Diego County: It is safe to say that an orchard irrigated from the first, compared with one not irrigated, will yield five times as much fruit at 5 years old. The difference for grapes would not ordinarily be so great. Peaches at 8 years old, under proper treatment, will yield an average of 300 pounds of marketable fruit to the tree. I have done this and know of others who have done better. Well-irrigated raisin grapes with me have produced 2 tons of raisins to the acre, where one-fourth that amount would have been a good yield without irrigation.

Lewis E. Kent, Poway, San Diego County: There is no doubt about the desirability of irrigation, as one can easily see the increased crops by irrigation, grapes and olives especially.

It is very significant that there is such unanimity in favor of irrigation, although many of the growers, whose conclusions are quoted above, are situated in districts having considerable rainfall. It is notable that, in fact, no reports denying the efficiency of irrigation in increasing the product of trees and vines were received, although there are, manifestly, conditions under which irrigation is not essential to the fullest service of the fruiting plants and therefore hardly worth providing. Correspondents, however, did not consider this point worth making in their reports. This clearly indicates a change in the public mind with respect to irrigation in fruit growing and betokens full recognition of its importance. A few years ago objections to irrigation as either unnecessary or undesirable, or both, would have been urged by scores of correspondents when offered such an opportunity as this inquiry placed before them.



### REGULARITY OF BEARING AS AFFECTED BY IRRIGATION.

This subject has only recently risen to its proper place in the discussion of fruit-growing policies on the Pacific coast. The declaration of the principle on which regular production rests that the fruiting plant requires moisture for two distinct functions during its active season is not new, but the appreciation of its truth and practical bearings is recent. It has been forced upon the attention by investigations at the Wisconsin Experiment Station,<sup>a</sup> showing that the tree, in certain cases at least, was devoting energy to the development of the fruit buds for the following year and carrying the burden of the current crop at the same time. It was known that the tree forms fruit buds in the later months of growth after its fruit may have matured, but the announcement of the earlier undertaking of this function strongly emphasizes the necessity of ample moisture supply, not alone for the current crop but for the succeeding crop. For this reason an effort was made in this inquiry to secure facts from wide observation as to the relation of irrigation to regularity of bearing. Formerly recourse was had to pruning to lessen amount of bearing wood and reduce the burden of the tree after the fruit had set. The newer idea is to supply water to enable the tree to carry more fruit to satisfactory size and at the same time to prepare for the following year. In fact the relation of adequate moisture to the strength and effectiveness of the fruit bud has come to be widely appreciated. The following are the views of growers upon these points:

#### IDAHO.

A. McPherson, Boise: Irrigated trees bear more regularly.

L. A. Porter, Porters: I do not think there is any difference in regularity of bearing.

#### WASHINGTON.

F. E. Thompson, North Yakima: Irrigated fruits bear more regularly in this locality.

J. H. James, Waitsburg: My experience is that there is not much difference in regularity of bearing.

#### OREGON.

Seufert Brothers, The Dalles: Irrigated are surer to bear because growth is later on soil filled with cold water, and the bloom is delayed until after early spring frosts are over. We never miss a crop.

J. R. Casey, Ashland: Regularity of bearing is in favor of irrigated trees.

#### CALIFORNIA.

Owen Daily, Whitmore, Shasta County: Irrigated trees will bear more regularly.

George A. Lamiman, Anderson, Shasta County: Irrigated trees are more regular in bearing.

O. E. Graves, Redbluff, Tehama County: Irrigated prunes are more regular in bearing.

<sup>a</sup> Annual Report for 1899.

Fred Scharr, Redbluff, Tehama County: Irrigation after fruit ripens, to keep the buds growing for the next year, insures regularity of bearing.

George H. Flournoy, Corning, Tehama County: After twenty years' experience, I am perfectly assured that irrigated trees are much more regular in bearing.

W. E. Hazen, Manton, Tehama County: Apple trees will bear every other year. If they bear a full crop one year they will not bear the next. Prunes will bear regularly every year.

J. L. Barham, Manton: Irrigated trees are far more regular in bearing.

G. M. Gray, Chico, Butte County: One corner of my peach orchard that was not irrigated last year has this year less than half the crop per tree that is seen upon the part that was irrigated. This is clearly to be seen. I need no better demonstration. The maturing of the pits of the current crop, the girth of the wood, and the development of fruit buds for the following year are going on in midsummer and are a great draft upon the tree. The development of the coming buds seems first to suffer when moisture is scant. I have found that giving fruit trees and vines on valley land a good irrigation from June 15 to July 15 will very materially help both the present and coming crop.

Rio Bonito Orchard Company, Biggs, Butte County: Irrigated fruit trees are more regular in bearing.

G. W. Thissell, Winters, Yolo County: Many orchards fail to produce a good crop of fruit annually for want of sufficient water. The fruit is poor and insipid and the trees are not able to mature fruit buds for the following year. I recently visited as fine a Muir peach orchard as there is in the State—on the choicest of fruit land on Putah Creek. Trees which had been given a little water were bending to the ground with large fruit, while the trees with no irrigation had wilted leaves and peaches the size of walnuts, and yet the trees were on the best of land. The fruit was too small to cut for drying and the trees will have no fruit next year.

E. A. Gammon, Courtland, Sacramento County: Regularity of bearing is on the side of irrigated trees. Irrigated pears are not so apt to fall; the stems seem to have more life in them.

W. W. Hinsey, Fair Oaks, Sacramento County: In regular bearing there is a large difference in favor of irrigated trees.

Charles W. Landis, Folsom City, Sacramento County: I have never noticed any difference in regularity of bearing.

F. B. McKeivitt, Vacaville, Solano County: Irrigated trees bear more regularly.

H. T. Fuchs, Grass Valley, Nevada County: My observation is that irrigated trees are more regular in bearing. Fruit trees and grapevines will not produce good fruit in this section unless they are irrigated or highly cultivated.

P. A. Butler, Penryn, Placer County: Irrigation insures much more regular bearing.

W. R. Fountain, Newcastle, Placer County: Many orchards are rented to Chinese and others who object to taking pains to irrigate after the fruit is picked. For this reason the early fruits get less irrigation than the later varieties. It seems to be a fact that irrigation after the fruit is picked is making good regular bearers of the Alexander and Hale early peaches which have been disposed to drop their buds just prior to blooming and to drop the fruit while small.

J. W. Violet, Ione, Amador County: Irrigated orchards appear to bear more regularly.

A. E. Burnham, Healdsburg, Sonoma County: I know that old Sonoma County, that boasts of nonirrigated crops, could make hundreds of thousands of dollars more from her orchards if the waste waters were properly used in July and August. The trees would live longer and bear more regularly, for the new wood and especially the buds would be strong and well matured for the coming year. I do not mean to drown the trees, but one irrigation, or at most two, is enough in this county if the

ground is thoroughly soaked and, when dry enough, cultivated to mellowness and fineness.

A. Block, Santa Clara, Santa Clara County: I believe irrigated fruit trees bear more regularly.

F. M. Righter, Campbell, Santa Clara County: Regularity of bearing and plenty of moisture go together.

H. Hoops, Wrights, Santa Clara County: If intelligently applied, irrigation makes trees more regular in bearing.

W. S. Shelly, Hollister, San Benito County: I have not noticed any difference in the regularity of bearing.

W. T. Kirkman, Merced, Merced County: Irrigated fruit trees are more regular in bearing.

Dr. W. N. Sherman, Fresno, Fresno County: The olive trees along or near irrigation ditches show a marked superiority to those without access to water.

E. S. Thacher, Nordhoff, Ventura County: I had a few acres of apricots, prunes, etc., but found them unprofitable because I was not prepared to irrigate them.

C. C. Teague, Santa Paula, Ventura County: While it is possible to grow fairly good products from young orchards without irrigation it is simply out of the question when the trees get older. Many growers in this county used to think when their deciduous trees began to go back when they were 10 or 12 years old, that it was on account of old age. This was before they began to irrigate. Since then it has been demonstrated beyond doubt that the trouble was not in the trees, but in the fact that the water in the subsoil became exhausted after a number of years and the annual rainfall not being sufficient to wet the ground down to a depth of more than 4 or 5 feet the lower roots were in dry earth and consequently could not help to support the tree. It is now the universal belief that it does not pay to set out an orchard in this valley unless one has water for irrigation. It makes little difference with the deciduous trees on deep soils whether the water is put on during the winter or the summer, but most growers prefer the former, when the trees are dormant.

F. F. Stetson & Co., Los Angeles: We heartily favor irrigation, believing that the trees bear more fruit and with greater regularity—that is, there are fewer seasons with short crops.

H. D. Briggs, Azusa, Los Angeles County: With irrigation properly applied and fertilization, trees will bear every year unless unfavorable temperatures prevail. By irrigation the tree is enabled to overcome the exhaustion of heavy bearing and to fill out the buds for the next year's fruiting so that the fruit will "stick" instead of blasting.

Henry D. Engelhardt, Glendora, Los Angeles County: The irrigated tree and vine will produce fruit more regularly.

William Chappelow, Monrovia, Los Angeles County: Nonirrigated fruit trees are very irregular in bearing with us.

N. E. Chesebro, Covina, Los Angeles County: There is a great difference in regularity of bearing in favor of irrigated trees.

J. W. Mills, Ontario, San Bernardino County: Until the last two years our almond trees would only bear during the most favorable seasons. They had received some irrigation since planting, but only during the last two years have we given them water enough to keep them growing while they were maturing a crop of nuts. Both years they have grown good crops. The more liberal irrigation has made them grow large nuts and a growth of new wood at the ends of the branches (not suckers) from 6 inches to 2 feet in length. This seems to insure regular bearing, even though the temperature on three days in February and while the trees were in full bloom fell to 24°, 27°, and 25° and three days following reached 28° and 30° F.

I. Ford, Redlands, San Bernardino County: Trees are earlier and more regular in bearing when kept thoroughly irrigated and cultivated.

W. S. Corwin, Highland, San Bernardino County: Regularity of bearing is decidedly on the side of irrigated trees.

James Boyd, Riverside, Riverside County: Crops on irrigated trees are better in every way.

L. L. Bequette, Whittier, Los Angeles County: There is no difference in regularity of bearing.

J. B. Neff, Anaheim, Orange County: I have always had a crop of English walnuts on irrigated trees, while others have had but a small unprofitable crop.

A. S. Bradford, Fullerton, Orange County: The yield is regular when water is used, otherwise there are off years. By irrigation in the summer the formation of fruit buds for the next season's crop is promoted.

James W. Hyne, San Marcos, San Diego County: When irrigated and kept in a thrifty condition fruit trees bear more regularly.

Chester Gunn, Julian, San Diego County: Irrigated trees bear more regularly.

H. Culbertson, El Cajon, San Diego County: There is a decided difference in the peach, especially in the shy-bearing varieties and late irrigation is what produces the results.

C. A. Walter, Independence, Inyo County: There is much difference in regularity of bearing; the irrigated tree is always in trim to bear, is healthier and leafs out earlier.

These reports present a vast preponderance of observation and experience that irrigation does promote regular annual fruit bearing. There are a few instances in which the opposite view is expressed and others in which the observer is in doubt. In some cases probably the opposing observation rests on experience in situations where trees are not helped in regularity of bearing by irrigation because they really have a greater amount of available moisture, though the rainfall may not be greater, than is available on adjacent places where the contrary observation is made. This is strikingly true in the case of Whittier, Los Angeles County, Cal., where Mr. Bequette reports regular bearing without irrigation. Whittier is a low-lying region with great depth of soil and ground water within reach of deep-rooting trees. In such a situation irrigation is naturally less likely to be profitable, because the trees are supplied by the underground movement of water and enjoy more than their share of the scant rainfall of the district. There may be similar conditions to explain the conclusions of the few others who hold a negative view.

### QUALITIES AND COMMERCIAL CHARACTERS OF IRRIGATED FRUIT.

The desirability of irrigated fruits, for qualities which appeal to the fruit eater and for characters which win the fruit trade, has long been in controversy, and the prejudice against irrigation from these points of view has been most outspoken. This prejudice still exists in the minds of those who have not had opportunity for careful comparative judgment and no experience to distinguish between properly irrigated and excessively irrigated fruit. Of course, theoretically the

best fruit must come from the tree which has moisture continually present during its growing period in the amount required for perfect development of its fruit. Too little water for such perfect growth would injure the fruit and too much water would also injure it, and although the injuries proceeding from lack and from excess might be different, they would all render the fruit defective. But there have been prejudices against irrigated fruit which have been slow to disappear even among fruit growers, who might be presumed to have the best opportunities for speedily reaching sound judgments on the matter.

The first striking character of irrigated fruit to attract attention was unusual size, and such size was often found to be unmatched by richness and flavor. Medium-sized fruit was better to eat. The general conclusion then was that water artificially applied made a fruit fine to look upon but not otherwise desirable, and from this single observation arose the quite general opinion that the farther it departed from largeness the better the fruit; therefore the smaller the fruit the richer in sugar and the more refined the flavors and aroma. It is difficult to replace this opinion by urging theoretical considerations of the actual need of the plant for a continually adequate moisture supply, nor do the determinations of sugars and essences by fruit analysts nor the awards of exposition juries convince all whom they reach. It seems desirable then to cite general experience of those who judge fruits by ordinary sense methods or by commercial standards in order to determine whether such experience reinforces the conclusions reached by those who approach the problem along lines popularly distinguished as "scientific." This was the motive in the inquiry upon which this report is based.

The attempt was made to secure the results of the experience of fruit growers, some of whom could give comparative judgment and others of whom perhaps had grown only irrigated fruit and could speak positively from experience as to its suitability for various commercial purposes. Although the writer was aware of the general change in the mind of growers toward the use of water even in regions of considerable rainfall, he must acknowledge that the declaration of the benefits of irrigation in developing desirable qualities in fruit is sharper and wider than expected and there can be no question as to the impression and influence which will follow the publication of the testimony here presented.

#### IDAHO.

A. McPherson, Boise: Irrigated fruits are the best in every respect.

L. A. Porter, Porters: Irrigated fruit is superior in every way. In fact, without irrigation it is hard to always get moisture enough to bring the fruit to perfect maturity, hence it lacks in size, flavor, and general appearance. I consider it almost impossible to produce perfect cherries, peaches, or pears in an unirrigated orchard.

They always lack the size, color, and rich flavor that comes to a perfectly irrigated fruit. I have noticed that young unirrigated trees bearing few fruits will mature them, while in a year or two, while the trees are more heavily loaded, the fruit will be small and lacking in flavor.

W. G. Whitney, Payette: Irrigated fruits are much larger, more juicy, and much nicer looking.

## WASHINGTON.

E. H. Libby, Clarkson: Our fruits are all irrigated. On the higher lands, from 1,500 to 2,000 feet above our level, the apples are about half the size of ours. That fruit rightly irrigated and thoroughly cultivated is fully as good as a like variety grown without irrigation is the experience of the writer, which has extended over much of the United States and Canada.

Jason Whinery, Spokane: Irrigated fruits are better in every respect if the land is dry and the rainfall short. Some years there is no need for irrigation here.

F. A. Huntley, North Yakima: I consider properly irrigated fruits superior in every respect. I find irrigation in July to stimulate and prolong the growing period. Nonirrigated sections often lack sufficient moisture in midsummer to mature the fruits.

F. E. Thompson, North Yakima: Irrigated fruit is larger and better in appearance and as good in flavor as unirrigated.

Chas. S. Simpson, North Yakima: Irrigated fruits are better in every respect than unirrigated.

J. H. James, Waitsburg: Irrigated fruits are a great deal better in size and nicer in every respect.

## OREGON.

S. A. Miller, Milton: Irrigated fruits are larger and the flavor is usually as good, sometimes better. This is especially true when the nonirrigated fruit does not get sufficient moisture.

R. H. Weber, The Dalles: I have noticed that irrigated fruit is apt to be larger than that grown without irrigation; flavor, aroma, and general appearance would, however, be in favor of the latter.

Seufert Brothers, The Dalles: Irrigated fruit is 100 per cent better, but water must be used with judgment. Do not irrigate on extremely hot days; do not swamp your land and cause it to bake.

J. R. Casey, Ashland: Irrigated fruit is much nicer in every respect.

## CALIFORNIA.

W. E. Whitmore, Whitmore, Shasta County: J. H. Whitmore, at 2,000 feet elevation, on a slope facing southwest and on a little flat at its base, raises very fine table grapes of various kinds, but is extremely careful to give very little water. P. Guttman, altitude 2,600 feet, has beautiful Muscat and Black Hamburg grapes, but as he kept water on nearly all of the time they were about as sweet as a lemon. Properly watered, he found they improved in flavor.

Owen Daily, Whitmore, Shasta County: Irrigated fruits are much larger, better flavored, and finer looking.

George A. Lamiman, Anderson, Shasta County: Irrigated fruit is double the size and is beautiful in color and splendid in flavor, while nonirrigated is rather dry and insipid and lacking in color.

Fred Scharr, Redbluff: Properly irrigated fruit will be one-third larger. Nonirrigated fruit will be more aromatic and better flavored, but the large size the market calls for must be secured even at the expense of quality.

O. E. Graves, Redbluff: Irrigated prunes are much larger.

Mrs. Emma E. Yager, Manton, Tehama County: Irrigated fruits mature better, and if properly irrigated are fine in flavor and appearance.

W. E. Hazen, Manton, Tehama County: Irrigated fruit is larger and has better flavor and general appearance. Irrigated apples color better.

J. L. Barham, Manton, Tehama County: Irrigated fruits are far better than non-irrigated in every way.

George H. Flournoy, Corning, Tehama County: My experience is that irrigated fruit is superior in every respect.

G. M. Gray, Chico, Butte County: Irrigated fruits are at least 30 per cent better in all respects.

Rio Bonito Orchard Company, Biggs, Butte County: Irrigated prunes are better in every way. Irrigated peaches are larger and handsomer, but in flavor and aroma they are inferior in freestone peaches and to a less degree in clings.

L. F. Moulton, Colusa, Colusa County: Irrigated fruit is much larger, equally as fine in flavor and aroma, and excellent in general appearance.

C. A. Thomas, Woodland, Yolo County: The character and quality of our fruits are improved by irrigation. The almond in every way is benefited, and adjacent orchards show the advantage of irrigation over nonirrigation with equal cultivation.

Edgar J. De Pue, Yolo, Yolo County: We are irrigating 500 acres of fruit trees. We have found that the fruit on trees along the ditches which received more water than the average was of better quality, and matured and kept better than that from trees which had less water.

G. W. Thissell, Winters, Yolo County: There is no comparison in size and quality between irrigated and nonirrigated fruit when the trees need water. If there has been a series of wet years, some orchards will need no irrigation, but others on different soil will require irrigation at the proper time.

F. B. McKevitt, Vacaville, Solano County: Irrigated fruit is larger, equally handsome, and has the same aroma, but the flavor is not so fine as the unirrigated.

Foster Brothers, Dixon, Solano County: Irrigated fruits are far superior.

E. A. Gammon, Courtland, Sacramento County: Irrigated fruit is much better in size, flavor, and general appearance.

Charles W. Landis, Folsom City, Sacramento County: The irrigated fruits have better size, flavor, aroma, and general appearance.

T. J. Wagoner, Rough and Ready, Nevada County: Irrigated is more than twice the size of nonirrigated, and the amount of the crop is twice as great. The nonirrigated fruit lacks in flavor.

H. T. Fuchs, Grass Valley, Nevada County: Irrigation improves both size and flavor if it is not overdone.

Felix Gillet, Nevada City, Nevada County: My experience is that in the mountains vastly finer fruits and nuts are grown by regular irrigation to the amount available by the natural retentiveness of the soil. In some soils several good soakings, especially in June or July, may be enough, though more frequent irrigation, say once a week for ten weeks or more on soils not retaining moisture well, may be even more beneficial. Irrigation of both tree fruits and grapes should stop as soon as they have attained three-fourths to four-fifths of their size to allow them to acquire flavor. I have a Winter Royal pear tree, 33 years old, the largest of my collection, which bears 1,000 pounds of pears, which keep until April or May and then ripen. The fruit is medium sized and very juicy without being irrigated. A friend planted a tree of the same kind in a clover patch, where water was run continually and four or five crops of clover cut. This tree grew finely, bearing large crops of pears twice the size of mine, but ripening about December. With other pears I find that irrigation improves them very much in size and general appearance, but winter kinds seem to lose keeping quality if irrigated unless it is done moderately and stopped rather early in the season. The difference between irrigated and nonirrigated fruits,

as far as size and general appearance are concerned, is remarkable, though I admit that in certain rich and deep soils, naturally moist, as fine fruit can be grown without irrigation as on dry shallow soils with it. I find that nuts of all kinds are also much improved in size if properly irrigated, and if irrigation is stopped when the nuts have pretty nearly attained their size the quality will not be impaired. Filberts are immensely benefited by irrigation. Irrigation makes the peach more juicy, which is a decided gain. Compare a juicy peach with one that is dry and mealy—what a difference.

P. W. Butler, Penryn, Placer County: Irrigated fruit is much larger, of better flavor and aroma, and generally better looking.

W. R. Fountain, Newcastle, Placer County: Irrigated fruit is larger and prettier and is all right to eat.

A. E. Burnham, Healdsburg, Sonoma County: I had twenty-five years' experience in growing fruit and vegetables in Utah, where I had to depend on irrigation, and I raised as fine peaches, plums, and pears and better apricots than I have ever raised since coming here, both in size and flavor, and I have had as good as any seen around here.

John Rock, Niles, Alameda County: The character of the fruit depends upon how the irrigation is done. The use of too much water will swell the fruit at the expense of flavor.

Edward M. Ehrhorn, Mountainview, Santa Clara County: I can see a great difference in quality and flavor of irrigated fruits if not too much water is used.

A. Block, Santa Clara: Irrigated fruits are larger and better, particularly if properly fed when required. My trees are 40 to 50 years old.

S. P. Sanders, Cupertino, Santa Clara County: At the West Side Drier the manager declares in favor of nonirrigated fruits on the ground of flavor, aroma, etc.

J. H. Flickinger Company, San Jose: Irrigated fruits are better in size and general appearance, but not as good in flavor.

F. M. Righter, Campbell, Santa Clara County: Irrigated fruits are larger, more acid, and of superior appearance. I have not detected any difference in aroma.

H. Hoops, Wrights, Santa Clara County: Irrigated fruits are larger, but they have less flavor and the general appearance is not so good. Some fruits will bear heavier irrigation than others.

W. S. Shelly, Hollister, San Benito County: Flavor and appearance are not hurt by winter irrigation and size is increased.

W. W. Hinsey, Fair Oaks, Sacramento County: Irrigated fruits are better in every respect.

J. W. Violett, Lone, Amador County: The size and general appearance of fruits is greatly improved by irrigation, and that is the principal point to be gained for the grower.

J. M. Harris, Miami, Mariposa County: Irrigated fruit has better color and finer appearance and just as good flavor as nonirrigated. All kinds of fruit must have a certain amount of moisture, natural or artificial.

Frank Femmons, Ahwahnee, Madera County: Irrigated fruits are better developed in all their qualities if water is used with good judgment.

C. A. Walter, Independence, Inyo County: Irrigated fruit is twice the size, is sweet, and of the finest flavor.

N. J. Cooley, Bishop, Inyo County: Irrigated fruits are generally larger, but if irrigated when ripening the flavor is injured, especially in the case of winter apples.

W. T. Kirkman, Merced, Merced County: In this region irrigated fruit is superior to unirrigated in all respects.

Dr. W. N. Sherman, Fresno, Fresno County: Irrigated fruit is superior in size, quality, and flavor. Irrigated trees come into bearing in one half the time of other trees.



George C. Roeding, Fresno: Irrigated fruits average much larger and as a rule are much brighter in appearance. The flavor of fruits adapted to this section is very good and all are irrigated unless water is available by underflow.

Thomas Jacob, Visalia, Tulare County: Irrigated fruit is usually much larger and finer looking than fruit grown without water, but there is some question as to flavor.

J. V. Webster, Creston, San Luis Obispo County: Fruits properly irrigated are almost invariably larger and finer in appearance, but usually not so fine in aroma and color.

James A. Girard, Cayucos, San Luis Obispo County: Irrigated fruit is larger and better in general appearance, but the flavor and aroma are not improved. I am inclined to believe that on good soils fruit does as well here without irrigation as with it.

Elwood Cooper, Santa Barbara: Where it is possible to grow fruit without irrigation the quality is better; they are more firm and better in every way.

O. N. Cadwell, Carpinteria, Santa Barbara County: Our English walnuts need more water than we can get to finish up their growth and ripen, as the moisture leaves the ground fast from the last of July to September 15, when they seem to call for more. Most of our apples, pears, and peaches are poor without irrigation.

E. S. Thacher, Nordhoff, Ventura County: In high, well-drained situations, such as that of this ranch, all kinds of fruits that will grow here may be irrigated to their great advantage as to size and beauty and with no loss of flavor and aroma. Some restraint should doubtless be used when fruit is filling out, but to keep a tree in lively, thrifty growth by a continuous supply of moisture in a well-cultivated soil can only improve the quality of the fruit as well as the quantity.

H. J. Dennison, Nordhoff: Irrigation will give fruit one-third larger and more juicy.

Robert Dunn, Fillmore, Ventura County: Irrigated fruit is better in size, quality, and general appearance.

F. F. Stetson & Co., Los Angeles: Irrigated fruit is better in size and general appearance.

H. E. Chesebro, Covina, Los Angeles County: Irrigated fruit is larger, better in flavor and color.

H. D. Briggs, Azusa, Los Angeles County: Irrigated fruit is far superior, provided the water is not applied too near the ripening. With us water should not be used closer than three weeks of ripening.

Henry D. Engelhardt, Glendora, Los Angeles County: Water must be used with the best possible judgment, and when thus irrigated a tree or vine, if given proper cultivation between irrigation, will produce fruit which for size, flavor, aroma, and general appearance will doubly surpass that from a nonirrigated tree or vine.

J. A. Graves, Alhambra, Los Angeles County: For my own use I would prefer deciduous fruits grown on proper land without irrigation, but as a commercial proposition I should prefer to grow these same fruits with irrigation.

William Chappelow, Monrovia, Los Angeles County: Irrigated fruit is by far the best in every way.

W. W. Bliss, Duarte, Los Angeles County: Irrigated apricots, plums, and peaches are larger and more juicy; the pits of the peaches are more apt to split. These same fruits unirrigated are firmer, finer flavored, and contain more sugar.

L. L. Bequette, Whittier, Los Angeles County: The flavor of nonirrigated fruit is better, as it is not so watery.

J. Edson Smith, Santa Ana: I have been growing deciduous fruits for twenty years. As a general proposition, such fruits grown in southern California, with proper irrigation, are better in size, flavor, aroma, and general appearance, both of fresh fruit and dried or canned, than fruit grown without irrigation.

C. P. Taft, Orange, Orange County: Irrigated fruits are, in my opinion, superior to nonirrigated, climate and soil being the same, except when raised on naturally moist soil where irrigation is unnecessary.

A. S. Bradford, Fullerton, Orange County: My experience has been entirely in favor of irrigated fruits. I have neighbors who are trying to grow deciduous fruits with no irrigation, and hardly ever have any fruit. They wonder how I always have fruit in abundance and so fine. The secret is in the use of water. Irrigated fruits are very much finer, larger, and handsomer, and the flavor is excellent—none better.

J. B. Neff, Anaheim, Orange County: Irrigated fruits are usually much larger and finer in appearance.

C. J. Merryfield, Colton, San Bernardino County: Irrigated fruits are larger and of finer appearance, and as good in flavor as can be had.

W. S. Corwin, Highland, San Bernardino County: If properly irrigated and thinned, the irrigated fruit is larger, better in flavor, and in general appearance.

I. Ford, Redlands, San Bernardino County: Nonirrigated apples have high color, but in a dry year particularly are very much smaller and of poorer quality.

W. E. Atwater, Riverside, Riverside County: Fruit from irrigated trees is larger and more juicy, but when overirrigated the fruit lacks flavor.

Edward L. Koethen, Riverside: Our fruit is all irrigated, and apricots from non-irrigated trees are small as compared with ours. Olive trees will not bear here unless irrigated. Orange trees would die.

James M. Hyne, San Marcos, San Diego County: Irrigated fruit with me is larger and more fully developed, with flavor fully as good and in fact more luscious.

H. Culbertson, El Cajon, San Diego County: In our soil all the good qualities of fruits are improved by proper irrigation. I mean by proper irrigation the amount and frequency necessary to keep the tree in a thrifty condition so that at no time does it show lack of water. The soil may be oversupplied with water, when both flavor and aroma may be seriously affected. On our dry soils, without water, peaches will have a bitter flavor about the pit that is never found with irrigated. Apples without irrigation are small, thick-skinned, tough, and altogether undesirable, while if well supplied with moisture, say 4 inches per acre per month, will give good-sized, thin-skinned, tender and juicy, good-flavored fruit. With oranges the more regular and proper the supply of water the better the quality; very little water will not produce sweet fruit. Improper irrigation of oranges is doing much against the reputation of California oranges.

Chester Gunn, Julian, San Diego County: Irrigated fruits are larger and of as good flavor if properly irrigated, but when heavily irrigated, just at ripening, they are apt to be hurt.

C. J. Johnston, San Diego, San Diego County: Properly irrigated fruit is always superior. Size, flavor, aroma, and general appearance are almost under control of the grower who has irrigation water.

The foregoing testimony certainly establishes beyond question the quality and commercial standing of irrigated fruit through more than a thousand miles of distance along the Pacific coast. In this distance the conditions range from fairly wintry to strictly semitropical and from fully arid to quite humid, judged by the annual rainfalls in the different localities. In all these wide ranges there is the evidence of extended experience that irrigation improves fruits in all respects, provided water is supplied at times and in amounts which trees under the different circumstances require for the best discharge of their fruit-bearing function. Obviously there are conditions under which irriga-

tion is unnecessary, and there is irrigation practice which may tend toward the development of some desirable characters and the loss or reduction of others, but these facts do not militate at all against the wise use of water. The cases in which preference is expressed for nonirrigated fruits are manifestly those in which the natural moisture, conserved by thorough surface cultivation, is adequate. When this is the case, an excess of moisture by irrigation is liable to work injury by enlargement at the expense of quality, and growers are quick to detect this, but the other end of the scale, where quality is lost because the moisture is inadequate to the development of fair size, is more apt to be overlooked. The bent of the tree seems to be toward the attainment of size in its fruit. If it is sharply arrested in this by drought the fruit is tough, acrid, and scant of perfume. If the moisture is excessive, so that the tree has free course to indulge its bent for size, it fails to develop quality.

#### **IRRIGATED FRUIT IN LONG-DISTANCE SHIPMENT.**

The next point of inquiry was as to the suitability of properly irrigated fruit for shipment long distances, as is required by the present state of the world's fruit trade. During the last quarter of a century fresh fruits from deciduous trees have been carried longer distances in the world's commerce than ever before and in quantities altogether beyond anticipation indulged in at the beginning. It is also true that the fruits of this class which have successfully traversed longest distances are those grown by irrigation. The employment of irrigation is, of course, not the cause of this exceptional durability during transportation. The absence of rain and the consequent atmospheric aridity during the development of the fruit are the chief causes of the peculiarly durable tissue of the fruits and are the causes also of the resort to irrigation, which enables the tree to so thrive upon adequate soil moisture that it is able to meet both the thirst of the air and the requirement of the fruit. Fruit grown in a dry summer air is of the most lasting character. This was demonstrated by experience in parts of California where the winter's rain, conserved by constant summer cultivation, was adequate to the needs of the trees and vines. At first it was a question whether the same effect could be secured by irrigation during the dry season, and the impression that it could not prevailed quite generally. Later experience shows that this impression was wrong, and there can perhaps be no more sweeping demonstration of this than the fact that by far the greater part of the Pacific coast fruits successfully marketed on the other side of the continent and even beyond the Atlantic Ocean is grown by irrigation as a supplement to winter's rainfall. Still this fact is not wholly appreciated, and among growers unacquainted with irrigation practice there is still too wide a belief that it is the artificial use of water which makes fruit

soft and perishable. That this is not the case, when the water is wisely used, is supported by the following declarations of experience and observation, although dissenting opinions are also included:

## IDAHO.

W. G. Whitney, Payette: I have had the best of success in shipping irrigated fruit.

A. McPherson, Boise: My experience in shipping irrigated fruits has been very satisfactory.

L. A. Porter, Porters: Unirrigated apples are usually better keepers, as, not being fully matured, they wilt. With Bartlett pears the rule is reversed and the irrigated pear will hold up much better. All irrigated fruits are the best sellers, on account of size and general good qualities. I ship east some 200 cars annually from both irrigated and unirrigated sections.

## WASHINGTON.

E. H. Libby, Clarkston: Well grown, well picked, and well packed irrigated fruits ship safely and satisfactorily.

F. E. Thompson, North Yakima: I have had ten years' experience in fruit shipping, and have shipped irrigated fruit as far as New York City without complaints.

J. H. James, Waitsburg: I have had good success in shipping irrigated fruit.

## OREGON.

S. A. Miller, Milton: Irrigated fruit is always in demand, as it is larger and of higher color than the unirrigated.

R. H. Weber, The Dalles: Nonirrigated fruit being firmer will stand shipping better.

Seufert Brothers, The Dalles: Our irrigated fruit has shipped successfully, and we raise three to four times as much per acre.

J. R. Casey, Ashland: Shippers prefer irrigated fruits.

## CALIFORNIA.

George A. Lamiman, Anderson, Shasta County: I have shipped irrigated fruits for five years with an increasing demand for them. I have not shipped nonirrigated fruits, as they are too small.

W. E. Hazen, Manton, Tehama County: I have no trouble in shipping nor in selling irrigated fruits.

O. E. Graves, Redbluff, Tehama County: I have sold irrigated prunes to shippers, usually at good prices.

Fred Scharr, Redbluff: When a tree gets too much water the fruit will be softer and will not ship so well. The care is to irrigate deeper and not so often.

George H. Flournoy, Corning, Tehama County: Irrigated fruits, and in fact all irrigated products, carry as well as nonirrigated.

L. F. Moulton, Colusa, Colusa County: Reasonably irrigated fruits are so much larger and finer in appearance, and as the flavor is not deteriorated and the shipping qualities not impaired, it follows that such fruit is much sought for by shippers.

F. B. McKeivitt, Vacaville, Solano County: Irrigated fruit grown on uplands and where there is considerable iron in the soil ships perfectly. On heavier land it does not show the same shipping quality.

Foster Brothers, Dixon, Solano County: Peaches, prunes, and such fruits stand shipping well when irrigated, but pears do not.

E. A. Gammon, Courtland, Sacramento County: My experience in shipping irrigated fruit has been good; there is no hesitation on the part of shippers to buy irrigated fruits.

W. W. Hinsey, Fair Oaks, Sacramento County: Being more juicy, the irrigated fruits will perhaps not carry so well, but they will sell better, and we grow fruit to sell, not to keep.

Charles W. Landis, Folsom City, Sacramento County: Buyers seldom distinguish between irrigated and nonirrigated fruit, but what amounts to the same thing, they set standards of size, etc., which are more surely attained by irrigation. With the exception of the mildewing of grapes, I have never heard any complaint that irrigated fruits did not ship as well as nonirrigated. When fruit is sold on the trees a clause is inserted in the contract as to irrigation.

T. J. Wagoner, Rough and Ready, Nevada County: Irrigated fruits are not good in shipping if they are allowed to become too big and juicy.

T. J. Fitch, Loomis, Placer County: The shipping quality of properly irrigated fruits seems to be demonstrated by the fact that such fruits constitute a considerable part of our eastern shipments, and have for the last twenty years or more. In 1902 almost one-third of the fresh fruit sent east was shipped from Placer County, where irrigation is *sine qua non*. It opens out well if properly packed and cared for in transit.

P. W. Butler, Penryn, Placer County: There is but little nonirrigated fruit grown in this section, and this is generally rejected by shippers because of its inferior size.

W. R. Fountain, Newcastle, Placer County: In our home market we have shippers and buyers both soliciting irrigated fruit, and it is easy either to consign or to sell.

W. Sharwood, Soulsbyville, Tuolumne County: The apples from our irrigated orchards are said to bring the highest prices in the San Francisco market. No one is foolish enough to try to grow fruit in this district without irrigation.

J. M. Harris, Miami, Mariposa County: I have had good success in selling irrigated fruits.

John Rock, Niles, Alameda County: Irrigated fruit will carry well if irrigation is done in the winter or while the fruit is small.

Edw. M. Ehrhorn, Mountainview, Santa Clara County: I have had no difficulty in shipping irrigated fruits.

A. Block, Santa Clara, Santa Clara County: My experience favors irrigated fruit for shipping, provided it is not irrigated too close to ripening.

S. P. Sanders, Cupertino, Santa Clara County: I only irrigate in winter from a torrential stream; such irrigation is held not to affect the carrying quality of shipping fruits.

H. Hoops, Wrights, Santa Clara County: I have generally improved the quality of my fruit by irrigation, and therefore get better prices from fruit shippers.

J. V. Webster, Creston, San Luis Obispo County: My experience is that irrigated fruits do not ship so well as nonirrigated, decaying and fading in color much more rapidly.

Dr. W. N. Sherman, Fresno, Fresno County: For eighteen years we have obtained the highest prices on table grapes of any shipped from this State. In 1902 our table grapes netted us \$500 per acre. The fruit is grown with irrigation.

J. S. McCormick, Fresno: We irrigate everything. We sell to shippers to ship the fruit to the east, and hear no complaint about its not keeping.

George C. Roeding, Fresno: Shippers take irrigated fruits as readily as nonirrigated, and they carry fully as well.

Charles Downing, Armona, Kings County: My pears, grown on trees subirrigated by seepage from main canals, have always brought top prices in New York and Chicago. I have shipped peaches from trees similarly irrigated, but while some have brought good prices the result as a whole has not been satisfactory, the claim being made by consignees in many instances that the peaches from the district do not carry as well as those from the mountain districts.

Thomas Jacob, Visalia, Tulare County: Fruit grown on low land or where much water is used does not seem to carry as well as fruit grown on drier land.

C. A. Walter, Independence, Inyo County: Irrigated fruits are best for shipping. They are firmer, have better color, and look better when packed than fruit that has been scant of water.

N. J. Cooley, Bishop, Inyo County: I have market for more irrigated fruits than I can supply, and always at top prices.

William Chappelow, Monrovia, Los Angeles County: I think unirrigated fruit handles best.

W. W. Bliss, Duarte, Los Angeles County: Nonirrigated fruit ships better, as it is firmer than irrigated fruit.

Henry D. Engelhardt, Glendora, Los Angeles County: For shipping purposes, give me the irrigated fruit every time.

L. L. Bequette, Los Nietos (Whittier), Los Angeles County: Irrigated peaches and apricots will not stand shipping so well.

A. D. Bishop, Orange, Orange County: I have been shipping irrigated fruits and selling to shippers for more than twenty years with satisfactory results.

W. S. Corwin, Highland, San Bernardino County: A large, juicy apple, if picked at the proper time, will keep fully as well as nonirrigated fruit and will sell for a far higher price.

J. H. Reed, Riverside, Riverside County: We shipped no fresh fruits, but our irrigated fruit was much sought for by the local trade because of size and general appearance as well as quality.

Hemet Land Company, Hemet, Riverside County: We get the top price for all the irrigated fruits we raise.

T. J. Bryan, Lemongrove, San Diego County: I never shipped anything but irrigated fruit, which ships well if properly handled.

Chester Gunn, Julian, San Diego County: Where irrigated early the fruit is large and well colored, and preferred for shipping to that not irrigated.

C. J. Johnston, San Diego, San Diego County: I do not clip lemons immediately after irrigation or rains. The fruit is apt to be too sappy to hold up. I wait four or five days before clipping.

#### ARIZONA.

A. J. McClatchie, Phoenix: I shipped irrigated fruits regularly to the Pan-American Exposition at Buffalo, N. Y., with success.

The foregoing statements establish beyond question the availability of irrigated fruits for shipping and afford warning against the excessive use of water also, for it is clear that those of opposing view speak from experience with an amount of soil moisture which promoted overgrowth and softness of tissue. Some fruits are more liable to this evil effect than others on account of their own characteristic pulp formation. It is also true that perishability in the pulp is due to excessive moisture supply, whether it be from natural underflow or from irrigation, and, as might be expected, the greatest dangers in irrigation are likely to be encountered on low, rich, and retentive soils and the least danger in soils naturally drier and open to a free movement of water. This diversity in soil and situation explains some of the contradiction in the testimony, while other indications of the destruction of shipping quality are due to unguarded use of water.

### SUITABILITY OF IRRIGATED FRUITS FOR CANNING.

The next inquiry as to the value of properly irrigated fruits related to their suitability for canning. Upon this point there has been less controversy, and yet claims of superior richness and firmness in unirrigated fruits always carry a reference to thinness of juice and mushiness in processing which have been freely attributed to irrigation. When, however, it is shown that irrigation can be used to the general improvement of the fruit trees which are scant of moisture during the filling and ripening period of the product, the improvement includes the character which canners especially esteem and are willing to pay extra prices for. That this is true is shown by the following declarations which refer to irrigated fruit, particularly from the canner's point of view:

#### IDAHO.

A. McPherson, Boise: I have canned my own irrigated fruit and have sold it to canners—both very satisfactorily.

#### WASHINGTON.

J. H. James, Waitsburg: I have found irrigated fruit a little too juicy for canning.

F. E. Thompson, North Yakima: I have only canned irrigated fruit for our own use. We consider it fine.

#### OREGON.

Seufert Brothers, The Dalles: We can our irrigated fruit and sell it well. We pay 25 per cent more for irrigated fruit and find it cheaper for our canning.

#### CALIFORNIA.

Owen Dailey, Whitmore, Shasta County: I prefer irrigated fruit for canning.

George A. Lamiman, Anderson, Shasta County: Canners pay the highest prices for irrigated fruit, especially pears.

W. E. Hazen, Manton, Tehama County: Irrigated fruits can well and are profitably sold to canners.

J. L. Barham, Manton, Tehama County: Our fruit brings the highest prices and it is all irrigated. I have shipped to the eastern markets right from the tree mostly.

George H. Flournoy, Corning, Tehama County: I have received top prices from canners for irrigated fruits and never heard any complaint. For home canning I prefer irrigated fruit.

G. M. Gray, Chico, Butte County: My experience in canning irrigated fruits and in selling them to canners has been very satisfactory.

Rio Bonito Orchard Company, Biggs, Butte County: Our experience in selling irrigated fruits to canners has been satisfactory.

L. F. Moulton, Colusa, Colusa County: Being much larger, smoother, and finer, the irrigated fruits command the highest and best market among the canners.

F. B. McKevitt, Vacaville, Solano County: As a general thing canners prefer irrigated fruits because of the larger size.

Foster Brothers, Dixon, Solano County: Irrigated peaches and apricots are superior for canning, but not pears.

E. A. Ganmon, Courtland, Sacramento County: My experience in canning irrigated fruit has been good. I have no trouble with it.

T. J. Wagoner, Rough and Ready, Nevada County: Canners will not have the unirrigated fruit if they know it. While the irrigated fruit sells quickly the other is dull.

P. W. Butler, Penryn, Placer County: None but irrigated fruits can be successfully grown in this section for canning.

W. R. Fountain, Newcastle, Placer County: Canners are after our irrigated clingstone peaches.

C. H. Bentley, San Francisco: The question of irrigation is of vital interest to everyone engaged in the handling of California fruits. From the canners' point of view there can be no question as to the benefit of intelligent irrigation in soils which require it. Peaches are, perhaps, our staple, and their quality is generally improved by irrigation except when they are grown in a soil that enjoys a natural subirrigation.

John Rock, Niles, Alameda County: Canners never object to irrigated fruit if it is large and firm. Large sizes bring better prices.

Edward M. Ehrborn, Mountainview, Santa Clara County: I have had no difficulty in shipping irrigated fruits to canners.

A. Block, Santa Clara, Santa Clara County: I have no trouble selling irrigated fruits to canners; on the contrary, they like it.

S. P. Sanders, Cupertino, Santa Clara County: Canners' agents inquire on buying if apricots have been irrigated, and prefer those that have not been irrigated late.

J. H. Flickinger Co., San Jose, Santa Clara County: Irrigated fruit is good for canning.

F. M. Righter, Campbell, Santa Clara County: We think irrigated fruit is best for canning and canners prefer it, though its superior size may have most to do with their preference.

Dr. W. N. Sherman, Fresno, Fresno County: Where fruit, peaches in particular, is thinned and watered at the proper time it is much larger and greatly superior in every respect for canning purposes. We have canned from 4,000 to 7,000 cans a year of such fruit with success.

J. S. McCormick, Fresno: We sell irrigated fruit to local canners and to the canners of San Francisco at satisfactory prices.

George C. Roeding, Fresno: The flavor of canned fruits from irrigated sections is excellent.

Frank Femmons, Ahwahnee, Madera County: Irrigated fruit canned for home use has given entire satisfaction.

J. M. Harris, Miami, Mariposa County: I have had good success in canning irrigated fruit. I have now a jar of irrigated peaches that I put up in 1877. Irrigated fruit sold for canning has always brought the very highest price.

Thomas Jacob, Visalia, Tulare County: We think either very moist land or irrigation necessary to make good canning fruit.

W. S. Shelly, Hollister, San Benito County: Winter irrigation is no detriment to fruit for canning.

J. V. Webster, Creston, San Luis Obispo County: Manifestly size and general appearance are eminently essential in fruits for canning, and irrigation, properly pursued, tends toward those characteristics.

Robert Dunn, Fillmore, Ventura County: I prefer irrigated fruits for canning, and my experience is that canners take the best fruits, which can usually only be secured from irrigated trees.

F. F. Stetson & Co., Los Angeles: We use nonirrigated fruits almost wholly, but firmly believe that the fruit would be of better quality if the trees were irrigated moderately—say, twice during the season's growth. We believe such fruit would be of better size, flavor, texture (being firmer or less mealy), would cook better and look better after canning. Irrigated peaches have less red around the pit.



Henry D. Engelhardt, Glendora, Los Angeles County: Properly irrigated fruit will can best, but overirrigated fruit will be watery and will spoil easily.

H. D. Briggs, Azusa, Los Angeles County: For nineteen years I have canned, largely for home use, and have sold large amounts to canners, and always received the top price for well-grown, irrigated fruit.

W. W. Bliss, Duarte, Los Angeles County: I have sold but few peaches to canners. For our own use we like nonirrigated fruits better.

J. B. Neff, Anaheim, Orange County: Canners buy irrigated fruits in preference because of superior size. The fruit will be equally solid as the nonirrigated if not watered within one month of picking.

C. P. Taft, Orange, Orange County: Fruit irrigated before ripening is better for drying but not for shipping or canning, but fruit on any soil which lacks sufficient moisture will be better if irrigated whether dried or sold to canners.

A. S. Bradford, Fullerton, Orange County: We never have any trouble canning irrigated fruit, and canners prefer irrigated fruits because they are larger and finer. Such fruits command about \$10 per ton more on account of size, etc.

C. J. Merryfield, Colton, San Bernardino County: Canned irrigated fruit has a fine appearance and superior flavor.

W. S. Corwin, Highland, San Bernardino County: I have had first-class success in canning irrigated fruits and in selling to canners.

James Boyd, Riverside: No objection is ever made to irrigated fruits by canners; on the contrary irrigation gives more desirable fruit for canning.

Joseph Wallace, San Jacinto, Riverside County: Fruit moderately irrigated is much better for canning purposes.

H. Culbertson, El Cajon, San Diego County: Well irrigated fruit is practically the only fruit that canners will buy in this section.

This declaration of the suitability of irrigated fruit for canning is of great commercial significance, and it should be considered in connection with the present output of the canning industry in California, as compiled by the California Fruit Grower and published in its issue of April 9, 1904:

*California fruit and vegetable pack by varieties.*

Variety.	Cases. <sup>a</sup>		Variety.	Cases. <sup>a</sup>	
	1902.	1903.		1902.	1903.
Apples.....	6,683	5,023	Strawberries.....	6,205	15,320
Apricots.....	236,071	648,716	Total table fruits..	1,925,326	2,415,941
Blackberries.....	16,661	35,556	Pie fruit, 2½ pounds.....	77,889	49,582
Cherries, Royal Ann.....	119,297	103,894	Pie fruit, gallons.....	203,596	231,496
Cherries, black.....	26,566	30,506	Jams and jellies.....	45,979	36,465
Cherries, white.....	43,119	63,392	Total fruits.....	2,252,790	2,733,504
Currants.....	219	95	Tomatoes, 2½ and 3 pounds	750,810	835,394
Figs.....	1,388	1,000	Tomatoes, gallons.....	76,242	122,901
Gooseberries.....	536	.....	Peas.....	57,710	70,487
Grapes.....	31,052	52,621	Asparagus.....	227,126	256,220
Loganberries.....	194	4,307	Beans and other vegeta-	39,380	58,572
Nectarines.....	755	341	bles.....		
Pears.....	302,962	423,831	Total fruits and	3,404,058	4,077,078
Peaches.....	353,036	339,375	vegetables.....		
Peaches, cling.....	624,528	550,777			
Plums.....	150,447	125,567			
Quinces.....	2,402	115			
Raspberries.....	2,975	6,505			

<sup>a</sup>2 dozen 2½ pound cans.

Upon the basis of 5 cents per pound, selling price for canned fruits, and 2½ cents per pound for canned vegetables, the valuation of this

product in 1903 is over \$10,500,000 and the products still meet a growing demand. The canning quality of irrigated fruits thus becomes of the widest importance in the development of those parts of the arid region which favor the growth of fruits and vegetables desirable to canners.

### SUITABILITY OF IRRIGATED FRUITS FOR DRYING.

The next inquiry related to the suitability of properly irrigated fruits for drying. This is a quality which has had to meet a strong negative from the first and many growers are still disposed to deny it. This is not remarkable, for does it not seem reasonable that fruit which has to be brought into preservable form by the expulsion of a large percentage of its moisture by heat would be made better for that process by growing it in a way which would naturally reduce the amount of that moisture? In fact, so strongly did this consideration appeal to many growers a few years ago that it seemed to them silly, as the common saying was, "to force a tree to pump its fruit full of water which has to be driven off again in the preparation of the product." Several propositions which are fundamental in successful fruit drying were not then recognized at their full value. They are better understood now because the chemists have made many comparative analyses of dried fruit, because the dealers have learned what consumers will pay most for, and because growers have secured many hints of practical value from their own experience. The breadth of this experience can be readily understood when it is remembered that in California alone the annual product of dried fruits of all kinds is nearly 340,000,000 pounds, and not less than half of this amount is made from fruit grown with irrigation, and this half has a vastly higher market value than the other half. A few of these propositions which have been shown to be fundamental in successful fruit drying may be briefly stated, as follows:

(1) The best dried fruit is secured from the fruit which is best before drying.

(2) Good size is as profitable in dried fruit as in fresh or canned fruits.

(3) Fruit which is deficient in flavor and richness does not improve in drying and acrid flavors which are apt to be developed in fruit which is not able to mature properly are intensified in drying.

(4) Though the best drying fruits are those which naturally possess a certain firmness of texture and density of juice, it is not possible to imitate these natural conditions nor to advance them by denying the tree the amount of water which is necessary to the vigor of the tree and the full development of the fruit. For instance, the Muir peach has naturally rather dry flesh and the popular cling peaches are of very firm flesh, but these natural endowments of the varieties can not

be successfully produced in other varieties nor enhanced in the varieties themselves by denying the trees the water necessary to produce satisfactory size of fruit, for it is clearly shown by all lines of investigation that adequate size, in each variety according to its own natural standard, helps in the development of other qualities of the variety in their fullness.

(5) While all these things are true it is also true that water in excess of the amount required by the tree to attain its highest quality of product is apt to force the tree beyond its best work and it matters not whether the water reaches the roots by irrigation or by natural movements of water through the soil. Of course in a semiarid country there is greater danger and greater actual occurrence of excess by irrigation than by natural movements and consequently blame attached to it in the popular mind.

These considerations hold in the growth of fruit for all purposes, but they are advanced in this place because in the growth of fruit for drying the sharpest issues have arisen, the greatest inconsistencies have been alleged against irrigation, and this is the place for the vindication of the practice of irrigation against wrong conceptions of its effects. This is the last ditch of the nonirrigators, and a deep stream of water is now flowing through it, as the following reports clearly demonstrate:

## IDAHO.

L. A. Porter, Porters: I have found that irrigated prunes make the better cured product, as they have more sugar in the juice and dry plumper. I can pay more for them.

A. McPherson, Boise: I have had good results in drying irrigated fruits.

W. G. Whitney, Payette: I have had splendid success in drying irrigated fruits.

## WASHINGTON.

F. E. Thompson, North Yakima: I have only dried irrigated prunes. One hundred pounds French yield 41 pounds dried; 100 pounds Italian yield 32 pounds dried.

J. H. James, Waitsburg: I have had good results in drying irrigated fruits.

## OREGON.

Seufert Brothers, The Dalles: We knew that driers pay the largest prices for the largest fruit. In a dry country the fruit gets sun enough to offset any greater amount of water supplied by irrigation.

## CALIFORNIA.

Owen Daily, Whitmore, Shasta County: I consider irrigated fruit best for all purposes.

George A. Lamiman, Anderson, Shasta County: As irrigated fruit is larger and better flavored, it commands a higher price after drying.

O. E. Graves, Redbluff, Tehama County: Irrigated prunes are as easily dried as those not irrigated.

Fred Scharr, Redbluff: Irrigated fruit will shrink more in drying.

J. L. Barham, Manton, Tehama County: We have had first-class results in drying irrigated fruits.

Mrs. Emma E. Yager, Manton: According to my experience irrigated fruits dry well.

W. E. Hazen, Manton: Irrigated fruit makes better dried fruit than nonirrigated; it has a better flavor.

George H. Flournoy, Corning, Tehama County: If properly irrigated, fruits of all kinds make a better dried product than nonirrigated fruits.

G. M. Gray, Chico, Butte County: It takes a few more pounds of irrigated fruit to make a certain weight of dried fruit, as a rule.

Rio Bonito Orchard Company, Biggs, Butte County: Our experience in drying irrigated fruit has been satisfactory.

L. F. Moulton, Colusa: Reasonably irrigated fruits dry well and sell for the highest prices to driers.

G. W. Thissell, Winters, Yolo County: It requires more pounds of irrigated fruit to make a pound of dried fruit than it does of nonirrigated fruit, but the heavier yield and the larger size under irrigation, also the advantage in handling, drying, and selling large fruits more than compensate for the greater shrinkage in drying. The money is in the irrigated orchard.

F. S. McKevitt, Vacaville, Solano County: If properly irrigated the fruit will dry as well, and the yield from the same weight of fresh fruit will be as large as with the unirrigated.

Foster Brothers, Dixon, Solano County: The drying of irrigated fruits of all kinds is satisfactory.

John Rock, Niles, Alameda County: Fruit grown with winter or early spring irrigation will dry as well as unirrigated and is more profitable, as it is of better size. It will have more sugar than fruit grown on dry land.

Edward M. Ehrhorn, Mountainview, Santa Clara County: There is a little more loss in drying irrigated fruit, but I believe this is offset by the larger size of the fruit secured by irrigation.

S. P. Sanders, Cupertino, Santa Clara County: Fruits irrigated late in the spring and in early summer shrink more and are off in flavor. Driers buying fruit green seek and pay more for nonirrigated, but growers hardly understand the reason for the discrimination.

J. H. Flickinger Company, San Jose, Santa Clara County: In drying, the shrinkage is greater with irrigated fruit.

F. M. Richter, Campbell, Santa Clara County: If fruit is heavily irrigated late in the season it will show greater shrinkage in weight in drying, but it will not otherwise be inferior. The commercial driers look upon it in this light and prefer irrigated fruit, because the product is larger and hence of better grade.

W. S. Shelly, Hollister, San Benito County: Winter irrigation causes no greater shrinkage.

J. V. Webster, Creston, San Luis Obispo County: As irrigated fruit is larger, and as the larger dried fruits have the higher commercial value, irrigation is often an important agency toward profitability, but my observation is that the nonirrigated fruit excels in everything but size.

Charles W. Landis, Folsom City, Sacramento County: The better the green fruit the better the dried fruit.

W. T. Kirkman, Merced: Muir peaches well irrigated will dry about one from five and make first-class dried fruit, selling for the highest quoted prices. We have had very satisfactory success in drying irrigated fruits.

George C. Roeding, Fresno: Irrigated fruits dry as well as nonirrigated and are much brighter in appearance.

Dr. W. N. Sherman, Fresno: We dry about 150 tons annually of raisins, and have done so for about ten years. We dry about 25 tons of peaches. All these are grown by irrigation.

John C. Nourse, Fresno: The percentage of shrinkage or loss of weight in drying fruit, either irrigated or nonirrigated, is about the same, except where the water has been applied immediately preceding the ripening of the fruit, when the shrinkage in the irrigated fruit is greater. Our dried fruit from irrigated apricots, pears, peaches, nectarines, and raisin grapes compare favorably with the same fruits in any other part of the State.

J. S. McCormick, Fresno: We dry irrigated fruit every year, and it commands as good prices as nonirrigated fruit in other parts of the State.

Charles Downing, Armona, Kings County: Orchards in this district are chiefly grown by seepage irrigation from main ditches. Almost all the peaches and apricots are dried, yielding usually a little more than a ton of dried fruit to the acre. Raisins also go about a ton to the acre for the first crop, second-crop grapes going mostly to the wineries. A piece of 20 acres, or allowing for avenues, etc., about 17 acres actually, of Muscat vines, planted 10 by 10 feet, produced, in 1901, 96.4 tons of grapes of 22 per cent sugar test. In 1902 this same piece gave 168.4 tons of about the same sugar test. The vines were 13 years old in 1901. One edge of this vineyard is one-eighth of a mile from the nearest ditch.

Thomas Jacob, Visalia, Tulare County: Nonirrigated fruit dries heavier and retains its color better after bleaching than fruit grown on wet land or with much irrigation.

J. M. Harris, Miami, Mariposa County: I have always dried irrigated fruits with the best success.

C. A. Walter, Independence, Inyo County: Irrigated fruit, being large and rich in flavor, is the best fruit for drying.

Robert Dunn, Fillmore, Ventura County: I prefer irrigated fruit for drying, as it is as a rule larger.

Henry D. Engelhardt, Glendora, Los Angeles County: Deciduous fruit grown with about two light irrigations during the dry season in southern California will produce the best results in drying qualities.

J. B. Neff, Anaheim, Orange County: Driers prefer irrigated fruit, if not irrigated within a month of ripening.

A. S. Bradford, Placentia, Orange County: The fruit driers make no distinction between irrigated and nonirrigated fruits, and the largest fruit commands the best price.

A. D. Bishop, Orange, Orange County: My experience in drying irrigated fruits has been entirely satisfactory.

H. D. Briggs, Azusa, Los Angeles County: I have dried fruit every year since 1890, more or less, and always with fair results. I always prefer irrigated fruit, if water has not been used within three weeks of ripening.

L. L. Bequette, Whittier, Los Angeles County: Irrigated fruits do not dry so well.

W. S. Corwin, Highland, San Bernardino County: Irrigated fruit dries well.

Joseph Wallace, San Jacinto, Riverside County: Nonirrigated fruit is much better for drying, provided, of course, that it will attain proper size without irrigation.

Hemet Land Company, Hemet, Riverside County: We have dried irrigated apricots and peaches for five years and always get paying prices for them.

Edward L. Koethen, Riverside: Irrigated apricots make an excellent dried product.

J. H. Reed, Riverside: I kept careful account during two or three years of our dried irrigated fruits as compared with the same kinds of fruit unirrigated which we dried for neighbors under precisely the same conditions. I was surprised at the increased product of cured fruit from the irrigated lots. As to quality, the increased price received for the fruit settled that.

H. Culbertson, El Cajon, San Diego County: Our experience is that irrigated fruit is the only fruit that will pay expenses. By actual test I have found the actual cost of preparing peaches for drying to be two or three times more for small fruit than for large fruit well developed under irrigation. Of course, thinning (or spacing the fruits on the twigs) is one of the most important factors.

Very clear conclusions can be secured from a careful study of the foregoing declarations of experience. It is desirable to consider them as a whole and not as isolated statements. For instance, Mr. Thissell's and Mr. Ehrhorn's statements complete the showing of the greater shrinkage in drying, as shown by Mr. Gray, the Flickinger Company, and others, and Mr. Jacobs shows that shrinkage is experienced in fruit grown on land naturally wet as well as on that excessively irrigated, while Mr. Wallace shows when nonirrigated fruit is superior and explains the preference which Mr. Bequette has expressed in all the answers which he has made. He has land naturally moist enough for the fullest requirements of the trees and has no need of irrigation. Reading dissent then in the light of such interpretation there remains a clear and emphatic affirmation from the experience of many that irrigation is widely the surety of satisfactory size and quality and of profit in the growth of fruit for preservation by evaporation.

### IRRIGATED FRUITS AT POMOLOGICAL FAIRS.

The pomological fairs within the irrigated regions and the great expositions at home and abroad during the last quarter of a century have afforded an opportunity for contrasting displays of irrigated and nonirrigated fruits. Irrigated fruit is conceded to be rich in show features. Its size and beauty have always commanded admiration, and its superior attractiveness has been sufficiently demonstrated by the fact that in earlier expositions in California, and possibly elsewhere also, it was often set apart in a class by itself, so that the competition of nonirrigated fruit with it for the same awards might be avoided. A question was, however, addressed to growers as to their experience with irrigated and nonirrigated fruits at the fairs, in the hope that some instructive contrasts might be brought to light. The answers received do not, however, attain such ends, although they do constitute an interesting record of experience, and in some cases shed a unique light on the durability of irrigated fruits in long shipment and during the trying exposure on the show plates. There has perhaps been no clearer demonstration of these facts than the award at the Paris Exposition of 1900 to the apples grown with irrigation in Idaho. The same behavior of irrigated fruits has been manifested at all American expositions since the Centennial, at Philadelphia, in 1876, which was the first great opportunity for the irrigated fruits from California. The following declarations of individual experience along these lines are of interest:

#### IDAHO.

L. A. Porter, Porters: My irrigated fruit was given awards at the Columbian Exposition, at the Pan-American, and at the Spokane Fruit fairs for many years.

A. McPherson, Boise: My irrigated fruits have taken prizes at the Chicago, New Orleans, and Omaha expositions.

## WASHINGTON.

E. H. Libby, Clarkson: Irrigated fruits of this valley have won prizes at the Columbian Exposition, at Omaha, at Spokane Fruit Fair year after year, and sweepstakes regularly at the Lewiston State Fair.

F. E. Thompson, North Yakima: Our irrigated fruit has taken awards at Washington State Fair and at Spokane Fruit Fair.

## OREGON.

S. A. Miller, Milton: I was given awards at the Spokane Fruit fairs in 1895 and 1896 for the largest apple on exhibition.

Seufert Brothers, The Dalles: We took prizes for our irrigated cherries and Hungarian prunes in the Oregon exhibit at the Columbian Exposition.

J. R. Casey, Ashland: I have taken prizes with irrigated fruit at the southern Oregon district fairs.

## CALIFORNIA.

W. E. Hazen, Manton, Tehama County: My irrigated fruit has won prizes at the Redbluff district fairs.

J. L. Barham, Manton: Our irrigated apples have taken prizes at the State fairs whenever exhibited.

George H. Flournoy, Corning, Tehama County: I have always received a majority of the premiums at county fairs in my county and received gold medals at the Mid-winter Fair in San Francisco.

L. F. Moulton, Colusa: My irrigated prunes won the highest awards at the Mid-winter Fair of 1894.

John Rock, Niles, Alameda County: My irrigated fruit took a gold medal at the California State Fair in 1896, also a Wilder medal for olives at the meeting of the American Pomological Society in 1895.

A. Block, Santa Clara: The American Pomological Society at its Cedar Rapids meeting gave me a Wilder medal for irrigated pears.

T. J. Wagoner, Rough and Ready, Nevada County: Placer and Nevada counties have taken leading prizes at leading fairs and the fruit was all from irrigation.

P. W. Butler, Penryn, Placer County: Ten to fifteen years ago I exhibited irrigated fruit yearly at the State fairs in Sacramento, and on peaches have always taken prizes—sometimes more than any other exhibitor in the State.

W. N. Sherman, Fresno: We received a gold medal for irrigated fruits at the Paris Exposition; two gold medals and eighteen blue ribbons at the California State Fair of 1902 for irrigated fruits and other local awards.

George C. Roeding, Fresno: Our irrigated fruits won prizes at the State Fair in 1902 and at county fairs for a number of years.

C. A. Walter, Independence, Inyo County: I have taken prizes with irrigated fruits at the Inyo County fairs a number of times.

A. D. Bishop, Orange: I was awarded a medal at the Columbian Exposition in 1893 for irrigated fruits and have taken numerous premiums at our county fairs.

C. P. Taft, Orange: My irrigated loquats took a diploma at the Pan-American Exposition. I have won many prizes with irrigated fruits at the fairs in California.

D. Edson Smith, Santa Ana, Orange County: My irrigated deciduous fruits, both fresh and dried, have taken first prizes at several fairs of the Southern California Pomological Society in Los Angeles.

James Boyd, Riverside: I have had the best success and have taken premiums at the Los Angeles and other fairs, both for fresh and dried fruits, in competition with unirrigated fruit from other southern counties.

H. Culbertson, El Cajon, San Diego County: I have taken prizes for irrigated fruits at our county fairs and at the Columbian Exposition.

## ARIZONA.

A. J. McClatchie, Phoenix: Our irrigated fruits won prizes at the Pan-American Exposition.

**INJURIES ALLEGED AGAINST IRRIGATION.**

The last inquiry submitted to correspondents was intended to afford opportunity for alleging all objections to the use of water in fruit growing, so that full measure could be taken of this phase of the collective mind of fruit growers. Naturally, though many correspondents expressed themselves in answer to the question: "Do you know of fruits or fruit trees or vines being injured in any way by irrigation, and if so, in what respect?" there were but few distinctive objections and much repetition in the recital of them by different observers. For this reason the plan of citing individual declarations, which has been followed in the compilation under the previous headings, will be abandoned and, in the interest of brevity, only objections in some respect different from others will be entered upon the following rough classification of statements:

## INJURIES DUE TO THE GROWER HIMSELF.

Careless irrigation often injures trees and vines.

The things to know are when to irrigate and how much. Just enough at the right time insures the best possible results, but some growers seem to be unable to learn this.

Trees are not injured when intelligence enters into the use of water.

Fruit trees are often injured by too much irrigation—in fact, many are killed by it. It also spoils the fruit.

## INJURIES DUE TO THE WATER.

Too much water remaining too long around the stems of low-set orange trees causes root rot or gum disease.

Some kinds of fruit are especially injured by overirrigation.

Trees can be drowned by too much water or may die from too little of it.

Some grapevines have been killed—apparently by too much water.

Deciduous fruit trees are injured by too much water and by allowing it to run around the body of the tree.

Too much water on or near the surface will injure fruit trees. Some orchards where water is plentiful are being ruined by too much of it, even in the mountains where natural drainage is usually all that could be desired. The trees are sickly and the fruit of little value.

If too much water is used the fruit will drop and the trees show a sickly appearance in the middle of the spring. Moderate irrigation will not do this.

Orchards and vineyards are killed by overirrigation, because of the raising of the water level too near the surface.

In low places, especially where the ground water is too near the surface, irrigation has had bad effects. Fruits have not such good flavor, grapes are late, and sometimes trees are killed.

Orchards have been killed outright by constant irrigation by Chinamen growing vegetables among the trees.

One prune orchard of 150 acres, in Santa Clara County, Cal., has been abandoned and the trees dug out. For ten years they have been irrigated abundantly, at great



expense, and supplied with fertilizers also. Adjoining orchards not irrigated are still thrifty and bearing tolerably well. It has been claimed that the water washed the fertilizing substance out of the soil.

Summer irrigation promotes a root system near the surface and proper development of fruit on trees with such a system of feeders requires irrigation. In other words, an orchard once irrigated will suffer more from drought than one never irrigated.

#### INJURIES DUE TO LACK OF DRAINAGE.

Where water is allowed to stand or there is insufficient drainage the leaves turn yellow, and if the trees are not looked to they are apt to die.

Too much water with poor drainage will sour the soil and cause gum disease and yellow leaf.

Trees can be injured, especially on roots which do not like too much water and on soils where the subdrainage is defective.

Thousands of acres of trees and vines are seriously injured by seepage of water from ditches and the raising of water levels. Drainage of land to remove surplus water is one of the greatest needs in some localities.

There are 35-year-old apple trees at the Hicks ranch in San Bernardino County, Cal., that have a ditch of water running constantly within 5 feet of the trunks and yet are very thrifty and bear nearly every year apples of highest quality. They will not grow, however, in a swamp, but must have some drainage.

Fruit trees are injured by subirrigation without drainage for surplus water. Standing water is destructive to the roots.

There may be injuries by irrigation in the case of using excessive amounts of water a few days before picking. Walnuts are never injured by irrigation on land that has good underdrainage. The land might be leached out, perhaps, but there is no direct injury to the tree.

#### INJURIES DUE TO LACK OF CULTIVATION.

Trees are injured by too much irrigation and not sufficient cultivation.

Too much water continuously will check growth, turn foliage yellow, and stunt the tree. The land should be cultivated between irrigations until there is but little moisture at the surface, but not allowed to become dry enough to curl the leaves. This will make healthier trees and a better quality of fruit than overirrigated land, but the irrigation should be thorough and deep.

Too much or too frequent flooding around the tree with too little cultivation between irrigations may do injury. Too many people who have plenty of water use it too frequently, thinking to escape the trouble of cultivation.

Sometimes fruit trees are irrigated continuously and never cultivated so as to open the soil to sunshine and air. Such trees are not so stocky and strong.

Irrigation without cultivation—and that in the most thorough manner—is productive of injurious results, and where irrigation has not given satisfactory results it will be found that it was not followed by the proper cultivation.

#### INJURIES DUE TO TEMPERATURE DURING IRRIGATION.

Where hardpan is near the surface, care must be taken or the tree or vine is very likely to be injured if much water is applied in warm weather.

Carelessness in flooding trees in hot weather may injure them, but when judgment is used in irrigating, trees are not injured by water.

Both trees and vines may be "scalded" by allowing water to stand too long in hot weather.

Orchards have been injured by too much irrigation, causing the roots to scald.

In the daytime the ground and the water get hot, and to let the water strike the tree then will scald the bark. It takes very little of that to ruin a tree.

Sunshine reflected from water running below against the trunk causes sunburn.

There have been a good many orange trees ruined by flooding the trees, running a furrow, or digging to the root crown, thereby cooking it and finally ruining the tree.

Fruit trees are sometimes injured by receiving too much water during hot spells during the summer.

In Arizona fruit trees have been injured by scalding, even when a very small amount of water has been put on in hot weather.

In Idaho trees left to dry out in summer have been made to take a late growth by irrigation and have suffered by early freezing. It is also true that trees have been saved, by having irrigation late in the fall, from a heavy winter freeze where there was lack of moisture, while unirrigated trees in the same locality were killed by drying out by such severe freezing. Water to keep trees from destruction by "freezing dry" must be applied late and when the temperature becomes low enough to prevent new growth.

#### INJURIES TO FRUIT BY IRRIGATION TOO NEAR RIPENING.

Flavor and keeping quality of the fruit are hurt by heavy irrigation just as the fruit is ripening. The best time to irrigate is early in the growing season.

Water at some periods is said to retard the ripening of fruits.

Late and excessive irrigation is injurious both to fruits and their products.

If irrigation is applied within three weeks of ripening the fruit is apt to be watery and liable to decay.

In Nevada County, Cal., a large, late, blue grape (*Ramonia Transylvania*), with water running near the vine all summer, never ripened and hardly colored, keeping sour and green, while on the other vines of the same kind (but little irrigation or none at all) the grapes ripened nicely, being of a dark-blue color.

Winter irrigation is often superior to summer irrigation for deciduous fruits. Many injure their orchards and affect the fruit disadvantageously by late irrigation, especially after the fruit begins to mature.

Some peaches and apricots have overgrown and lost flavor from too much water. Apricots are very sensitive to water, and with reasonable rainfall, and well cultivated and thinned, will mature good fruit without irrigation, as they nearly all ripen in July. Early peaches will not stand much water.

Study of these alleged injuries due to irrigation clearly shows that they are attributable not to irrigation but to the errors in the use of water. Every other agricultural agency is not only subject to misuse, but is actually misused with resulting injury, hardship, and loss; but as irrigation is a newer art to Americans and its requirements not well understood, it is not strange that injury properly attributable to the actor is so frequently attributed to the instrument. It becomes clear, then, that there is no blame attaching to irrigation which might not also attach to rainfall or to natural overflow—in fact irrigation, being wholly under the control of the operator, should be held the more innocent. It is an old proverb that "no man can farm against the weather," but it is certainly a fact that a man can farm against injuries by irrigation as soon as he has the requisite intelligence and the energy to act upon it. There is, manifestly, no injury by irrigation which can not be avoided by the use of the right amount of water

at the right time and in the right way upon the soil naturally right for it, or corrected by the arts of tillage and drainage, and these corrective arts are neither new nor peculiar to irrigation practice; they are the old arts which have demonstrated their value through centuries of rainfall farming.

And yet, simple as the matter is upon last analysis, the steps of attaining it are really new and strange and are apt to fail of recognition and appreciation. In connection with his response to the questions of the present inquiry, Mr. J. H. Reed, of Riverside, Cal., gives these pertinent observations and conclusions:

There is one thing we must keep more prominently in mind; that is, that successful, practical irrigation is not so easy a thing to learn and practice as many suppose. The blundering unsuccess of untrained beginners does more to retard the progress of irrigation in new districts than all things else. I recently visited a semiarid section in Nebraska where a few years before a much-needed irrigation plant and plenty of cheap water had been secured. It had proved so unsatisfactory as to discourage not only those immediately interested but the whole region as to the practicability of successful irrigation. I found the condition easily explained by the utter carelessness of application and management of water, while with practical direction it might have been made of vast benefit locally and a useful object lesson for the whole region.

I fully understand that irrigation of deciduous fruits may be mismanaged or overdone, as with citrus fruits, but I can not understand at this late day how there can be any question as to the great value of irrigation intelligently applied to deciduous fruits, both as to quality and quantity of product.

The foregoing observations and conclusions explain why it is necessary to undertake such inquiries as form the basis of this report. Though the practice of irrigation will be continually improved by the results of scientific experimentation and exposition, the extension of the practice and the realization of the benefits thereof will be largely achieved by the wide publication of the teachings of experience.

# IRRIGATION CONDITIONS IN IMPERIAL VALLEY, CALIFORNIA.<sup>a</sup>

By J. E. ROADHOUSE, *Agent and Expert.*

## SALTON SINK.

Salton Sink is situated in the eastern part of San Diego County, Cal., hemmed in by scattered spurs of mountain ranges. On the north is the Chocolate Range, an extension of the San Bernardino Mountains; on the west and southwest are the San Jacintos and Cocopahs, interrupted by Signal Mountain at the north end of Laguna Salada (Salt Lake), a body of water which is replenished annually from the south by the Colorado overflow. In the northeast the Colorado is kept out by 30 or 40 miles of sand hills, often capped with mesquite trees, which diminish in size and number toward the international boundary, almost disappearing along the Alamo channel. There is a gentle slope of from 5 to 10 feet per mile to the northwest from Volcano lakes, and the elevation ranges from sea level at the boundary to 287 feet below sea level in the trough of the sink. The sand hills on the west have been aptly named Superstition Mountains because of their unstable character, the hills advancing by the sand falling over from the top in the direction the wind is blowing. Mud volcanoes in the vicinity of Volcano lakes (from which the lakes are named) and along the east rim of Salton Sink well up quantities of hot mud, which forms smooth, cone-shaped piles about their craters, or flows sluggishly down the slope. At about sea level and along the north and east sides of the valley an old sea beach is plainly visible, strewn with logs and periwinkle. In the north several fresh-water springs come out in this beach formation, and flowing wells are found along the line of the Southern Pacific Railroad.

It is probable that Salton Sink was once a part of the Gulf of California, into the north end of which Colorado River emptied its millions of tons of silt and suspended organic matter, both vegetable and animal. The continued process gradually elevated the river mouth, forming a delta, which finally built itself across the gulf to the Cocopah Mountains, making a large inland sea. The flow into this sea grew less as the silt barrier increased, and finally ceased, except

---

<sup>a</sup> This report is based on field observations made in Imperial Valley in the summer of 1903.

during the period of overflow, when a layer of mud would be spread over the gently sloping plain, decreasing in size of particles toward the north, and leaving sediment in fan-shaped layers. A boring for artesian water at Imperial has shown a succession of these layers to a depth of 598 feet, within which no water was found. The soil consists of two distinct classes, one a hard compact clay, wetting slowly and becoming plastic and adhesive, found along New River and formed by backwater; the other a silt or loam soil, found in a broad belt in Mexico and extending along and to the east of Salton channel. The latter soil is of the class formed by flowing waters, and ranges from fine silt to sand, with occasional clay. It is easily tillable, absorbs water readily, and melts down quickly with irrigation. Coarse and sandy in Mexico, it grows more clayey toward the sink.

To the eye most of the plain of the valley appears smooth and level, with occasional sagebrush and arrow weed. Where moisture is plentiful arrow weed (*Pluchea sericea*) grows abundantly, forming dense groves 6 to 10 feet high. Around the salt spring called Soda Spring, near the mouth of San Felipe Creek, a heavy growth of salt grass (*Distichlis spicata*) occurs, accompanied by mesquite (*Prosopis juliflora*). Cottonwoods (*Populus* spp.) and willows (*Salix* spp.) border Cameron and Blue lakes in the course of New River. The creosote bush (*Larrea tridentata*) is widely distributed. In the region of Salton Sink the saltwort (*Sueda* sp.) is abundant and suggests the presence of alkali.

Late in the fifties a bill was presented to Congress providing for national aid in the construction of a canal from the Gulf of California, in Mexico, to Salton Sink, leading the waters of the Gulf into the sink and making an inland sea with an area of over 500,000 acres. It was hoped thus to put an end to the hot winds which blow from the south over the San Jacinto Mountains into Riverside and West San Diego counties and burn up the crops. A sea 25 miles wide and 60 miles long would be substituted for a barren desert, and the Gulf breezes, instead of parting with their moisture, would be further charged by the rising vapor from the inland sea and carry this moisture to the west side of the San Jacintos. The civil war caused this project to be forgotten, but another way of moderating the climate, quite as effective and more profitable to the country if successful, yet entailing great risks, was later worked out, namely, the conversion of this desert into vast irrigated fields, and it is with this that this brief report deals.

Colorado River is about 60 miles from Salton Sink. For years engineers considered means for diverting this river into Imperial Valley in the sink, their plans being invariably rejected by capital as involving too great risk. In 1891 an unusually large precipitation on the Colorado watershed caused the period of high water to be long

extended, resulting in the flooding of thousands of acres in Mexico and in a large flow into Salton Sink, lasting from March until July. This flow was so great that the lower levels of the sink were covered and the flood found its way to Salton, in the northern end of the region. The luxuriant growth of vegetation that followed the subsidence of this flood demonstrated the great fertility of the soil of the valley.

### CLIMATE.

The situation and topography of Imperial Valley lead one to expect long, hot summers. The days are hot from May until September, and the glare of the sun on the light, fawn-colored earth is intense. During June and July a southerly breeze in the evening makes most of the nights comfortable. This will improve with the wide extension of vegetation. Most objectionable are the dust storms, common during this season. These winds are responsible for the migratory sand hills, which in some instances reach a height of 30 feet. With the extensive growth of trees and plants these conditions will improve.

The low humidity makes the sensible temperature less than the thermometer suggests. The table below shows that the maximum temperature of 123° F. in 1902 and 121° in 1903 occurred in June, the hottest throughout California. The precipitation is insignificant.

Following is a table of temperatures at Imperial, Cal., for 1902 and the first half of 1903:

*Temperature records at Imperial, Cal., 1902-3.*

Date.	Maxi- mum.	Mini- mum.	Mean.	Date.	Maxi- mum.	Mini- mum.	Mean.
	°F.	°F.	°F.		°F.	°F.	°F.
1902—January .....	84	24	55	1902—October .....	98	50	72.4
February .....	87	29	59	November .....	87	33	58.5
March .....	94	34	63	December .....	84	32	58.5
April .....	109	38	74.4	1903—January .....	83	32	57.2
May .....	113	51	81.8	February .....	94	26	60.7
June .....	123	57	89.3	March .....	104	38	65
July .....	114	51	88.1	April .....	107	50	76.2
August .....	114	62	90.1	May .....	118	51	83.5
September .....	112	54	85.6	June .....	121	66	90.5

The total rainfall for 1902 was 1.30 inches and the mean temperature for the year was 73.5° F.

### NATURAL WATERWAYS.

There are two natural waterways into Salton Sink, Alamo River, sometimes called Salton River, and New River. The Alamo receives its supply, which is during overflow only, through a number of willow-fringed channels, which collect a portion of the Colorado flood in the vicinity of and below the international boundary, in the Rancho Algodones, where thousands of acres are flooded during this period. Winding its way past Seven Wells, Gardners, and Alamo Mocho for 30

miles in Mexico, it crosses the boundary into California at Monument 218, then meandering northwest through the sand hills and in cut to Mesquite Lake, 25 miles distant, the latter acting as an equalizer of the flood flow. Thence a smaller channel leads north, winding westward below Brawley, and finally emptying into Salton Sink where the water sinks into the earth, or, spreading over the marsh, evaporates, leaving only a deposit of salt.

A portion of the overflow on the lower Colorado finds its way through the Algodones by the sluggish Rio Padrones into Volcano Lake, thence by Hardys Colorado to the Gulf of California. During the very high water of 1890 a portion of the flood found its way from Volcano Lake north past the base of the Black Buttes (the terminus of the Cocopah Mountains), in Mexico, cutting its way to the boundary at Calexico about 8 miles west of the Alamo crossing, forming Cameron and Blue lakes, cutting a deep channel west of Brawley, and finally flowing parallel to the Alamo, entering the sink near it. A considerable territory below the boundary was overflowed. Before this there had been no flow to the north for several years and the water courses were clogged with sand. The first observations of the flood were made in 1890, but not until 1900 were careful records kept. The flow for 1892 was small. The records from 1893 to 1896, inclusive, are wanting. In 1897 there was a medium flow, while for 1898 the flow was small. The flow in 1899 began July 10 and continued until September 30. In 1900 the flow was large and began about June 15. In 1901 a medium flow commenced June 6, and reached a maximum June 18. In 1903 the flow commenced June 3, with a maximum July 10, the largest since 1890.

The following measurements were made of the flow of New River in 1903:

*Gaugings of New River, 1903.*

	Cu. ft. per sec.
June 22, at No. 8 flume northwest of Imperial.....	150
June 24, 2 miles above California-Mexican boundary.....	293
June 25, 1 mile west of Blue Lake.....	238
July 10, south of Hunt line in Mexico.....	407

The measurements made in Mexico on July 10, 1903, show the maximum flow for the season. About this time the stream began to recede. The measurements made June 22 and June 25 were partially waste water from the main canal. Water ceased to flow across the boundary about July 15. The ease with which the water found its way into a barren desert, the appearance of fish and waterfowl in the lakes, and the growth of vegetation wherever water had reached caused much speculation as to the possibilities of this region. The press all over the West was writing about the flooded desert, and engineers at once organized reconnaissance parties for exploration.

**ATTEMPTS AT RECLAMATION.**

The period from 1893 to 1896 was largely one of discovery, preliminary organization, and enlistment of capital. Numerous parties were organized for various purposes. Land grabbers made desert filings and improvement companies advertised to locate settlers for a fee. The first worthy and bona fide effort at reclamation was in the formation of the Colorado River Irrigation Company, in 1893. This company organized to divert water from the Colorado below Yuma and to convey it to Salton Basin for irrigation and domestic purposes. The company never accomplished more than the preliminary surveys, owing to its failure during the financial depression of 1896. But the promise of large returns was too great to allow this enterprise to be forgotten, although there was in it a great element of risk. In a semiarid region some returns are possible without irrigation. Here every morsel of food, every article of equipment, even to drinking water, had to be freighted with teams. In spite of the risk involved and the fate of the Colorado Irrigation Company, the California Development Company was formed in 1896 to bring water to this forbidding district. The rights of the Colorado River Irrigation Company were purchased and a corps of engineers set to preparing maps and estimates. It was found necessary either to convey the water through a tunnel over 15 miles in length, north of the international boundary, or to make a long detour southward and westward through Mexico and then northward again into California. As the cost of such a tunnel was entirely beyond the means of the company, the latter course was decided upon.

Mexican law provides that only Mexican corporations shall own and control enterprises within certain distances of its borders on the Mexican side. Accordingly, a Mexican corporation was organized, and this corporation purchased 100,000 acres of land along the boundary through which the canal must pass. Concessions were obtained from the Mexican Government carrying authority to proceed, and the next step was to encourage settlement. All of the land of the valley was public up to the Southern Pacific Railroad grant, in which the railroad owned every alternate section. Title to the public land could be obtained in two ways—either by settlement under the homestead act, requiring the beginning of residence after six months and its continuance for five years to gain title to 160 acres—a thing quite impossible without water—or by filing upon 320 acres of land under the desert-land act. Under the latter law residence is not necessary, but a payment of 25 cents per acre is required when the application is filed, and satisfactory proof of the expenditure of work worth at least \$1 per acre per year for three years. To obtain a patent an additional payment of \$1 per acre is necessary, together with satisfactory proof that



one-eighth of the entire acreage has been irrigated and brought under thorough cultivation. The applicant must also prove a perpetual right to water from a reliable source, a perpetual contract with a substantial company in possession of ample supply being accepted by the Government. The California Development Company solicited settlement according to this law, the settler purchasing land from the Government and entering into a perpetual contract with the company for one share of water stock for each acre of land.

### APPROPRIATIONS FROM THE COLORADO.

There was water in the Colorado, believed to be sufficient for the irrigation of the entire delta, which, mostly below sea level, was easily irrigable by gravity. On April 25, 1899, the company posted a notice filing on 10,000 cubic feet of water per second, to be diverted at a point 1.5 miles, more or less, above the international boundary and to be conveyed in the canal to the previously described Alamo channel and by it carried through Mexico.

The drainage of the Colorado, according to the United States Geological Survey, is about 225,049 square miles. The first measurement of the discharge, made at Stones Ferry August 18, 1875, was 18,410 cubic feet per second. March 15, 1876, the discharge at Yuma was 7,659 cubic feet per second. Recent measurements made by the United States Geological Survey at Yuma are:

	Cu. ft. per sec.
July 10, 1895.....	45, 533
August 18, 1901.....	18, 683

The mean discharge for 1902 during the months of greatest use of water was:

	Cu. ft. per sec.		Cu. ft. per sec.
March.....	4, 903	July.....	45, 527
April.....	6, 179	August.....	4, 183
May.....	35, 961	September.....	3, 819
June.....	42, 520	October.....	4, 299

These measurements show that for only three of the eight months of the growing season was there in 1902 sufficient flow in the river to meet the claims filed.

The following will give an idea of the amount of water used in 1903 as determined by gaugings:

	Cu. ft. per. sec.
May 29, main canal at boundary bridge.....	492
May 30, east side below lake.....	122
June 11, Holt heading.....	27
Total.....	641

A considerable part of this 641 cubic feet per second was wasted at the time of measurement, but this amount will be utilized with the

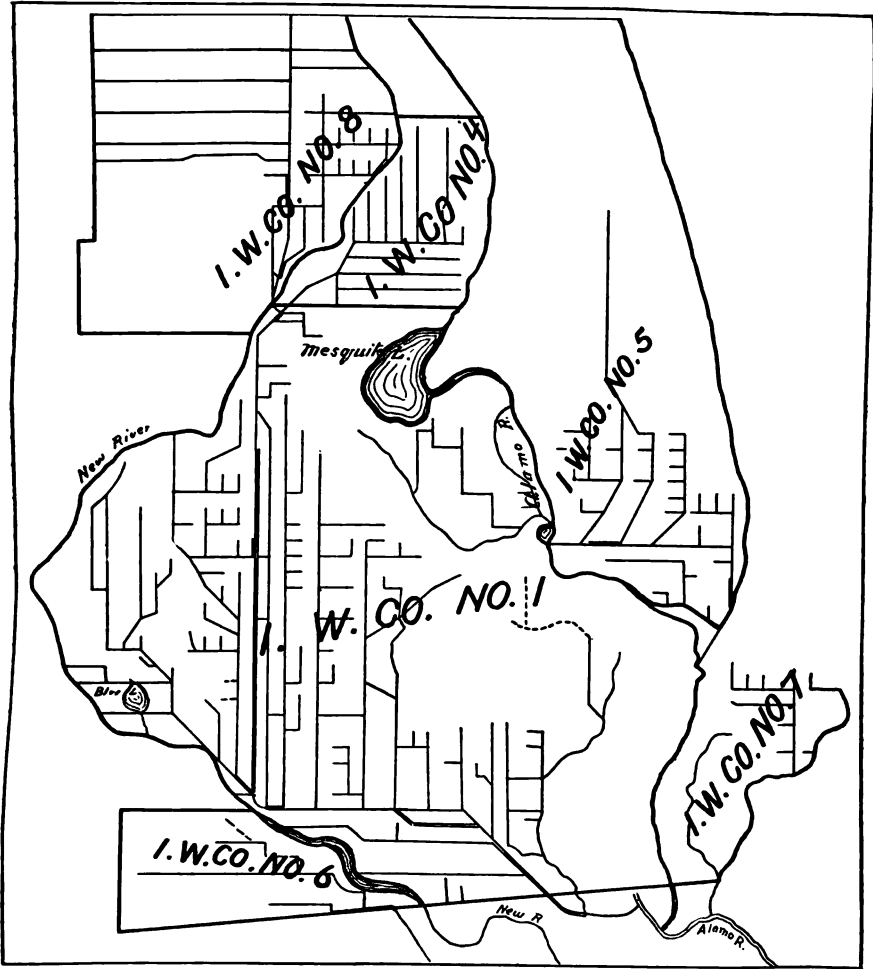

MAP OF IMPERIAL VALLEY, CALIFORNIA.



extension of the system. The largest estimated flow for 1903 was 1,428 cubic feet per second during the June flood, only a portion of which went through the Colorado heading, the remainder overflowing through the Algodones into the Alamo. In filing on so large an amount the example of a good many other companies was being followed, with a large safety factor.

### THE CANAL SYSTEM.

As seen during the summer of 1902, the canal system consisted of the temporary wooden heading at Hanlon's on the Colorado, 70 feet wide, and 8 miles of excavation and 30 miles of natural channel above the crossing at Monument 218 (map, Pl. IV). Here the system branches to supply the mutual water companies, Holt canal supplying district No. 7, a continuation of the channel furnishing district No. 5, and a large main canal supplying district No. 1 in the center, district No. 6 on the west, through the Wisteria branch, district No. 4 by an extension north, and district No. 8 by a flume over New River. The laterals as a rule follow section lines. The method adopted for naming the laterals is worthy of mention. They are usually given names of trees, each system of laterals in alphabetical order, as, Beach, Birch, Boundary; Dahlia, Date, Dogwood; Palm, Palmetto, Peach, etc. The sublaterals are numbered in order from the head gates, as, Elder No. 1, Elder No. 2, Elder No. 3, etc.

### ORGANIZATION.<sup>a</sup>

The California Development Company was incorporated in April, 1896, under the laws of New Jersey. The company diverts the water of the system from the Colorado in California, about 1.5 miles above the Mexican boundary, and at the boundary delivers it to La Sociedad de Yrrigacion y Torrenos de la Baja California, the Mexican corporation, which in turn delivers it to mutual water companies above the boundary at Sharps. These companies are similar in organization to other mutual water companies in California, and are organized to own the distributing systems that carry the water from the main canal of the California Development Company to the farmers. The Mexican company joins the California Development Company in contracting to deliver water to mutual water companies, but as all the stock of the

---

<sup>a</sup>Since this report was written the conditions of organization have changed somewhat, but are not yet settled. There have been some difficulties between the California Development Company and the settlers, due to a failure on the part of the company, owing to lack of funds, to deliver water contracted for, and to matters pertaining to the water rights of the enterprise. It is the desire of some of the settlers to have the United States Government purchase and complete the system under the reclamation act of 1901. By direction of Congress an investigation of the affairs of the enterprise is being made by the Secretary of the Interior.

Mexican Company is owned by the California Development Company the two companies are practically one, and according to the contract the mutual companies deal directly with the California Development Company. Another company, the Imperial Land Company, has been organized to act as the agent of the California Development Company in the sale of water rights, or mutual water company stock, and town sites, and to otherwise further the interests of the company and of the settlers. The mutual water companies deal with this company and with the California Development Company and the settlers deal with the mutual water companies. The capital stock of the California Development Company is \$1,250,000, which has all been issued.

### WATER RIGHTS.

To obtain water from the company's system it is first necessary to purchase a water right in the form of stock from the mutual company in whose territory the land to be irrigated is situated. Stock is sold in California only to the mutual companies, and the mutual companies sell only to landholders. Every owner of land must own as many shares of stock as he has acres of land. This is a necessary provision to prevent speculation and to insure the universal use of water.

The following is a synopsis of the joint contract between the California Development Company, Sociedad de Yrrigacion Terrenos de la Baja California, and the mutual water companies:

EXTRACT FROM THE ARTICLES OF AGREEMENT OF THE CALIFORNIA DEVELOPMENT COMPANY.

On July 24, 1901, at the city of Los Angeles, a contract was entered into between La Sociedad de Yrrigacion y Terrenos de la Baja California (Sociedad Anonima), party of the first part, organized under the laws of the Republic of Mexico, Imperial Water Company No. 1, party of the second part, organized under the laws of California, and the California Development Company, party of the third part, organized under the laws of New Jersey; wherein first party agrees upon demand of second party to perpetually deliver to second party any amount of water, not to exceed 4 acre-feet per annum for each outstanding share: *Provided, however,* That the amount to be delivered shall not exceed 400,000 acre-feet per annum, to be delivered to second party at the point on the international boundary line between the United States of America and the Republic of Mexico where main canal, constructed by first party, crosses the line, for and in consideration of 50 cents per acre-foot.

Second party agrees that the third party shall have exclusive right to collect all moneys for the sale of stock of second party as treasury stock. It is further agreed between the first and second parties that "second party shall receive and pay for not less than 1 acre-foot of water for each share of its stock outstanding upon the first day of July of each year," and that the price of 50 cents per acre-foot shall in no event be increased. In case of failure of second party to make payment, the first and third parties, or either of them, may cease to deliver water until arrearage is fully paid.

The California Development Company agrees to construct and maintain a main canal from the boundary line to the laterals of the stockholders, sufficient to supply 4 acre-feet per annum for each outstanding share of stock. In the event that the company shall fail to construct canals and convey water as agreed, second party shall

have the right to enter upon said canal and to make such enlargements and repairs as may be necessary to give sufficient capacity and shall have the right to convey water through said canal. The cost of same shall be a claim against party of the third part. The Development Company agrees to construct a system of distributing ditches in such manner as to convey the waters from said canal to a point upon each governmental subdivision of 160 acres of land, from which it is practicable to irrigate the same by gravity. Laterals and ditches as soon as completed are turned over to, and are thereafter owned and controlled by, the mutual water companies upon acceptance by an authorized representative or engineer. The amount of water to be delivered at the boundary line by first party shall be increased 2 per cent to allow for seepage and evaporation.

The term "acre-foot" of water shall be construed to mean 43,560 cubic feet of water.

The company further agrees to keep the system in good repairs, and to deliver the aforesaid amount of water, but said party shall not be held responsible for failure to deliver the water from any cause beyond its control, but shall exercise due diligence in protecting the system of canals, and in restoring and maintaining the flow of water therein.

It is finally agreed that for the faithful performance of all the terms and conditions of this agreement, severally to be performed, the first and third parties do each perpetually guarantee such performance by the other, and do severally and perpetually bind themselves to said second party that such performance be made.

This final clause results in practice in the California Development Company having the entire management of the head works and main canals in California and Mexico.

The contract is fair, concise, and positive, binding the seller and user alike, and showing good faith on the part of the Development Company.

#### **IMPERIAL WATER COMPANY NO. 1, A TYPE OF MUTUAL WATER COMPANY.**

Of the mutual water companies, Imperial Water Company No. 1 has the oldest organization, and after it have been fashioned all of the others. Therefore it will be considered in detail as a type of the mutual companies. Its present articles of incorporation, filed September 25, 1900, state the purpose of the company to be as follows:

- (1) To secure a supply of water for irrigation, domestic, and other purposes from La Sociedad de Yrrigacion y Terrenos de la Baja California (Sociedad Anonima);
- (2) to distribute water at cost to stockholders only on lands owned by them in the prescribed boundary;
- (3) to construct conduits for distribution;
- (4) to utilize power and to do any and all other acts that may be necessary in connection with the successful management of the principal objects for which the corporation is formed;
- (5) the amount of capital stock is \$1,000,000, divided into 100,000 shares of the par value of \$10 each.

The board of directors elects a superintendent, who has entire charge of the systems and their maintenance. He has personal supervision of the mains and laterals, and is the mediator between the company and the user of water. His salary is \$200 per month. His duties are arduous and require an intimate acquaintance with irrigation practice.

The zanjeros, or ditch tenders, are appointed by and are amenable to the superintendent, to whom they report daily at the office in Imperial. Each zanjero inspects his division of canal daily, observing and regulating the flow in the laterals and the amount going to each user. The zanjeros receive \$80 to \$90 per month, with a house furnished.

Imperial Water Company No. 1 has an area of nearly 100,000 acres under canals, over 2,600 of which were under irrigation in 1903. The surface of this land is in general a smooth, apparently level, gently sloping plain, admirably adapted to irrigation. Vegetation is scarce or entirely absent. By the use of parallel borders with length in the direction of the greatest slope the settlers have been able to apply irrigation with but little leveling. Exception must be made for the lands sloping to Mesquite Lake in the northeast corner, where there is a high gradient and the land is, as a rule, badly gullied. The natural situation of Mesquite Lake makes it admirably adapted for a sump into which the surplus water from the irrigated fields may flow. The canals are constructed 6 feet wide and 1.5 feet deep for 160 acres, and 14 feet wide and 1.5 feet deep for 640 acres. The company assumed that the land should receive 4 acre-inches in ten days, 1 acre-foot in thirty days, and 4 acre-feet in one hundred and twenty days. For alfalfa it is assumed that 4 acre-feet will be required during a season of eight months.

#### **COST OF WATER RIGHTS.**

To encourage settlement and also to procure needed funds for construction, the California Development Company sold stock carrying water rights in advance of its ability to deliver water. The price of this first stock was reduced from \$10 per share to \$8.75, and a further reduction was made by giving a drawback of \$3, in company bonds, for each of the first 50,000 shares issued. These bonds were receivable in payment of final installments on the stock, thus reducing the cost of the 50,000 shares to \$5.75 per share. Since these shares were sold the price of stock has been constantly on the increase. October 15, 1900, and continuing to October 1, 1901, the selling price was \$11.25. From October 1, 1903, to June 1, 1904, it was \$15. On this latter date it reached \$20, payable \$5 in cash and the balance in five yearly installments.

#### **IMPERIAL WATER COMPANY NO. 4.**

Imperial Water Company No. 4 was incorporated to irrigate 17,500 acres of land adjoining that of Imperial Water Company No. 1 on the north and including the rest of the territory between the Alamo and New rivers. Water is supplied by an extension of main canal No. 1 from a point in sec. 36, T. 16 S., R. 13 E., and known as the Bay Window. From there it flows north with a fall of 0.07 to 0.35 foot per

1,000 for 14.5 miles, then running northeast for 1.5 miles to the land watered by this company. When measured at the turn on June 4, 1903, the width was 16.6 feet and the discharge was 49 cubic feet per second. There is a deplorable lack of good canals in district No. 4. Those that are there were made with a wing plow drawn across the virgin plain and finished with the "V" scraper. As a result much trouble has been experienced and much time has been consumed in trying to sluice them out to useful form, in many cases the lateral not giving satisfaction until enlarged with other implements. The structures, too, were faulty in pattern and construction and it has usually been necessary to replace them after a considerable loss of time and expense. The land in district No. 4 is naturally adapted to irrigation, having a slope of 3 to 12 feet per mile to the northeast, with few hummocks or sand dunes and but little mesquite brush. The soil, which varies from a coarse to fine loam, with a little clay, is readily cultivable and promises large yields. The gradual slope to the Alamo makes drainage easy, when found desirable, as it probably will be in the course of time.

Centrally located in district No. 4, and 12 miles north of Imperial, is the town of Brawley, which promises to be the center of districts 4 and 8. The town is unique in its buildings, which are almost all "dobies," their material being made on the spot by turning the water from the ditch onto the place to become cellar, molding the bricks from the mixture, drying in the sun, and cementing the walls with the wet material directly from the earth. These structures, not easily affected by outside temperatures, are cool in summer and may be kept warm in winter; an overhanging roof protecting alike from the sun and erosion by rain.

#### **IMPERIAL WATER COMPANY NO. 8.**

Imperial Water Company No. 8 was formed to irrigate 40,000 acres of land on the west side of New River, northwest of Imperial and joining district No. 4 on the west. The slope is greatest to the north and the district is to be irrigated by a supply ditch running north and south, with east and west laterals every mile. The main canal, Tamarack, which was in process of construction when visited in July, 1903, is supplied by the same main as district No. 4, having its source just below the turn in section 18 in the northwest corner of district No. 1, and leading thence over New River by a 6-foot flume. It is proposed eventually to get a supply by damming New River west of Imperial. If this is done extensive flood gates must be provided to allow for the overflow from the Colorado by way of Volcano lakes, which, July 10, 1903, when measured above the boundary line, amounted to 2,678 cubic feet per second. A portion of district No. 8 is dotted with hum-



mocks 12 to 20 feet high, which it would seem could not be profitably leveled.

Imperial Water Company No. 8 is a bonded company. The Imperial Construction Company purchased from the California Development Company all the stock of Imperial Water Company No. 8 and undertook the construction of the distributing system. The water stock is paid for with the bonds of the mutual company. These bonds run for twenty years from January 1, 1903, with interest at 6 per cent per annum, payable semiannually in January and July of each year. The yearly payments begin January 1, 1908, at the rate of \$1 per share, and continue until 1923, when the final payment will be due. The Imperial Construction Company guarantees to complete the system and turn it over to Imperial Water Company No. 8 free of indebtedness other than the bonded debt of \$20 per share of stock sold. The agreement provides that besides the payment of 25 cents per acre, required by the Government as the first payment on the land, \$1 per acre shall be paid for bonds. Water Company No. 8 has been called the poor man's friend because the initial payment is small, but many settlers do not look with favor on the long protracted payments.

#### IMPERIAL WATER COMPANY NO. 6.

Imperial Water Company No. 6 was incorporated to irrigate 25,000 acres of land contiguous to the Mexican line and between New River and Signal Mountain. This body of land is supplied with water by a flume over New River at a point in Mexico known as the Z 4 crossing, whence the flow is through Wisteria canal. At the time of this inquiry there was no cultivation in district No. 6.

#### SEEPAGE.

In the arid region where irrigation is practiced the soil is, as a rule, pervious and deep, allowing the leakage or seepage from the canals and the surplus from overirrigation to sink into the sand with no harmful effects at the surface. Ordinary sand will absorb 25 to 50 per cent of its bulk of water, and if 30 to 60 feet deep, as is often the case in the great interior valleys, it is plain that an immense quantity can be stored before making its appearance on the surface. The soil conditions in Imperial Valley are unusual. The soils are clay and fine silt from Colorado River, the coarser materials carried by the river having been deposited on the higher land in Mexico. An irregularity of strata prevails on the surface and beneath. A particular type, for example a clay, may have perfectly definite limits. A common form is that which assumes the shape of a lake with a definite line of division between sand and clay. All the conditions would suggest that this was once a lake into which the silt-laden waters had

flowed until the surface was raised above the surrounding country, after which the lake was cut off from the supply stream by the shifting sand. The hard winds are a universal leveler and tend to pare down in one place and to build up in another. The less adhesive particles are rapidly carried away, leaving the clay standing above the general level. Through all of these types water seeps slowly but constantly, both horizontally and vertically. The hot sun warms the soil, tending to accelerate the flow. That which remains on the surface tends to deflocculate or destroy the porosity, reducing aeration and resulting in a stunted plant growth. The best conditions are where the soil spaces are half filled with air and half with water.

Before the building of canals water remained in Cameron and Blue lakes for long periods of time after the cessation of flow in New River in July.

In passing through the soil, water dissolves the salts, which are present in these alluvial deposits as a result of rock disintegration, from which they are derived: Evaporation of the water causes them to precipitate and to be deposited on the surface as alkali. The deposits may increase from year to year sufficiently to preclude plant growth. The results of seepage in Imperial Valley were noted particularly along several of the laterals. A deposit was found on the surface of the ground along the side of one of the canals 10 to 20 feet from the banks. The deposit had a dark, greasy appearance, and when touched to the tongue was strongly biting and corrosive. An analysis of this deposit, made by Dr. R. H. Loughridge, of the University of California, showed it to contain a high percentage of calcium chlorid, one of the most harmful salts. Similar deposits were observed on other laterals. On the east side lateral in the Holt district a portion of the canal is cut through a stiff clay, which, when wet, shows great solubility and sinks or runs together, leaving great holes. In the lower stretches of this district there is a hardpan of cemented sand which disintegrates at once when water is applied, becoming loamy, owing to the fact that the cementing material is soluble.

The losses from the canals, which in part are the cause of this deposit, were measured in a number of instances during the summer of 1903—namely, on Birch, Beach, Dahlia, Dogwood, Holt, and Rose laterals. The results of these measurements are given below:

*Seepage measurements in Imperial Valley, 1903.*

[In cubic feet per second.]

BIRCH LATERAL, JUNE 16.

Inflow: Near head gate .....	17.75
Outflow: Four miles below head gate .....	16.75
Loss in section .....	1.00
Loss per mile .....	.25
Percentage of loss .....	5.63
Percentage of loss per mile .....	1.41

## BIRCH LATERAL, JUNE 23.

Inflow: Head gate .....	24.45
Outflow: Three miles below head gate .....	23.86
Loss in section .....	.59
Loss per mile .....	.20
Percentage of loss .....	2.41
Percentage of loss per mile .....	.80

## BEACH LATERAL, JUNE 23.

The channel of Beach lateral is flat, sandy, and weedy, with 2 miles in embankment.

Inflow: Near head gate .....	7.12
Outflow: Weed's ranch, 6.5 miles below .....	4.37
Loss in section .....	2.75
Loss per mile .....	.42
Percentage of loss .....	38.62
Percentage of loss per mile .....	5.90

## DAHLIA LATERAL, JUNE 7.

The first half of the section is in a slight cut, with the remainder silted somewhat, especially in the last 2 miles.

Inflow: Near head gate .....	45.40
Outflow: 9.5 miles below .....	36.45
Loss in section .....	8.95
Loss per mile .....	.94
Percentage of loss .....	19.70
Percentage of loss per mile .....	2.07

## DOGWOOD LATERAL, JULY 8.

This lateral was in poor condition, with deposit of silt inside and levees partially weedy.

Inflow: Near head gate .....	22.60
Outflow: Six miles below .....	16.88
Loss in section .....	5.72
Loss per mile .....	.95
Percentage of loss .....	25.32
Percentage of loss per mile .....	4.22

## HOLT LATERAL, FIRST SECTION.

The soil which this lateral passes through is irregular, with strata of silt and clay.

Inflow: Below head gate .....	27.28
Outflow: Five miles below .....	24.44
Loss in section .....	2.84
Loss per mile .....	.57
Percentage of loss .....	10.00
Percentage of loss per mile .....	2.00

## HOLT LATERAL, SECOND SECTION.

The soil along this section is a coarse silt.

Inflow: Near Hickory .....	12.92
Outflow: 3.5 miles below, at Raymonds Corner .....	11.82
Loss in section .....	1.10
Loss per mile .....	.31
Percentage of loss .....	8.51
Percentage of loss per mile .....	2.40

## ROSE LATERAL, FIRST SECTION.

Inflow: Below head gate .....	36.55
Outflow: Six miles below, near Imperial Road .....	32.01
Loss in section .....	4.54
Loss per mile .....	.75
Percentage of loss .....	12.42
Percentage of loss per mile .....	2.07

## ROSE LATERAL, SECOND SECTION.

Inflow: Below head gate .....	24.54
Outflow: 4.75 miles below .....	23.32
Loss in section .....	1.22
Loss per mile .....	.26
Percentage of loss .....	4.97
Percentage of loss per mile .....	1.05

**METHODS OF LEVELING LAND.<sup>a</sup>**

The land in Imperial Valley has a uniform grade of 2 to 6 feet per mile. This would seem to be a very satisfactory grade for the application of water, but the presence of "mesquite mines," sagebrush, and greasewood on the tops of hummocks makes the land hard to level. The most satisfactory implement yet adopted for removing sagebrush is an old railroad rail bent in a V shape and hauled over the ground by a team at each end, which breaks off the shrubs or tears them out by the roots. For leveling the land, a number of kinds of implements are used, each adapted to particular conditions.

**THE SCRAPER.**

This implement is in great favor in Imperial Valley, both for leveling land and digging laterals. It is strong, portable, and has a wide range of use. It loads quickly, loses but little in hauling, and after the load is dumped, the team may be turned quickly. For the larger hummocks this is the only implement practicable.

<sup>a</sup> For a more complete description of the methods of leveling and preparing land in Imperial Valley and elsewhere, see U. S. Dept. Agr., Office of Experiment Sta. Bul. 145.

### THE LEVELER.

Where the hummocks are not high and are more or less uniform in size they can be more cheaply and more quickly smoothed by other means than by the use of the scraper. An implement in favor in Imperial Valley for this work is the rectangular leveler. This implement consists of a rectangular frame 30 feet long and 12 feet wide, made of 4 by 12 inch timbers, preferably Oregon pine. The leveler resembles a sled in construction, the 30-foot timbers corresponding to runners, and the 12-foot timbers, six in number and spaced 6 feet apart, corresponding to crosspieces. The leveler is hauled from one end, the six crosspieces, which should be shod on their wearing sides with  $\frac{3}{8}$  by 4 inch steel plates, acting as scrapers and leveling down the hummocks. The fourth crosspiece from the front is attached to hangers in such a way as to be free to be moved up and down by means of levers, by means of which this crosspiece can be made to cut more deeply than do the others. This machine weighs from 1,600 to 2,000 pounds and requires 16 horses. It is an effective implement.

### THE PLANER.

This implement is very satisfactory for use on slightly uneven ground. It is composed of a horizontal or base timber 4 by 12 inches, and a vertical back 2 by 18 inches. The timbers are held together by the extension of the steel plate with which the base is shod, and also by  $\frac{1}{4}$  by  $\frac{1}{2}$  inch straps from the toe of the base to a point near the top of the vertical back. The base is beveled toward the front and shod with plate steel to make it take dirt. Each end extends 1 foot beyond the end of the vertical portion, and to this extension is bolted a footboard. Outside of and below the footboards are the iron hangers to which the team is attached. On each footboard stands a driver of four animals, and the two drivers together govern the action of the planer. On approaching a mound the drivers stand on the forward end of the footboards, depressing the blade. As the planer moves forward a layer of earth is shaved off and gradually scattered by the drivers standing on the rear of the footboards. The team may be quickly turned and the mound again approached. The manipulation is easy, simple, and effective. The planer is of especial value in conjunction with the leveler. When the large machine has removed the brush and pared down the major part of the hummocks the remaining part may be quickly removed by the planer. In this way the land may be more cheaply prepared than by the use of the railroad iron and scraper.

### THE "A" CROWDER.

There are several devices in use for making borders or levees—the scraper, the wing plow, and the A crowder, each having particular merit. The scraper, while admirably adapted for moving earth short

distances or in slight elevation, does not have a continuous process. Besides, it lifts the dirt, when crowding or shoveling would accomplish the same result more economically. The wing plow takes advantage of this principle, crowding the dirt by means of a long moldboard. For small borders the wing plow accomplishes the same results as the scraper more cheaply and quite as satisfactorily. Although the wing plow has the advantage of continuous process, there is a considerable loss of power by the pressure against the land side to overcome the pressure of the moldboard. There is the additional objection that the wing plow makes a border which is too sharp and abrupt to travel over with machinery. The A crowder gives a continuous process, utilizes a portion of the power lost with the wing plow by compensating pressure from either side, and at the same time makes a more desirable border. The crowder is made by placing 2 by 16 inch timbers on edge with 12.5 feet between them at the front and 3.5 feet between them at the rear. This implement draws the dirt in from the strip 12.5 feet wide and leaves it in a ridge behind. On each side are three rows of vertical 4 by 4 inch timbers 4 feet long, to which the cross and angle braces are bolted, giving the strength necessary to overcome the heavy side draft in crowding the earth. Steel plates 3/4 by 6 inches line the inside along the bottom from end to end, to resist the wear from constant rubbing. At the rear is a 20-foot extension 2.5 feet wide attached to and working as a hinge on the rear of the crowder and governed by a lever. By raising and lowering this lever the top of the border may be made smooth and compact. On the front of the crowder are bolted stout wear irons, to which 14 to 16 horses are hitched. The driver rides on the front. A strip of earth along the line of the proposed levee is plowed and the crowder following makes a medium border by going over once. If a more compact levee is wanted the process is repeated. By raising the chains on the front to which the horses are hitched the height of the levee may be further increased. It is usually about 2.5 feet wide on the top and 18 inches high, with a slope of 2 to 1. A single plow in one cut fills the furrow on either side. A plat of 150 acres was provided with borders 100 feet apart in a day. For the construction of temporary borders the chain on the side which is to be the inside of the levee is fastened 12 inches from the bottom, and on the other side only 6 inches from the bottom. The machine has its greatest usefulness on long, straight borders such as are customary in Imperial Valley, where the grade is regular and gradual. The lines for the borders are usually laid out with a surveyor's instrument.

#### **THE USE OF THE SCRAPER IN MAKING LATERALS.**

In California the scraper is used almost exclusively in canal work, and the usefulness of this implement is well demonstrated by the fact

that where it is properly handled it will move the most dirt for the least amount of money and at the same time leave a channel of the best form. For the use of beginners and those not familiar with the use of this implement the following description of the method of constructing a small lateral is here inserted. The lateral described is one which was observed in the process of actual construction in Imperial Valley.

The land on the place under consideration is a fine sandy loam with a small amount of clay and a surface slope of 3 to 4 feet per mile. The ditch, when finished, is to be 6 feet wide on the bottom and 14 feet wide on the top, with banks 1.5 feet above the ground surface and ditch bottom 6 inches below the level of the ground. The banks are to be 2 feet wide on top, with inside slope of 2 feet horizontal to 1 foot vertical and outside slope of 1 foot horizontal to 1 vertical. In making the lateral the first thing to do is to lay out its position, which in Imperial Valley is done by dividing the land into squares parallel to section lines. A strip 6 feet wide is then plowed throughout the length of the lateral, which is to be the bottom. Eight feet on either side of this strip are plowed two other 6-foot sections which are to supply earth for the banks.

Now the scraper is brought into service. First a load is taken from the side section and hauled till dumped for bank. Then, while driving in the same direction, a load is taken from the middle section and dumped as a beginning of the opposite bank. The team is then turned and the process repeated, but from the opposite direction, and this working back and forth is continued until the embankments have the desired height, with all of the loose earth removed from the middle. In this way the team is kept almost constantly in useful work instead of spending a large part of the time walking back with an empty scraper for another load. If the scraper is skillfully managed the embankment will be perfectly regular and the plowed earth will all be removed from the sides and center. By dragging a V on either side of the banks any irregularities may be leveled.

### **THE USE OF WATER.**

At the time of this investigation the conditions were not auspicious for a study of the use of water. The country was new and only a small portion of the land was under irrigation. The water first ran in the laterals in June, 1900, and before this time both water and feed had to be hauled for long distances. Since the introduction of water, progress and immigration have been very rapid.

An observation of the growth of crops was made on the ranch of the Calexico Cattle Company, situated 1.5 miles northeast of Calexico, on sections 4 and 9. The soil on the ranch is a deep loam or clay of

great fertility and shows no appearance of objectionable salts. Most of the soil has no grit, which suggests that the soil particles are exceedingly fine. The water supply is had from Birch lateral. It was found impossible at this time to determine the amount of water necessary for the various crops, but observations show that the very fertile soil combined with the warm days and mild nights made the summer growth rapid and luxuriant. The fine texture of the soil, causing percolation to be slow, combined with the excessive evaporation, makes it necessary to apply water frequently, but in small amount. Any excess on the surface became so warm as to destroy vegetation.

The following table gives data as to the irrigation of crops on this ranch and notes as to their condition:

*Crop data for ranch of Calexico Cattle Company.*

Plot No.	Crop.	Number of irrigations.	Remarks.
1	Milo maize .....	6	7 feet high; heavy stalk and head.
2	Millet .....	6	4 feet high; heavy hay, giving 4 tons per acre.
3	Egyptian corn.....	4	Extra heavy stand, yielding 1.5 tons per acre, and forage for cattle; sandy soil.
4	Alfalfa .....	5	One crop of hay, 2 tons per acre; used for pasture the rest of the time; thickened much.
5	Kafir corn .....	4	4 feet high and fairly good head; not very successful.
6	Sorghum .....	5	7 feet high and good forage crop; eaten in preference to corn by cattle.
7	Egyptian corn.....	5	6 feet high with large heads; would run about 1.5 tons per acre.
8	Kafir corn .....	5	Better stand than other; 6 feet high with good heads and well-filled grain.
10	Millet .....	4	4 feet high with heavy head and good for seed or hay; eaten clean by cattle.
11	Sorghum .....	3	Three full-grown crops, 5 feet high, all grazed by cattle; old sorghum stubble.
12	Egyptian corn.....	4	Part was old stubble from year before and part resown; better than year previous, which ran 1.25 tons per acre.
13	Sorghum .....	5	Average yield of 6 feet; good stand for cattle feeding; all grazed by cattle.
14	Milo maize .....	5	Planted middle of July, which was too late for same, but made a good forage crop for cattle, and was about 4 feet high.
15	Egyptian corn.....	6	Sown early and was the heaviest crop on the ranch, or in the vicinity; ran 2 tons per acre, and the stalks left for forage; well filled.
16	Egyptian corn and sorghum.	4	Sown August 1; too late; did not head much, but made fair forage; height, 4 feet; not time to mature.
17	Milo maize .....	6	Height 10 to 12 feet; no way to average the tonnage, as it was fed to cattle, but was heavy.
18	Sorghum .....	6	7 feet high; 10 tons of stalk per acre.
19	Barley .....	3	Now has height of 20 inches and a stand which will run about 4 tons per acre when cut for hay.
20	Egyptian corn.....	3	Good stand of grain for late sowing and for the amount of irrigation given; it is the only fully matured crop made on three irrigations.
21	Millet .....		Not a success on account of too late sowing, and the water being allowed to stand on the ground after the first irrigation.

It was observed that crops require less water the second year than the first. Most crops were irrigated six times. In but one case was a crop matured with three irrigations.

### AQUATIC VEGETATION.

The canals and laterals in Imperial Valley, especially those of least grade, are subject to clogging by the aquatic growth that thrives with considerable luxuriance in the hot climate of the valley. Among the



weeds, cat-tail (*Typha latifolia*), often called tule, is by far the most troublesome in this locality. It finds an ideal habitat in the slow-flowing, silt-laden waters of the Colorado, and has been found to almost completely clog and choke a lateral in two years. The only method yet devised of clearing channels in such a condition is to stop the flow, and while the ditch bottom is still wet dig the cat-tails out with sharp shovels. A less expensive way where practical is to turn out the water, and when the ditch is dry enough mow and remove the tules and plow and scrape out the roots, and with them the collected silt. Another method of removing weeds is dragging a heavy chain up the channel, a team hitched to each end. The weeds, already bent downstream by the flow, are broken off near the roots and, floating down, are dragged out with grappling hooks as they collect in the drops below or in the small laterals. Care must be taken that the drops are kept clear to avoid backing up of the water, causing breaks in the ditch banks. In some parts of Imperial Valley the weeds on the banks are more trouble than those in the streams. If the banks are smooth and regular, the weeds can be mowed. This is necessary two or three times a season.

The users of water on the Birch lateral have organized the Birch Ditch Company for the purpose of keeping the lateral free from vegetation. The company has issued one share of stock for every acre of land, which is assessed quarterly for an amount sufficient to meet the expense incurred. The board of three directors, elected annually, elect a chairman and meet quarterly, at which time the ditch must be free of weeds, each director having in charge one-third the length. The ditch must be freed from sand bars, willows, tules, and arrowweed for a distance of 10 feet on either side from the base of the levee. The directors are paid for the time they are actually engaged in superintending the work. The constitution states that "the ditch shall be cleaned and kept clean."

# MECHANICAL TESTS OF PUMPS AND PUMPING PLANTS USED FOR IRRIGATION.

By J. N. LE CONTE,

*Assistant Professor of Mechanical Engineering, University of California.*

## INTRODUCTORY.

During the past year the division of irrigation and drainage investigations of the Office of Experiment Stations, United States Department of Agriculture, has been engaged in collecting data for the use of the irrigator on the subject of the cost of pumping water for irrigation. The work has consisted of the collection of data, first, through the medium of the mails; second, through actual mechanical tests of pumping plants in operation, and, third, through laboratory tests of several leading types of pumps.

Of these three general sources of information the second is the one principally to be depended on for the cost of power, and the first, together with general information on the market value of machinery, for the cost of installation. In every case it has been the aim to select fairly representative plants and to determine the cost of the installations complete, then to measure the quantity of water pumped per hour, the actual height through which this water is lifted, and the cost for the fuel or other source of power necessary to accomplish this. Other expenses, such as fixed charges, wear, repairs, and those due to carelessness and ignorance, have not been estimated.

The collecting of data through the medium of the mails and the actual work in the field has been carried on by Mr. A. J. Turner, formerly agent and expert of this Office. In part of this work he has been assisted by Mr. James Strachan. The laboratory tests of pumping machinery and the final collecting of results have been made by the writer. The work so far accomplished consists of the collection of data on something like 500 pumping plants scattered over the State of California. The returns from some of these are complete, from others but fragmentary; but the whole, arranged in the form of a card index, have been of great service. The work consists also of mechanical tests on 19 plants situated in the Santa Clara Valley, in the San Joaquin Valley, and in southern California near Riverside. Among these 19 plants are included some operated by gasoline engines, electric motors, and steam engines, and some using both centrifugal and plunger

pumps. Laboratory tests have been made to determine the exact efficiency, for various speeds and heads, of three of the more prominent makes of centrifugals and of one make of reciprocating pump.

### FIELD TESTS.

#### WORK PREPARATORY TO THE TESTS.

Before entering the field for the purpose of testing plants much preliminary work was necessary, which caused considerable delay. Apparatus had first to be purchased and constructed. In regard to the first item, the purchase of the following apparatus was allowed: Two steam-engine indicators with attachments for indicating gas engines and with reducing motion complete, 2 indicating wattmeters with a range from zero to 15 kilowatts at 300 volts, 1 alternating current voltmeter, one 60-pound pressure gauge, 1 vacuum gauge, one 75-foot tape, 1 speed counter, 1 level, and 2 hydrometers.

These instruments, where necessary, were calibrated. For example, the springs of the indicators were tested on the gauge-testing apparatus of the mechanical laboratory at Berkeley, and were found to be correct within the necessary limit of error. The gauges were similarly tested and a scale of corrections applied where needed. In order to be certain that their constants did not change, they were frequently checked against standard test gauges. The wattmeters are, for our purposes at least, standard, and no calibration of these is necessary.

To aid in the measurement of water in localities where it was difficult to install a permanent weir a portable weir box has been constructed. This consists of an oiled canvas box 6 feet wide, 10 feet long, and 2 feet deep, surrounded with a rim of iron pipe. A 3-foot rectangular weir is inserted in one end, and baffle plates arranged to still the water. The whole can be folded up in a form convenient for transportation.

#### METHODS PURSUED.

In making a mechanical test of a pumping plant of the ordinary type there are necessary to be known all of the following quantities: (1) The power developed within the engine or motor; (2) the amount of fuel or electrical energy used in maintaining this power for a given length of time, and, in the case of the steam engine, the amount of water evaporated in the boiler; (3) the market value of fuel or electrical energy; (4) the gauge head against which the pump operates; (5) the total measured lift of the pump; and (6) the volume of water pumped per minute or hour. The first of these is measured by the indicator in case the power is obtained from an engine, or by one or two wattmeters where the power is electrical. For a steam engine of ordinary dimensions and for some kinds of gasoline engines the indicator gives quite accurate results—quite as close as a weir is for the measurement

of water. For other kinds of gasoline engines the results are far from being good. Fortunately, however, the reading of the indicator affects in no way the final measurement of the cost of pumping, though its indications are important in showing where the losses occur. The wattmeter is a far more precise instrument than the indicator when used with an oil engine. The amount of oil used by an engine was generally measured as follows: The position of the surface of the oil in the supply tank was noted at the beginning of the test. After the test a weighed quantity of oil of the same kind was poured into the tank until the surface was brought back to the same position. The amount remaining was weighed, and this subtracted from the original amount is the weight used by the engine. The density of the oil being taken with the hydrometer, the volume can be computed. In the case of larger quantities of crude oil used in steam plants the volume was computed from the dimensions of the oil tank, and the fall in surface level, or by actual weight, and the same method is pursued to measure the water evaporated by a boiler. The gauge head pumped against was measured by the two gauges inserted at right angles to the inlet and outlet pipes of the pumps, due allowance being made for their difference in level. In certain cases where it was not possible to attach a pressure gauge, the gauge head above the pump had to be estimated from the measured lift. In a few cases where it was not possible to measure the suction lift, it had to be estimated from the vacuum-gauge readings. In regard to these two, the measured lift is of more importance, from our standpoint, than the gauge head, and similarly the oil used per hour is of more value than the indicated horsepower. If we have the quantity of fuel or electrical energy used, the measured lift, and the quantity of water pumped per minute, the most important part of our test is complete. All other measurements are intermediate and serve to show the points at which power is lost in the system. Finally, the discharge from the pump has in every test been measured with a weir. In most cases permanent weirs were placed by the parties owning the plants, so as to be used in the future for a continuous record. In some instances very good weirs were found already installed, and in others the portable weir box was used. The depths on the weirs were measured to within one-sixteenth of an inch only, further refinement not being considered necessary.

It must not be supposed that these tests are of the highest degree of accuracy. The main object was to determine, among conditions which varied to some extent, the cost of pumping water on a small scale, and a wide field had to be covered in a short time.

Difficulties were encountered in making these tests, which caused much loss of time. Many excellent plants could not be tested owing to interference with irrigation in progress. All oil and steam engines are not fitted with indicator attachments, without which a complete

test is not possible. Many pumps have no provision for attaching gauges, and often a plant can not be shut down to make changes, or the owner is not willing that such changes be made. Voltages on electric motors vary widely, and unless within the range of our wattmeters transformers have to be inserted, and these are not always obtainable. In some instances after inserting the wattmeters the power was found to be beyond the range of one of them. At one place elaborate preparations, occupying several days, were made for testing a certain large plant, but the test had to be abandoned through changes in the plans of the owners. From this it is seen that every plant is not in a position to be tested. In fact, it has required much looking about among many installations and over a wide area to find these 19 plants where nearly all required conditions could be fulfilled.

#### DESCRIPTION OF PLANTS AND RESULTS OF TESTS.

In the tabulated results, which are described below, the following terms and quantities are used:

The speed of the engine and pump is taken in revolutions per minute.

The pressure gauge is read in pounds per square inch.

The vacuum gauge is read in inches of mercury.

The discharge, suction, and total gauge heads are read in feet.

The weir is read in inches, except where the portable weir box is used, and there it is read in feet. The discharge of the weir is read in gallons per minute, the foot-gallon being equal to 231 cubic inches and weighing about 8.36 pounds.

By hydraulic horsepower is meant,

$$\frac{\text{Gallons per minute} \times \text{total gauge head} \times 62.5}{448 \times 550} = \frac{\text{gallons per minute} \times \text{h}}{3,942}$$

The area of the indicator card is taken in square inches, and its length in inches.

By the number of the indicator spring is meant that pressure per square inch which will move the pencil 1 inch on the paper.

The mean effective pressure is taken in pounds per square inch.

The indicated horsepower is the power developed within the engine cylinder.

The foot-gallon is the amount of work required to raise a gallon of water 1 foot high. It is equal to 8.36 foot-pounds. A foot-acre-foot is the amount of work required to raise an acre-foot of water 1 foot. It is equal to 2,712,000 foot-pounds.

The scale for the density of oils is the ordinary Baumé scale.

A kilowatt hour is the amount of electrical energy used in one hour when flowing at the rate of 1,000 watts.

If these definitions are borne in mind the following description of the tests will be easily understood.

## PLANTS USING GASOLINE OR OIL ENGINES.

*Plant No. 1.*—The plant owned by Mrs. S. L. Winchester, located near Campbell in the Santa Clara Valley, consists of a 35-horsepower gasoline engine, a No. 5 single-runner vertical centrifugal pump. The engine cylinder is 12 by 20 inches; speed, 210 revolutions per minute; pulley, 76 by 14 inches; belt, 12 inches. The suction and discharge openings of the pump are 5 inches in diameter, the discharge pipe 8 inches in diameter from pump to floor level, enlarging there to 12 inches in the horizontal lead to the weir box. There are two 6-inch suction pipes as shown in figure 7. The pump is direct belted with quarter-turn belt to the engine, 28 feet 3 inches between centers. The discharge was measured over a 3-foot rectangular weir, in portable weir box. Static head above pump is 60 feet (measured); static head below pump 9 feet (estimated); total mean lift, 69 feet.

This plant is a type of the great majority of pumping installations used in this district, where the gasoline engine is the source of power. Its general arrangement is shown in sketch (fig. 7). In these plants the pump is located at the bottom of a rectangular pit, whose depth is dependent on the plane of the ground water, and from which the wells, usually from 1 to 6 in number, are sunk. These wells are usually from 150 to 250 feet in depth, and cased with perforated casing.

The suction pipes are about 40 feet long, and should be considerably larger than the pump inlet. The check valve is placed immediately above the discharge opening, and the discharge pipe increased from one and one-half to twice the diameter of the opening. The shaft is vertical and supported at intervals by bearings. The engine is belted with a single quarter-turn belt, which is the best possible arrangement under the circumstances. The general arrangement of machinery here shown is perhaps the best, where the vertical centrifugal pump is used, and providing the pump is running at its proper speed good efficiency may be expected.

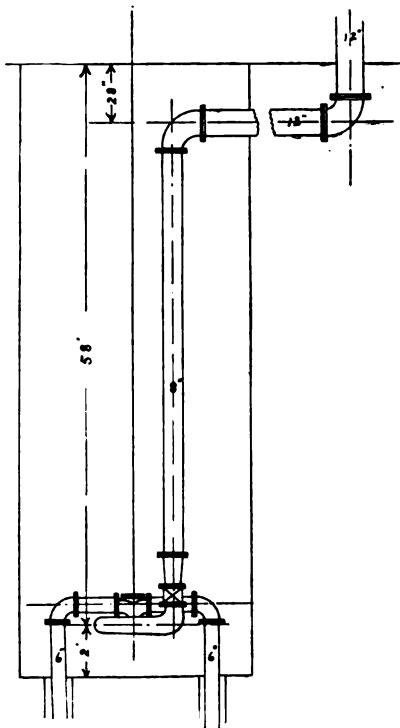

FIG. 7.—Plan of pumping plant owned by Mrs. S. L. Winchester.

The results of the test of this plant are given in the following table:

*Test of plant No. 1, owned by Mrs. S. L. Winchester, March 16, 1904.*

Time.	Revolutions per minute.		Dis-charge head.	Suction head.	Total head.	Gallons per minute.	Hy-draulic horse-power.	Mean effective pressure, No. 120 spring.	Explosions per minute.	Indi-cated horse-power.
	En-gine.	Pump.								
10.40 .....	210	700	63.1	12.8	75.9	980	18.8	Pounds.		
11.00 .....	212	730	63.1	12.8	75.9	980	18.8	62.8	102	36.6
11.20 .....	210	722	63.1	13	76.1	984	19	62.1	105	37.3
11.40 .....	210	723	63.1	13.1	76.2	988	19	62.4	105	37.4
Shut down.								64.2	104	38.2
1.30 .....	216	726	63.1	13.1	76.2	984	18.9	57.9	108	35.7
1.50 .....	216	727	63.1	13.5	76.6	988	19.1	56.5	107	34.5
2.10 .....	216	727	63.1	13.5	76.6	988	19.1	59.3	108	36.6
2.30 .....	216	727	63.1	13.6	76.7	969	17.3	61.4	102	35.8
2.60 .....	216	725	63.1	13.7	76.8	980	19	65	100	37.1
3.10 .....	216	725	63.1	13.5	76.6	980	19	56.9	102	33.1
3.30 .....	216	727	63.1	13.6	76.7	975	19	64.8	99	36.6
3.50 .....	216	724	63.1	13.6	76.7	975	19	65.8	100	37.6
4.10 .....	216	730	63.1	13.7	76.8	975	18.9	58.7	103	31.5
4.30 .....	216	724	68.1	13.7	76.8	975	18.9	66.8	104	39.6
Average..	214	724	63.1	13.4	76.5	980	18.9	61.8	104	36.57

The combined efficiency of engine and pump was 51.7 per cent. The oil used was 48° engine distillate, costing 11.5 cents per gallon at the warehouse or 12 cents delivered; density, 0.794; total oil used, 149.5 pounds in four hours—22.6 gallons in four hours, or 5.65 gallons per hour and 0.155 gallon per indicated horse-power hour. At 12 cents per gallon the cost of fuel is 67.8 cents per hour. The total mean lift of the pump being 69 feet, and the quantity of water pumped per minute being 980 gallons, the total amount pumped per hour is 58,800 gallons, and the useful work done in an hour 4,058,000 foot-gallons, at a cost of 67.8 cents. Hence the cost per 1,000,000 foot-gallons is 16.7 cents; the oil per 1,000,000 foot-gallons is 1.39 gallons; the cost per foot-acre-foot is 5.42 cents; and the oil per foot-acre-foot is 0.45 gallon.

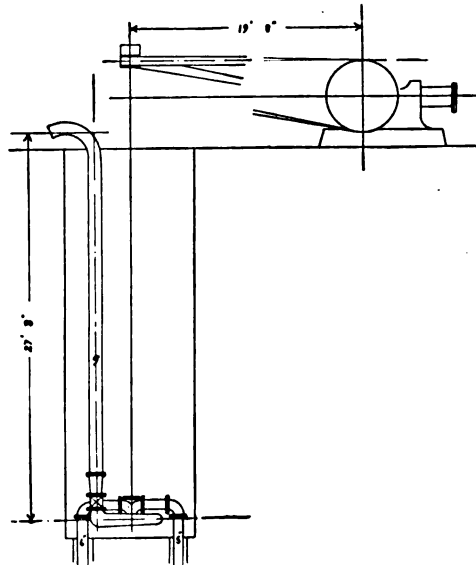

FIG. 8.—Plan of pumping plant owned by J. C. Lewis.

A plant of this type requires little expense for attendance, the attendant doing other work most of the time. The cost of the installation (1895) is said to have been \$3,000.

*Plant No. 2.*—The plant owned by J. C. Lewis is located at Edenville, in the Santa Clara Valley. It consists of a 22-horsepower gaso-

line engine and a No. 5 single-runner vertical centrifugal pump. The engine cylinder is 11 by 12 inches; speed 240 revolutions per minute; pulley 31 by 10 inches, and belt 9 inches. The suction and discharge openings of the pump are 5 inches; discharge pipe 9 inches throughout; two suction pipes 5 and 6 inches in diameter. The pump is direct belted with quarter-turn belt to engine, 19 feet 8 inches between centers. The water is measured over a 2.5-foot Cipolletti weir put in for test and left in place. The static head above pump is 27 feet 8 inches (measured); the static head below pump is 3 feet (estimated); the total mean lift, 31 feet. This plant is practically identical in general arrangement with the preceding one. The discharge pipe empties directly into the flume and therefore presents no sharp turns to obstruct the stream. The suction head is remarkably low; in fact, the pump is often completely submerged when not in use. The sketch (fig. 8) shows the main features.

The results of the test are given in the following table:

*Test of plant No. 2, owned by J. C. Lewis, April 25, 1904.*

Time.	Revolutions per minute.		Discharge head.	Suction head.	Total head.	Gallons per minute.	Hydraulic horsepower.	Mean effective pressure. No. 120 spring.	Explosions per minute.	Indicated horsepower.
	Engine.	Pump.								
			<i>Feet.</i>	<i>Feet.</i>	<i>Feet.</i>			<i>Pounds.</i>		
1. 30 .....	239	690	28.3	5.1	33.4	831	.....	38.5	119.5	13.2
2. 00 .....	239	692	28.3	4.9	33.2	816	.....	39.8	119.5	13.7
2. 30 .....	239	690	28.3	4.9	33.2	796	.....	39.8	119.5	13.7
2. 45 .....	238	688	28.3	7	35.3	796	.....	39.6	119	13.6
3. 00 .....	239	690	28.3	7	35.3	796	.....	38.8	120	13.4
3. 15 .....	238	690	28.3	7	35.3	796	.....	39.6	119	13.6
3. 30 .....	238	690	28.3	7.2	35.4	796	.....	38.9	119	13.3
3. 45 .....	238	690	28.3	7.4	35.7	796	.....	39	119	13.4
4. 00 .....	238	690	28.3	7.4	35.7	796	.....	38	119	13
4. 15 .....	238	690	28.3	7.4	35.7	796	.....	38.8	119	13.3
4. 30 .....	238	690	28.3	7.4	35.7	796	.....	38.8	119	13.3
Average	238.4	690	28.3	6.6	34.9	801	.....	39.6	119.2	13.41

The combined efficiency of engine and pump is 52.2 per cent. The oil used was 44° engine distillate, costing 11.5 cents per gallon; density, 0.811. The total oil used was 5.84 gallons in three hours, or 1.95 gallons per hour and 0.145 gallon per indicated horsepower hour. At 11.5 cents per gallon the cost of fuel is 22.4 cents per hour. The total mean lift being 31 feet and the quantity per minute pumped being 796 gallons, the useful work per hour was 1,480,000 foot-gallons, at a cost of 22.4 cents. Hence the cost per 1,000,000 foot-gallons was 15.1 cents, the oil per 1,000,000 foot-gallons was 1.31 gallons, the cost per foot-acre-foot was 4.9 cents, and the oil per foot-acre-foot was 0.42 gallon. For purposes of comparison, taking the cost of fuel at 12 cents per gallon, these figures become: Cost per 1,000,000 foot-gallons, 15.8 cents; cost per foot-acre-foot, 5.12 cents.

The efficiency of this plant is practically the same as that of No. 1. The two are of particular interest as showing the results obtained from



a low-lift and a medium high-lift plant, using practically identical machinery.

*Plant No. 3.*—The plant owned by William Bogen, located at Englewood Ranch, near Campbell, Santa Clara Valley, consists of a gasoline engine and a No. 4 compound double-runner vertical centrifugal pump. The engine cylinder is 11.5 by 18 inches; speed, 190 revolutions per minute; pulley, 30 inches in diameter. The suction and discharge openings of the pump are 4 inches; discharge pipe, 7-inch casing throughout, with one short-radius elbow. There are two suction pipes, 5 inches in diameter, fitted with short-radius elbows. The engine is belted straight to a 36-inch pulley on a jack shaft. The

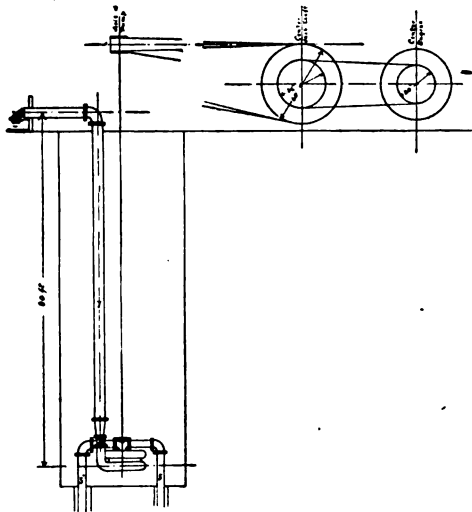

FIG. 9.—Plan of pumping plant owned by William Bogen.

pump is belted with quarter-turn belt to 60-inch pulley on jack shaft (fig. 9); the pump pulley is 12 inches.

The water was measured over a 3-foot rectangular weir in portable weir box during the test. A 24½-inch Cipolletti weir was placed by our party March 22, 1904. The static head above pump was 80 feet (measured); the static head below pump, 9 feet (measured); total mean lift, 89 feet. The general arrangement of machinery is indicated in figure 9. The installation of the pump is

practically the same as in No. 1, but the engine is belted to a jack shaft, and this to the pump, presumably to get the proper speed on the latter. The suction head is low.

The results of the test are given in the following table:

*Test of plant No. 3, owned by William Bogen, March 21, 1904.*

Time.	Revolutions per minute.		Discharge head.	Suction head.	Total head.	Gallons per minute.	Hydraulic horse-power.	Mean effective pressure, No. 120 spring.	Explosions per minute.	Indicated horse-power.	
	Engine.	Pump.									
			<i>Feet.</i>	<i>Feet.</i>	<i>Feet.</i>			<i>Pounds.</i>			
11. 35 .....	189	730	78.8	12.6	91.4	341	.....	50	94	22.2	
12. 25 .....	189	730	78.8	13.7	92.6	330	.....	60.2	75	21.3	
12. 45 .....	183	747	78.8	14.2	92.9	336	.....	58.7	74	20.5	
1. 05 .....	183	747	78.8	14.4	93.2	336	.....	58	78	21.4	
1. 25 .....	189	757	78.8	14.6	93.3	336	.....	48.2	85	19.4	
2. 05 .....	187	760	78.8	14.6	94.3	347	.....	50.1	80	18.9	
2. 25 .....	187	765	78.8	15.1	93.9	347	.....	47.5	86	19.3	
2. 45 .....	187	762	78.8	15.3	94.1	344	.....	48.5	80	18.3	
3. 05 .....	188	760	78.8	15.6	94.3	336	.....	55	80	20.8	
3. 25 .....	188	760	78.8	15.9	94.7	333	.....	53.8	80	20.3	
Average..	187	752	78.8	14.6	93.47	338	.....	8.01	53	81.2	20.24

The combined efficiency of engine and pump is 39 per cent. The oil used was 48° distillate, costing 11.5 cents at the warehouse, or 12 cents per gallon delivered; density, 0.794. The total oil used was 14.43 gallons in three hours fifty minutes, or 3.76 gallons per hour, and 0.186 gallon per indicated horsepower hour. At 12 cents per gallon the cost of fuel is 45.1 cents per hour. Taking the total lift at 89 feet and the quantity of water pumped at 338 gallons per minute, the useful work done in an hour was 1,808,000 foot-gallons, costing for fuel 45.1 cents. Hence the cost per 1,000,000 foot-gallons was 25 cents; oil per 1,000,000 foot-gallons 2.08 gallons; cost per foot-acre-foot 8.11 cents, and oil per foot-acre-foot 0.67 gallon.

The comparatively great expense of operating this plant is due to several causes. In the first place the amount of oil used by the engine is excessive (0.186 gallon per indicated horsepower per hour). The intervention of the jack shaft in the belting scheme is a bad one, and wastes a great deal of power. Furthermore, short-radius elbows are not to be used except where absolutely necessary, and also the water is lifted a foot too high. Finally, the smaller size of pump (No. 4) can not give as high an efficiency as the No. 5 pumps of the preceding tests, other things being equal. There appears to be no good reason why a single pulley 50 inches in diameter on the engine and a direct quarter-turn belt could not have been included in the original design. Leaving out of account any possible error in the design of this class of pump, it is evident that if this plant operated at an efficiency equal to the two preceding, the cost for fuel would not have exceeded 29 cents per hour. In other words, the loss per hour due to this cause is 16 cents, which in a month of continuous running (ten hours per day for twenty-six days) amounts to \$41.50.

The cost of this installation complete is said to have been \$3,500.

*Plant No. 4.*—The plant owned by S. K. Jackson, Santa Clara Valley, consists of a 25-horsepower gasoline engine and a No. 4 single-runner vertical centrifugal pump. The engine cylinder is 12 by 17 inches; speed, 190 revolutions per minute; pulley, 60 inches diameter; and belt, 8 inches. The inlet and outlet openings of the pump are 4 inches in diameter, discharge pipe 7¼ inches throughout, with one 90° elbow. There are two suction pipes, 4 inches in diameter. The pump is direct belted to engine with quarter-turn belt. The water is measured over a 24-inch Cipolletti weir put in for test and left in place. The static head above the pump is 53 feet 7 inches (measured); the static head below pump 26 feet (measured); total mean lift about 80 feet.

This plant is similar in all respects, except size and make of pump and engine to No. 1, and therefore no sketch is shown. In running this test trouble was occasioned by hot crank-pin brasses, which necessitated a shut down from 1.33 to 1.57 p. m.

The results of the test are given in the following table:

*Test of plant No. 4, owned by S. K. Jackson, April 19, 1904.*

Time.	Revolutions per minute.		Discharge head.	Suction head.	Total head.	Gallons per minute.	Hydraulic horsepower.	Mean effective pressure, No. 120 spring.	Explosions per minute.	Indicated horsepower.
	Engine.	Pump.								
11.15 .....	172	970	<i>Feet.</i> 64.5	<i>Feet.</i> 23.8	<i>Feet.</i> 78.3	378	7.5	<i>Pounds.</i> 53.4	86	23
11.45 .....	182	988	54.6	27.2	81.8	451	9.3	57.9	91	25
12.15 .....	177	972	54.6	26.1	80.7	402	8.2	55.8	88.5	23.4
12.45 .....	186	1,000	54.6	30.6	85.2	476	10.2	51.6	93	22.8
1.05 .....	188	1,004	54.6	30	84.6	451	9.6	54.0	94	24.1
2.15 .....	182	983	54.6	27.2	81.8	402	8.3	50.4	91	21.8
2.45 .....	184	990	54.6	28.6	83.2	426	8.9	52.8	92	23.1
Average..	182	987	54.6	27.6	82.2	426.6	8.89	53.7	90.8	23.31

The combined efficiency of engine and pump was 45 per cent. The oil used was 49° distillate, costing 10.5 cents per gallon; density, 0.790. The total oil used was 10.59 gallons in three hours and twenty-six minutes, or 3.086 gallons per hour and 0.132 gallon per indicated horsepower per hour. At 10.5 cents per gallon the cost per hour for fuel is 32.4 cents. The total mean lift being 80 feet and the quantity of water pumped per minute being 427 gallons, the useful work in an hour is 2,050,000 foot-gallons, at a cost of 32.4 cents. Hence, cost per 1,000,000 foot-gallons is 15.8 cents; oil per 1,000,000 foot-gallons, 1.5 gallons; cost per foot-acre-foot, 5.15 cents, and oil per

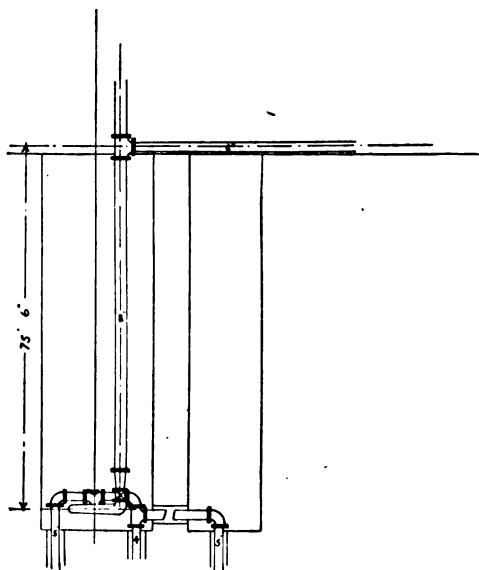

FIG. 10.—Plan of pumping plant owned by S. H. Shelley.

foot-acre-foot 0.49 gallon. Using distillate at the uniform price of 12 cents, these figures become: Cost per 1,000,000 foot-gallons, 18 cents; cost per foot-acre-foot, 5.84 cents. Further information furnished by the owner of the plant develops the fact that he is accustomed to use a tank of from 108 to 109 gallons during thirty-six hours' run. This is at the rate of 3.02 gallons per hour, a result practically identical with the test. The following are said to be the costs of the installation: Engine, \$1,200; pump, with shaft, \$300; wells, \$800; erection and building, \$200; total, \$2,500.

*Plant No. 5.*—This plant, owned by S. H. Shelley, Santa Clara Valley, consists of a 19-horsepower gas engine, furnished with a retort and a No. 4 single-runner vertical centrifugal pump. The engine cylinder is 8.5 by 15 inches; speed, 240 revolutions per minute; pulley, 48 inches in diameter; belt, 8 inches. The inlet and outlet pipes of the pump are 4 inches in diameter; the discharge pipe, 8 inches in diameter to flume, but with 6-inch side outlet 5 feet long to weir box. This latter was used on test. There are three suction pipes, two 5 inches in diameter and one 4 inches in diameter, as shown in sketch (fig. 10). The pump is direct connected with quarter-turn belt to engine, with 32 feet between centers. The water was measured over a 16-inch rectangular weir put in for test and left in place. The static head above pump is 75 feet 6 inches (measured); the static head below pump, 12 feet (measured); the total mean lift, 87 feet 6 inches.

This pump was worn and leaking, due to bad usage and badly balanced runner, which caused heating and wear within the pump. When not running the pump was covered with water, and when running it was not easy to insert a pressure gauge at the pump on account of high pressure. The vacuum-gauge connection was already in, but the gauge head on the discharge had to be estimated from the measured head and frictional losses.

The results of the test are given in the following table:

*Test of plant No. 5, owned by S. H. Shelley, May 4, 1904.*

Time.	Revolutions per minute		Discharge head.	Suction head.	Total head.	Gallons per minute.	Hydraulic horsepower.	Mean effective pressure, No. 120 spring.	Explosions per minute.	Indicated horsepower.
	Engine.	Pump.								
			<i>Feet.</i>	<i>Feet.</i>	<i>Feet</i>			<i>Pounds.</i>		
10.27 .....	226	820	76	8.8	84.8	226	4.8	72.3	113	17.6
11.00 .....	228	830	76	9.4	85.4	247	5.3	78.6	114	19.4
11.20 .....	236	836	76	10.9	86.9	247	5.4	77.1	118	19.6
11.40 .....	227	823	76	11.2	87.2	247	5.4	75.7	113.5	18.5
12.00 .....	229	822	76	10.8	86.8	240	5.3	72.4	114.5	17.9
12.20 .....	236	836	76	10.9	86.9	247	5.4	72.7	118	18.5
12.40 .....	236	836	76	10.9	86.9	247	5.4			
1.00 .....	226	820	76	10.9	86.9	247	5.4	72.7	118	18.5
1.20 .....	230	829	76	10.1	86.1	240	5.2	74.0	115	18.3
1.40 .....	234	838	76	11.5	87.4	247	5.5	78.1	117	19.7
2.00 .....	228	832	76	11.6	87.6	247	5.5	74.8	114	18.4
2.20 .....	229	828	76	11.7	87.7	247	5.5	75.2	114.5	18.6
2.40 .....	230	830	76	11.8	87.8	233	5.3	76.8	115	19
3.00 .....	228	827	76	11.3	87.3	240	5.3	74.1	114	18.2
3.20 .....	230	836	76	12.1	88.1	255	5.7	74.5	115	18.5
3.40 .....	230	836	76	11.9	87.9	233	5.2	76.6	115	19
4.00 .....	228	823	76	10.4	86.4	138	3.0	a 78.8	114	19.5
4.20 .....	232	830	76	10.2	86.2	151	3.3	a 72.9	116	18.2
4.40 .....	225	812	76	9.5	85.5	184	4.0	a 73.5	112.5	17.2
4.57 .....	232	822	76	10.1	86.8	225	4.9	a 72.3	116	18.1
Average..	230	828.3	76	10.8	86.8	229	5.04	74.9	115.1	18.56

a No. 200 spring.

The combined efficiency of engine and pump is 27 per cent. The oil used was 36.8° Coalinga oil, costing but 5 cents a gallon. It is understood that this kind of oil is no longer on the market; density, 0.845.

The total oil used was 126 pounds in six and one-half hours; 17.89 gallons in six and one-half hours, or 2.75 gallons per hour and 0.148 gallon per indicated horsepower per hour. At 5 cents per gallon, the cost of fuel is 13.75 cents per hour. Taking the total mean lift at 87 feet, and the discharge at 229 gallons per minute, the useful work done in an hour is 1,196,000 foot-gallons at a cost of 13.75 cents. Hence we have: Cost per 1,000,000 foot-gallons, 11.5 cents; oil per 1,000,000 foot-gallons, 2.3 gallons; cost per foot-acre-foot, 3.73 cents, and oil per foot-acre-foot, 0.75 gallon. The low cost in this case is entirely due to the cheapness of the fuel used, for otherwise the performance of the plant is exceptionally poor. It can not be stated without a test what efficiency the plant would give with the 12-cent distillate used in some of the others, but assuming it to be the same, since the engine was in no way responsible for the bad showing, the cost per hour for operating the plant would be 33 cents. This gives, cost per 1,000,000 foot-gallons, 27.6 cents; cost per foot-acre-foot, 9 cents.

The comparatively low efficiency of this plant is due to several causes, the principal one of which is the bad condition of the pump itself. Being badly worn, it probably leaked air at the stuffing box, a state of affairs fatal to good efficiency. Again, there was heating within the pump, due to the failure of the water balance to work properly, causing a loss of energy. The piping of the suction also might have been improved upon by inserting the "tee" (see fig. 10) in the horizontal instead of in the vertical branch. The plant has, since this test, been overhauled and put in good condition.

*Plant No. 6.*—This plant is owned by S. H. Shelley, Maybury road, near San Jose, Santa Clara Valley. It consists of a 19-horsepower gas engine and a retort, and a No. 5 single-runner vertical centrifugal pump. The engine cylinder is 8.5 by 15 inches; speed, 220 revolutions per minute; pulley, 39 inches in diameter. The inlet and outlet pipes of the pump are 5 inches in diameter; the discharge pipe 8 inches throughout, with one long-radius elbow. There are two 5-inch suction pipes. The pump is direct belted with quarter-turn belt to engine, with 26 feet between centers. The water was measured over a 2.5-foot Cipolletti weir put in for the test and left in place. The static head above the pump is 52 feet 4 inches (measured); the static head below pump, 4 feet (measured); and the total mean lift about 56 feet. This plant is similar in arrangement to No. 1, and therefore no sketch is appended. Having a low suction lift and larger pump with exactly similar engine and fuel, we should expect better results than in the preceding. The results of the test are given in the table following.

Test of plant No. 6, owned by S. H. Shelley, May 7, 1904.

Time.	Revolutions per minute.		Discharge head.	Suction head.	Total head.	Gallons per minute.	Hydraulic horsepower.	Mean effective pressure, No. 120 spring.	Explosions per minute.	Indicated horsepower.
	Engine.	Pump.								
			<i>Feet.</i>	<i>Feet.</i>	<i>Feet.</i>			<i>Pounds.</i>		
12.00	224	700	53.7	3.7	57.4			76.5	112	
12.20	224	708	53.7	4.1	57.8			76.2	112	
12.40	224	708	53.7	4.1	57.8			78.1	112	
1.00	224	708	53.7	4.2	57.9			78.9	112	
1.20	224	714	53.7	4.3	58			78.4	112	
1.40	219	706	53.7	3.7	57.4			81	109.5	
2.00	218	700	53.7	4	57.7			78.2	109	
2.20	220	701	53.7	3.5	57.2			78.2	110	
2.40	220	709	53.7	3.7	57.4			80.3	110	
3.00	216	696	53.7	3.1	56.8			82.3	108	
3.20	224	702	53.7	4.1	57.8			78.7	112	
3.40	224	700	53.7	4.1	57.8			81.7	112	
4.00	226	719	53.7	4.2	57.9			79	113	
4.20	230	727	53.7	4.2	57.9			78.2	115	
4.40	230	730	53.7	4.2	57.9			83	115	
5.00	226	721	53.7	4.2	57.9			83.6	113	
5.20	230	727	53.7	5.7	59.4			78.1	116	
5.40	226	717	53.7	6.1	59.8			78.1	113	
Average..	224	710.1	53.7	4.2	57.88	444.1	6.53	79.36	111.9	19.09

a No. 200 spring.

The combined efficiency of engine and pump is 34 per cent. The oil used was 36.7° Coalinga distillate, costing 5 cents per gallon (same as No. 5); density, 0.846. The total oil used, 14.04 gallons in six hours, or 2.34 gallons per hour, and 0.122 gallon per indicated horsepower per hour. At 5 cents per gallon the cost per hour for fuel is 11.7 cents. From the total mean lift of 56 feet and mean discharge of 444 gallons per minute we find that the work done per hour was 1,499,000 foot-gallons, at a cost of 11.7 cents. Hence the cost per 1,000,000 foot-gallons was 7.84 cents; oil per 1,000,000 foot-gallons, 1.57 gallons; cost per foot-acre-foot, 2.54 cents, and oil per foot-acre-foot, 0.51 gallon. Of course the extremely low cost is due principally to the cheap fuel. Putting it approximately on the 12-cent per gallon basis, as in the preceding case, we find the cost per 1,000,000 foot-gallons 18.8 cents, and the cost per foot-acre-foot, 6.1 cents—not as good a showing as made by Nos. 1 and 2. This plant gives a very fair result. The performance of the engine is excellent, for we find but few engines fulfilling their guarantees (one-eighth gallon per brake horsepower per hour) after being in service, and pretty severe service at that, for several years.

*Plant No. 7.*—This plant, owned by Darrell & Schumacker, Manchester avenue, Los Angeles, consists of a 22-horsepower gasoline engine and a No. 6 single-runner vertical centrifugal pump. The engine cylinder is 10.5 by 18 inches; the speed, 200 revolutions per minute; pulley, 40 inches in diameter; belt, 10 inches. The inlet and outlet openings of the pump are 6 inches in diameter; discharge pipe, 7 inches outside diameter, casing direct to flume without elbow. There are two suction pipes, 6 inches in diameter, with long-radius screwed

elbows. The pump is direct belted, with quarter-turn belt to engine, with 10-inch pulley, 26 feet between centers (fig. 11). The water was measured over a 24-inch Cipolletti weir put in for the test and left in place. The static head above the pump is 20 feet (measured); the static head below pump is 11 feet (measured), and the total mean lift,

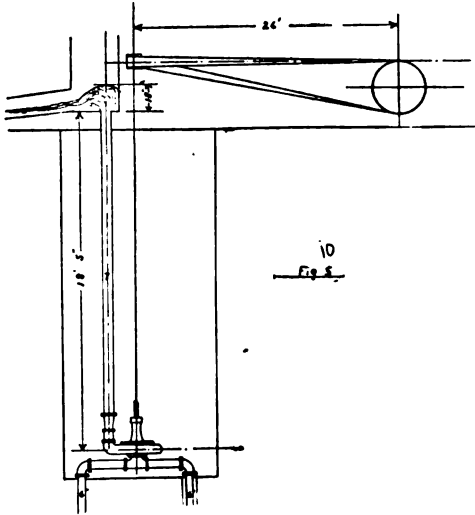

FIG. 11.—Plan of pumping plant owned by Darrell & Schumacker.

31 feet. The test on this plant is incomplete on account of the fact that our party was not allowed to measure the oil. All that could be obtained on the subject of oil consumption was gathered from the attendant, who stated on one occasion that 2 gallons per hour were used, and on another that one-eighth gallon per horsepower hour was the consumption. The former is evidently but a rough approximation, and the latter is probably the builder's rating. Furthermore, it was not practicable to insert a

gauge on the pressure side, but this necessary omission does not in any way affect the final or gross efficiency. The gauge head has been taken as the static lift plus the computed losses.

The results of the test are given in the following table:

*Test of plant No. 7, owned by Darrell & Schumacker, June 11, 1904.*

Time.	Revolutions per minute.		Dis-charge head.	Suction head.	Total head.	Gallons per minute.	Hy-draulic horse-power.	Mean effective pressure, No. 120 Spring.	Explosions per minute.	Indi-cated horse-power.
	Engine.	Pump.								
			<i>Feet.</i>	<i>Feet.</i>	<i>Feet.</i>			<i>Pounds.</i>		
10.50 .....	198	750	21	13.0	34 0	665	.....	64	67	.....
11.00 .....	198	749	21	13.8	34.8	665	.....	71.6	53	.....
11.15 .....	198	749	21	13.8	34.8	782	.....	66.2	50	.....
11.30 .....	198	755	21	14.2	35.2	782	.....	74.1	50	.....
11.45 .....	198	755	21	14.3	35.3	782	.....	77.9	49	.....
12.00 .....	198	755	21	14.6	35.6	753	.....	78.6	49	.....
12 15 .....	198	762	21	11.3	32.3	694	.....	77.4	49	.....
12 30 .....	198	760	21	11.3	32.3	694	.....	67.8	53	.....
Average..	198	751	21	13.3	34 3	727	6.32	72.2	52.5	18.29

The combined efficiency of engine and pump is 34.5 per cent. The oil used was 44° engine distillate, costing 10.5 cents per gallon; density, 0.811. The consumption taken at 0.13 gallons per indicated horsepower per hour,<sup>a</sup> gives 2.38 gallons per hour used, costing 25 cents per

<sup>a</sup> Average consumption shown on previous tests.

hour. The useful work was 1,351,000 foot-gallons in one hour. Hence the cost per 1,000,000 foot-gallons was 18.5 cents; oil per 1,000,000 foot-gallons, 1.76 gallons; cost per foot-acre-foot, 6 cents; oil per foot-acre-foot, 0.57 gallon. With distillate at 12 cents per gallon these become: Cost per 1,000,000 foot-gallons, 22.2 cents; cost per foot-acre-foot, 7.2 cents. No great reliance can be placed upon these results, as the oil was not actually measured. The low combined efficiency, no doubt, is partly due to the small discharge pipe, which

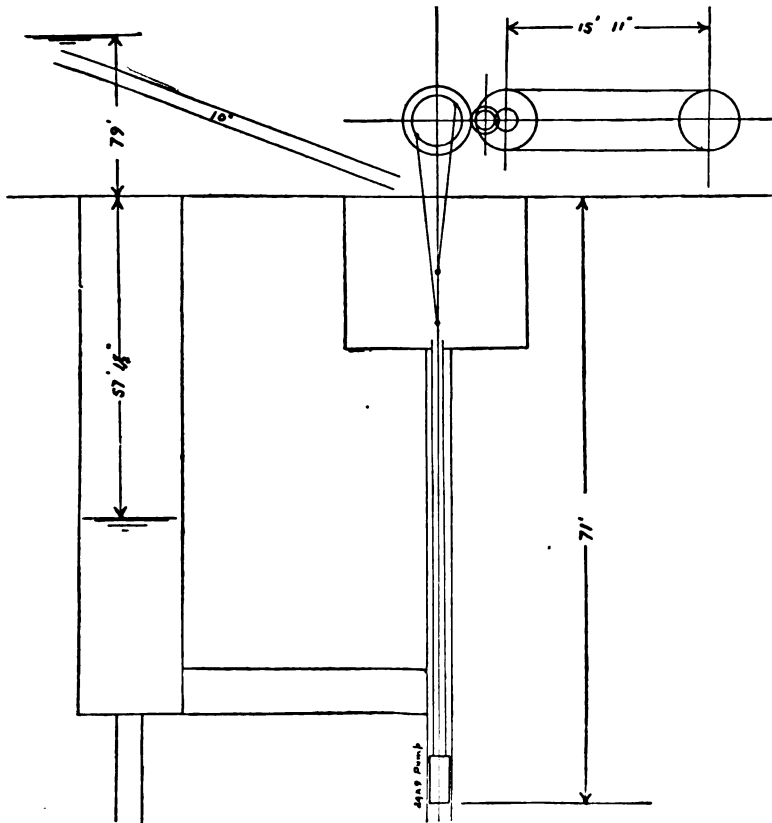

FIG. 12 — Plan of Hermosa pumping plant, Portersville, Cal.

is but five-eighth inch larger than the pump outlet. It should have been 8 or 10 inches in diameter, connected with taper fittings.

*Plant No. 8.*—The Hermosa plant, at Portersville, San Joaquin Valley, consists of a 30-horsepower gasoline engine, and a deep well piston pump (fig. 12). The engine cylinder is 10 by 16 inches; the speed, 270 revolutions per minute; pulley, 28 inches in diameter; the belt, 9 inches. The pump is a double-acting piston pump, two pistons working on two rods. An overlapping stroke on the pistons is obtained by means of noncircular gearing. The pump barrel is 9



by 24 inches. The discharge pipe is 10 inches in diameter; there is no suction pipe, as the pump is operated below water. The pump is belted direct to engine, with 16-foot centers. The water is measured over a 16-inch rectangular weir put in for the test and left in place. The total mean lift is 145 feet (measured). This pump discharges its water through 1,020 feet of redwood pipe, and therefore the test is not quite a fair comparison with those on preceding plants, for the reason that it not only has to lift the water, but also transports it 1,020 feet, encountering frictional resistance the whole way. Inasmuch, however, as the pipe is large (10 inches in diameter) and the velocity small (1.6 feet per second), the friction head will be small—smaller, in fact, than in most direct-lift plants. We therefore insert it in direct comparison with others. The engine appeared to be overrated, because it was just possible to keep it up to its work, and the brasses heated badly. The belt centers were also too short. It was intended to run the engine on crude oil, but this was found so unsatisfactory with the retort used that the attempt was abandoned and distillate substituted.

The wells are two in number, sunk in the bottom of two pits. The main pit is 6 feet deep, and from it a 12-inch well is sunk. This contains the pump, the bottom of whose cylinder is 71 feet below the bottom of the pit. The piston rods extend upward through the well to the crank disks on the engine-room floor. At a distance of 70 feet from this pit another is sunk below the water line, connected to the main well by a tunnel, and fed by a 10-inch well sunk in its bottom. It was in this pit that the water level was observed during the test.

The results of the test are given in the following table:

*Test of plant No. 8, the Hermosa plant, May 21, 1904.*

Time.	Revolutions per minute.		Discharge head.	Float reading.		Total head.	Gallons per minute.	Hydraulic horse-power.	Mean effective pressure, No. 120 spring.	Explosions per minute.	Indicated horse-power.
	Engine	Pump.		Feet.	Ft. In.						
10.40.....	258	35	90	55 4	145.6	398	.....	69.2	.....	129	.....
11.00.....	255	34	90	56 0	146.2	373	.....	65.8	.....	127.5	.....
11.20.....	265	35	90	56 10	147	390	.....	66.1	.....	132.5	.....
11.40.....	270	36	90	57 2	147.4	381	.....	68.6	.....	135	.....
12.00.....	265	35	90	57 2	147.4	398	.....	71.5	.....	132.5	.....
12.20.....	272	36	90	57 2	147.4	398	.....	73.8	.....	136	.....
12.40.....	270	35	90	57 2	147.4	398	.....	65.3	.....	135	.....
1.00.....	268	35	90	57 2	147.4	348	.....	66.7	.....	134	.....
1.20.....	258	33	90	57 2	147.4	390	.....	68.5	.....	129	.....
1.40.....	263	35	90	57 5	147.6	398	.....	69.5	.....	131.5	.....
2.00.....	262	35	90	57 7	147.8	398	.....	70.4	.....	131	.....
2.20.....	267	35	90	57 9	148	398	.....	65.7	.....	133.5	.....
2.40.....	268	35	90	57 11	148.1	398	.....	68.1	.....	134	.....
3.00.....	267	35	90	58 0	148.2	398	.....	66.3	.....	133.5	.....
Average..	265	35	90	.....	147.35	390.3	14.59	68.25	.....	132.4	28.08

The combined efficiency of engine and pump is 51 per cent. The oil used was 48° distillate, costing 12 cents per gallon. The total oil used was 11.82 gallons in two hours forty minutes, or 4.43 gallons

per hour and 0.154 gallon per indicated horsepower per hour. At 12 cents per gallon the cost of fuel per hour is 53.2 cents. The useful work done in an hour is 3,470,000 foot-gallons, at a cost of 53.2 cents. Hence the cost per 1,000,000 foot-gallons is 15.3 cents; the oil used per 1,000,000 foot-gallons, 1.28 gallons; the cost per foot-acre-foot, 4.97 cents, and the oil per foot-acre-foot, 0.42 gallon.

*Plant No. 9.*—This plant, owned by the Chase Nursery, Corona, Riverside County, Cal., consists of a 75-horsepower gasoline engine and a triplex plunger pump (fig. 13). The engine cylinders, 3 in number, measure 11 by 12 inches; the speed is 290 revolutions per minute.

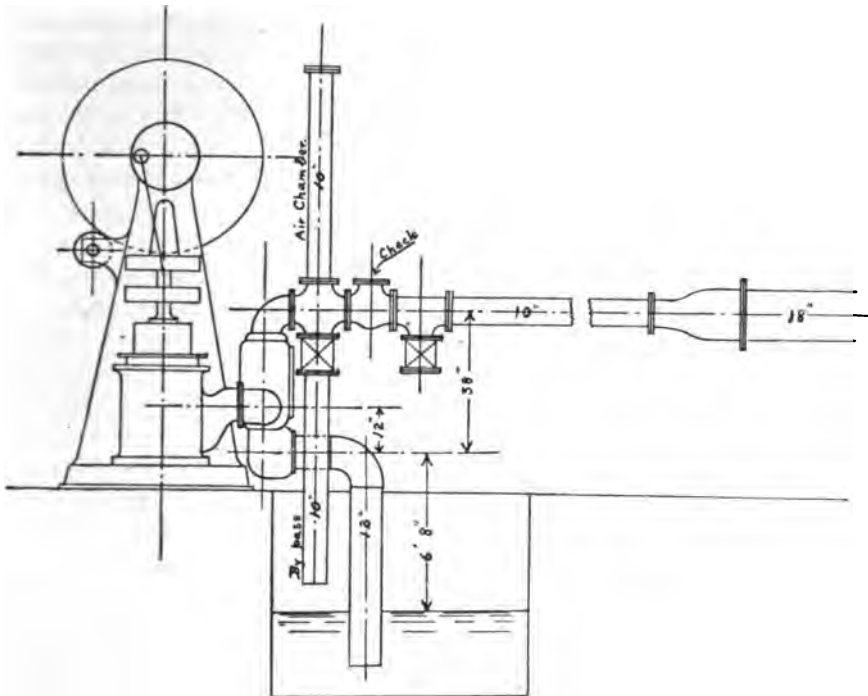

FIG. 13.—Plan of pumping plant at Chase Nursery, Corona, Cal.

The engine is direct connected to the pump and is fitted with a retort. The pump cylinders, 3 in number, are 14 by 12 inches; the suction pipe, 12 inches in diameter with 1 elbow; discharge pipe, 10 inches at pump, with 1 elbow and check valve, enlarging to 18 inches outside the pump house. The water is measured over a 25-inch rectangular weir at the upper point (No. 3), and a 36-inch rectangular weir at lower point (No. 2). The weirs were already in place and were used with small alterations. The total mean lift to point No. 3 is 195 feet (measured); the total mean lift to point No. 2, 133 feet (measured). In this plant the water is drawn from a canal under a low head and forced directly into a main 4,210 feet in length. The

first section nearest to the pump is 18 inches in diameter, 1,660 feet in length, and is carried to a point 80 feet above the pump, where outlet No. 1 is taken off. Above this is 1,215 feet of 16-inch pipe to outlet No. 2, 133 feet above the pump, and the last section, consisting of 1,356 feet of 14-inch pipe, reaching an elevation of 200 feet at outlet No. 3.

The engine could not be satisfactorily indicated, owing to the excessive vibrations of the pencil on the drum of the indicator. The indicated horsepower and combined efficiency are therefore not given. The pump is of the ordinary geared triplex type, with a check valve in the discharge. In starting, a by-pass is opened, and this is closed when the engine is up to speed. The gearing between the engine and pump has a ratio of about 1 to 7.3. The displacement of the pump, 946 gallons per minute, does not agree well with the measured discharge, 868 gallons per minute, for there is seldom so great a difference in pumps of this class. No investigation was made as to the cause of this discrepancy.

Two tests were made on this plant—one with the water discharging at No. 3 and another (incomplete) at No. 2. The results, with the water discharging at point No. 3, are given in the following table:

*Test of plant No. 9, Chase Nursery Company, at point No. 3, June 19, 1904.*

Time.	Revolutions per minute.		Discharge head.	Suction head.	Total head.	Gallons per minute.
	Engine.	Pump.				
			<i>Feet.</i>	<i>Feet.</i>	<i>Feet.</i>	
2.45 .....	285	391	187	5.7	192.7	.....
3.15 .....	285	391	187	5.7	192.7	.....
3.40 .....	285	391	187	5.7	192.7	.....
4.00 .....	285	391	187	5.7	192.7	.....
4.20 .....	285	391	187	5.7	192.7	.....
4.40 .....	290	391	187	5.7	192.7	.....
4.55 .....	297	391	187	5.7	192.7	.....
5.00 .....	298	391	187	5.7	192.7	.....
Average .....	289	391	187	5.7	192.7	868

The oil used was 44° engine distillate, costing 9.5 cents per gallon; density, 0.80. The total oil used was 119.5 pounds in two hours ten minutes; 17.92 gallons in two hours ten minutes, or 8.27 gallons per hour, costing therefore 78.5 cents per hour for fuel. The useful work was 10,050,000 foot-gallons in an hour. Hence the cost per 1,000,000 foot-gallons was 7.81 cents; oil per 1,000,000 foot-gallons, 0.814 gallon; cost per foot-acre-foot, 2.5 cents, and oil per foot-acre-foot, 0.26 gallon. If oil costing 12 cents per gallon were used, and assuming that the efficiency remained the same, we would have: Cost per 1,000,000 foot-gallons, 9.8 cents, and cost per foot-acre-foot, 3.18 cents. But if Coalinga oil at 5 cents be substituted—and the makers of the engine claim it will work as well or better with this fuel—the cost falls to: Cost per 1,000,000 foot-gallons, 4.1 cents; cost per foot-

acre-foot, 1.33 cents. These results of course can not be vouched for without actual tests and are merely mentioned as possibilities.

The test with the discharge at point No. 2 gives merely a few measurements on head and quantity, for because of an unfortunate accident it was not possible to measure the oil. The results are as follows:

*Test of plant No. 9, Chase Nursery Company, at point No. 2, June 20, 1904.*

Time.	Revolutions per minute.		Discharge head.	Suction head.	Total head.	Gallons per minute.	Hydraulic horsepower.
	Engine.	Pump.					
8.45 .....	301	40	<i>Feet.</i> 127	<i>Feet.</i> 5.7	<i>Feet.</i> 132.7	.....	.....
9.00 .....	301	40	127	5.7	.....	.....	.....
9.20 .....	286	40	127	5.7	.....	.....	.....
9.40 .....	285	40	127	5.7	.....	.....	.....
9.50 .....	288	40	127	5.7	.....	.....	.....
10.00 .....	290	40	127	5.7	.....	.....	.....
10.20 .....	302	40	127	5.7	.....	.....	.....
10.40 .....	302	40	127	5.7	.....	.....	.....
11.00 .....	300	40	127	5.7	.....	.....	.....
Average .....	295	40	127	5.7	132.7	868	29.2

The results obtained for this plant are by far the best of any of the gasoline engine plants tested. The low cost of operation appears to be due to the highly efficient pump, the direct connection of the engine to the pump, the highly efficient pipe line, and the low cost of fuel. To this must be added the comparatively large size of the unit.

#### PLANTS USING ELECTRIC MOTORS.

*Plant No. 10.*—This plant, owned by the Sunnyside Water Company, near Portersville, in the San Joaquin Valley, consists of a 50-horsepower induction motor, 7,200 alternations, 2-phase, 2,000 volts, 830 revolutions per minute, and a No. 4 compound horizontal centrifugal pump. The inlet and outlet openings are 4 inches in diameter; the discharge pipe, 13 feet of 6-inch casing, to 90° elbow, enlarging to 10-inch at main discharge. Redwood pipe in main line. There are three suction pipes, 6 inches in diameter in 10-inch wells, 140 to 150 feet deep. The pump is direct connected to motor (fig. 14). The water is measured over an 18-inch Cipolletti weir at upper point (No. 2) and 15-inch rectangular weir at lower point (No. 1). These weirs were already in place.

The static heads above pump are, at point No. 2, 123 feet (measured), and at point No. 1, 94 feet (measured); the static head below pump 27 feet (estimated), and the total mean lift at point No. 2, 150 feet, at point No. 1, 121 feet. We have here a type of electric pumping plant widely used in the San Joaquin Valley. The pump and motor are directly connected, usually on one base, and are placed at the bottom of a comparatively shallow pit, from which the wells are sunk. The pit is curbed or lined with concrete. The power is usually obtained through

high pressure, long distance transmission lines, from water-operated plants in the foothills of the Sierra Nevada Mountains. In this locality power is sold at a flat rate of \$50 per horsepower per year, whether the plant is running or not. This rating is based upon the measured horsepower delivered to the motor when first installed, and not upon the nominal horsepower of the motor. This measurement is checked up occasionally by the power company. When power is obtained

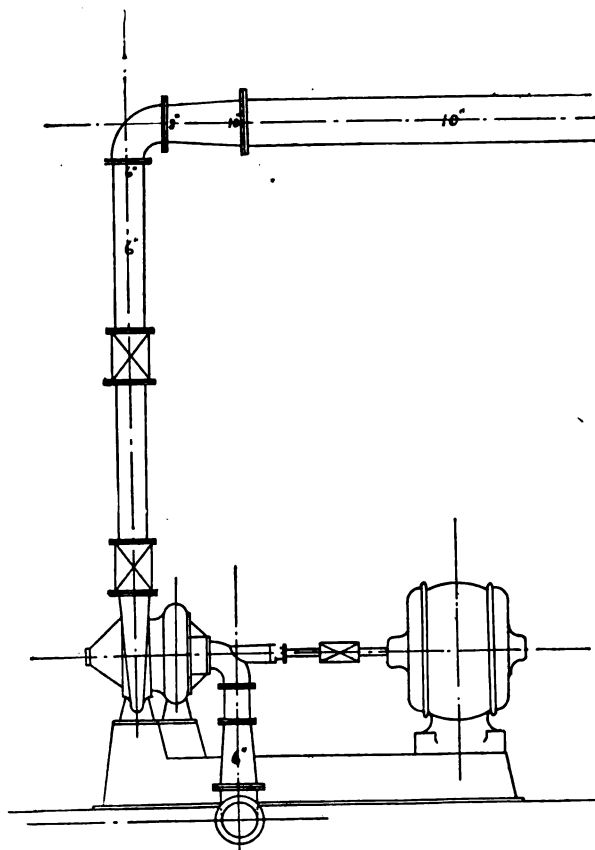

FIG. 14.—Plan of pumping plant owned by Sunnyside Water Company, Portersville, Cal.

under these conditions there is no common ground upon which to base a comparison between the running cost of motor and gas-engine driven plants, unless the actual number of hours of running during the year are known. Fairly exact figures have been obtained from some of the plants on this latter point, and tend to show that the run varies from about two thousand five hundred hours in small private plants to five thousand hours in larger plants owned by water companies. It is probably best to rate the cost of raising 1,000,000 foot-gallons, not in

dollars and cents, but in kilowatt hours, since this latter unit has a different price in each locality.

Two tests were made on this plant—one with the water discharging at point No. 2, and another at point No. 1. The results are as follows:

*Test of plant No. 10, Sunnyside Water Company, at point No. 2, May 18, 1904.*

Time.	Revolutions per minute of pump.	Discharge head.	Suction head.	Total head.	Gallons per minute.	Hydraulic horsepower.	Kilowatts.		Electrical horsepower.
							Meter A.	Meter B.	
		<i>Feet.</i>	<i>Feet.</i>	<i>Feet.</i>					
3.30 .....	868	125. 8	27. 8	153. 6	388	16. 1	14. 5	13	36. 9
3.45 .....	875	125. 3	27. 9	153. 2	388	15. 2	13	12. 5	34. 2
4.00 .....	875	125. 3	28. 3	153. 6	388	14. 3	13. 5	14	36. 9
4.15 .....	875	125. 3	28. 3	153. 6	388	15. 3	18. 75	13	35. 7
4.30 .....	877	125. 3	28. 5	153. 8	388	15. 4	14	13	36. 2
4.45 .....	974	125. 3	28. 3	153. 6	388	15. 8	13. 75	12. 75	35. 5
5.00 .....	875	125. 3	28. 3	153. 6	388	14. 8	13. 75	12. 5	35. 2
5.15 .....	868	125. 3	27. 8	153. 1	388	14. 7	13. 75	12. 5	35. 2
5.30 .....	876	125. 3	28. 3	153. 6	388	14. 8	13. 75	12. 5	35. 2
5.45 .....	876	125. 3	28. 3	153. 6	388	14. 8	13. 75	12. 5	35. 2
6.00 .....	875	125. 3	28. 3	153. 6	388	14. 8	13. 75	12. 75	35. 5
Average ..	874	125. 3	28. 2	153. 5	388	15. 11	26. 57		35. 61

The combined efficiency of motor and pump is 42 per cent. The mean power used during the test was 26.57 kilowatts. The useful work in an hour was 3,500,000 foot-gallons; hence, the kilowatt hours per 1,000,000 foot-gallons were 7.59, and kilowatt hours per foot-acre-foot, 2.46. It is not known on what horsepower rating the price of power is paid, but assuming it to be the electrical horsepower measured on the test, and that the time of pumping is five thousand hours per year, we can arrive at a rough estimate of what it is costing to pump water here. Fifty dollars per horsepower per year means \$67 per kilowatt per year, and taking five thousand working hours in the year, we see that the cost of a kilowatt hour on this basis is 1.34 cents; hence, cost per 1,000,000 foot-gallons = 10.2 cents; cost per foot-acre-foot = 3.31 cents. If the hours of running are only 2,500, the above figures will be doubled.

The results of the test with the water discharged at point No. 1 are as follows:

*Test of plant No. 10, Sunnyside Water Company, at point No. 1, May 19, 1904.*

Time.	Revolutions per minute of pump.	Discharge head.	Suction head.	Total head.	Gallons per minute.	Hydraulic horsepower.	Kilowatts.		Electrical horsepower.
							Meter A.	Meter B.	
		<i>Feet.</i>	<i>Feet.</i>	<i>Feet.</i>					
11.10 .....	874	98. 1	29	127. 1	478	15. 3	13. 5	12. 5	34. 8
11.20 .....	876	98. 1	29. 5	127. 6	478	15. 4	13. 5	12. 5	34. 8
11.30 .....	876	98. 1	29. 5	127. 6	478	15. 4	14	13	36. 2
11.45 .....	876	98. 1	29. 5	127. 6	478	15. 4	13	12. 3	33. 9
11.50 .....	875	98. 1	29. 5	127. 6	478	15. 4	13. 25	12. 25	34. 2
12.00 .....	872	98. 1	29. 5	127. 6	478	15. 4	13. 75	12	34. 6
12.10 .....	875	98. 1	29. 6	127. 7	478	15. 5	13. 25	11. 75	33. 6
12.20 .....	872	98. 1	29. 6	127. 7	478	15. 5	13. 5	12	34. 2
12.30 .....	873	98. 1	29. 6	127. 7	478	15. 6	13. 75	11. 75	34. 2
Average ..	874	98. 1	29. 5	127. 6	478	15. 4	25. 72		34. 5

The combined efficiency of motor and pump is 45 per cent. The mean power used for the test was 25.72 kilowatts, and the useful work done in an hour is 3,470,000 foot-gallons; hence, kilowatt hours per 1,000,000 foot-gallons, 7.41; and the kilowatt hours per foot-acre-foot, 2.4. Taking the year's run at five thousand hours we have: Cost per 1,000,000 foot-gallons, 9.9 cents, and cost per foot-acre-foot, 3.2 cents.

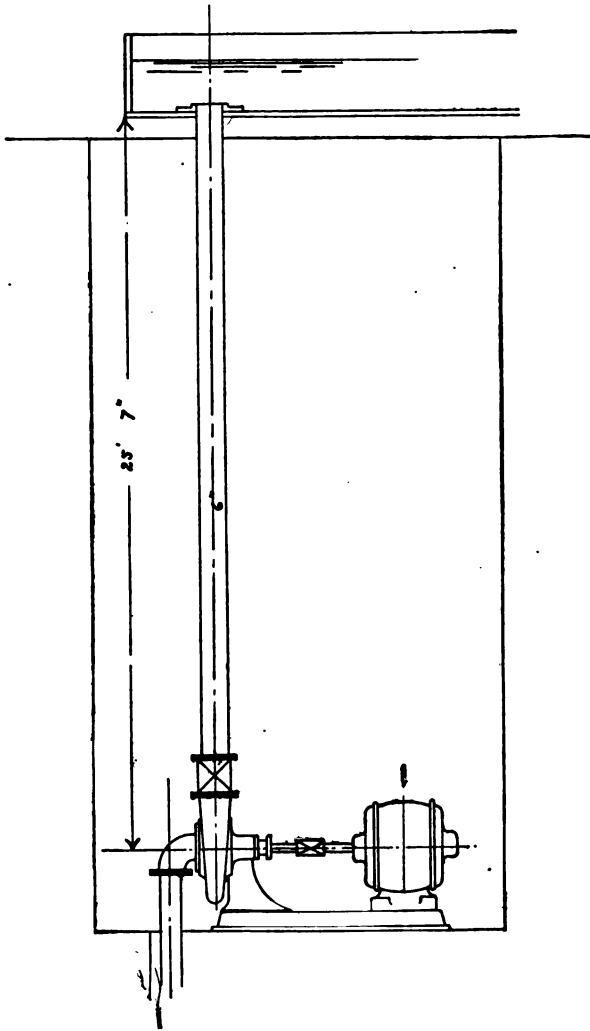

FIG. 15.—Plan of pumping plant owned by Mr. Hall, Lindsay, Cal.

*Plant No. 11.*—This plant, owned by Mr. Hall, Caledonian Colony, Lindsay, San Joaquin Valley, Cal., consists of a 10-horsepower induction motor, 7,200 alternations, 2-phase, 200 volts, 1,120 revolutions per minute, and a No. 4 single-runner horizontal centrifugal pump, with inlet and outlet pipes 4 inches in diameter; discharge pipe 6

inches in diameter, with a straight rise to box. There is one suction pipe, 6 inches in diameter, and one check valve. The pump is direct-connected to motor (fig. 15). The water is measured over a 24-inch Cipolletti weir, put in for test and left in place. The static head above pump is 26 feet (measured), the static head below pump 13 feet 2 inches (measured), the total lift 39 feet 2 inches. This plant is well arranged except for the check valve in the suction. The results of the test are given in the following table:

*Test of plant No. 11, Hall's Caledonian Colony, May 22, 1904.*

Time.	Revolutions per minute of pump.	Dis-charge head.	Suction head.	Total head.	Gallons per minute.	Hydrau-lic horse-power.	Kilowatts.		Electric-al horse-power.
							Meter A.	Meter B.	
		<i>Feet.</i>	<i>Feet.</i>	<i>Feet.</i>					
4.30 .....	1,188	26	20.2	46.2	.....	.....	3.85	2.95	9.1
4.45 .....	1,180	26	20.4	46.4	.....	.....	3.83	2.95	9.1
5.00 .....	1,195	26	20.4	46.4	.....	.....	3.85	3	9.2
5.15 .....	1,190	26	20.4	46.4	.....	.....	3.85	3	9.2
5.30 .....	1,190	26	20.6	46.6	.....	.....	3.85	3	9.2
5.45 .....	1,188	26	20.8	46.8	.....	.....	3.80	3	9.1
6.00 .....	1,189	26	20.8	46.8	.....	.....	3.80	2.95	9
Average ..	1,189	26	20.5	46.5	426	5.03	6.81		9.13

The combined efficiency of motor and pump is 55 per cent. The mean power used for the test was 6.81 kilowatts, and the useful work in an hour was 873,000 foot-gallons. Hence the cost is, kilowatt hours per 1,000,000 foot-gallons, 7.8; and kilowatt hours per foot-acre-foot, 2.53. A plant of this sort would probably not run much over 3,000 hours in the year. On this basis a kilowatt hour would cost 2.23 cents when paid for at \$50 per horsepower per year, and we find: Cost per 1,000,000 foot-gallons, 17.4 cents; cost per foot-acre-foot, 5.64 cents. The performance of this plant is better than that of No. 10. It is well designed and gives an excellent efficiency.

*Plant No. 12.*—The plant owned by Miss Ruby Johnson, near Lindsay, San Joaquin Valley, consists of a 10-horsepower induction motor, 7,200 alternations, 2-phase, 200 volts, 1,120 revolutions per minute, and a No. 3 single-runner horizontal centrifugal pump, with inlet and outlet openings 3 inches in diameter. There is a straight lift to "tee" near flume. There are two suction pipes, 5-inch outside diameter casing, one direct from pump suction and the other connected by side outlet; one 6-inch and one 10-inch well. The pump is direct connected to motor. The water is measured over an 8-inch Cipolletti weir, already in place, and used for the test after small alterations. The static head above the pump is 53 feet (measured); the static head below the pump, 29 feet (measured); the total mean lift, 82 feet. The results of the test are as follows.



Test of plant No 12, owned by Miss Ruby Johnson, May 23, 1904.

Time.	Revolutions per minute of pump.	Discharge head.	Suction head.	Total head.	Gallons per minute.	Hydraulic horse-power.	Kilowatts.		Electric horse-power.
							Meter A.	Meter B.	
11.05	1,184	53.5	28.9	82.4	110		3.25	3.00	8.38
11.15	1,184	53.5	28.9	82.4	106		3.30	3.02	8.45
11.30	1,176	53.5	28.8	82.3	106		3.30	3.03	8.44
11.40	1,178	53.5	29.0	82.5	102		3.30	3.00	8.45
11.50	1,178	53.5	28.9	82.4	102		3.32	2.92	8.38
12.00	1,167	53.5	28.9	82.4	102		3.30	3.00	8.44
12.10	1,178	53.5	29.3	82.8	106		3.35	2.95	8.45
12.20	1,181	53.5	29.4	83.9	102		3.37	2.95	8.48
12.30	1,180	53.5	29.4	83.9	102		3.38	2.95	8.48
12.40	1,180	53.5	29.4	83.9	102		3.35	2.95	8.44
Average	1,172.6	53.5	29.1	82.87	104	2.18	6.30		8.44

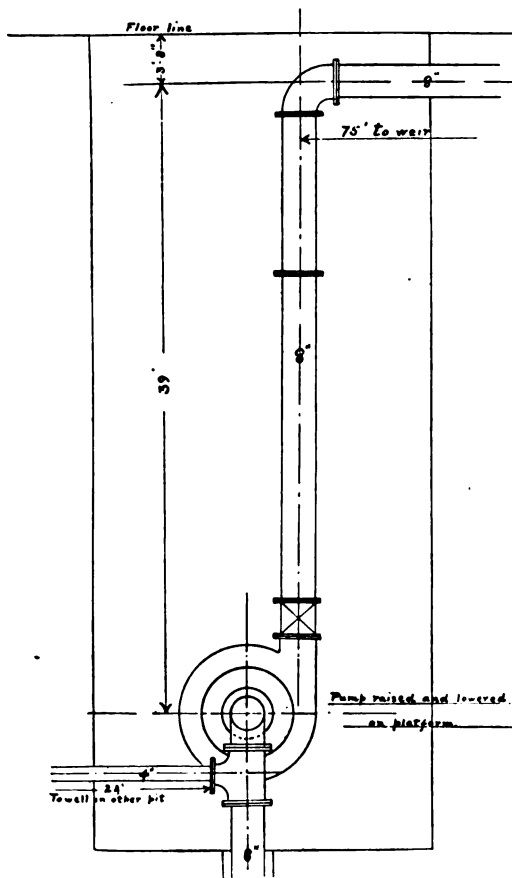

FIG. 16.—Plan of pumping plant owned by Lindsay Water and Development Company.

The combined efficiency of motor and pump is 26 per cent. The mean power used for the test was 6.3 kilowatts, and the useful work done in an hour is 507,000 foot-gallons; the kilowatt hours per 1,000,000 foot-gallons, 12.4; and kilowatt hours per foot-acre-foot, 4.03. In this plant the suction lift is altogether too high. When so high as this a vacuum may form in the runner which causes an immediate falling off in efficiency. Laboratory tests have shown that this vacuum may form long before a gauge connected to the suction elbow shows a vacuum. High suction head also induces leakage of air at the stuffing box. It appears also that the pump is running below speed, 1,210 revolutions per minute being much more

nearly the proper speed. In such direct connected pumps this can not be altered. A pump as small as this can not be expected in any case to give an efficiency comparable with 5-inch and 6-inch pumps.

*Plant No. 13.*—This plant is owned by the Lindsay Water and Development Company, near Lindsay, in the San Joaquin Valley (fig. 16). It consists of a 50-horsepower induction motor, 2-phase, 2,000 volts, 830 revolutions per minute—7,200 alternations; and a No. 6 single-runner horizontal centrifugal pump, with inlet and outlet openings 6 inches in diameter; discharge pipe 8 inches in diameter, with one elbow to ditch and three elbows to weir box. Diffuser on end of discharge line. There are two suction pipes, one 8 inches in diameter directly from well to suction elbow, and one 4 inches in diameter entering by side outlet from well 24 feet away. The pump is direct connected to motor. The water is measured over a 26-inch Cipolletti weir, already in place at time of test. The static head above the pump is 44 feet 6 inches (measured); the static head below pump, 19 feet (estimated); the total mean lift, 63 feet 6 inches. The results of this test can not be given full credit, as it was afterwards discovered that an elbow or some sort of fitting was attached to the inside end of the pipe to which the pressure gauge was attached. This fitting was directed downward so as to receive the impact of the discharging stream, and therefore caused the pressure gauge to read slightly too high by an amount not greater than the velocity head. It was not possible to remove this without taking down the discharge pipe. However, as the velocity head did not amount to more than 2.5 feet, and as the effect upon the gauge was probably less than this amount, the efficiency test is inserted. The effect of the elbow would be to increase the apparent efficiency of the pump as based on gauge readings, but to lower the actual efficiency of the plant by obstructing the flow. The pump was so arranged as to be raised and lowered on a cage within the pit. Sections of the suction and discharge pipes could be removed or inserted to allow for this change. This is an excellent plan when the level of the ground water is known to change.

Two tests were made on this plant, one with the pump partly throttled by a gate valve in the discharge and the other full open. It is understood that the first of these two corresponds with the ordinary running conditions. The practice of running a pump throttled can not be other than a wasteful one.

The results of the first test are as follows:

*Test of plant No. 13, Lindsay Water and Development Company, pump throttled, May 24, 1904.*

Time.	Revolutions per minute of pump.	Discharge head.	Suction head.	Total head.	Gallons per minute.	Hydraulic horsepower.	Kilowatts.		Electrical horsepower.
							Meter A.	Meter B.	
		<i>Feet.</i>	<i>Feet.</i>	<i>Feet.</i>					
10.00.....	863	74.1	19.6	93.7	752		7.75	12.75	27.3
10.05.....	863	73.8	19.8	93.7	750		7.50	13	27.5
10.10.....	864	73.5	19.9	93.5	750		7.50	13	27.5
10.15.....	864	73.5	20.3	93.8	767		7.50	13	27.5
10.20.....	864	73.5	20.4	93.9	767		7.50	13	27.5
10.25.....	864	72.7	20.6	93.3	767		7.50	13	27.5
10.30.....	864	72.7	20.6	93.3	767		7.50	13	27.5
10.35.....	864	72.7	20.6	93.3	767		7.52	13.20	27.8
10.40.....	864	72.7	20.6	93.3	767		7.52	13.20	27.8
10.45.....	864	72.4	20.8	93.2	767		7.52	13	27.5
10.50.....	864	72.4	21	93.4	767		7.30	13	27.2
10.55.....	864	72.5	21.1	93.6	767		7.75	13	27.8
11.00.....	864	72.5	21.1	93.6	767		7.75	13	27.8
11.05.....	864	72.4	21	93.4	767		7.80	13	27.9
Average..	864	72.9	20.5	93.5	762.1	18.08	20.58		27.58

The combined efficiency of motor and pump is 65 per cent. The mean power used for the test was 20.58 kilowatts, and the useful work done in an hour is 2,910,000 foot-gallons. Hence, kilowatt hours per 1,000,000 foot-gallons, 7.1; kilowatt hours per foot-acre-foot, 2.3. If, however, the pump had been working on a bona fide head of about 90 feet as shown by the gauges, instead of wasting 28 feet by throttling, we should have had 4,130,000 foot-gallons of work in an hour, and the expenditure would have been only 5 kilowatt hours per 1,000,000 foot-gallons, and 1.62 kilowatt hours per foot-acre-foot. The time during which this plant is operated averages for the past three years almost exactly five thousand hours per year. It is not known upon what horsepower rating the charge of \$50 per year is based, but assuming it to be the same as given in the test, the cost of operating the pump in its throttled condition is 9.5 cents per 1,000,000 foot-gallons, or 3.08 cents per foot-acre-foot.

The results of the second test are as follows:

*Test of plant No. 13, Lindsay Water and Development Company, pump full open, May 24, 1904.*

Time.	Revolutions per minute of pump.	Discharge head.	Suction head.	Total head.	Gallons per minute.	Hydraulic horsepower.	Kilowatts.		Electrical horsepower.
							Meter A.	Meter B.	
		<i>Feet.</i>	<i>Feet.</i>	<i>Feet.</i>					
11.35.....	861	43.6	27.1	70.7	1,123		10	15.5	34.2
11.40.....	864	43.6	27.2	70.8	1,123		9.5	15.5	33.5
Average..	864	43.6	27.15	70.75	1,123	20.15	25.25		33.85

The combined efficiency of motor and pump is 62 per cent. The mean power used for the test was 25.25 kilowatts, and the useful work

done in an hour 4,300,000 foot-gallons. Hence, the kilowatt hours per 1,000,000 foot-gallons, 5.87; the kilowatt hours per foot-acre-foot, 1.9; and at five thousand hours' run per year the cost per 1,000,000 foot-gallons is 7.9 cents; the cost per foot-acre-foot, 2.56 cents. Nothing could show more clearly the evils of throttling a pump. The plant otherwise gives a remarkably high efficiency.

*Plant No. 14.*—The plant owned by Norcross & Crane, Lindsay, Cal., in the San Joaquin Valley, consists of a 7.5-horsepower induction motor, 2-phase, 200 volts, 7,200 alternations, 1,120 revolutions per minute, and a No. 3 single-runner horizontal centrifugal pump, with inlet and outlet openings 3 inches in diameter; discharge pipe 6 inches in diameter throughout; one 3-inch check valve and taper connections. It has direct discharge into box without elbows, and no diffuser. There is one suction pipe 6 inches in diameter, 40 feet long; pit 8 feet square, 31 feet deep. The pump is direct connected to motor. A 16-inch Cipolletti weir was used. The static head above pump is 30 feet 6 inches (measured); the static head below the pump, 11 feet (estimated); total mean lift, 41 feet 6 inches. The results of the test are as follows:

*Test of plant No. 14, owned by Norcross & Crane, May 25, 1904.*

Time.	Revolutions per minute of pump.	Discharge head.	Suction head.	Total head.	Gallons per minute.	Hydraulic horse-power.	Kilowatts.		Electrical horse-power.
							Meter A.	Meter B.	
		<i>Feet.</i>	<i>Feet.</i>	<i>Feet.</i>					
2.45.....	1,170	31.1	13.4	44.4	252	.....	2.15	2.475	6.71
2.55.....	1,170	31.1	13.3	44.3	252	.....	2.16	2.50	6.23
3.00.....	1,175	31.1	13.3	44.3	252	.....	2.15	2.50	6.23
3.10.....	1,170	31.1	13.3	44.3	252	.....	2.20	2.52	6.33
3.20.....	1,172	31.3	13.4	44.7	252	.....	2.15	2.52	6.27
3.30.....	1,165	31.3	13.2	44.3	252	.....	2.15	2.55	6.30
3.40.....	1,165	31.3	13.2	44.3	252	.....	2.15	2.50	6.23
3.50.....	1,165	31.3	13.3	44.6	252	.....	2.17	2.525	6.29
4.00.....	1,165	31.3	13.3	44.6	252	.....	2.125	2.525	6.29
4.10.....	1,165	31.3	13.4	44.7	252	.....	2.125	2.525	6.29
4.20.....	1,165	31.3	13.5	44.8	252	.....	2.13	2.525	6.24
Average...	1,168	31.2	13.3	44.48	252	2.84	4.67		6.314

The combined efficiency of motor and pump is 45 per cent. The mean power used for test was 4.67 kilowatts, and the useful work, 627,500 foot-gallons per hour; therefore, the kilowatt hours per 1,000,000 foot-gallons were 7.4, and the kilowatt hours per foot-acre-foot, 2.42. The number of hours run in a year is about two thousand six hundred in this plant, hence the cost of a kilowatt hour is 2.58 cents, the cost per 1,000,000 foot-gallons is 19.2 cents, and the cost per foot-acre-foot 6.26 cents. The arrangement of machinery is here good, though a diffuser on the discharge might have helped. The results are fair, but show clearly the lower efficiency of the smaller pump, other things being equal.

*Plant No. 15.*—The plant at the Peyton station of the Temescal Water Company, Ethenac, Riverside County, Cal., consists of a 40-horsepower induction motor, 50 cycles, 3-phase, 220 volts, 750 revolutions per minute; diameter of pulley, 16 inches; 12-inch belt, and a triplex plunger pump, with three plungers 14 inches in diameter; 15-inch stroke; pulley 50 inches in diameter; discharge pipe 12 inches in diameter, one elbow and one check valve; three suction—one 7-inch suction to well No. 1, one 10-inch suction with 8-inch side outlet to well No. 2, one 8-inch continuation to well No. 3 (see fig. 17). The

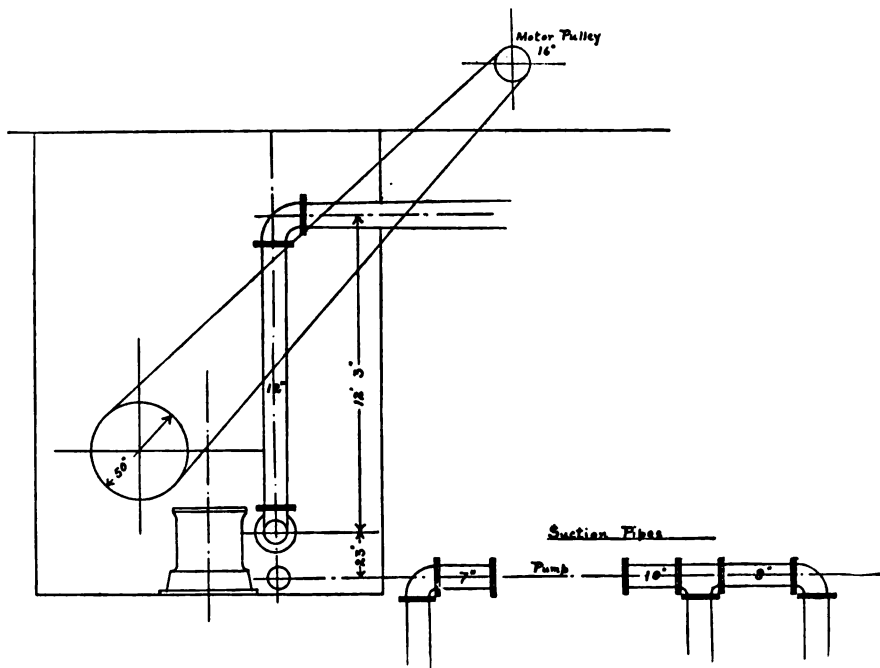

FIG. 17.—Plan of Peyton pumping plant belonging to Temescal Water Company.

pump is belted direct to motor. A 50-inch rectangular weir, with steep edges, was already in place at time of test. The static head above pump is 14 feet (measured); the static head below pump, 22 feet (measured); the total lift, 36 feet. Here we have a plant similar to that at Corona (Plant No. 9), but with a low lift. The measured discharge, 1,232 gallons per minute, does not check with the pump displacement, 1,495 gallons per minute. The results of this test are given in the table following.

Test of plant No. 15, Temescal Water Company, Peyton station.

Time.	Revolutions per minute of pump.	Discharge head.	Suction head.	Total head.	Gallons per minute.	Hydraulic horse-power.	Kilowatts.		Electrical horse-power.
							Meter A.	Meter B.	
		<i>Feet.</i>	<i>Feet.</i>	<i>Feet.</i>					
8.45.....	50	22.4	23.8	46.2	.....	.....	3.80	14.2	24.1
8.55.....	50	22.4	23.8	46.2	.....	.....	3.80	14	23.9
9.00.....	50	22.4	23.8	46.2	.....	.....	3.70	13.9	23.6
9.10.....	50	22.4	23.8	46.2	.....	.....	3.70	13.8	23.5
9.20.....	50	22.4	24	46.4	.....	.....	3.70	13.7	23.3
9.30.....	50	22.4	24	46.4	.....	.....	3.70	13.7	23.3
<b>Average..</b>	50	22.4	23.9	46.27	1,232	14.4	17.62		23.61

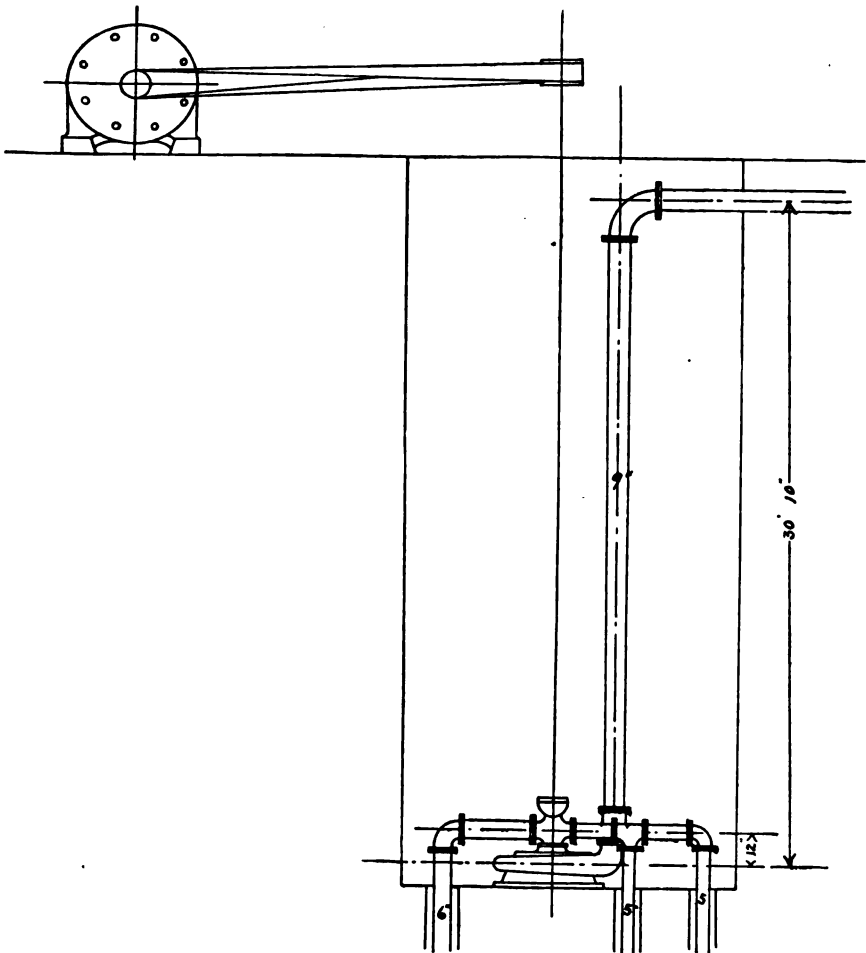

FIG. 18.—Plan of pumping plant E, belonging to Temescal Water Company.

The combined efficiency of motor and pump is 60.9 per cent. The mean power used for the test was 17.62 kilowatts; the useful work done, 2,661,000 foot-gallons per hour; therefore the kilowatt hours

per 1,000,000 foot-gallons were 6.63; the kilowatt hours per foot-acre-foot, 2.15. The results of this test show that the triplex plunger pumps, even when designed for the purpose, do not work at their best on heads so low as this. The same is borne out by the laboratory tests on small pumps of this type. The installation is, nevertheless, a most excellent one. All the plants of the Temescal Water Company are supplied with electric power from a central station owned by the company. It is understood that the cost to the company for fuel alone is not above 1 cent per kilowatt hour. To this of course must be added the cost of labor; taxes, and depreciation of plant, etc., which will probably raise the cost to 2.25 cents. On this supposition the figures become: Cost per 1,000,000 foot-gallons, 15.15 cents; cost per foot-acre-foot, 4.91 cents.

*Plant No. 16.*—The equipment at station E of the Temescal Water Company, Ethenac, Riverside County, Cal., consists of a 20-horse-power induction motor, 6,000 alternations, 3-phase, 200 volts, 930 revolutions per minute; pulley, 11 inches in diameter; 8-inch belt; and a No. 5 single-runner vertical centrifugal pump, with inlet and outlet openings 5 inches in diameter; discharge pipe 9 inches to elbow, then 12 inches to canal; one 6-inch check valve and taper connection; three suction pipes; one 6-inch suction, 5-inch side outlet to well No. 1; one 5-inch continuation to well No. 2; one 6-inch pipe to well No. 3; pulley, 18 inches in diameter (fig. 18). A 20-inch rectangular weir was already in place. The static head above the pump is 31 feet (measured); the static head below the pump, 22 feet (estimated); the total mean lift, 53 feet. In this station we have a vertical centrifugal pump belted to a motor. The results of the test are as follows:

*Test of plant No. 16, Temescal Water Company, Station E, June 16, 1904.*

Time.	Revolutions per minute of pump.	Discharge head.	Suction head.	Total head.	Gallons per minute.	Hydraulic horse-power.	Kilowatts.		Electric horsepower.
							Meter A	Meter B.	
		<i>Feet.</i>	<i>Feet.</i>	<i>Feet.</i>					
11.00.....	600	33.6	23.2	56.9			10.8	5.05	21.25
11.10.....	600	33.6	22.7	56.3			10.7	5	21.05
11.20.....	585	34.8	22.7	57.5			10.7	5	21.05
11.30.....	595	34.8	22.7	57.5			11	5	21.45
11.40.....	595	34.8	22.8	57.6			11	5	21.45
11.45.....	586	34.8	22.9	57.7			11	5	21.45
11.50.....	586	34.8	22.9	57.7			11	5	21.45
12.00.....	586	34.8	23	57.8			11	5	21.45
Average..	592	34.5	22.9	57.4	544	7.92	15.91		21.32

The combined efficiency of motor and pump is 37 per cent. The mean power used for the test was 15.91 kilowatts, the useful work per hour, 1,730,000 foot-gallons; hence, kilowatt hours per 1,000,000 foot-gallons, 9.19; kilowatt hours per foot-acre-foot, 2.98. The low efficiency of this pump appears to be due to the fact that it is running under speed for the particular head existing at the time of the test. Accord-

ing to the manufacturer's catalogue this pump should have run 670 revolutions per minute at 55-foot head.

The Temescal Water Company has four other pumping stations in the immediate vicinity, known as stations No. 1, No. 2, No. 4, and powerhouse station. An attempt was made to test No. 2 and No. 4, but it was found that the power was beyond the range of the wattmeters. Data, however, were obtained from the engineer in charge, on the performance of five of the stations, as read on their recording wattmeters and weir gauges. These are all centrifugal stations with 5-inch pumps, and 40-horsepower, 220-volt motors. The data furnished by the engineer are given in the following tables:

*Records of pumps of Temescal Water Company.*

APRIL 19-26, 1904.

Station.	Hours run.	Gallons per minute.	Head.	Watt hours.	Mean kilowatts.	Foot-gallons per hour.	Kilowatt hours per 1,000,000 foot-gallons.	Kilowatt hours per foot-acre-foot.
			<i>Feet.</i>					
Peyton.....	168	1,415	36	3,519,000	20.94	3,055,000	6.86	2.23
No. 2.....	168	1,415	50	6,333,000	37.70	4,243,000	8.88	2.88
No. 4.....	168	1,336	50	4,834,000	28.90	4,008,000	7.21	2.34

APRIL 26-MAY 3, 1904.

Peyton.....	168	1,415	36	3,465,000	20.62	3,055,000	6.75	2.19
No. 2.....	168	1,335	50	6,207,000	36.95	4,005,000	9.22	2.99
No. 4.....	168	1,292	50	4,698,000	27.90	3,875,000	7.20	2.34

MAY 5-10, 1904.

Peyton.....	168	1,390	36	3,360,000	20.00	3,003,000	6.66	2.16
No. 1.....	91	500	54	1,203,000	13.22	1,620,000	8.16	2.65
No. 2.....	168	1,265	50	6,147,000	36.60	3,795,000	9.64	3.13
No. 4.....	168	1,250	50	4,542,000	27.04	3,750,000	7.22	2.34
E.....	102	554	53	1,660,000	17.00	1,762,000	9.64	3.13

MAY 24-31, 1904.

Peyton.....	121	1,283	36	2,088,000	17.20	2,770,000	6.21	2.02
No. 1.....	168	483	54	1,860,000	11.07	1,565,000	7.08	2.20
No. 2.....	165	1,186	50	5,742,000	34.80	3,560,000	9.78	3.17
No. 4.....	155	1,210	50	4,239,000	27.3	3,630,000	7.52	2.44
E.....	134	483	53	2,196,000	16.40	1,536,000	10.66	3.46

NO DATE.

Peyton.....	168	1,390	36	3,356,000	20.00	3,003,000	6.66	2.16
No. 1.....	164	483	54	1,779,000	10.85	1,566,000	6.93	2.25
No. 2.....	168	1,230	50	5,793,000	34.50	3,690,000	7.20	2.34
E.....	168	510	53	2,481,000	14.78	1,623,000	9.11	2.96

AVERAGE.

Peyton.....							6.63	2.15
No. 1.....							7.39	2.40
No. 2.....							9.37	3.04
No. 4.....							7.28	2.36
E.....							9.80	3.18



Our own results on Peyton station are 6.63 kilowatt hours per 1,000,000 foot-gallons, and 2.15 kilowatt hours per foot-acre-foot; and on station E are 9.19 kilowatt hours per 1,000,000 foot-gallons, and 2.98 kilowatt hours per foot-acre-foot—a very fair agreement.

#### PLANTS USING STEAM ENGINES.

*Plant No. 17.*—The plant owned by O. F. Von Dorsten, near Campbell, in the Santa Clara Valley, consists of a 75-horsepower steam engine; a fire-tube boiler 54 inches in diameter, 16 feet long, pressure 95 pounds, oil pump 3 by 2 by 3 inches, with feed pump 4½ by 3 by 4 inches, feed-water heater; temperature of feed water, 180° F.; a No. 6 single-runner vertical centrifugal pump with inlet and outlet openings 6 inches in diameter; discharge pipe 9.5 inches in diameter to vertical standpipe 2.5 feet in diameter; pulley 18 inches in diameter; pump direct belted with quarter-turn belt; centers, 35 feet 9 inches. Balanced slide-valve engine, with cylinder 12 by 20 inches; speed, 150 revolutions per minute; pulley, 8 feet in diameter; belt, 12 inches. A 30-inch rectangular weir was used. The static head above pump at point No. 4 is 80 feet 6 inches (measured); static head below pump, 8 feet (measured); the total mean lift at point No. 4, 88 feet 6 inches. In this steam plant the general arrangement of engine and pump is quite similar to the gasoline plants, and requires no further description. The pump discharges into a tall standpipe, from which a pipe line conducts the water to various outlet points, No. 4 being the farthest removed and Nos. 3, 2, and 1 being successively nearer to the pump. There seems to be no possible use for the standpipe as an aid to conducting the water, but it was useful in the test itself as furnishing an actual measure of the lift. By this means the frictional resistances of a long pipe line are not charged against the plant in the calculation of its power value. Since the fuel test was made for point No. 4 alone, the measured lifts for the other points are of no particular value, but are inserted merely as a matter of interest: Total mean lift, point No. 3, 88 feet 6 inches; total mean lift, point No. 2, 82 feet 6 inches; total mean lift, point No. 1, 70 feet 6 inches. The results of the test are as follows.

Test of plant No. 17, owned by O. F. Von Dorsten (point No. 4), April 13, 1904.

Time.	Revolutions per minute.		Discharge head.	Suction head.	Total head.	Gallons per minute.	Hydraulic horsepower.	Boiler pressure.	Temperature of feed water.	Mean effective pressure, No. 40 spring.	Indicated horsepower.
	Engine.	Pump.									
11.15.....	152	793	86	10.8	99			95	188	52.8	46.2
11.35.....	150	800	86	10.8	96.8			95	185	56	48
11.55.....	151	802	84.6	11.3	96			97.4	175	59.8	51.6
12.30.....	151	798	86	11.3	97.3			90	175	54.4	46.9
1.00.....	151	800	84.6	11.3	96			95	175	52.8	45.6
1.30.....	151	802	84.6	11.7	96.3			95	190	53.3	46
2.00.....	151	800	84.6	11.9	96.5			100	180	51.4	44.3
2.30.....	151	800	86.9	12	98.9			97.4	184	51.4	44.3
3.00.....	151	800	86.9	11.5	98.4			90	170	54.3	46.8
3.30.....	151	800	86.9	12.2	99.2			95	176	54.9	47.4
Average.....	151	799.5	85.7	11.5	97.2	936	23.39	95	180	54.1	46.7

The combined efficiency of engine and pump at point No. 4 is 50 per cent; at point No. 3, 55 per cent; at point No. 2, 52 per cent; at point No. 1, 39 per cent. The oil used at point No. 4 was crude oil, 16.5° Baumé, costing 75 cents per barrel of 42 gallons; density, 0.975; total used for test, 853.9 pounds in 4.25 hours, 201 pounds per hour, or 24.7 gallons per hour, costing, therefore, 44.1 cents per hour for fuel. Water evaporated: Total for test, 10,473 pounds in 4.25 hours, or 2,418 pounds of water per hour; factor of evaporation, 1.0703; 2,588 pounds of water per hour from and at 212° F.; 12.86 pounds of water from and at 212° F. per pound of oil; 51.8 pounds of steam for all purposes per indicated horsepower of engine. The useful work done in an hour is 4,970,000 foot-gallons, at a cost of 44.1 cents; cost per 1,000,000 foot-gallons, 8.9 cents; oil per 1,000,000 foot-gallons, 4.97 gallons; cost per foot-acre-foot, 2.9 cents; oil per foot-acre-foot, 1.65 gallons.

This plant shows a higher efficiency and lower cost for fuel than most of the gasoline plants. The first seems to be due principally to the comparative large size of the unit; the second, to this and to the low cost of the fuel. It must be borne in mind, however, that a steam plant requires an engineer constantly in attendance, whose wages alone would make the cost of operation double the fuel cost in this case.

The results of tests at points 3, 2, and 1 are given in the following table:

*Test of plant No. 17.*

POINT NO. 3, APRIL 13, 1904.

Time.	Revolutions per minute.		Discharge head.	Suction head.	Total head.	Gallons per minute.	Hydraulic horsepower.	Mean effective pressure, No. 40 spring.	Indicated horsepower.
	En-gine.	Pump.							
5.00 .....	150	805	<i>Feet.</i> 79.8	<i>Feet.</i> 16.3	<i>Feet.</i> 96.1	1,093	.....	<i>Pounds.</i> 57.9	49.6
5.10 .....	150	806	79.8	16.6	96.3	1,093	.....	52.1	44.6
5.20 .....	150	804	78	16.2	96	1,093	.....	56.1	48.1
5.30 .....	150	804	78	16.1	94.1	1,093	.....	57.2	49
Average ..	150	804.5	78.9	16.3	95.6	1,093	26.51	55.8	47.8

POINT NO. 2, APRIL 14, 1904.

11.00 .....	152	802	73.5	14.6	88.2	1,054	.....	55.00	47.75
11.15 .....	150	800	73.5	14.6	88.2	1,093	.....	53.80	46.10
11.30 .....	150	800	73.5	14.2	87.7	1,054	.....	54.44	46.64
11.45 .....	151	805	73.5	14.2	87.7	1,093	.....	54.54	47.04
Average ..	151	802	73.5	14.4	87.9	1,073	23.93	54.44	46.88

POINT NO. 1, APRIL 14, 1904.

3.00 .....	150	800	70.8	11.0	81.8	941	.....	59.8	51.3
3.15 .....	150	800	70.8	11.4	82.2	941	.....	58.4	50.1
3.30 .....	150	800	70.8	11.9	82.7	941	.....	58	49.7
3.45 .....	150	800	70.8	12.1	82.9	941	.....	55.8	47.8
4.00 .....	150	801	70.8	12.2	83	941	.....	60.4	51.7
Average ..	150	800	70.8	11.7	82.52	941	19.7	58.5	50.1

*Plant No. 18.*—This plant, owned by H. Booksin, Willow Glen district, Santa Clara Valley, consists of a 75-horsepower Corliss steam engine; 44 inches by 14 feet return tubular boiler, and a No. 6 single-runner vertical centrifugal pump. The engine cylinder is 11.5 by 20 inches; speed, 115 revolutions per minute; belt, 12 inches. The boiler is 44 inches in diameter, 14 feet long, and has a feed-water heater; the temperature of feed water, 144° F. (average); boiler pressure, 95 pounds. The pump has inlet and outlet openings 6 inches in diameter; 32-inch runner; discharge pipe 12 inches throughout; one 6-inch check valve; taper connection; one long-radius elbow; suction pipes, 5 in number, in two pits. The pump is belted direct with quarter-turn belt, 27-foot centers. The water was measured over a 36-inch rectangular weir, placed in a portable weir box. The static head above the pump is 48 feet 3 inches (measured); the static head below the pump, 6 feet 6 inches (measured); the total mean lift, 54 feet 9 inches. In this plant the water discharges into a tank, from which it passes through a 12-inch main to the distributing system. The mean lift is measured to the level of the water in the tank, since the discharge is below the surface. The results of the test are as follows.

*Test of plant No. 18, owned by H. Booksin, April 24, 1904.*

Time.	Revolutions per minute.		Dis-charge head.	Suction head.	Total head.	Gallons per minute.	Hydrau-lic horse-power.	Mean effective pressure, No. 40 spring.	Indicated horse-power.
	Engine.	Pump.							
			<i>Feet.</i>	<i>Feet.</i>	<i>Feet.</i>			<i>Pounds.</i>	
12.00 .....	116	520	48.5	10.9	59.4	1,664	24.7	85.3	.....
12.30 .....	116	518	48.5	11.1	59.6	1,669	25	87	.....
1.00 .....	114	513	48.5	10.8	59.3	1,628	24.4	83.4	.....
1.30 .....	114	516	48.5	11	59.5	1,646	24.4	84.3	.....
2.00 .....	115	518	48.5	11.6	60.1	1,669	25.3	86.1	.....
2.30 .....	113	512	48.5	11.3	59.6	1,628	24.5	81.3	.....
3.00 .....	114	514	48.5	11.1	59.6	1,646	24.7	84.1	.....
3.30 .....	115	518	48.5	12.1	60.6	1,664	25.4	85.8	.....
4.00 .....	115	518	48.5	12.2	60.7	1,664	25.5	82.7	.....
4.30 .....	114	515	48.5	11.6	60.1	1,651	25	81.9	.....
Average..	114.6	516.2	48.5	11.4	59.85	1,653	25.09	84.2	50.61

The combined efficiency of engine and pump is 50 per cent. The oil used was crude oil, 16.6° Baumé, costing 75 cents per barrel of 42 gallons; density, 0.956; total used, 730 pounds in four hours and forty minutes, or 156 pounds of oil per hour; 19.6 gallons of oil per hour, costing 35 cents per hour for fuel. Total water evaporated for test, 5,889 pounds in three and one-half hours; 1,682 pounds per hour; factor of evaporation, 1.109; 1,865 pounds of water per hour from and at 212° F.; 11.93 pounds of water from and at 212° F. per pound of oil; 33.2 pounds of steam for all purposes per indicated horsepower of engine. The useful work done in an hour is 5,420,000 foot-gallons, at a cost of 35 cents; hence, cost per 1,000,000 foot-gallons, 6.46 cents; oil per 1,000,000 foot-gallons, 3.62 gallons; cost per foot-acre-foot, 2.1 cents; oil per foot-acre-foot, 1.17 gallons.

The exceptionally low fuel cost in this case is due to several causes. The first of these is the cheapness of the fuel, the second is the comparatively large size of the engine and pump, third the good arrangement of machinery, and fourth the type of engine. The first three of these are found in the preceding test (No. 18), but the fourth, which makes up the difference between the two, lies in the engine. An engine of this class uses steam more economically than a slide-valve engine. This shows at once in the steam consumption per indicated horsepower. Test No. 17 shows steam per indicated horsepower per hour, 51.8 pounds; test No. 18, steam per indicated horsepower per hour, 33.2 pounds. The boiler, however, is not working as well, as seen by the evaporation per pound of oil; test No. 17 shows water evaporated per pound of oil, 12.85; test No. 18 shows water evaporated per pound of oil, 11.93. Both these effects lie outside the combined efficiency.

*Plant No. 19.*—The plant owned by Floyd Lundy, Berryessa, Santa Clara Valley, consists of a 40-horsepower balanced slide-valve steam engine, a 40-horsepower return tubular boiler, and a No. 4 single-runner vertical centrifugal pump. The engine cylinder is 9 by 12

inches; speed, 250 revolutions per minute; pulley, 42 inches in diameter; belt, 10 inches. The boiler dimensions are not given; the feed pump is a 3 by 2 by 3 inch duplex; oil fed by gravity; feed-water heater; temperature feed water, 123° F.; boiler pressure, 100 pounds. The pump has inlet and outlet openings, 4 inches in diameter; discharge pipe, 10 inches throughout; one 4-inch check valve; taper connections; one long-radius elbow; two suction pipes, 5-inch casing; the pump is direct belted with quarter-turn belt to engine. A 24-inch Cipolletti weir, put in by our party, was used.

The static head above the pump is 62 feet 6 inches (measured); the static head below the pump, 8 feet 9 inches (measured); the total mean lift, 71 feet 3 inches. This pump had a bad upthrust, heating the lower collar box at the pump head. The results of the test are given in the following table:

*Test of plant No. 19, owned by Floyd Lundy, June 3, 1904.*

Time.	Revolutions per minute.		Dis-charge head.	Suction head.	Total head.	Gallons per minute.	Hy-draulic horse-power.	Mean effective pressure, No. 40 spring.	Indicated horse-power.
	Engine.	Pump.							
			Feet.	Feet.	Feet.			Pounds.	
1.30 .....	246	836	63.4	12.5	75.9	582	.....	57.5	27.3
2.00 .....	246	836	63.4	13.3	76.7	595	.....	58.1	27.6
2.30 .....	250	863	63.4	13.4	76.8	582	.....	56	27
3.00 .....	245	834	63.4	13.4	76.8	582	.....	56	26.5
3.20 .....	250	855	63.4	12.4	75.8	609	.....	56.6	26.8
3.40 .....	244	832	63.4	12.4	75.8	582	.....	55.6	26.1
4.00 .....	250	844	63.4	13.1	76.5	582	.....	55.2	26.6
4.20 .....	244	843	63.4	12.1	75.5	609	.....	54.9	25.8
4.40 .....	251	848	63.4	13.7	77.1	609	.....	56.2	27.2
5.00 .....	252	855	63.4	13.9	77.3	609	.....	55.4	26.9
5.20 .....	245	835	63.4	12.8	76.2	582	.....	55.6	25.8
5.40 .....	252	860	63.4	12.8	76.2	573	.....	56.7	27.5
Average .....	248	845	63.4	13.0	76.4	591	11.46	56.1	26.76

The combined efficiency of engine and pump is 43 per cent. The oil used was crude oil, 17° Baumé, costing 75 cents per barrel of 42 gallons; density, 0.954; total oil used in test, 58.9 gallons in four hours and ten minutes, 14.07 gallons per hour, costing 25.1 cents per hour for fuel. No test of water evaporated was made. The useful work done in an hour is 2,530,000 foot-gallons; hence, cost per 1,000,000 foot-gallons is 10 cents; oil per 1,000,000 foot-gallons, 5.56 gallons; cost per foot-acre-foot, 3.3 cents; oil per foot-acre-foot, 1.8 gallons. That this plant does not equal the performance of plant No. 17, where the same type of engine is used, appears to be due to the smaller unit. The performance is, however, very good.

#### LABORATORY TESTS.

The field tests which have just been described, though comparatively few in number, give a very fair idea of the combined efficiencies and fuel costs which now prevail in the average pumping plant in opera-

tion. How much of the variation therein is due to difference in arrangement of machinery, to neglect, to improper speed of pump, or to different types of pumps, is to be determined by a much more extensive investigation than the one completed in 1904. In regard to the two latter causes it may be of interest to present the results of tests made in the hydraulic laboratory of the University of California. These, of course, may not represent actual working conditions; in other words, they are made under the best possible conditions, but they are all made under exactly the same conditions, and therefore show most perfectly the effect of variation of speed or head on the efficiency of the pump, and the relative efficiencies of several different makes of pumps.

#### GENERAL DESCRIPTION OF LABORATORY.

The water supply of the laboratory is contained in a series of concrete-lined tanks sunk in the floor of the main court of the mechanical engineering building at Berkeley. One of these tanks, 19 by 19 feet in area and 12 feet deep, is used as a storage tank, and three others of the same depth, and ranging from 7 by 7 feet to 11 by 19 feet in area, are used as measuring tanks. In the main supply tank two 8-inch suction pipes are hung, each provided with a large foot valve. The pump to be tested is connected to one or the other, depending on whether the scroll is right or left handed. The discharge is passed through a gate valve and thence to a trough, which conducts it to the weir box. This is 16 feet long, 6 feet wide, and 2 feet deep. The water is passed through three baffle plates before reaching the weir. This latter is a 30-inch rectangular weir with sheet-iron edges, and the discharge can be either returned to the supply tank direct or can be turned into any one of the measuring tanks by a system of sliding gates made absolutely tight by rubber valves. The weir has been carefully rated by passing the water for a definite time into a measuring tank and noting the rise of the surface therein. These latter have been gauged by pouring in weighed quantities of water and noting the rise. For ordinary centrifugal pump tests the weir alone was used, the discharge being returned directly to the supply tank. For more careful tests regarding the effects of the diffuser and on triplex plunger pump tests, the measuring tank was used. The head was measured on two gauges inserted at right angles to the suction and discharge pipes, credit for the difference in level between the gauges being also allowed the pump. These gauges are carefully compared with a mercury column and with a standard-weight gauge tester before each test.

The mechanical power applied to the pump is measured on a 20-horsepower transmission dynamometer, which in its turn receives its power from a 15-horsepower direct-current electric motor. The speed

of the pump is taken at intervals on an ordinary revolution counter, and is also shown on a high-grade tachometer. This latter is used principally to detect variations in speed, which can be checked at once and the speed held absolutely constant by a rheostat in the field of the motor. In order to get a wide range of speeds for different tests a series of ten pulleys from 4 inches to 16 inches in diameter are used on the motor.

In making a test the pump is placed in position and connected to the suction and discharge. The smallest pulley is put upon the motor, and a measurement of power, head, and discharge made, with the discharge

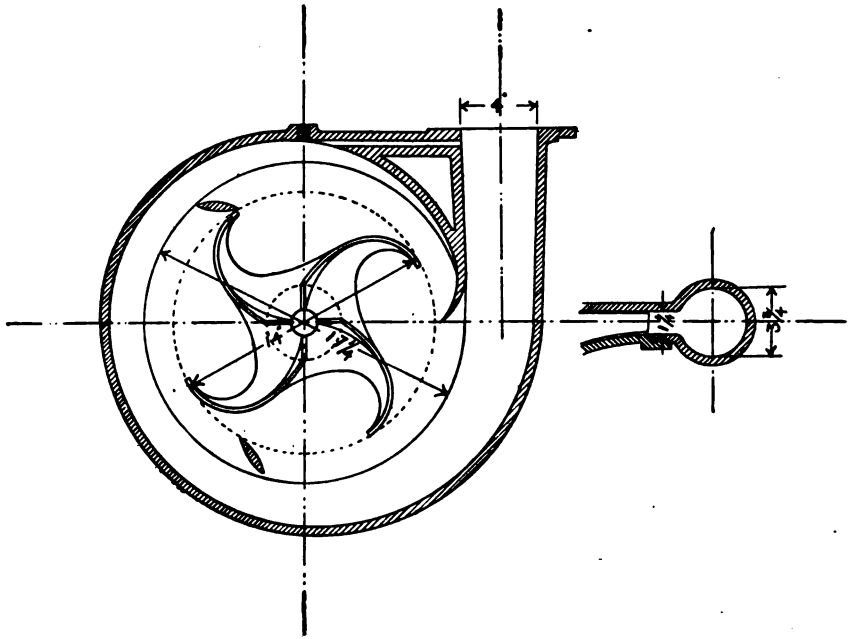

FIG. 19.—Section of centrifugal pump used in test No. 1.

valve wide open. The discharge valve is then partly closed, thus increasing the effective head, another measurement made, and so on till the valve is entirely shut. Meanwhile the speed is held constant by the rheostat. The next larger pulley is then placed on the motor, and a set of measurements made on a higher speed, and so on till the maximum capacity of the motor or weir is reached. The efficiency of the pump is thus determined from far below to far above its rated capacity.

In the following tables the pump speed is in revolutions per minute; the dynamometer horsepower is the actual horsepower applied to the pump by the belt; the total head pumped against is the sum of the readings of the two gauges corrected for errors, and expressed in feet of water, plus the difference in level between the gauges measured in feet; the hydraulic horsepower is the theoretical horsepower required to raise

the water through the given head; the efficiency is equal to the hydraulic horsepower divided by the dynamometer horsepower. This method of expressing the efficiency of a pump charges neither the friction head of the piping, nor the velocity head of the entering water against the pump. While the former is evidently a just requirement, since we are measuring the efficiency of pumps, and not schemes of piping, it is not so clear that the velocity head should not be charged against the pump. Still, since the addition of taper connections and enlarged discharge pipes, as are used on most modern plants, tend to eliminate this factor, and since the efficiency is usually expressed in this way, the definition has been retained.

## CENTRIFUGAL PUMPS.

*Test No. 1.*—No. 4 single-runner horizontal centrifugal pump with inlet and outlet diameters 4 inches; diameter of runner, 14 inches; type, open runner, diverging vanes; vortex obstructed at two points by bridging, and discharging into scroll. Pulley, 10 inches in diameter. This pump is of the open-runner type, that is to say, the runner consists of four blades or paddles, not connected in any way except at the hub. The general dimensions are shown in the sketch (fig. 19). The results of the test are given in the following table:

*Results of test No. 1.*

No.	Pump speed.	Dynamometer horsepower.	Discharge.	Total head.	Hydraulic horsepower.	Efficiency.
	<i>Revolutions per minute.</i>		<i>Cubic feet per second.</i>	<i>Feet.</i>		<i>Per cent.</i>
1	477	1.14	0.406	12.2	0.56	49.1
2	477	.54	0	12.7	0	0
3	604	2.83	.891	16.6	1.68	59.4
4	604	2.28	.587	19.1	1.27	55.7
5	604	1.07	0	19.2	0	0
6	727	5.06	1.221	22.4	3.11	61.5
7	727	4.38	.956	25.2	2.73	62.3
8	727	3.34	.735	26.5	2.21	56.1
9	727	3.30	.504	28.6	1.64	49.7
10	727	1.72	0	30.2	0	0
11	809	7.26	1.422	26.8	4.33	59.6
12	809	6.72	1.233	29.3	4.10	61
13	809	6.32	1.088	31.2	3.85	60.9
14	809	5.75	.938	32.5	3.46	60.2
15	809	5.10	.746	34.2	2.90	56.9
16	809	4.00	.438	35.8	1.78	44.5
17	809	2.28	0	36	0	0
18	964	12.79	1.806	35.5	7.28	57
19	964	11.98	1.641	38.3	7.14	59.6
20	964	11.12	1.441	41.7	6.82	61.3
21	964	10.19	1.252	44.8	6.37	62.5
22	964	9.31	1.028	47.5	5.54	59.5
23	964	6.95	.592	51.2	3.44	49.5
24	964	4.11	.093	51.3	.54	13.1
25	964	3.36	0	51.5	0	0
26	1,076	18.00	2.020	42.2	9.68	53.8
27	1,076	16.92	1.828	48	9.98	59
28	1,076	15.70	1.609	49.1	9.30	59.2
29	1,076	14.46	1.481	53.8	9.06	62.7
30	1,076	13.38	1.252	57	8.11	60.6
31	1,076	11.02	1.022	59.5	6.91	59.4
32	1,076	8.59	.528	63.2	3.79	44.1
33	1,076	4.78	0	63.5	0	0
34	1,170	19.36	1.669	61.8	11.70	60.4
35	1,170	18.40	1.502	66	11.25	61.1
36	1,170	16.22	1.221	69.9	9.69	59.7
37	1,170	13.76	.891	73.4	7.43	54
38	1,170	9.46	.429	74.5	3.63	36.8
39	1,170	6.09	0	75	0	0



The results of the test are best shown by the curves on figure 20. These curves are typical in form for a fairly designed centrifugal pump. By reference to them it will be observed that for every speed there is a definite head at which the pump works best, and, conversely,

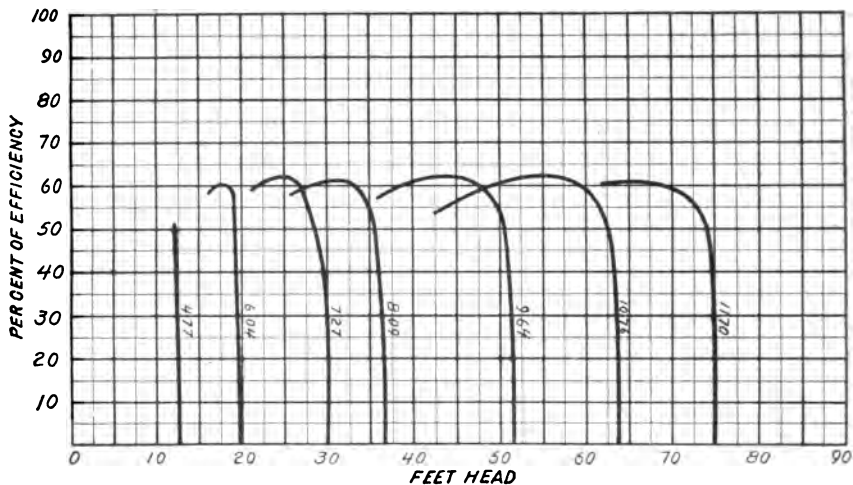

FIG. 20.—Efficiency curves, test No. 1.

for a given head there is a definite speed at which the pump works most efficiently. These matters can be better discussed when the tests on the other pumps of this type have been given.

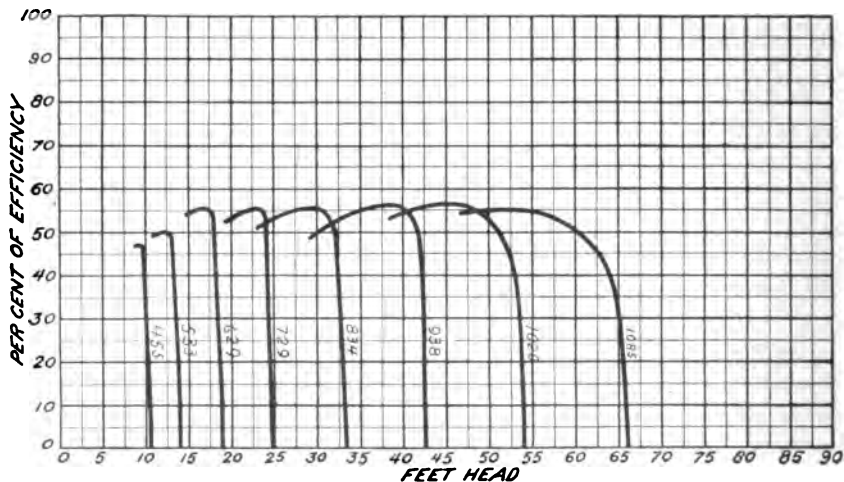

FIG. 21.—Efficiency curves, test No. 2.

*Test No. 2.*—The pump is a No. 4 single-runner horizontal centrifugal pump, similar to the first one tested, except that there is slightly different curvature to the runner blades. The results of the test are as follows.

Results of test No. 2.

No.	Pump speed.	Dynamometer horse-power.	Discharge.	Total head.	Hydraulic horse-power.	Efficiency.
	<i>Revolutions per minute.</i>		<i>Cubic feet per second.</i>	<i>Feet.</i>		<i>Per cent.</i>
1	455	1.09	0.411	9.8	0.49	45
2	455	.83	0	10.6	0	0
3	533	1.79	.686	11.5	.89	49.7
4	533	1.34	.361	13.4	.55	41
5	533	.71	0	13.8	0	0
6	629	3.09	.956	15.5	1.68	54.4
7	629	2.74	.762	17.3	1.50	54.7
8	629	1.93	.375	18.4	.78	40.4
9	629	1.05	0	18.9	0	0
10	729	5.21	1.221	19.8	2.75	52.8
11	729	4.94	1.106	21.4	2.69	54.4
12	729	4.36	.920	23.1	2.41	55.3
13	729	3.70	.691	24.2	1.90	51.4
14	729	2.56	.316	24.4	.97	34.2
15	729	1.54	0	24.7	0	0
16	834	7.64	1.441	24.4	4	52.3
17	834	6.90	1.227	26.8	3.74	54.2
18	834	5.89	.926	30.4	3.20	54.3
19	834	4.42	.592	32.3	2.17	49.1
20	834	2.93	.151	33	.57	19.4
21	834	2.09	0	33.5	0	0
22	938	11.55	1.669	30	5.78	50
23	938	10.50	1.474	33.9	5.68	54
24	938	9.62	1.272	36.9	5.33	55.4
25	938	8.18	.992	41.5	4.67	57.1
26	938	6.40	.633	42	3.02	47.2
27	938	3.08	0	42.5	0	0
28	1,020	14.35	1.733	38.3	7.52	52.4
29	1,020	13.54	1.573	41.5	7.41	54.7
30	1,020	12.74	1.396	42.5	6.68	52.4
31	1,020	11.09	1.176	47.3	6.32	56.9
32	1,020	9.33	.817	50.8	4.72	50.6
33	1,020	6.28	.357	53.5	2.17	34.5
34	1,020	4.26	0	53.7	0	0
35	1,085	16.76	1.704	47	9.09	54.2
36	1,085	15.74	1.502	49.6	8.46	53.7
37	1,085	14.52	1.309	53	7.88	54.3
38	1,085	12.39	1.040	56.3	6.65	53.7
39	1,085	9.94	.691	59.3	4.65	46.4
40	1,085	6.93	.257	65.6	1.91	27.6
41	1,085	5.14	0	66	0	0

The efficiencies given by this pump are distinctly lower than those given by the first one. The results are shown graphically in figure 21.

*Test No. 3.*—The pump is a No. 4 single-runner horizontal centrifugal pump. The inlet and outlet openings are 4 inches in diameter; both are in the axis of the pump; diameter of runner, 9 inches; type, closed runner; pulley, 6 inches; discharging against guide blades which carry the water back to axis and out. The results of the test are given in the table following.

Results of test No. 3.

No.	Pump speed.	Dynamometer horse-power.	Discharge.	Total head.	Hydraulic horse-power.	Efficiency.
	<i>Revolutions per minute.</i>		<i>Cubic feet per second.</i>	<i>Feet.</i>		<i>Per cent.</i>
1	1,089	0.39	a 0	0	0	0
2	1,089	4.30	.697	15.25	1.21	28.1
3	1,089	4.19	.623	16.2	1.15	27.4
4	1,089	4.03	.513	18.25	1.06	26.3
5	1,089	4.03	.406	20.1	.93	23.1
6	1,089	4.03	.274	21.7	.61	15.1
7	1,089	4.42	0	22.9	0	0
8	1,311	.52	a 0	0	0	0
9	1,311	7.33	.914	20.6	2.14	29.2
10	1,311	7.29	.833	21.7	2.05	28.1
11	1,311	7.07	.746	22.9	1.94	27.4
12	1,311	6.98	.660	24.3	1.82	26.1
13	1,311	6.86	.572	25.6	1.66	24.2
14	1,311	6.80	.494	27.7	1.55	22.9
15	1,311	6.90	.393	30	1.34	19.4
16	1,311	6.98	.290	32.3	1.06	15.2
17	1,311	7.33	.170	35.5	.65	8.9
18	1,311	7.33	0	35.3	0	0
19	1,458	.58	a 0	0	0	0
20	1,458	9.94	1.064	24.7	2.96	30.1
21	1,458	10	.908	27.5	2.84	28.4
22	1,458	9.94	.795	29.6	2.67	26.9
23	1,458	9.80	.681	32.1	2.48	25.3
24	1,458	9.49	.528	34.7	2.06	21.9
25	1,458	9.65	.438	36	1.79	18.5
26	1,458	9.76	.253	40.4	1.16	11.9
27	1,458	9.99	.179	42.5	.86	8.6
28	1,458	10.10	0	42.7	0	0
29	1,527	.60	a 0	0	0	0
30	1,527	11.77	1.131	25.9	3.33	28.3
31	1,527	11.66	1.016	28.7	3.31	28.4
32	1,527	11.44	.874	31.9	3.17	27.7
33	1,527	11.33	.746	34.9	2.96	26.1
34	1,527	11.37	.602	38.8	2.65	23.3
35	1,527	11.44	.429	42.5	2.07	18.1
36	1,527	11.74	.316	46	1.65	14.1
37	1,527	11.99	.138	49.7	.62	5.2
38	1,527	12.09	0	51.1	0	0

a Air test.

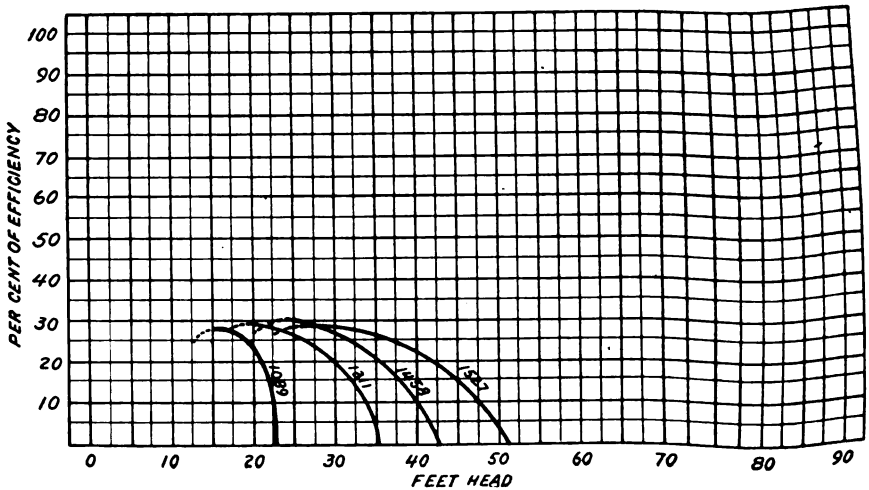

FIG. 22.—Efficiency curves, test No. 3.

The very low efficiency given by this pump appears to be due to two causes—obstruction of the discharge and circulation within the pump. Both of these are fatal to good operation. It will be noted that the pump requires as much or more power to drive it when the discharge valve is closed and it is delivering no water at all as when throwing its full stream. The whole power in the first instance is absorbed by friction and circulating currents, and these latter are more or less destroyed by the rush of the stream when wide open. The poor efficiency when pumping full open is due to obstructed discharge. It is to be regretted that the head could not have been still further

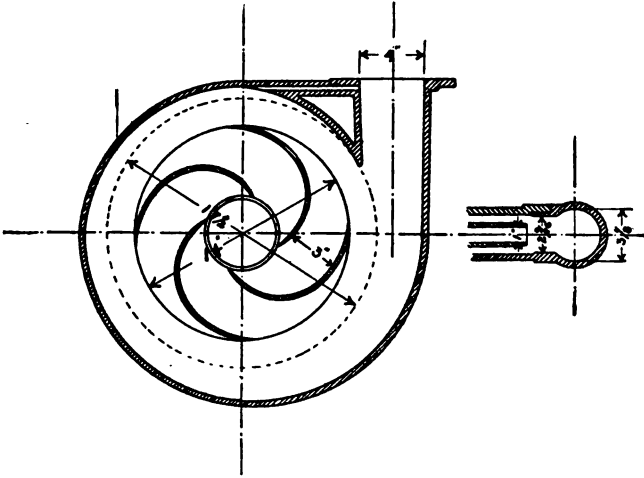

FIG. 23.—Section of pump used in test No. 4.

reduced, so as to give a clear maximum on the curves (fig. 22), but it is evident that the last points are quite near this maximum.

*Test No. 4.*—This is a No. 4 single-runner horizontal centrifugal pump, with inlet and outlet openings 4 inches in diameter; inlet axial, outlet tangential; diameter of runner, 14 inches; type, closed runner; pulley, 9 inches; discharging into scroll; no bridging. This pump has a closed runner of the ordinary type, “finished” on the outside only. The passages are rough cored (fig. 23). The results of the test are given in the table following.

Results of test No. 4.

No.	Pump speed.	Dynamometer horse-power.	Discharge.	Total head.	Hydraulic horse-power.	Efficiency.
	<i>Revolutions per minute.</i>		<i>Cubic feet per second.</i>	<i>Feet.</i>		<i>Per cent.</i>
1	550	1.69	0.602	15.6	1.06	62.1
2	550	1.58	.518	17	1	63.3
3	550	1.22	.307	18.4	.64	52.5
4	550	.66	0	18.8	0	0
5	696	3.54	.980	20.7	2.30	64.8
6	696	3.47	.920	21.8	2.28	65.7
7	696	3.29	.823	23.7	2.21	67.2
8	696	3.05	.713	25.4	2.06	67.5
9	696	2.80	.612	27.1	1.89	67.5
10	696	2.42	.471	28.8	1.54	63.6
11	696	2.03	.282	30.5	.96	48.3
12	696	1.27	0	30.8	0	0
13	800	5.26	1.221	26.8	3.61	68.6
14	800	5.05	1.082	28.5	3.50	69.3
15	800	4.71	.885	31.5	3.16	67.1
16	800	4.02	.697	35	2.77	68.9
17	800	3.22	.447	38.7	1.96	60.9
18	800	1.74	0	39.7	0	0
19	893	8.13	1.454	32.2	5.31	65.3
20	893	7.86	1.348	33.2	5.08	64.6
21	893	7.37	1.209	37.1	5.09	69.1
22	893	6.88	1.058	40.6	4.88	70.9
23	893	6.48	.908	43.6	4.49	69.4
24	893	5.72	.741	46.3	3.89	68
25	893	4.65	.499	49.3	2.79	60
26	893	2.77	0	52.3	0	0
27	1,004	10.93	1.607	34.8	6.35	58.1
28	1,004	10.83	1.573	38.5	6.88	63.5
29	1,004	10.53	1.461	42.4	7.02	66.7
30	1,004	10.28	1.322	45.8	6.88	66.9
31	1,004	9.83	1.215	49.3	6.80	69.2
32	1,004	9.36	1.113	51.4	6.49	69.3
33	1,004	8.71	.938	54.6	5.82	66.8
34	1,004	7.82	.789	57.8	5.18	66.2
35	1,004	6.41	.574	61.1	3.80	59
36	1,004	3.43	0	63.9	0	0
37	1,102	14.10	1.676	35.5	6.76	47.9
38	1,102	14.10	1.669	39	7.39	52.4
39	1,102	13.90	1.627	48.6	8.98	64.6
40	1,102	13.61	1.530	51.6	8.97	65.9
41	1,102	12.85	1.376	55.8	8.72	67.9
42	1,102	12.07	1.196	61.3	8.32	68.9
43	1,102	11.02	.986	66.4	7.43	67.4
44	1,102	9.32	.697	71.1	5.62	60.3
45	1,102	6.23	.310	74	2.61	41.9
46	1,102	4.63	0	76.1	0	0

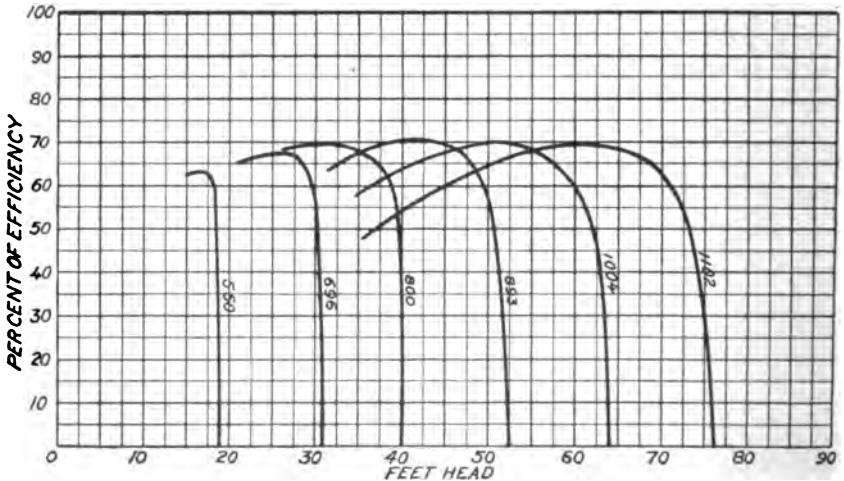

Fig. 24.—Efficiency curves, test No. 4.

The efficiency curves are of the ordinary type (fig. 24). It will be noticed that the highest value reached is about 71 per cent when running at 893 revolutions per minute on 40.6-foot head.

*Test No. 5.*—The pump was a No. 4 single-runner horizontal centrifugal pump, with inlet and outlet 4 inches in diameter; inlet axial; outlet tangential; diameter of runner, 18 inches; type, closed runner;

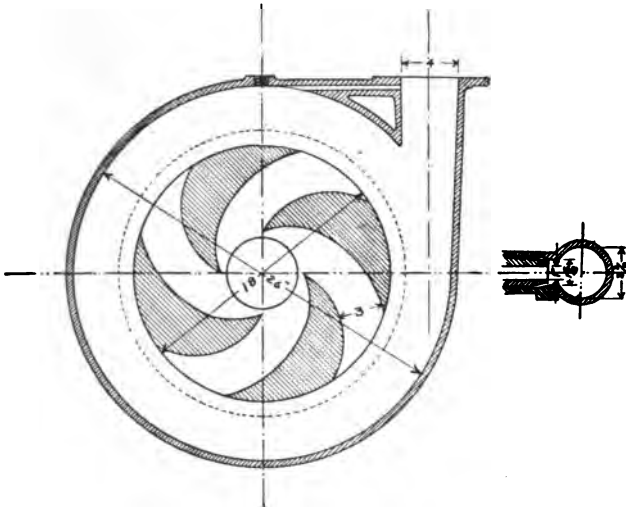

FIG. 25.—Section of pump used in test No. 5.

pulley, 10 inches; discharging into scroll, no bridging (fig. 25). This runner is “finished” on the outside, and one side of the inside channels is “finished.” The results of the test are as follows:

*Results of test No. 5.*

No.	Pump speed.	Dynamometer horse-power.	Discharge.	Total head.	Hydraulic horse-power.	Efficiency.
	<i>Revolutions per minute.</i>		<i>Cubic feet per second.</i>	<i>Feet.</i>		<i>Per cent.</i>
1	627	5.98	1.329	23.5	3.55	59.4
2	627	5.82	1.202	26.2	3.58	61.5
3	627	5.57	1.082	27.9	3.43	61.6
4	627	5.18	.956	29.9	3.24	62.5
5	627	4.89	.833	31.8	3.01	61.5
6	627	4.34	.660	33.6	2.52	58
7	627	2.20	0	37.5	0	0
8	726	9.44	1.601	29.5	5.36	56.8
9	726	9.35	1.544	30.9	5.42	58
10	726	9.27	1.467	32.9	5.48	59
11	726	8.70	1.316	36.4	5.44	62.5
12	726	7.94	1.106	39.3	4.94	62.2
13	726	7.30	.891	42.6	4.31	59
14	726	6.05	.623	46.3	3.27	54
15	726	2.78	0	50.6	0	0
16	804	12.73	1.669	39.2	7.43	58.4
17	804	12.28	1.523	42.3	7.32	59.6
18	804	11.56	1.389	45.6	7.19	62.2
19	804	10.80	1.221	49.1	6.81	63
20	804	9.96	.998	52.6	5.96	59.8
21	804	8.57	.778	56.2	4.96	57.9
22	804	3.88	0	62.8	0	0
23	905	16.23	1.488	60.2	10.15	62.5
24	905	15.22	1.309	63.8	9.55	62.8
25	905	14.38	1.137	67.4	8.71	60.6
26	905	12.67	.908	71.0	7.32	57.8
27	905	10.7	.623	74.8	5.29	49.5
28	905	6.14	0	81.0	0	0

Figure 26 shows the efficiency curves as determined by this test. These five efficiency tests are the only ones so far completed on centrifugal pumps. Additional tests on the fourth pump were made to determine whether air, churned up in the supply tank by the returning discharge from the weir, reached the suction pipe of the pump and affected the efficiency, and whether the efficiency of a pump working on a definite head and speed was affected by the way in which that head is distributed between the suction and discharge.

The first of these is easily tested by running a test in the ordinary way and then turning the discharge into some other tank and repeating the test. The results in the two cases were found to be identical, showing that the tests had in no way been affected by the air of the return. The same thing was tried on another pump, with similar

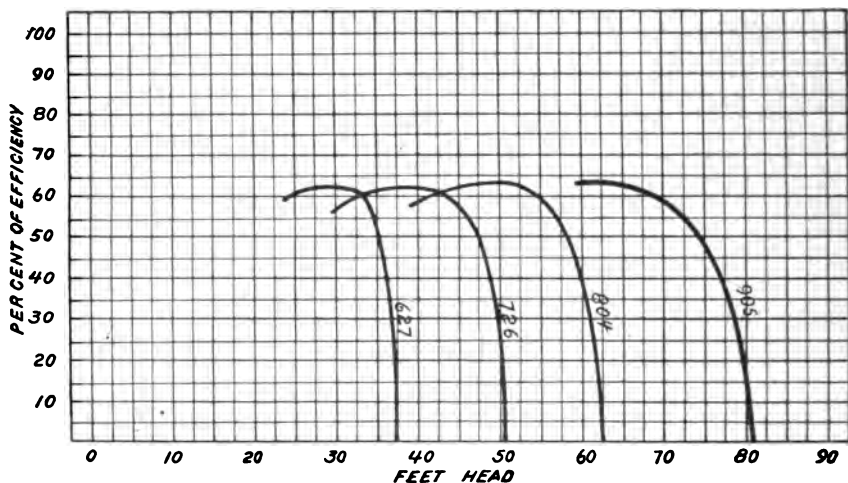

FIG. 26.—Efficiency curves, test No. 5.

results. This might have been predicted from the fact that the suction takes its water from a point 6 feet distant from the point of return and 6 feet below the surface.

The second was tested in the following manner: A gate valve was placed in the suction, as well as in the discharge. By this means a given total head could be maintained, and at the same time distributed in any way between the suction and discharge. The results showed that the distribution of the head between suction and discharge had no effect on the efficiency of the pump. The pump was well packed in this instance, but an imperfect packing of the gland would doubtless have shown a variation in favor of the low suction head.

#### TRIPLEX PLUNGER PUMPS.

*Test No. 6.*—The pump tested was a single-acting triplex pump, 2-standard style, with plungers 5.5 inches in diameter; 6-inch stroke;

inlet opening, 5 inches in diameter; outlet, 4 inches in diameter; ratio of gearing, 5 to 1; pulley, 24 by 6 inches. This is a fair type of the triplex pump, having, however, but two standards. This does not give the steadiness of double-gearred four-standard type. The water in all cases was measured with the greatest possible care in the standard measuring tank. The total number of revolutions for the entire test was taken on a revolution counter, and the speed deduced therefrom. The pressure was measured on an 8-inch test gauge, or on the platform-gauge tester direct. The latter was found best on account of excessive vibrations at high heads, which made the reading of an ordinary gauge almost impossible. Since the efficiency of a plunger

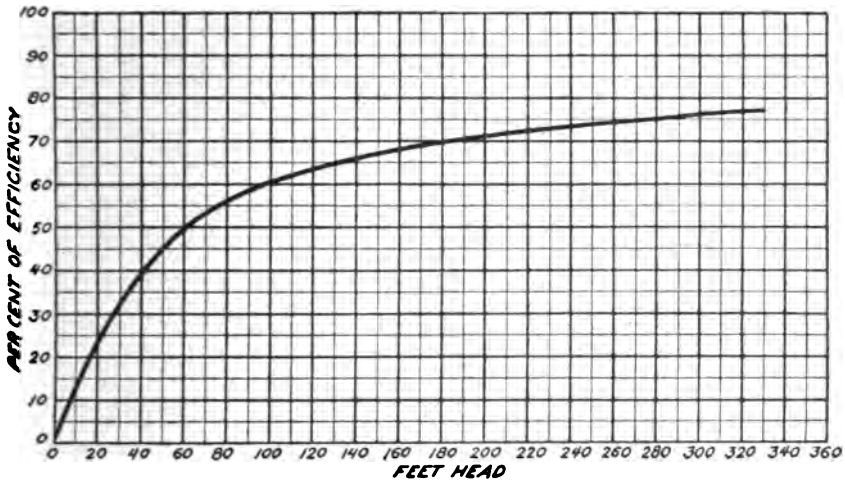

FIG. 27.—Efficiency curve, triplex pump, test No. 6.

pump is not intimately connected with the speed, as is that of the centrifugal, the test was made at but one speed. The test resulted as follows (fig. 27):

*Test of 5½ by 6 inch triplex pump.*

No.	Pump speed.	Dynamometer horse-power.	Discharge by tank.	Discharge by displacement.	Percentage of slip.	Total head.	Hydraulic horse-power.	Efficiency.
	<i>Revolutions per minute.</i>		<i>Cubic feet per second.</i>	<i>Cubic feet per second.</i>		<i>Feet.</i>		<i>Per cent.</i>
1 .....	64.8	2.83	0.262	0.267	1.87	32.4	0.96	33.8
2 .....	64.8	4.13	.262	.267	1.87	76.2	2.26	54.8
3 .....	64.6	5.71	.260	.266	2.25	122.5	3.62	63.3
4 .....	63.4	7.14	.255	.261	2.30	168.7	4.88	68.4
5 .....	64.8	8.89	.260	.267	2.62	215	6.35	71.4
6 .....	64.6	10.06	.260	.266	2.25	261	7.70	76.6
7 .....	64.5	12.17	.260	.266	2.25	307.2	9.07	74.5
Mean .....					2.20			

It is seen here that the efficiency increases rapidly with the head. This is, however, largely a matter of packing. A plunger pump should be packed only tight enough for the particular head under



which it is used. It is probable that the glands were packed too tight for low heads in this pump. The pump was tested just as received from the manufacturer.

*Test No. 7.*—This test was made with a single-acting triplex pump, 2-standard style, with plungers 4 inches in diameter; 6-inch stroke; inlet, 3 inches in diameter; outlet, 2.5 inches in diameter; ratio of gearing, 5 to 1; pulley, 20 by 4 inches. The test resulted as follows:

*Test of 4 by 6 inch triplex pump.*

Number.	Pump speed.	Dynamometer horse-power.	Discharge by tank.	Discharge by displacement.	Percentage of slip.	Total head.	Hydraulic horse-power.	Efficiency.
	<i>Revolutions per minute.</i>		<i>Cubic feet per second.</i>	<i>Cubic feet per second.</i>				
1 .....	64.4	1.77	0.1361	0.1405	3.14	11.1	0.17	9.7
2 .....	63.8	3.19	.1359	.1392	2.37	100	1.54	48.4
3 .....	63.3	4.30	.1338	.1380	3.04	170	2.58	60
4 .....	63.4	5.42	.1312	.1384	3.04	239	3.64	67.1
5 .....	63.9	6.86	.1348	.1394	3.87	309	4.73	69
Mean .....					3.09			

The resulting curve of efficiency is shown in figure 28. This shows a lower efficiency than No. 6, necessarily true, other things being

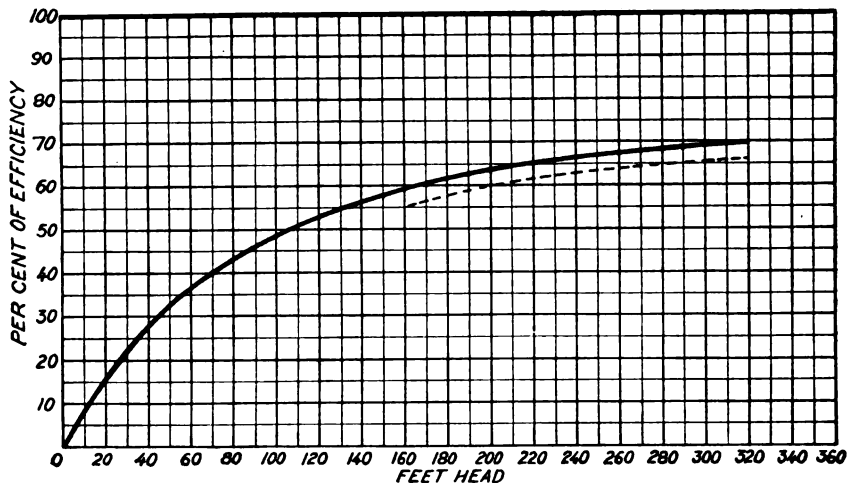

FIG. 28.—Efficiency curve, triplex pump, test No. 7.

equal, on account of the smaller size of the pump. The effect of tight packing is well shown in the figure. The full-line curve shows the efficiency when first received and tested the same day. The lower dotted curve shows part of the efficiency curve taken a few days later, when the packing had become water-soaked and swelled.

### CONCLUSIONS.

The principal results of the field tests may now be brought together for purposes of comparison.

Summary of results of field tests of pumping plants.

Name of owner.	Kind of power.	Kind of pump.	Head (measured).	Discharge per minute on test.	Speed on test per minute.	Kind of fuel.	Cost of fuel, or electrical energy.	Fuel cost of pumping 1,000,000 foot-gallons.	Remarks.
			(feet)	Galls.	Rev.			(cents)	
Mrs. S. L. Winchester	Gasoline.	Centrifugal.	69	975	725	Engine discharge.	12 cents per gal.	16.7 cents.	16.7.
J. C. Lewis	do.	do.	31	796	690	do.	114 cents per gal.	15.1 cents.	15.8
Wm. Bogen	do.	do.	89	338	760	do.	do.	25 cents.	26.1
S. K. Jackson	do.	do.	80	427	960	do.	101 cents per gal.	15.8 cents.	18
S. H. Shelley (1)	do.	do.	87	229	830	Coal-gas discharge.	5 cents per gal.	11.5 cents.	27.6
do.	do.	do.	56	444	710	do.	do.	7.8 cents.	18.8
Darrell & Schumacker	do.	do.	31	727	757	Engine discharge.	104 cents per gal.	18.5 cents.	22.2
Hermosa Plant	do.	Piston.	145	390		do.	12 cents per gal.	15.7 cents.	15.7
Chase Nursery	do.	Triplex.	200	848		do.	94 cents per gal.	7.7 cents.	9.8
Sunnyside Water Co.	Electric	Centrifugal.	150	348	870	do.	\$50 per horse-power year.	7.6 kilowatt hours.	19
Do.	do.	do.	121	478	872	do.	do.	7.4 kilowatt hours.	18.5
Hall's Caledonian Colony	do.	do.	34	426	1,190	do.	do.	7.8 kilowatt hours.	19.5
Miss Ruby Johnson	do.	do.	82	103	1,175	do.	do.	12.3 kilowatt hours.	30.7
Lindsay Water and Development Co.	do.	do.	63	763	864	do.	do.	7.1 kilowatt hours.	17.7
Do.	do.	do.	63	1,123	864	do.	do.	5.9 kilowatt hours.	14.7
Norcross & Crane	do.	do.	41	252	1,170	do.	do.	7.4 kilowatt hours.	18.6
Temescal Water Co., Peyton	do.	Triplex.	36	1,232		do.	do.	6.6 kilowatt hours.	16.6
Temescal Water Co., Station E.	do.	Centrifugal.	53	544	590	do.	do.	9.2 kilowatt hours.	23
Temescal Water Co., Station No. 1.	do.	do.	54	489		do.	do.	7.4 kilowatt hours.	18.5
Temescal Water Co., Station No. 2.	do.	do.	50	1,286		do.	do.	9.4 kilowatt hours.	23.5
Temescal Water Co., Station No. 4.	do.	do.	50	1,264		do.	do.	7.3 kilowatt hours.	18.2
O. F. Von Dorsten	Steam	do.	88	936	800	Crude oil	75 cents per barrel.	9 cents.	9
H. Booksin	do.	do.	55	1,653	515	do.	do.	6.5 cents.	6.5
Floyd Lundy	do.	do.	71	591	845	do.	do.	10.1 cents.	10.1

Running under speed; high suction.  
 Pump throttled; motor underloaded.  
 Pump overloaded, motor underloaded.  
 Head low for triplex.  
 Running under speed.  
 Not actually tested.  
 Do.  
 Do.  
 Do.  
 Do.

In looking over this table it will be noticed that the cost per 1,000,000 foot-gallons with gasoline engines (uniform rating) varies from 9.8 cents to 27.8 cents. The first of these is obtained with a large and expensive equipment, and the latter with a worn and leaking pump in a small station. The mean cost with good stations of moderate size seems to be about 16 cents. For electric plants the cost varies from 5.9 kilowatt hours to 12.3 kilowatt hours, or from 14.7 cents to 30.7 cents (uniform rating).<sup>a</sup> The mean value for the best plants appears to be about 7 kilowatt hours, or 17.5 cents. For steam plants of from 40 to 100 horsepower 9 cents per 1,000,000 foot-gallons should cover the cost of fuel. It is interesting to note how these compare with results obtained from the known efficiencies of the machinery. The actual power necessary to raise 1,000,000 foot-gallons in an hour is 4.21 horsepower. The efficiency of a good centrifugal pump, if running at exactly the correct speed, should easily reach 65 per cent. Allowing, however, for friction in pipes, check valves, and lost velocity head, it will not rise much over 60 per cent, and in fact few rise so high. This requires, then, 7 brake horsepower on the engine or motor. A new engine, perfectly adjusted, will run on one-eighth gallon of distillate per brake horsepower per hour, but it has been our experience that an engine in service some-time, and perhaps not in the best adjustment, consumed more like one-sixth gallon per indicated horsepower per hour, or, say, 0.17 gallon per brake horsepower per hour. Hence, to develop 7 brake horsepower will require 1.19 gallons of distillate, which, at 12 cents per gallon, costs 14.3 cents. No centrifugal plant which we tested fell to so low a value as this, the difference being due to lower efficiencies of engine and pump than assumed here. Furthermore, 7 brake horsepower is equal to about 8.2 electrical horsepower at the meter, or 6.14 kilowatts. One of the plants tested fell even below this. Finally, 7 brake horsepower means about 7.8 indicated horsepower in a steam engine cylinder. A good engine of, say, 50 horsepower should give a horsepower hour on 30 pounds of water. A fair tubular boiler should evaporate 11 pounds of water with a pound of oil. Hence, the 7.8 indicated horsepower for an hour should be made with 21.3 pounds of oil. A barrel of oil weighs about 335 pounds and costs, say, 75 cents. Hence, the cost of pumping 1,000,000 foot-gallons should not exceed 4.8 cents. All stations tested considerably exceeded this.

The main quantities which affect the final result, so far as the machinery alone is concerned, are: First. Size of plant. The larger the plant the more efficiently it will perform. This holds for both engine and pump. Second. The condition of carrying full-rated load

---

<sup>a</sup> Uniform rating taken at 12 cents per gallon for distillate and at 2½ cents per kilowatt hour for electrical energy.

on both engine and pump. An engine too large for its work is running uneconomically. Third. The most direct possible transmission between engine and pump. Fourth. Large suction and discharge pipes, with the fewest possible number of bends. Fifth. Care, cleanliness, and intelligence in operation. More expense is incurred by neglect of the last precaution than all others combined. Minor considerations are a low suction lift and a free check or foot valve.

In selecting the kind of power it must be borne in mind that fuel is far from being the only cost incurred. An electric motor, for example, costs practically nothing for attendance and repairs. A gasoline engine costs but little for attendance when in good running condition, but may run up a large bill for repairs if not intelligently handled. A steam plant requires an engineer constantly in charge, and wages here become a large item. But, on the other hand, a good engineer insures the proper care that machinery of this class should have. The conditions are so varied in different localities that no fair decision can be reached as to which of these forms of power is preferable, but the most general possible statement, which must be taken with many qualifications, is as follows: When electric power is obtainable, it is best. For small plants not so favored the gasoline engine is the only resource, while for large plants a good steam engine may give better satisfaction in the long run. For very large installations, or where many farms combine interests for pumping purposes, the steam central station, with electric distributing system, is by far the best.

The accompanying diagrams may help the prospective irrigator in estimating roughly the cost of installation and operation (fuel only) of a proposed pumping plant.

There must first be known the area to be irrigated (acres), the depth of one irrigation (inches), and the time in which it is necessary to apply this water. These latter items are not within the province of the present chapter, and must be taken from a knowledge of the duty of water in the particular locality desired. Knowing, however, the first two of these, the total amount of water, in million gallons, is at once taken from the diagram (fig. 29). For example, if 80 acres is to be covered 6 inches deep with water the resulting amount is 13,000,000 gallons. The third item may be given either in the actual number of hours of pumping, or in the number of days, together with the number of hours which constitute a day's run. These being known, the quantity to be discharged per minute can be read from figure 30. For instance, if the 13,000,000 gallons is to be pumped in twenty days, running fourteen hours per day, the course of the dotted line of the figure brings us to 760 gallons per minute, the required capacity of the pump. On this depends in a measure the size of the pump, which may be taken from the builders' rating, or, if the pump be a centrifugal, directly from figure 30. For example, in the

case just cited, 760 gallons per minute lies between the lines shown for a No. 5 and a No. 6 pump. Hence the latter would probably be taken. This determination of size is only approximate, as centrifugals will work very well considerably above their normal rating.

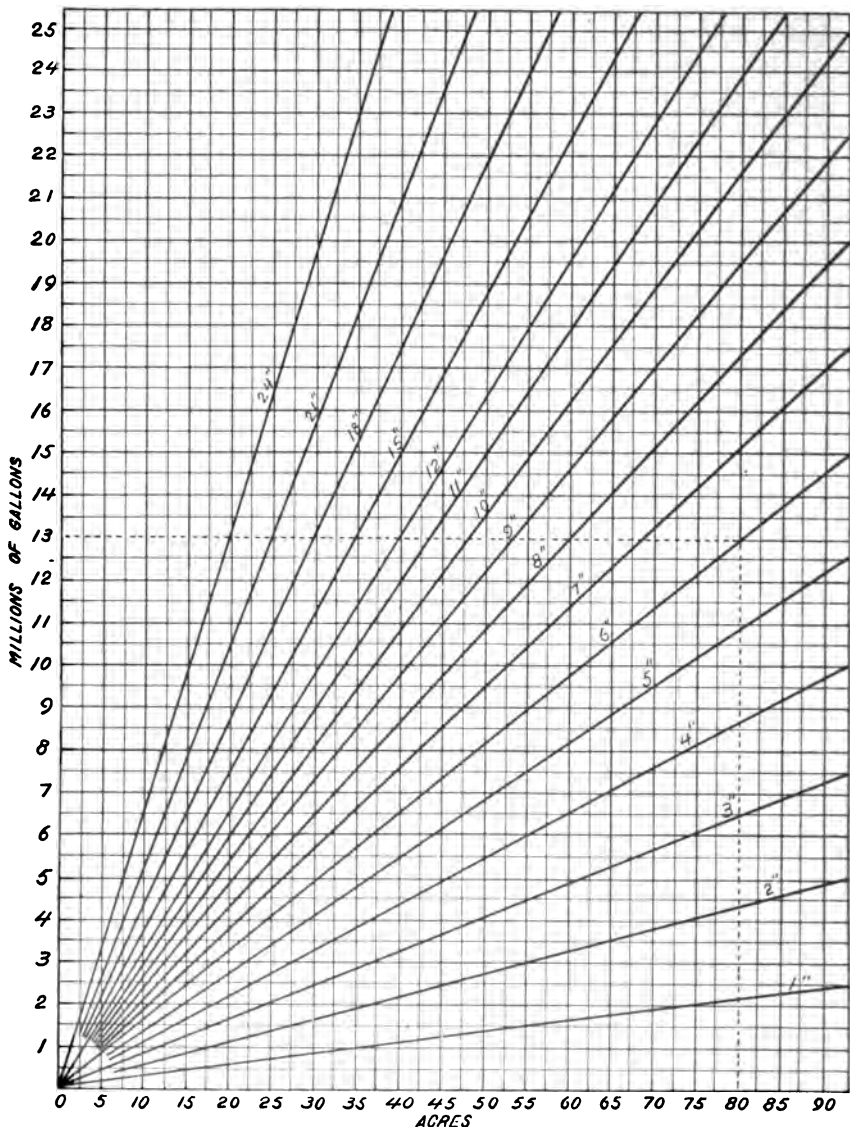

FIG. 29.—Millions of gallons of water required to cover a given area to a given depth.

Sizes of plungers and the other types of pumps must be taken from the builders' rating.

Now, in order to calculate the power to drive the pump, it is necessary to know the total lift under working conditions. This should

not be taken from the mere standing level in the surrounding country before pumping is commenced, but from the final level that the water takes up after pumping has been carried on for some time. The best way to find this is to hire a portable plant and run a test for several

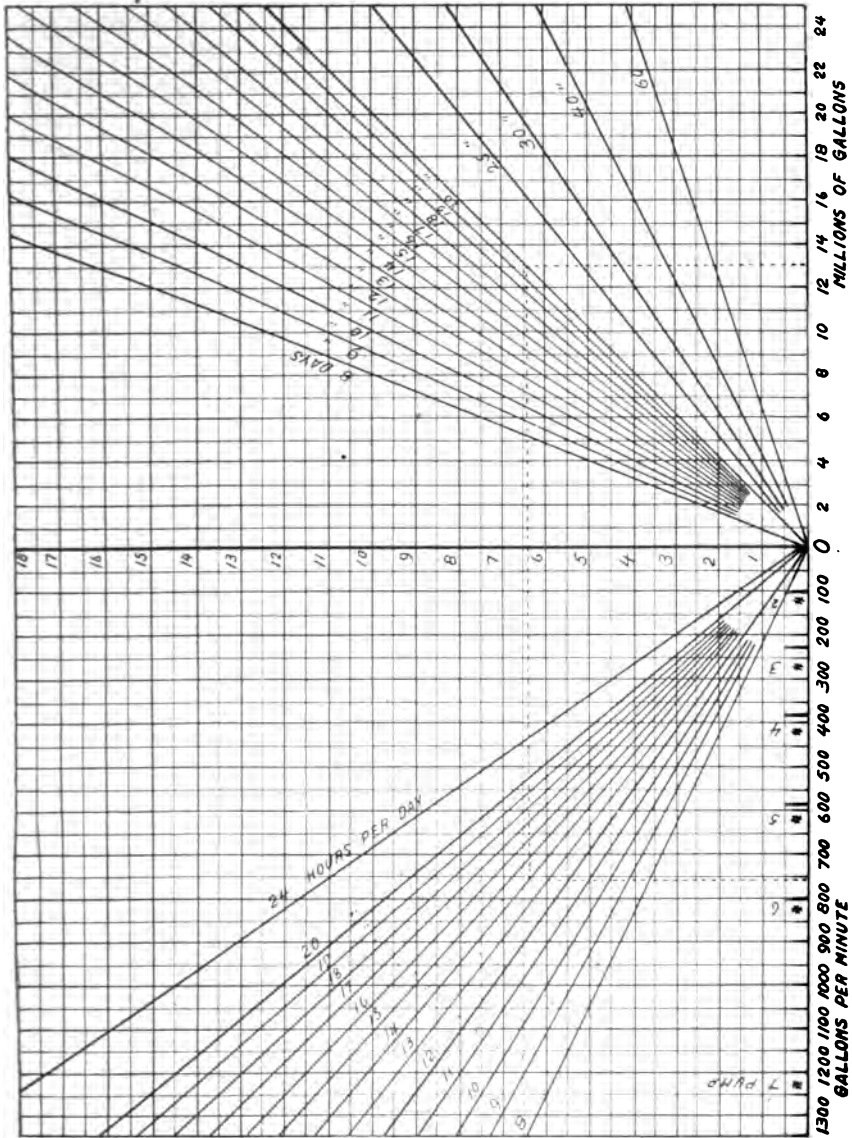

Fig. 30.—Gallons per minute required to supply a given quantity of water in a given time.

days. If this can not be done the level should be estimated by noting the fall in ground water in neighboring plants. Reference to the field tests will show that the gross efficiency of the average centrifugal pumping plant seldom exceeds 50 per cent, rated from the brake horse-

power. Reference to the case cited on page 238 shows that this should reach 60 per cent or over, but, allowing something for probable drop in the level of the suction and other possible defects, we will figure

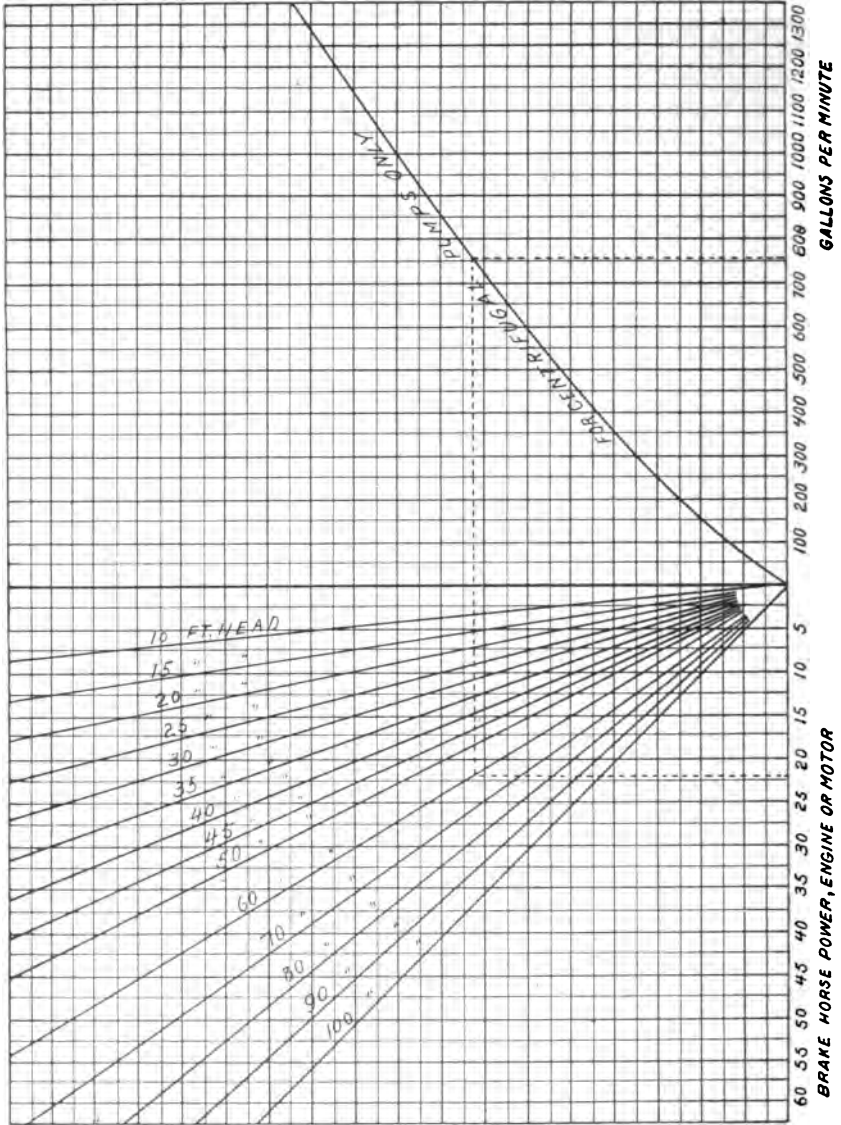

FIG. 31.—Brake horsepower necessary to lift given quantities of water.

our engine size (brake horsepower) on a 50 per cent efficiency for a No. 6 pump. Larger pumps will give higher and smaller ones lower efficiencies. Therefore, for a centrifugal pumping plant, the neces-

sary brake horsepower, by which engines and motors are rated, can be taken from figure 31. For instance, with the discharge of 760 gallons per minute and lift of 60 feet, we find the brake horsepower necessary will be 22.

Having now the main dimensions of the proposed plant the cost of the machinery becomes the next factor. Taking first the cost of the pump we may get a rough idea from the annexed diagram (fig. 32). For example, one No. 6 pump will cost, f. o. b. San Francisco, \$160. This is the pump only, including, however, a foot valve and pulley. Similarly for the engine. If a gasoline engine be used we get an idea

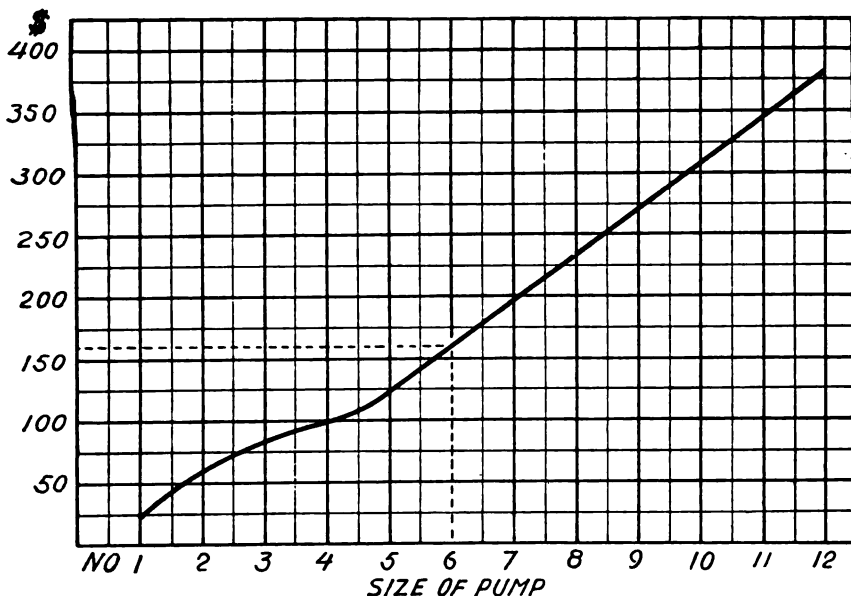

FIG. 32.—Approximate cost of centrifugal pumps.

of the cost of a first-class engine of ordinary type from figure 33, if it be less than 12 horsepower, or from figure 34, if it be over 12 horsepower.

In the figures the upper curve represents approximately the highest prices paid for such engines, and the lower the lowest prices. The heavy curves between are the average prices paid. The diagrams do not include, however, certain specially high-priced gas engines, nor do they include very cheap engines. The powers corresponding to the short heavy lines are the ones which may be found in stock. If the required power falls between two of these the next higher must be taken. Taking again the example which we are carrying through, we find that the cost of an engine of about 25-brake horsepower would be \$1,200, f. o. b. San Francisco. Figure 35 gives exactly the same



data on induction motors. For instance, the nearest motor to our required 22 horsepower is 30 horsepower, and the cost of this will be

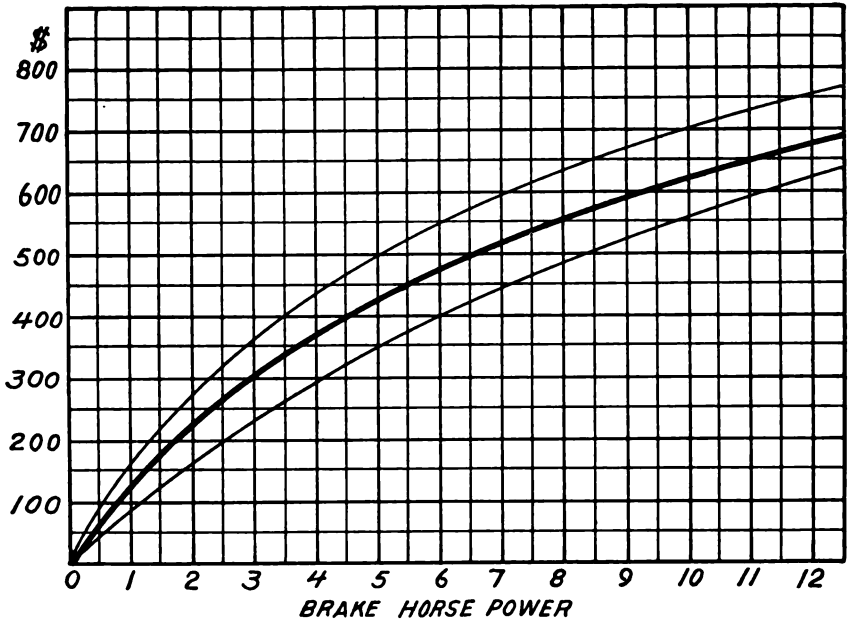

FIG. 33.—Approximate cost of small gasoline engines.

about \$800.<sup>a</sup> The prices of steam engines and boilers are so varied, and the data so far obtained are so limited, that no curves can be given

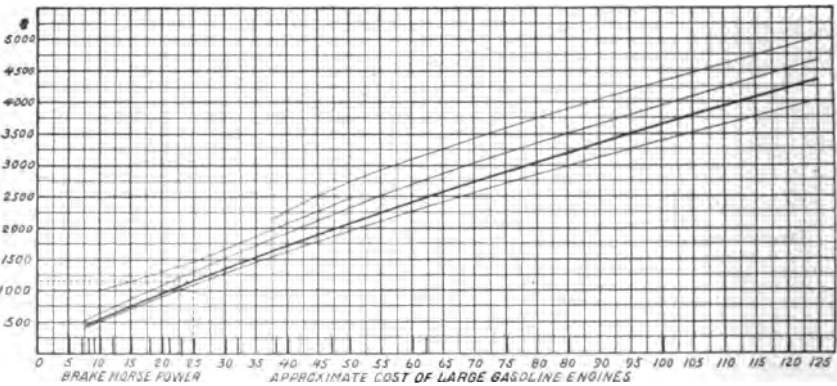

FIG. 34.—Approximate cost of large gasoline engines.

for them. The same applies to the cost of boring the wells. In the most general terms it may be stated that the cost for machinery and

<sup>a</sup>These are approximately figures for July, 1904. The price of induction motors has been very greatly reduced during the past year.

erection alone should not exceed \$80 per horsepower, and for the entire plant, including wells and building, \$100 per horsepower.

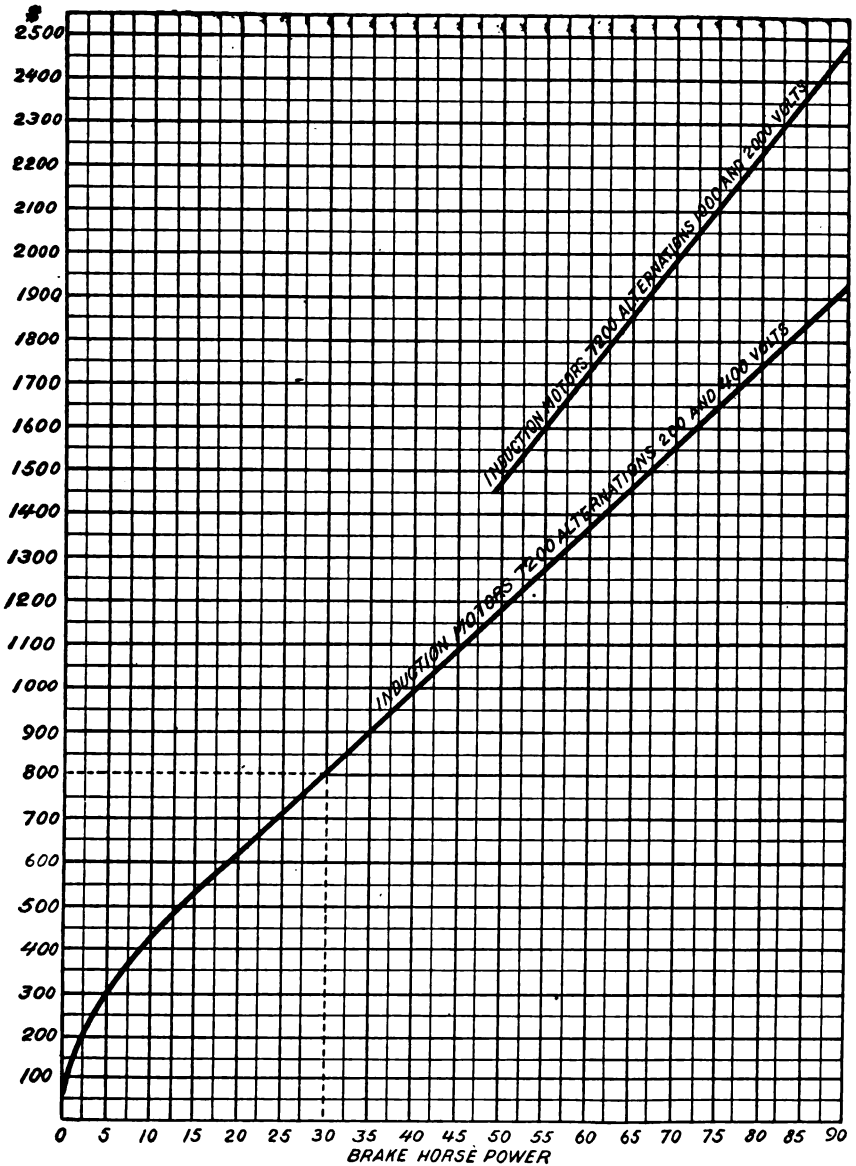

FIG. 35.—Approximate cost of induction motors.

As to the cost of producing power a more exact statement can be made. Reference to figure 36 will give the cost in cents per hour for

fuel, which should not be exceeded in a well-designed plant using a good gasoline engine and centrifugal pump. For example, such a

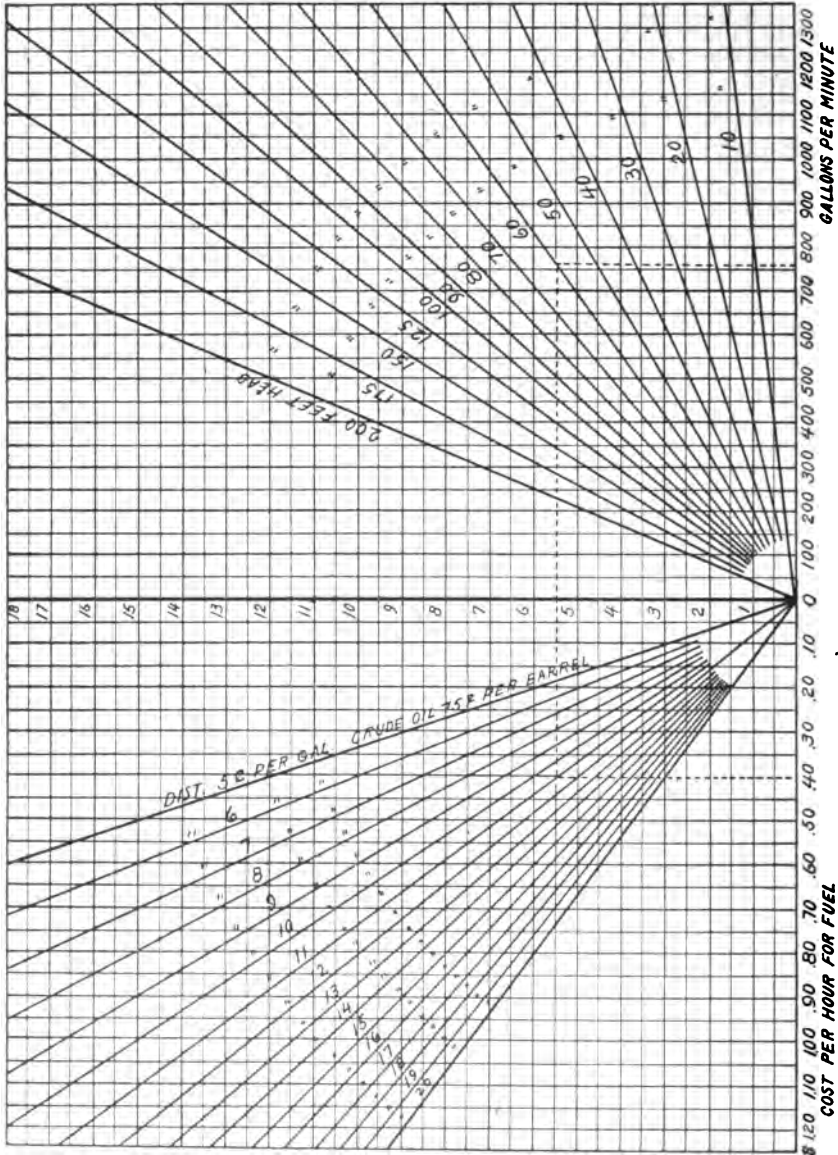

Fig. 36.—Cost of fuel per hour with gasoline pumping plants.

plant lifting 760 gallons per minute to a height of 60 feet, with engine distillate at 11 cents per gallon, should not cost over 40 cents per hour

to run (fuel only). The same plant electrically operated (fig. 37) should not take over 19 kilowatts to run, and if power be bought by

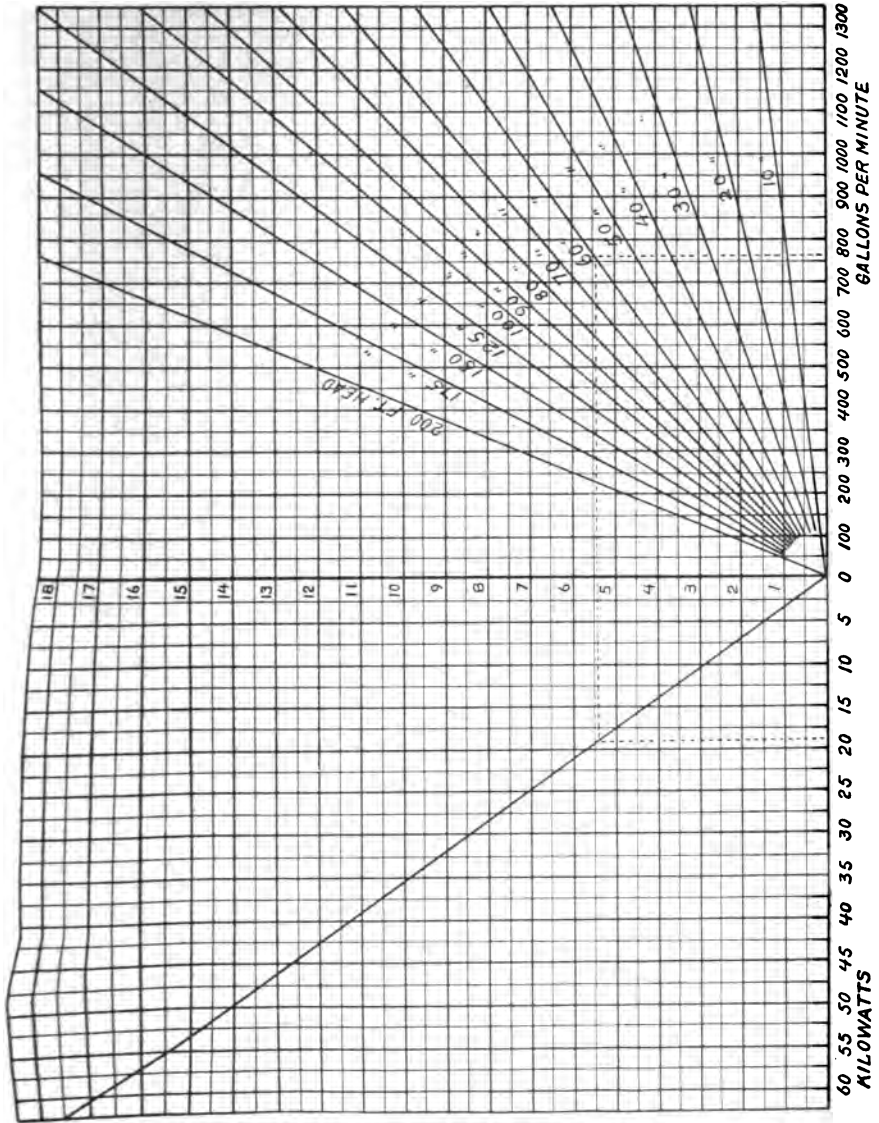

FIG. 37.—Electrical energy necessary for operating pumping plants.

meter at the rate of 2.5 cents per kilowatt hour (fig. 38) it should not cost over 48 cents per hour, but if the rate is 6 cents per kilowatt

hour the cost will be nearer \$1.14 per hour. Similarly, if a flat rate of \$50 per horsepower year be charged, and it is run two thousand

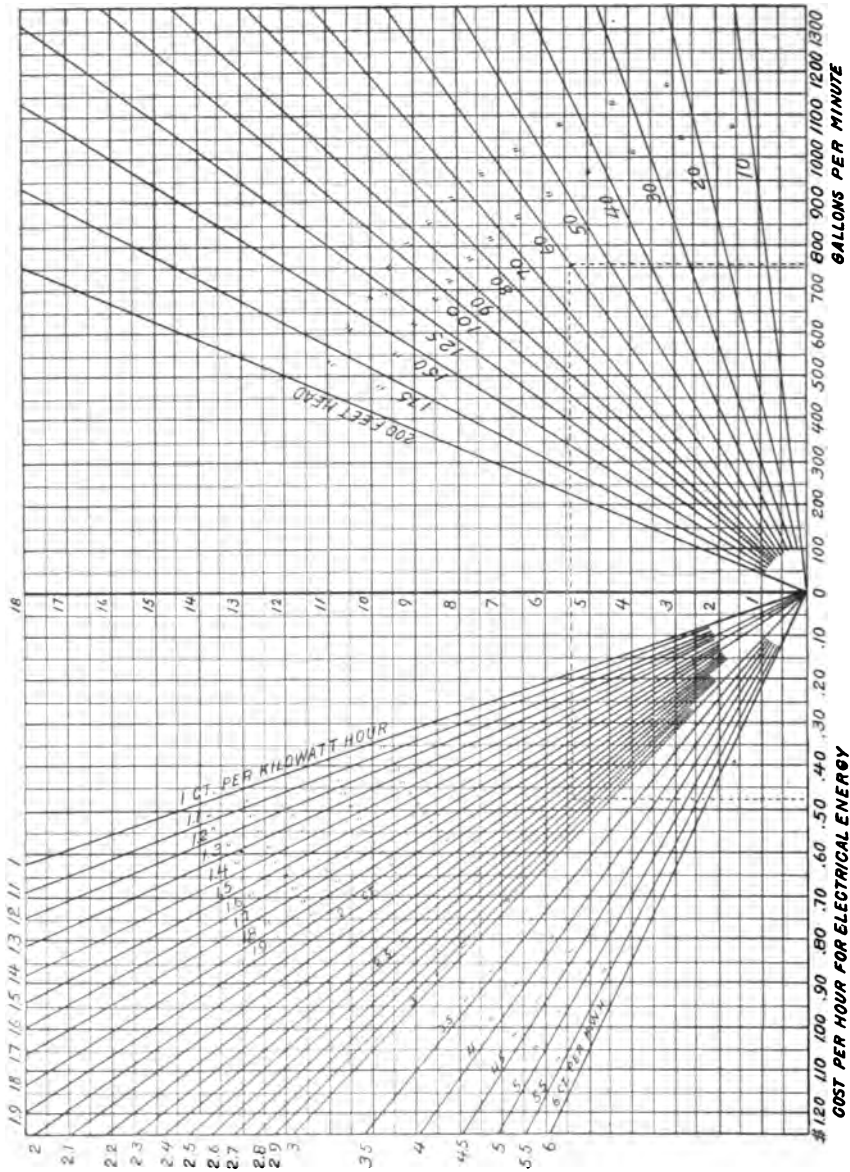

FIG. 38.—Cost of power per hour for electric pumping plants at meter rates.

five hundred hours in the year, then from figure 39 the cost should not exceed 51 cents.

It must be understood that these figures are approximate only, and are not intended to represent what any plant may do, but a limit

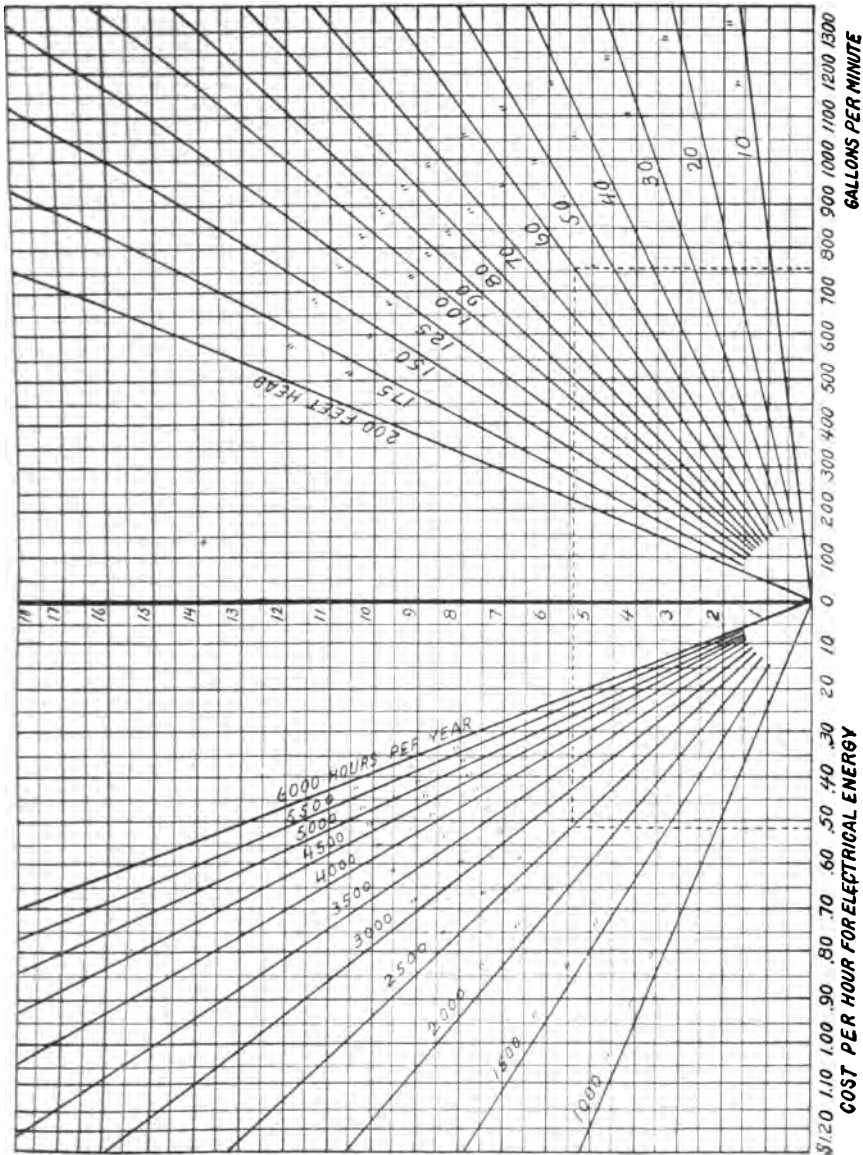
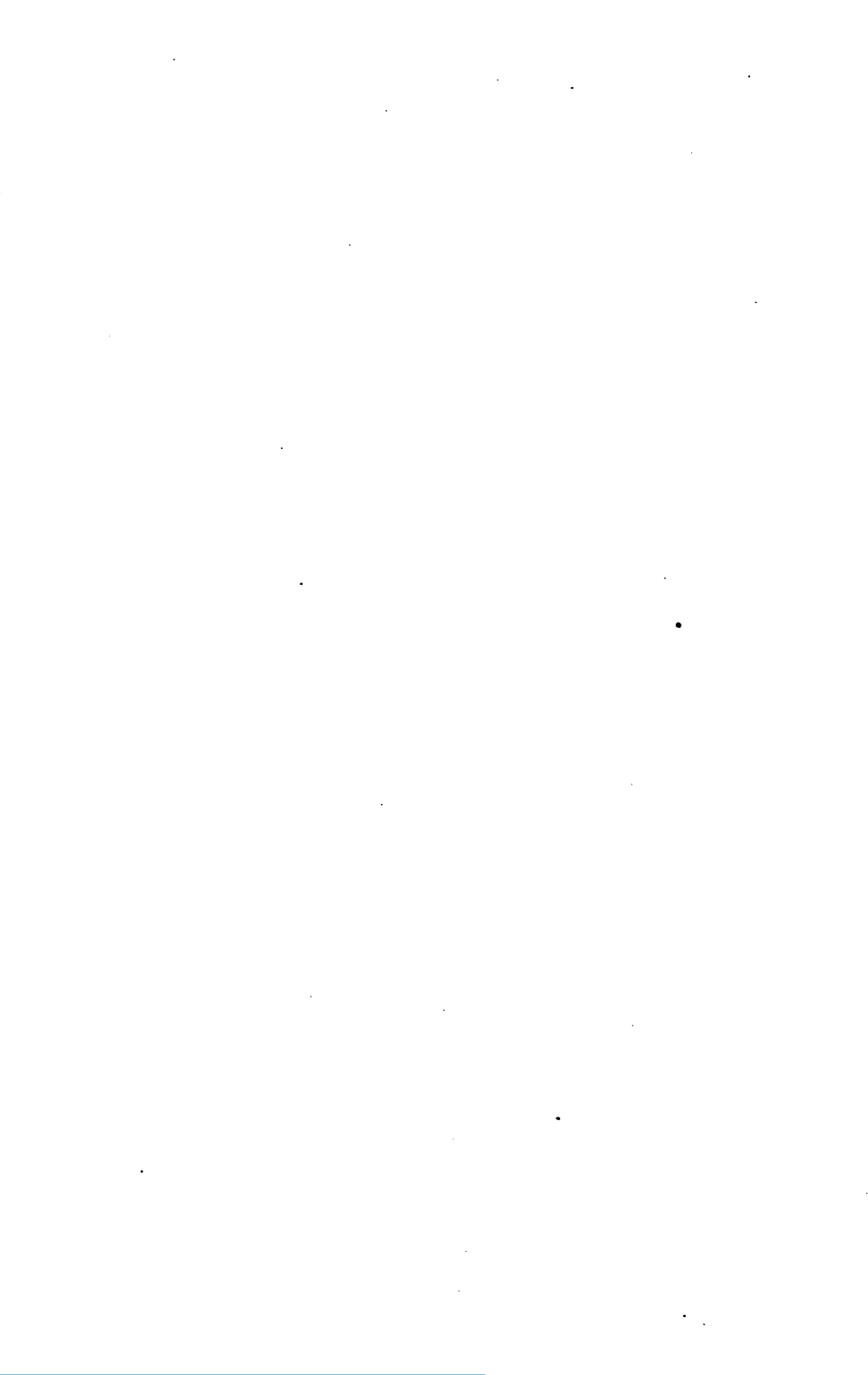

FIG. 39.—Cost of power per hour for electric pumping plants at a flat rate of \$50 per horsepower per year.

beyond which, if the cost rises, it shows an error in design or operation.



## IRRIGATION IN KLAMATH COUNTY, OREG.

By F. L. KENT,

*Assistant Agriculturist, Oregon Agricultural College.*

The nature of the work in Klamath County, Oreg., during the summer of 1904 may be briefly summarized as follows:

Determination of losses by seepage and evaporation on Adams ditches, the Ankeny, and the Mitchell lateral; the duty of water on 38.5-acre tract and a 5-acre tract owned by N. S. Merrill, a 40-acre tract and a 95-acre tract owned by William Ball, a 118-acre tract by free flooding and a 110-acre tract by checks, both owned by Ankeny and Cantrell; comparison of labor required in different methods of irrigating; determination of evaporation from Adams ditch for one month; collection of samples of soil and irrigation waters for analysis; collection of data relative to alfalfa growing, and photographing irrigation works and haymaking appliances.

Irrigation has been practiced in Klamath County for a considerable time, the property of the Klamath Falls Irrigation Company, commonly known as the Ankeny ditch, having been built in 1884, and that of the Little Klamath Ditch Company, locally known as the Adams ditch, having been built in 1885. Each of these systems has been enlarged to more than twice its original water-carrying capacity.

The first-named system is now supplying water to about 4,000 acres, but could easily be enlarged to cover about 10,000 acres, which area of land lies within easy reach. Under this system water is sold on the basis of \$2.50 per California miner's inch, each user taking about 1 inch for every 2 acres. The water supply is taken directly from Klamath Lake and distributed along about 16 miles of main ditch.

The Little Klamath Ditch Company (Adams ditch) takes its water supply from Little Klamath Lake by a channel recently cut through about 4 miles of tule growth discharging into White Lake, thence through a deep cut of about 1 mile into the Lost River Valley. Here two branches about 8 miles in length supply about 5,000 acres on the south side of Lost River, while the greater portion of the water passing through the cut is flumed across Lost River and distributed by means of two main ditches of about 32 miles total length to about 8,000 acres. Under this system water is delivered to users at the rate of \$1.50 per acre for the season.



That portion of the water which is not flumed across Lost River belongs to a stock organization known as Van Brimmer Ditch Company, which operates about as follows: There are about 5,000 acres under the ditch, each acre of which represents one share. On May 1, 1903, when the ditch property was purchased from Van Brimmer Brothers, the originators of the system, the sum of \$5 per share was paid in for the purchase of the property. The cost of maintenance is to be assessed pro rata per share, and it is estimated that this item will amount to less than 25 cents per share annually, which assumption is warranted by the results of the past two growing seasons.

On Sprague River the canals of the North Fork Irrigating Company and the Sprague River Irrigation Company, each cover about 2,000 acres. These ditches are about 12 and 11 miles long, respectively, including the principal laterals. They are both stock concerns, the shares being held by the water users.

On Wood River prairie, which lies to the northward of Klamath Lake, some 3,000 to 4,000 acres are irrigated from the mountain streams fed by the snows of Crater Lake Mountain (Mount Mazama) and other high mountains. Here, as on Sprague River, the water is very cold (54° F. observed at 2 p. m., July 7) and is used mainly for the irrigation of wild grasses. It is doubtful if simpler irrigation engineering problems can be found anywhere than those of the Wood River prairie. The whole area slopes uniformly toward the south with a fall of 3 to 5 feet per mile. Wood River and smaller streams have such very low banks that the water may be diverted at almost any point. The uniformity of the surface, and the ease with which the soil is worked, make it possible, as reported, with three horses on a plow and six on a road machine to construct between 4 and 5 miles of "surface ditch" in a day. And the system of applying the water is quite as simple. As one user expressed it, "there is no system; water is simply led out on the higher lands and allowed to flood those of a slightly lower level. The water is generally turned on to wild meadows about June 1 and left on from four to six weeks."

Under the Ankeny and Lost River systems, the principal crop grown is alfalfa, although wheat, oats, and barley are largely grown. Alfalfa yields 4 to 5 tons of hay per acre per season, there being two cuttings. Wheat yields, per acre, 20 to 30 bushels; oats, 30 to 50 bushels, and barley, 40 to 60 bushels. Two and sometimes three irrigations per season are applied to alfalfa, the first about May 15, and the second about July 15. Grain usually gets but one irrigation, and that about June 15 to 30. Irrigators estimate that about the same amount of water is applied at each irrigation.

In addition to the systems already mentioned considerable irrigation is done with the water of springs. The Griffith and Bord water wheels on Lost River each furnish sufficient water to irrigate 250 acres,

and Mr. F. J. Bowne, of Bonanza, upper Lost River Valley, has this year (1904) installed a steam pumping plant designed to supply water for the irrigation of about 1,800 acres.

Some idea of the climatology of the region may be gained from the Weather Bureau reports, as furnished by voluntary observer Marion Hanks, near Klamath Falls, and given in the following table:

*Precipitation near Klamath Falls, Oreg.*

Year.	Jan.	Feb.	Mar.	Apr.	May.	June.	July.	Aug.	Sept.	Oct.	Nov.	Dec.	Total.
	<i>In.</i>	<i>In.</i>	<i>In.</i>	<i>In.</i>	<i>In.</i>	<i>In.</i>	<i>In.</i>	<i>In.</i>	<i>In.</i>	<i>In.</i>	<i>In.</i>	<i>In.</i>	<i>In.</i>
1901.....	5.30	1.85	0.50	1.17	0.50	0	Trace.	Trace.	1.63	0.90	1.29	2.29	
1902.....	Trace.	2.50	0.50	1.17	0.50	0	Trace.	Trace.	0	0.85	1.29	2.29	11.26
1903.....	3.90	Trace.	1.18	.20		1.93	0					1.36	
1904.....	1.00	4.60	3.62		.45	.75							

*Monthly temperature averages, Klamath Falls, Oreg.*

Year.	Jan.	Feb.	Mar.	Apr.	May.	June.	July.	Aug.	Sept.	Oct.	Nov.	Dec.	Total.
	<i>°F.</i>	<i>°F.</i>	<i>°F.</i>	<i>°F.</i>	<i>°F.</i>	<i>°F.</i>	<i>°F.</i>	<i>°F.</i>	<i>°F.</i>	<i>°F.</i>	<i>°F.</i>	<i>°F.</i>	<i>°F.</i>
1901.....	25.2	31.3	37.6	43.7	54.8	57.2	68.1	70	54.6	51.9	40.8	32.6	47.3
1902.....	30.2	37.8	38.6	45.2	52.8	60.7	63.2	68.3	64	47.4	38.4	33.3	48.3
1903.....	31.6	26.8	37.8	46.8		63.4	65.1					33.8	
1904.....	27.2	30.8	35.3	47.2	58	59							

In the Wood River region the average temperature is somewhat lower and the precipitation somewhat greater than near Klamath Falls, while in the Lost River region the average temperature is higher and the annual precipitation rather less. The Sprague River section very closely resembles the Wood River region as to temperature and precipitation. The whole area is above an elevation of 4,200 feet, consequently summer frosts are quite liable to occur.

The work discussed below was carried on during the months of July and August. A very unusual rainfall during the first ten days of the month of July interfered with the work, as the Ankeny ditch was injured to such an extent that it supplied no water to users for more than a week. An unusual amount of spring rain delayed plant growth and threw the irrigation periods considerably later than usual. In fact the July rains furnished so much water that several growers deemed it unnecessary to irrigate their grain crops, hence it is probable that the duty of water, as indicated by these investigations, is higher than would ordinarily be the case.

**LOSSES FROM ADAMS DITCHES.**

The seepage and evaporation losses from the Adams ditches were measured July 15 and 16, 1904. The old ditch has a fall of 1.8 feet per mile and the new ditch a fall of 0.7 foot per mile. The results of the measurements are given in the following table.

*Losses from Adams ditches.*

[In cubic feet per second.]

## OLD DITCH.

Discharge 600 feet below Lost River flume .....	16.99
Diversions .....	1.37
Discharge 6 miles below upper measurement .....	13.89
	<hr/>
	15.26
Loss in 6 miles .....	1.73
Percentage of loss .....	10.24

## NEW DITCH.

Discharge 300 feet below Lost River flume .....	18.16
Discharge 8 miles below .....	15.88
	<hr/>
Loss in 8 miles .....	2.28
Percentage of loss .....	12.55

**LOSSES FROM ANKENY DITCH.**

The losses from the Ankeny ditch were measured twice during the season. The ditch was built on a grade of 1 foot per mile. For the first mile the ditch follows a very rocky and, in places, steep hillside, where much of the loss doubtless occurs. August 9 the velocities were measured by the use of floats and August 20 by the use of a current meter. The results of these measurements are as follows:

*Losses from Ankeny ditch.*

[In cubic feet per second.]

## AUGUST 9.

Discharge 200 feet below power plant .....	43.98
Diversions .....	2.00
Discharge 6.5 miles below upper station .....	36.38
	<hr/>
	38.38
Loss in 6.5 miles .....	5.60
Percentage of loss .....	12.73

## AUGUST 20.

Discharge 200 feet below power plant .....	43.41
Discharge 6.5 miles below upper station .....	35.57
	<hr/>
Loss in 6.5 miles .....	7.84
Percentage of loss .....	18.06

**LOSSES FROM MITCHELL LATERAL.**

The losses from the Mitchell lateral of the Ankeny ditch were measured August 9. For a large part of the distance between the points of measurement this lateral was overgrown with sweet clover, alfalfa, etc., while in other places occasional gopher holes allowed considerable water to escape. It doubtless represented as unfavorable

conditions as would be found on any of the laterals of the Ankeny system. The results are as follows:

*Losses from Mitchell lateral.*

[In cubic feet per second.]

Discharge one-half mile below head gate.....	3.92
Discharge 1½ miles below upper station.....	3.12
Loss in 1½ miles.....	.80
Percentage of loss.....	20

### DUTY OF WATER.

The field work of 1904 was limited to the months of July and August, and therefore it was not possible to secure complete records of the water used during the season. The plan followed was to determine the quantity used in a single irrigation and from this estimate the quantity used during the season.

#### N. S. MERRILL'S 38.5-ACRE TRACT OF ALFALFA.

This field was irrigated July 24-28. The water was measured over a Cipolletti weir and the depths recorded by an automatic register. The total amount was 20.09 acre-feet, giving an average depth over the 38.5 acres of 6.27 inches. In the opinion of Mr. Merrill, who applied the water, this was about the usual quantity he has been in the habit of applying at each of the two irrigations annually given this field. The check system was used, this being the method usually followed among the water users in the Lost River Valley.

#### N. S. MERRILL'S 5-ACRE TRACT OF ALFALFA.

This field was irrigated July 28-30. The water was measured over the same weir used in the preceding measurement. At one point the water broke over the check levee and a considerable amount ran on to other lands, and there was fully 6 inches of water in parts of some of the checks twenty-four hours after the water was turned off. The results are, therefore, considerably higher than would normally be obtained. The measurements show that 8.77 acre-feet of water was used, giving an average depth of 1.75 feet.

#### WILLIAM BALL'S 40-ACRE TRACT OF ALFALFA.

This field was irrigated July 17-21. Owing to the delay in getting water into the main ditch this field did not receive irrigation which it should have had about the middle of June and had received no water prior to this time. The field received 29.29 acre-feet, giving a depth of 8.78 inches.

**WILLIAM BALL'S 95-ACRE TRACT OF ALFALFA.**

This field was irrigated July 23-27. It had received the usual irrigation in June. The field received water from two laterals, the total amount supplied to the two being 47.83 acre-feet, giving a depth of 6.05 inches.

**ANKENY & CANTRELL'S 118-ACRE TRACT OF ALFALFA.**

This field was irrigated August 8-11. The water was applied by free flooding and was supplied by two laterals. The total amount received was 48.46 acre-feet, giving a depth of 4.92 inches. The comparatively small quantity necessary to irrigate this field was due to the large head used and to the fact that the alfalfa had made considerable growth since cutting, thus lessening evaporation. However, some of the high spots received no water, and it is probable that the irrigation was not quite heavy enough.

**ANKENY & CANTRELL'S 110-ACRE TRACT OF ALFALFA.**

This field was irrigated August 14-18. It received 54.2 acre-feet, giving a depth of 5.92 inches. The water was applied by the check system.

These two fields belonging to Ankeny & Cantrell furnish data for comparison of the cost of irrigating by the check system and by free flooding. Applying the water by free flooding required two men and a team for one day; and plowing furrows and otherwise preparing ditches for the distribution of water, the services of two men for five days were required to apply the water, and the days were very long. Allowing \$2.50 per day for each man and \$2 for the team, the cost of spreading the water on the 118 acres amounts to \$32, or about 27 cents per acre. In applying water by the check system practically no preparation was required before turning on the water, and one man working five days was easily able to attend to the handling of the water for 110 acres. Taking the same wages as before, the cost would amount to \$12.50, or a little more than 11 cents per acre. This does not take into account the cost of checking the land, which depends to a considerable extent on the slope. Mr. N. S. Merrill, who is a firm believer in the check system, estimates that his checking has cost him about \$10 per acre, but he has some land upon which the check levees are not more than 1 rod apart with a fall of 1 foot between checks.

Mr. J. F. Adams, who has superintended a large amount of check construction, says that one man with a "Buck scraper" and a 4-horse team can construct about one-fourth mile of checks per day for a 3-inch fall, and such a working outfit is worth about \$5 per day. On this basis, using as an example the 80-acre field of Mr. M. E. Robinson, a sketch of which accompanies this report (fig. 40), the cost of construct-

ing the check levees would amount to about \$60. The cost of locating the levees would probably amount to \$20 additional, making the cost of putting in the checks about \$80, or about \$1 per acre in this particular case. This is an ideal field for the application of the checking system, although there are other checked fields of equal area in the Lost River system which have a less amount of levee work. To the above estimate should be added the cost of putting in twenty gates, two for each levee, although in many cases canvas, manure, or dirt dams are used in the laterals instead of gates. The manure or dirt dams are not to be recommended, as they require too much labor.

A peculiar feature of the practice of water users under the Adams and the Ankeny ditches is their attitude toward the use or nonuse of the checking system. Ankeny & Cantrell are practically the only users of checks under the Ankeny ditch, and they propose to decrease

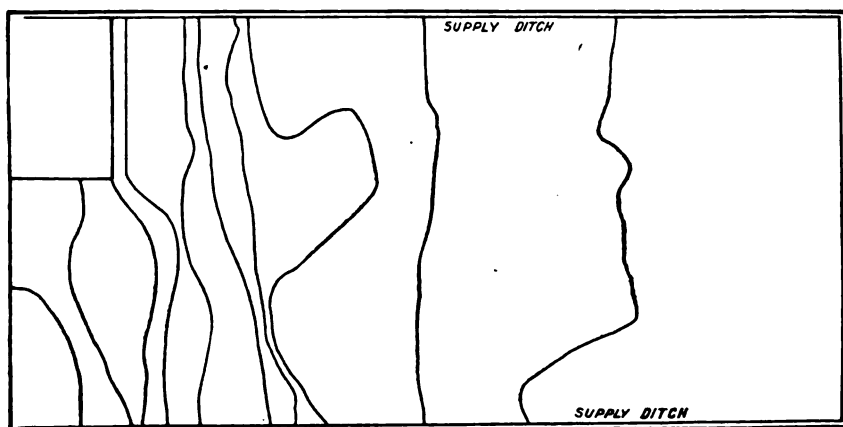

FIG. 40.—Plan of farm of M. E. Robinson, showing contour levees.

and perhaps eliminate their checked area, while practically all of the users under the Adams ditch follow the check method. The lands covered by these two ditches approach within less than 10 miles of each other, and to a close observer there appears to be no particular difference in the character of the soils, except perhaps the presence of a little more sand and a trifle less clay in the region served by the Adams ditch.

### EVAPORATION.

In the absence of a regular evaporation pan, a pan 13 by 9 inches and 9 inches deep, inclosed in a wooden framework suitable for properly floating the pan, was placed in the Adams ditch on July 24 and filled to a depth of 7 inches. The evaporation by seven-day periods was as follows: First period, 2.5 inches; second period, 3.125 inches; third period, 2.5 inches; fourth period, 2 inches; next three days, 0.875 inch. Total for thirty-one days beginning July 24, 11 inches.

## ANALYSES OF SOIL AND WATER.

## SOILS.

The samples of soil were taken to determine the effect upon the soil of the continued growing of alfalfa irrigated from the waters of the Adams ditch. The claim had been set up that the waters of this ditch carried a considerable amount of organic matter by reason of the water slowly passing through a considerable area of tule growth before reaching the ditch; hence its use would tend to build up the land irrigated therefrom. Sample A was taken from virgin soil which had never been irrigated. Sample B was taken from a field which had been growing alfalfa continuously for nine years, having grown just one grain crop prior to being seeded to alfalfa. The samples were taken about 150 feet apart and represented apparently exactly the same original soil conditions.

The results of the analyses are as follows:

*Analysis of soil irrigated by Adams ditch.*

[Determinations made by F. E. Edwards, Oregon Agricultural College.]

Constituent.	Sample A	Sample B
	(virgin soil).	(nine years in alfalfa).
	<i>Per cent.</i>	<i>Per cent.</i>
Potash (K <sub>2</sub> O) .....	0.43	0.41
Lime (CaO) .....	1.56	.98
Magnesia (MgO) .....	.11	.05
Phosphoric acid (P <sub>2</sub> O <sub>5</sub> ) .....	.09	.085
Nitrogen .....	1.66	.177

These analyses would seem to show that the soil is built up by growing alfalfa under the irrigated conditions already described, but whether the increase in the nitrogen content is due to the character of the irrigation waters or to the growing of the alfalfa on the land is not determinable in this case.

## IRRIGATION WATER.

The waters of Lost River, which are used at the F. J. Bowne pumping plant, come from a large number of springs. An analysis of this water with reference to its use both for boiler and irrigation purposes gave the following:

*Analysis of waters of Lost River, Oregon.*

[Determination by A. L. Knisely, Oregon Experiment Station.]

Constituent.	Parts per million.	Grains per gallon.	Constituent.	Parts per million.	Grains per gallon.
NaCl .....	5.3	0.31	CaCO <sub>3</sub> .....	77.5	4.56
NaSO <sub>4</sub> .....	11	.64	Fe <sub>2</sub> O <sub>3</sub> .....	5.2	.30
Na <sub>2</sub> CO <sub>3</sub> .....	1	.06	Al <sub>2</sub> O <sub>3</sub> .....	22.9	2.24
K <sub>2</sub> CO <sub>3</sub> .....	3.7	.22	SiO <sub>2</sub> .....		
MgCO <sub>3</sub> .....	93	5.43			

The following analyses, made by A. L. Knisely and F. E. Edwards, of the Oregon Experiment Station, give an idea of the composition of the irrigating waters furnished by the Ankeny and Adams ditches:

*Analysis of waters from Ankeny and Adams ditches.*

Constituent.	Parts per million.				
	1. Little Klamath Lake.	2. Adams.	3. Ankeny.	4. Adams.	5. Ankeny.
Total solids (110° C.) .....	307	467	128	369.6	174.4
Organic matter.....	76	93		80	60
Silica (SiO <sub>2</sub> ).....	34	16	37	45	40
Sodium chloride (NaCl).....	50.9	75.4	50.9	23	11.5
Sodium carbonate (Na <sub>2</sub> CO <sub>3</sub> ).....	56.8	137.8	25	148.4	31.8
Sodium sulphate (Na <sub>2</sub> SO <sub>4</sub> ).....				35.5	42.5
Calcium carbonate (CaCO <sub>3</sub> ).....	125	107.5		38	85.2
Magnesium carbonate (MgCO <sub>3</sub> ).....		21.7		63.4	
Nitrogen (N).....	8.4	9.3	6.2		
Iron and alumina (Fe <sub>2</sub> O <sub>3</sub> +Al <sub>2</sub> O <sub>3</sub> ).....			50		2.9

For grains per gallon use the divisor 17.12.

Nos. 1, 2, and 3 are from samples taken in 1903, and 4 and 5 from samples taken in 1904. Nos. 2 and 4 were taken at practically the same points and seasons of the year, namely, about August 1, at which time the ditches were carrying an average quantity of water, and the same may be said of Nos. 3 and 5. No. 1 was taken for the purpose of determining whether any considerable change took place in the composition of the water used by the Adams ditch by reason of passing through the tule growth and White Lake. The results seem to indicate an increase in both organic matter and soluble salts, particularly sodium and magnesium carbonates.

**PRACTICE IN ALFALFA GROWING.**

Several growers were interviewed under each of the two systems previously referred to, the results indicating that there was no essential difference in the methods followed under the two systems. In the matter of preparing the ground, it is the practice to grow grain for two or more years after clearing away the sagebrush before sowing to alfalfa. The seeding is uniformly done with a press drill, and as a rule no "nurse crop" is used. When such a crop is sown, barley seems to be preferred. Eight to 10 pounds of seed per acre is the amount usually sown, although one grower recommended 20 pounds, and another regarded 6 pounds, or even less, as being sufficient if it can be evenly applied.

The time for seeding has quite a range, some preferring to sow early in April. Others consider June 1 to 15 as the proper season. One of the oldest and most successful growers says he has had excellent results from sowing during the latter part of February. If the seed is sown early, that is, prior to May 15, it will not as a rule require irrigation



to start a vigorous growth. Two irrigations are usually given the fields, but there is a growing sentiment in favor of three applications of water, and it is the opinion of the writer that the latter practice will soon become general. With three irrigations they would come about four weeks apart, beginning usually about May 15.

The first cutting usually takes place about July 1 and yields 2 to 2.5 tons of hay per acre. The second cutting usually takes place about September 15 and yields 1.5 to 2 tons per acre. From four to six weeks' fall pasture is usually obtained after the removal of the second cutting. The renewal of an alfalfa field is usually recommended after seven to nine years of growth, although some well-cared-for fields seemed to be in prime condition at twelve to fourteen years of age. Treatment similar to that given new land is recommended before reseeding to alfalfa.

In the opinion of some of the most successful growers, more damage is done by the use of too much water and imperfect drainage than from the use of too little water. Especially is this true under the checking system. It certainly does not take an experienced eye to see that there is much waste of water under each of the ditch systems which have been discussed.

# IRRIGATION INVESTIGATIONS IN YAKIMA VALLEY, WASHINGTON, 1904.

By O. L. WALLER,

*Irrigation Engineer, Washington Agricultural Experiment Station.*

In the Yakima Valley there are thousands of acres of land along the rivers, bottom lands or river bars, composed of such materials as a very rapid stream would deposit, principally coarse gravel with very little soil over the surface. Such lands under present methods of spreading require very large quantities of water at a wetting and very frequent wettings. In some instances 1 cubic foot per second is used on 10 acres, and rarely does a second-foot serve more than 30 acres. These lands are supplied from small private ditches that in most instances have been in use many years. They were the first appropriations from the stream, taken when water was abundant. The supply being so plentiful, there was no need of careful distribution. The drainage through the underlying gravel being perfect, there was no fear of alkali, and slovenly methods of spreading have always obtained.

The writer has in mind one instance where the land was so stony it could not be plowed, no attempt was made to level, the sagebrush was grubbed, the seed was scattered broadcast, and the water run over as best it could be. When seen the farmer was cutting a fair crop of alfalfa hay.

Under other conditions these wasteful methods would not only damage the lands themselves, but would materially shorten the water supply. On these river-bar farms, however, no damage is done; on the other hand, these great, deep gravel bars act as a reservoir to hold back enormous quantities of water used early in the season. The canals heading farther down are beneficiaries, since this stored water returns slowly to the streams and keeps up the supply during months when there is a shortage. This would largely compensate if the same methods were not continued through the months of short supply. During these months they really waste water enough from the already scant supply to water three or four times the area of all the lands so wastefully served. This of course limits the reclaimed acreage lower down the valleys. If the water could be carefully and economically used on these gravelly lands from July on, they might materially aid in the solution of storage problems.

The seepage waters from the irrigated lands under the Indian canals and from the Sunnyside lands from the middle of July on, supply the major part of the water used for power and irrigation at Prosser.

Measurements taken the latter part of August showed something over 20 per cent as much water returning to the Yakima River from Union Gap to Prosser as was used at that time for irrigation between the two points. This return water for the future will likely be all that will be required for irrigation and power purposes at Prosser.

### SEEPAGE.

Some seepage measurements on Sunnyside laterals show surprisingly small losses. Observations on 25,060 feet of Snipes Mountain lateral, an extremely well-silted channel, carrying 63 cubic feet per second showed only one-fourth of 1 per cent per 1,000 feet, or 1 per cent of the amount carried for every 4,000 feet. The velocity in this lateral is slow and the sediment precipitated is mostly very fine sand and silt. The water always runs muddy.

Three-fourths of a mile of the Sunnyside Supply, a lateral carrying 9.25 second feet, showed too small a loss to be worth considering. The upper end of this lateral was well scoured, deep down into the hardpan, the water ran muddy, and nearly the whole stretch was lined with fine silt.

Of the South Branch, a lateral carrying 16.51 second feet, 1.29 miles showed a loss of only 1 per cent in the entire distance, and this loss was due largely to evaporation. The gradient was extremely flat, the channel wide, the water much spread out over side berms and silt bars. The water ran muddy; silt was deposited in profusion. The gaugings were made about noon with the mercury 103° F. in the shade.

### COST OF PREPARING LAND FOR IRRIGATION.

The cost of preparing land for irrigation in the Yakima and Natches valleys is dependent on the strength of the sagebrush growth, the character of the soil, the work of the wind, evenness and slope of the surface, relative proportion of ditch and flume, checks and drops and other timber structures. As these conditions vary greatly throughout the valley there must be quite a wide difference in expense accounts.

Through personal interviews and correspondence considerable data, based on actual experience, were secured. Some are given below.

We cleared 340 acres of sagebrush in the Kittitas Valley and put it in grain last spring. We used very heavy double-gang plows, each drawn by six large mules, putting the plows right into the sagebrush. We set the plows to turn a very deep furrow, thus getting well down on the roots of the sage and giving the plow such a firm grip that the heaviest sage would not cause it to jump or dodge. The plows cut the sage cleanly and on the large brush raised and threw them to one side rather than covered them. This work we had done under contract at \$3 per acre, 5 acres

being an average day's work. It cost us \$1.50 per acre to pick and burn the brush, and 75 cents per acre to harrow and drill in the grain.

We experimented with walking plows and found that they would not work at all, as they could not be kept in the ground; we also tried very heavy single-riding plows, but found that they did not take grip enough to prevent their dodging sideways when they encountered heavily rooted clumps of sage. The heavy gang plow will cleanly remove any sage that it is possible to get the motive power through or over. We found the mules much preferable to horses, as they were steadier, easily clambered through, around, and over the sage, and did not skin their legs like horses.

The sage was the ordinary sagebrush of this locality, in some places quite dense and heavy, often shoulder high, in other places it was small and scattering with a thick growth of white or yellow sage. We did not grub except here and there a clump of unusually large brush that it would have been impossible for mules to climb over or straddle. (By straddle I mean the dodging of the brush by a mule going on either side of it.) We found by plowing very deeply that the plows stood up to the brush much better, did not dodge or jump, and more effectively removed them. The plows did not clog to any extent. The brush was bent over by the frame of the plow, and when the roots were cut by the plowshare they sort of kicked themselves free and rolled out on top of the ground. We afterwards picked them by hand and burned them. The total expense of grubbing by hand on the entire tract was \$14. Certainly the gang plow is the cheapest and best device for clearing sagebrush land.

The land was fairly smooth and was not blown into hummocks. It settled very evenly and was not graded after first watering. The wind did not trouble us in the least at any time; it never does in Kittitas County. It sometimes caused a little bother in haying, making stacking a little troublesome, but does not interfere with seeding in any way. The water caused no trouble and washed no gullies.

The land cleared was SW.  $\frac{1}{4}$ , sec. 19, T. 17 N., R. 20 E.; the W.  $\frac{1}{2}$  of NW.  $\frac{1}{4}$ , sec. 30, and the W.  $\frac{1}{4}$  of E.  $\frac{1}{2}$ , sec. 30, same township and range.

J. E. Frost.

ELLENSBURG, WASH., December 6.

I can not give the information so much in detail as you would probably like. The cost per acre of improving my land in the lower Sunnyside Valley (NE.  $\frac{1}{4}$  NW.  $\frac{1}{4}$ , sec. 11, T. N., R. 23 E., W. M.) was as follows:

*Cost per acre of preparing land for irrigation.*

Clearing and burning brush.....	\$5.00
Leveling, building head ditches, seeding and watering first time.	15.00
Seed, 16 pounds of alfalfa, at 15 cents per pound.....	2.40
3 pecks of wheat, at 60 cents per bushel.....	.45
Lumber for head ditch, checks, and lath for spouts.....	2.00
<b>Total</b> .....	<b>24.85</b>

The wheat and alfalfa for first year paid cost of irrigation, about \$1.50 per acre.

The cost of building flumes, if irrigation is from flumes only, would be about \$4 to \$5 per acre for good, substantial flumes laid on the ground. Head ditches, counting labor of building, checks, spouts, etc., would be somewhat cheaper, about \$2 to \$3.50 per acre, but they are more expensive to maintain and operate.

These figures are for rough, sandy soil, with a good slope. Flat, sandy land would cost more to level. Smooth, rolling land would cost less.

The brush was what we would call heavy, the larger being 3 to 5 feet high and 3 to 6 inches through at the ground; probably 6 to 10 clumps to the square rod. The brush was first railed by dragging a 12-foot length of 60-pound railroad iron

across and back over the same strip in opposite directions, thus forcing the brush both ways. This required four strong horses. As the soil was rather sandy volcanic ash, this effectually loosened and pulled up three-fourths of the brush. The loosened brush was then raked into windrows by a brush rake. The process left everything flattened and easy of attack with the grubbing hoe.

This land was gently rolling, with some few wind-formed hummocks from 1 to 2 feet high around the sagebrush, which were almost entirely leveled by the raking. This land was carefully graded the first time and required no additional work after the first watering. It sloped so gently that the water did not wash or cut deep gullies. The soil is a light, sandy loam about 60 feet deep with occasional streaks of hardpan.

ROSS K. TIFFANY,

*Chief Engineer, Washington Irrigation Company.*

Mr. J. T. Brownfield reported as follows on 20 acres near Prosser (NE.  $\frac{1}{4}$ , NE.  $\frac{1}{4}$ , sec. 4, T. 25, R. E., W. M.):

Grubbing and burning was contracted at \$2.50 per acre. The balance of the work by myself.

Plowing, ten days with 2 horses.

Harrowing, three times, five or six days.

Leveling, ten or eleven days with a scraper and straightedge, using four horses.

Planting, 4 acres of potatoes, one and one-half days, 32 sacks of potatoes, \$20; 3 acres of onions, two days with planter, \$3 for seed; 2 acres of pumpkins, two hours with hoe, 2 pounds of seed, \$2; 5 acres of grain, wheat, and oats, 10 bushels of seed, \$12, one-half day to sow and harrow, 2 acres not in; 4 acres of corn, carrots, beans, parsnips, tomatoes, etc., seed, \$5, and one day required to plant, using hoe and planter. Ditches for watering are included in the above estimate.

We use a railroad rail to loosen sagebrush and think it the best. Some, however, use plowshare steel drawn out sharp and bolted to a heavy piece of timber. This gives weight enough to pull up the brush. The field is then raked, grubbed, and raked again. The most satisfactory tool for collecting the brush is a rake with heavy iron teeth, mounted on wheels and operated by a lever like the common self-dump hay rake. It takes from 4 to 6 horses to pull one of these, but they do the work thoroughly.

This land was about an average of the country, neither hilly nor rough; some draws to fill and some knolls to take off. The soil is too heavy to blow into drifts; consequently it was easily leveled.

This land was planted to hoed crops so that it might be regraded at the end of the season and before finally seeding to grass. To protect the land from washouts and gullies considerable care must be exercised when water is first applied and until the ground is thoroughly settled.

The soil here is a heavy gray or black loam with gravel under and big boulders on top and bed rock under the gravel at 3 to 7 feet deep. There is more or less alkali in places which comes to the top and forms a white crust, but the drainage is good and will help to get the alkali out of the ground.

Neil Campbell, on 80 acres of alfalfa near Wapato, E.  $\frac{1}{2}$  of NW.  $\frac{1}{4}$  and W.  $\frac{1}{2}$  of W.  $\frac{1}{4}$ , sec. 28, T. 11, R. 19, reports \$13.50 per acre for all expense, exclusive of laterals, head ditches, and furrowing.

The sagebrush on same would average from 2 to 3 $\frac{1}{2}$  feet high and would average about 3 feet apart. To loosen it he used a heavy piece of timber faced on ground side with an 8-inch piece of steel beveled on the edge; that is, the piece of steel would have about the same bevel

as a wood chisel. Holes were drilled through this, through which  $\frac{1}{2}$ -inch bolts were inserted to hold it to the timber, which should be 10 to 12 feet long and 16 inches square. To this four horses are hitched. It is dragged over the sagebrush and back, loosening and breaking most of the clumps. The rake consists of a piece of timber 12 feet long and 8 inches square, with 2-inch holes bored through about 12 inches apart; into these are put oak teeth, and shafts or long handles are attached. These are placed over the hind gear of a wagon between standards. The rake is then chained to the wagon. One man drives and another holds the shafts of the rake, and when he wishes to clean the rake of brush he bears down on the shafts, lifting the rake clear above the brush, leaving it in windrows or piles; after this fires are started, which are followed by the plow, and what sage is left, which will be considerable, is grubbed out and picked by hand. This was not hilly land, but had numerous little hummocks. For getting same in shape for irrigating a steel scraper was used which required four horses to operate. This moves dirt rapidly. One man can operate it and with a little experience can make a nice, even grade for irrigating. The land was graded and seeded to alfalfa before water was applied. One inexperienced in grading should water and regrade after first irrigating and before seeding to secure an even surface.

The land here slopes so gently that the water can be applied by the furrow system without danger of washing or cutting gullies. The soil is clay liberally mixed with gravel.

Mr. H. J. Postma, in the Moxee Valley, furnishes the following itemized list of labor expended in preparing the land and planting 20 acres of potatoes (this land is the E.  $\frac{1}{4}$  of NE.  $\frac{1}{4}$  of the SE.  $\frac{1}{4}$ ; sec. 36, T. 13 N., R. 19):

Two days railing, 2 men and 6 horses; two days raking, 1 man and 2 horses; after railing it was grubbed, eight days grubbing, 1 man; 4 days burning; plowing, twelve days, 1 man and 3 horses; one day harrowing on 6 acres, 2 horses, 1 harrow; leveling, four days for 1 man with 3 horses, two days for 1 man with 4 horses; planting, six days for 1 man and 2 horses; ditching, six days for 1 man and 1 horse; seed, 13,500 pounds of potatoes, at \$6 per ton, \$40.50; 300 lath tubes and a little flume, \$18.

The sagebrush on this land averaged about 2 feet high, but was thickly distributed over the land. The land was cleared by using a 16-foot railroad rail bolted to a piece of timber so that the edge of the rail stood like a scraper. Bolted to this timber and extending back for 2 men to stand on were 2 planks. Six horses pulled this machine over the sage and back, pulling up much of it and breaking down some. The work was done in the spring when the ground was moist. After this the brush was raked into windrows and burned. The land was comparatively even, showing but few wind hummocks. There

were a few draws where the filled earth settled considerably, but potatoes were planted on these so that the land could be regraded before seeding.

The soil is a rather heavy sandy loam underlaid with hardpan which in places comes quite close to the surface. This hardpan softens by watering and is freely penetrated by alfalfa roots.

Mr. Jones A. Aves, near Wapato, put in 20 acres by his own labor during the spring of 1904. He estimated the cost of grubbing and plowing at \$3.50 per acre, or \$87.50; leveling, \$1 per acre, \$25. The sagebrush on this land averaged 3 to 4 feet high and pretty well covered the ground. It was easily grubbed when the ground was wet. The young and willowy brush was plowed out, but the ranker growth was grubbed. The big, coarse brush lifted the doubletrees and forced the plow out of the ground. It is best first to use a breaker, consisting of two railroad rails 12 feet long bolted together. This, hauled over and back, will break off and pull up most of the brush, after which the plow will usually complete the work. Before plowing, however, the loosened brush must be raked and burned. When the grubbing hoe is entirely relied upon, one-half to three-fourths of an acre is a day's work for 1 man.

The soil is from 1 to 4 feet deep and is underlaid with gravel, is of a yellowish-brown color, and very easy to work. The surface being quite even very little leveling was required. This farm was on the Yakima Indian Reservation, which has only a gentle slope, so that the water rarely washes out gullies. The subsoil being coarse gravel, large quantities of water were required the first season or until the ground was well settled.

Arthur Belliveau reports the following expenses incurred in clearing 40 acres and planting it to potatoes in the Moxee Valley:

*Cost of clearing 40 acres and planting potatoes.*

Grubbing, raking, and burning sagebrush, at \$2.50 per acre .....	\$100
Plowing, at \$2 per acre .....	80
Four days' scraping with 2 teams and 2 men, at \$6 per day .....	24
Leveling, 1 man and 2 teams, eight days, at \$5 .....	40
Planting, sixteen days, 3 men and 1 team, at \$5 .....	80
Seed, 17 tons, at \$6 per ton .....	102
Ditching, eight days, 1 man and 1 horse, at \$2 .....	16
	442

Average cost per acre, \$11.05.

Mr. John Michels on 340 acres of reservation land reports a cost of \$31.50 per acre for improvements. One hundred and eighty acres of this was seeded to alfalfa at a cost of \$40 to \$45 per acre. Cost of grubbing and burning was \$2.50 per acre and plowing \$2 per acre.

**DUTY OF WATER.**

That group of ditches diverting water from creeks the flow of which is either all covered by decrees or else the entire flow used, was reported last year and consequently will be omitted from this year's investigations. The lands covered by this group amount to about 41,000 acres cultivated and some 24,000 acres under ditch but uncultivated, and will remain covered with sagebrush until more economical methods in the use of water shall release some of that now wastefully applied, to be used on these fertile and valuable lands.

A very considerable part of the water used on these lands is covered by court decrees, and in most instances the decrees protect an extensive and wasteful use so out of proportion to the needs of the land that in some instances through the rise of alkali they have become worthless except as reclaimed by expensive drainage.

The following tables show the result of measurements made in 1904. In some cases continuous records were kept and in others single measurements were made:

*Ditches in Kittitas County.*

	Acres irrigated.	Depth applied.						Discharge.	
		May.	June.	July.	Aug.	Sept.	Total.	Date.	Dis-charge.
		Inches.	Inches.	Inches.	Inches.	Inches.	Inches.		Cu. ft. per sec.
<b>Yakima River:</b>									
Bull Ditch Co.....	1,200							July 13	27.7
Cascade Canal Co.....								Aug. 8	27
Ellensburg Water Co.....	7,500								
Ellison & Bruton.....	205								
Andrew Oleson.....	800								
West Side Irrigation Co.....	5,000	0.25	4.75	6				Aug. 9	21.5
<b>Peanneway River:</b>									
H. H. Knight.....	170							Aug. 12	8.27
Masterson ditch.....	390							July 14	4.25
Tomas ditch.....	125							do	1.70
J. S. Dysart.....	275							do	1.40
Heider & Peterson.....	175								
Goodwin & Mosher.....	185								
William Krueger.....	25								
Contratti.....	50								
Gabrial Gandolph.....	15								
John Granslina.....	75								
Frank Amosso.....	80								
Banka & Contratti.....	40								
Costa & Caldryn.....	30								
Cosetti Brothers.....	40								
West Fork.....	150								
East Fork.....	185								
Swauk River.....	230								
<b>Tanum Creek: Tanum Ditch Co.....</b>	<b>3,360</b>							July 13	17.6
	20,305								



*Ditches heading in the Natches River.*

	Acres irrigated.	Depth applied.						Discharge.	
		May.	June.	July.	Aug.	Sept.	Total.	Date.	Discharge.
		Inches.	Inches.	Inches.	Inches.	Inches.	Inches.		<i>Cu. ft. per sec.</i>
Northwestern Water and Light Co.....	92								
Natches and Cowitche.....	2,044	12.5	11.25	11.75	13.50	6.71	55.5		
Union ditch.....	2,800	21	25	24.5					
City ditch.....									
Old Schanno.....									
New Schanno.....	900	16.5	14.75	17	18.25		66.5		
Broadgagne.....									
Fruitvale.....	340								
Yakima Valley Irrigation Co.	3,600	8.75	10	9.2		12.55	51		
Basketfort Ditch Co.....	277							Aug. 25	5.9
Schules & Rodenback (upper).....	60							Aug. 26	3.7
Schules & Rodenback (lower).....	60								
Scott Ditch Co.....	153							Aug. 25	8.1
The Powell Ditch Co.....	249							do	10
The Fortune Ditch Co.....	201							do	12.7
John Foster.....	40							do	1.7
Foster Natches Irrigation Co.	42								
Natches Valley Irrigation Co. a.....	1,612	21.5	33.5	23.75	22.5	30.5	126		
Leach & White.....	125								
Long & McCormick.....	160							June 30	1.2
Morrissy.....	145							do	3.7
Friend & Jacobson.....	31								
Chapman & Shearer.....	54							June 30	2.1
Friend & Jacobson.....	90								
Nelson & Jacobson.....	90							June 30	8.6
The Kelley ditch.....	385							do	5.9
The Denton & Lowrey.....	197								
The Clark ditch.....	274								
Wapato.....	1,700	14.5	13.25	14.25	14.75	11.5	68.5		
Selah Valley Co.....	5,500	4½	9	7.5	10	9	40		
D. A. Ball.....	85								
W. S. Carmack.....	120								
Harry Griffen.....	40								
W. S. Stevens.....	40							Aug. 20	4.2
Frederick & Beck.....	60							do	5.7
James Beck.....	50							do	3.9
James Markel.....	175								
George Johnson.....	15								
Z. H. Benton.....	40								
R. S. and C.....	300	7.75	7.5	7.75	7.5	38.25	68.8		
From Big Rattlesnake Creek:									
McDaniels, Williams & Abel.....	245							Aug. 20	5
Mile Creek: Abel, Johnson & McDaniels.....	130							do	1.2

a April, 4.25 inches.

Canals heading in the Yakima River in Yakima County.

	Acres irrigated.	Depth applied.						Discharge.	
		May.	June.	July.	Aug.	Sept.	Total.	Date.	Discharge.
		Inches.	Inches.	Inches.	Inches.	Inches.	Inches.		Cu. ft. per sec.
Selah & Moxee .....	5,500	9.00	9.25	9.75	9.75	9.00	46.50		
Taylor .....	1,775			9.00					
Fowler .....	1,250	7.75	12.75	14.00	13.50	18.00	66.00		
Granger .....	100								
Hubbard .....	3,000	3.12	7.12	10.75	8.75	7.00	40.00		
Moxee .....									
New Reservation .....	1,400	7.50	19.25	37.25	26.50	39.75	129.50		
Old Reservation .....	4,943	9.50	17.75	17.75					
Toppenish ditch .....	1,080								
Gilbert .....	2,500	17.00	15.75	15.13	11.00			July 6	19.10
Perry Cleman .....	640								
McDonald .....	580								
Bright & Hutton .....	120							July 6	2.70
Read .....	100								
Freeman .....	115								
Moody & Pardin .....	128								
Henry Beddoe .....	70								
Milner .....	150								
Jellison & Heaton .....	180								
P. Queen .....	170								
J. L. Craib .....	420								
Kirkwood, Bebee, Bailey, Bakey, Martin & Milton .....	425								
Hatch ditch .....	600							July 6	11.20
Sunnyside canal .....	32,000	11.60	12.30	10.70	12.30	11.30	73.00		
Prosser Falls Land and Irrigation Co. ....	1,300	6.84	7.10	7.57	6.90	5.10	47.69		
N. P. Irrigation Co., Kiona .....									
N. P. Irrigation Co., Kennewide .....	3,500	19.00	18.75	17.75	18.25		98.50		

<sup>a</sup>March, 0.49; April, 5.74; October, 8.5.    <sup>b</sup>April, 4.84; October, 7.16; November, 2.18.    <sup>c</sup>April 7.

The Toppenish, Hatch, Kirkwood, P. Queen, J. L. Craib, and Freeman ditches are all on the Yakima Indian Reservation and cover lands that have been under cultivation for some time and should require hardly as much water as the Gilbert. The soil is fairly deep and is partly supplied by subirrigation.

The Perry Cleman, McDonald, and Bright & Hutton ditches, supplied from a slough, are also on the Yakima Indian Reservation, but cover new lands. The first two named get very little water after August 1; the Bright & Hutton get none after July 15. The soil under these ditches is 3 to 4 feet deep and is underlain with gravel.

The Beddoe, Milner, Moody, Pardin, Read, Jellum, and Heaton ditches extend from Wapato down the river 4 or 5 miles. The reservation lands supplied by these ditches have 3 to 4 feet of soil and a gravel subsoil, are very low, scarcely rising above high water, and on account of the coarse gravel subsoil must be affected by the high waters in June and July.

The ditches receiving water from the Naches River cover low bottom lands, old river bars, with little or no soil above and a deep gravel subsoil. These lands use the maximum amount of water and always will until better methods of distribution come into use. The ditches

are dug in the gravel, and as the waters of the Natches are exceptionally clear, no silt is precipitated. After flowing long distances in such rivers it is distributed into laterals, head ditches, and long furrows of the same kind of materials. With the limited force in the field it was impossible to measure all the water carried by these ditches during the season, but one or more measurements of most of them were made and a careful estimate of the acreage secured. The ditches and canals referred to are named as follows: Fruitvale, Old Schanno, Schuler and Rodenbach, John Foster, Foster Natches, Broadgage, Basketfort, Scott Ditch Company, Powell Ditch Company, Fortune Ditch Company, Leach & White, Long & McCormick, Morrissy, D. A. Ball, W. S. Carmack, James Beck, James Markel, George Johnson, Friend & Jacobson, Chapman & Shearer, Nelson & Jacobson, Harry Griffen, W. S. Stevens, Frederick & Beck, Z. H. Benton.

The excessive use of water and lack of drainage in the Natches Valley is shown particularly on the north side by a small waste creek near Shearers. This creek carries the waste waters from a number of canals supplying lands on higher benches and slopes. When measured in July it was discharging 14 cubic feet per second, and was sufficient to successfully irrigate 1,400 acres of land.

The upper Schuler & Rodenback, the Denton & Lowery, and the Clark ditches water land on the first bench. The soil under these ditches is from 4 or 5 to 20 feet deep, and should not require large quantities of water. However, the drainage is good and the large amounts used seem to do little damage. The above lands generally are conditioned about the same as those under the Wapato, on the opposite side of the river.

The soil under the ditches heading in the Yakima River, in Kittitas County, is much the same. It is heavier than much of that in Yakima County, is all underlain with gravel, and under present methods of distribution requires very large quantities of water. The water is carried in open ditches and distributed through furrows, in many instances as much as 20 to 30 feet apart, requiring a large and long watering to thoroughly wet between the furrows.

About Ellensburg more water is used than by the West Side Irrigation Company, on the opposite side of the river. The soil under much of the West Side canal is deeper.

The Ellensburg Water Company and the Bull ditch cover very stony lands throughout most of their courses. Marshy and alkali lands, however, are slowly telling the story of overwatering.

Mr. R. P. Tjossem, under the Bull ditch, has already reclaimed a 72-acre tract of black alkali land by deep underdrains. He commenced work as an experiment, but its marked success has called the attention of his neighbors; whose lands must soon be drained or abandoned. Only the lands underlain with hardpan seem to be affected. Wherever

there is a deep gravel subsoil with an absence of hardpan the under-drainage is good.

The lands under the ditches heading in the Teannaway are pretty well watered by heavy snows, and consequently require less irrigation than those at lower levels farther down the Yakima River. The soil is deeper than about Ellensburg. Timothy hay is the leading crop.

Single gaugings were made on the Knight, Masterson, Thomas, and Dysart ditches July 14, 1904, showing an average duty of 1 cubic foot per second to 62 acres. Such a duty for the middle of July would point to a very high mean duty for the irrigation season.

The ditches gauged cover about 43 per cent of the lands receiving water from the Teannaway, and the quantity used may fairly be taken as a mean for the entire valley.

The Taylor, Fowler, Granger, Hubbard, and Moxee canals take water from the Yakima River above North Yakima and supply low-lying lands. Some of the lands under the Taylor ditch are subirrigated. The depth to water in the wells is considerably affected as the irrigation advances, and in some instances the water becomes brackish. Under this ditch the water is distributed by flooding. Two irrigations are generally considered enough for a crop. This is an old ditch, appropriates 2,100 inches of water, uses no measuring device, and every man takes and uses to the limit of his desires. The gaugings from July 1 to August 17 show a duty of 80 acres per cubic foot per second.

All except the Taylor are on the east bank of the river and irrigate lands in the Moxee Valley immediately east of North Yakima.

The damaging effects of overwatering, or possibly it would be better to say lack of drainage, are frequently seen in this valley. Here the soil is underlaid with hardpan along which the surplus water from the upper levels follow and ultimately comes to the surface, depositing black alkali. The 80-acre hopyard of Mr. Hiscock was in the line of this seepage and very much damaged. He put in extensive under-drains and has been very handsomely paid for the undertaking from the increased profits. On August 1, 1904, the outlet drain from the yard discharged 3.7 second-feet, at least enough to irrigate 370 acres of land.

Results under the Washington Irrigation Company's canal, the Sunnyside, show very marked improvement.

In 1900 they used no measuring boxes. Since that time practically every service has to be supplied with a Cipolletti weir, and during the season of 1904 the company employed a man to keep the weirs in order and to see that the farmers made proper use of the water supplied and that waste was cut off. From the old régime of using and wasting all the water they wanted to the present one of plenty but none to waste, the company has met and overcome many difficulties, but through all

of it there has been rigid fairness. The results of 1904 show commendable progress, at least when it is remembered that the 75-acre duty secured for the season is based on measurements made at the intake and that the water was distributed through 50 miles of main canal and about 300 miles of laterals.

Of the canals irrigating bench lands, where the soil may be considered deep and where the conditions correspond fairly well to those under the Sunnyside, only those of the Yakima Valley Irrigation Company and the Selah Valley Company secured a higher duty, and in both instances the supply canals were much shorter and the system of laterals much less extended.

The water duties in Washington have been extremely low and that on the low gravel bars is yet, but the uplands show marked improvements. Men are studying conditions; are anxious to protect their own lands from expensive drainage enterprises and alkali deposits. While many men believe that the more water the more grass is a true saying, they are wondering how many years their lands will stand that kind of abuse and still raise grass. The alkali wastes along the Ahtanum and a few similar spots well distributed throughout the Yakima Valley stand as reminders of what was once the finest grass fields in the State but now covered with salt grass, greasewood, and ponds of water. For many years men did not know the cause of such desolation and financial loss. They were even slow to believe that the raising of the water table had anything to do with it, but people have been reading the best literature on irrigation, have been observing, and are becoming more careful in the use of water.

# IRRIGATION CONDITIONS IN RAFT RIVER WATER DISTRICT, IDAHO, 1904.

By WILLIAM FRANCIS BARTLETT,  
*Agent and Expert.*

## **CONDITIONS WHICH GOVERN THE CONTROL AND DIVISION OF WATER.**

The drainage area of Raft River and its tributaries is comparatively small, comprising all told 410,000 acres. From the standpoint of size and the area reclaimed by its waters Raft River has relatively little importance in the irrigable area of Idaho. From the standpoint of problems involved in the control and distribution of its waters, probably no stream in Idaho presents more serious complications. If the difficulties met with were purely physical, it would be a simple matter to overcome them. In diverting water from Raft River and its tributaries no very difficult engineering obstacles need be encountered. However, few water users have had the benefit of engineering advice or assistance in laying out their ditches, which are in poor condition, due in most cases to an excessive grade. But the condition of ditches has been a minor factor in the control and distribution of water.

Raft River water district of water division No. 2, State of Idaho, includes Raft River and its tributaries between a line running east and west through the center of township 13 south and the Idaho-Utah State line, and between ranges 22 and 28 east of Boise meridian.

### **TRIBUTARIES TO RAFT RIVER.**

The South Fork of Raft River rises in Utah among the Raft River Mountains, 15 miles south of the State line. The North Fork rises in Idaho on the eastern slope of the Goose Creek Mountains and flows south into Utah, where it meets the South Fork. The junction of these streams forms the main river, which flows north over the State line through a canyon, and for 6 miles farther flows through a narrow valley skirting the southeastern border of Almo Valley. The river then turns abruptly east and again enters a narrow strip of land hemmed in on both sides by lava hills and high mesas to emerge 6 miles farther on into Raft River Valley, through which it takes a direct northerly course, emptying into the Snake River 45 miles by section lines north of the Idaho-Utah State line. Raft River Valley

varies in width from 2 to 15 miles, between the Black Pine Mountains lying to the east and high lava hills rising in the west. No tributaries flow from these hills to Raft River except little torrents in the early spring. The river receives its entire supply from the drainage of the mountains along the southern border of the State and the Goose Creek Range, in which Almo Creek has its source. Almo Creek is to-day the most important, and in fact the all-important, tributary to Raft River in the Raft River district. From Goose Creek Mountains it takes a generally easterly course and 15 miles from its head empties into Raft River about 5 miles north of the Idaho-Utah State line.

Four other streams that at one time were tributaries to Raft River rise on the northern slope of the Raft River Mountains in Utah and flowing north empty or at one time did empty into Raft River in Idaho, anywhere from 4 to 10 miles north of the State line. These streams are Clear, Six Mile, One Mile, and George creeks, the waters of which are usually all used for irrigation before reaching the main channel of the river.

The rights to water from Raft River and its tributary, Almo Creek, were adjudicated in 1893 in the district court for Cassia County. This decree has proved anything but satisfactory. This is mainly due to the provision in the decree for a measuring device. The wording of the decree is as follows: "Each appropriator, under and by virtue of this decree, is hereby required to build and maintain a box at the head of his ditch  $16\frac{1}{2}$  feet long with three-eighths of an inch fall to the rod, with a head gate so arranged as to take the amount of water to which he is entitled under this decree." How was a man who never measured water in his life to know how to "so arrange his head gate as to take the amount of water to which he is entitled under this decree"? How wide and how deep should his box " $16\frac{1}{2}$  feet long with a three-eighths of an inch fall to the rod" be in order "to take the amount to which he is entitled under this decree"? Unless the water user is familiar with the use of Kutter's formula in figuring out proper cross sections he is as much at a loss to know how to measure the exact amount of water diverted from the stream as he was before the decree was rendered. It is needless to say that Kutter's formula is not a household word on Raft River.

The order of the court, after describing such a box for measuring water, further states: "And every person is prohibited and enjoined from taking any water from said river or its tributaries at any time except through such a box and as authorized by this decree." The result has been that although the water users were not learned in hydraulic formulas or accustomed to their application, they were ready to take every advantage of a decree such as the above and put in boxes  $16\frac{1}{2}$  feet long with a three-eighths inch fall to the rod of any depth and width they chose and so arranged their head gates as to take almost

any quantity of water they wished. Who was to say whether they were taking too much or too little, since they complied with the order of the court to the letter, so far as they understood it, and the water master knew no better how to measure water than the water user diverting it? This particular paragraph in the decree of the court has been the great stumbling block which has delayed the inaugurating of a proper system for the measurement and distribution of water for Raft River and Almo Creek. To-day many of the water users insist upon the box measurement as prescribed in the decree and refuse to put in weirs. The water master can only endeavor to persuade the water user to place a standard weir in his ditch; he can not compel the adoption of the weir as a measuring device, for there is the decree always held up before him and no statute nor direction of water master or water commissioner or State engineer has availed to overcome its defects. The result of this state of affairs has been that water masters have assumed an arbitrary way of guessing at the volume of water each user was entitled to and allowing the appropriator to take only that volume. The fact that both the water master and the water user were conscious that neither could measure water accurately was a constant source of friction, especially during the lower stages of the river, when the water became scarcer each day and more necessary to the farmer. Charges of gross favoritism against the water master and countercharges of theft of water against the water user were of daily occurrence.

#### **THE MANNER IN WHICH THE DUTIES OF THE WATER MASTER ARE AFFECTED BY THE NATURE OF WATER TITLES AND THE STATE IRRIGATION LAWS.**

Such was the condition of affairs when the irrigation law of 1903 took effect. The passage of this law could in no way affect the decreed priorities on any stream in the State, but the provisions of the bill for dividing the State into three water divisions (sec. 13) and for the appointment of a water commissioner for each water division (sec. 17) have been a long step forward in helping to solve the many complex questions arising on both decreed and undecreed streams. These provisions are important, since through them the services of a man may be secured whose duty it is to establish administrative measures according to law for the proper control of the water districts under his charge.

#### **PROVISIONS FOR WATER COMMISSIONERS AND WATER MASTERS.**

The water commissioners are appointed by the governor, with the consent of the senate. The law provides that one of the water commissioners first appointed shall hold office for a period of six years,



one for four years, and one for two years, but that after the expiration of the first terms each commissioner appointed shall hold office for six years, or until his successor shall have qualified.

Such water commissioner shall possess such theoretical knowledge of the science of hydraulics as will enable him to supervise the construction of such measuring devices as may be necessary to place in any ditch, canal, or stream for the proper measurement of water. He shall be acquainted with the streams of his district and shall be capable of instructing the water master who may be placed in charge of such streams in all matters in relation to the distribution of the water of such streams in accordance with the priorities of the rights of those using such waters.

The water commissioner must give bond in the sum of \$5,000.

The water masters for the water districts within a division are appointed by the water commissioner of that division. Each water master holds office for one year; or until his successor is appointed, and may be removed for failure to perform his duty as water master upon complaint made to the water commissioner in writing. He must give bond in penal sum of \$500.

#### **DIFFICULTIES ENCOUNTERED IN INSTALLING MEASURING DEVICES.**

The first water master appointed on Raft River by the water commissioner after this new law went into effect had had no training or experience in hydraulics. He was, however, a conscientious worker and endeavored to the best of his ability to divide the water in an equitable way. As an experiment, he placed several weirs in different ditches along Almo Creek, with the consent of the water users. Unfortunately, these so-called weirs in no case met the conditions necessary for a measuring device. When in the season of 1904 a proper weir was set to meet the conditions necessary to make the weir an accurate measuring device, the water master of that season was told he did not know his business, and was threatened in every way for placing in the canal a weir with the correct dimensions. When it came to measuring the water over the new weir the difference in discharge between the two measuring devices was so marked that vigorous objection was made by the water users, and after the weir was set it was pried up with crowbars and the water allowed to run under the weir board. The penalty for this offense under the new law is a fine not to exceed \$100, or imprisonment in the county jail not to exceed six months, or both fine and imprisonment.

As it was the desire of the State engineer and the water commissioner to help the water users to understand the new rulings and requirements and to straighten out the difficulties met with with as little friction as possible, it was thought best not to prosecute the offenders. The new State irrigation law was still on trial. Much opposition to its operation in various districts was shown, and, in order to spare it from open political antagonism, as was threatened in

some sections of the Raft River water district, the water master's attitude had often to be more conciliatory than he personally deemed best.

#### **DEFECTS OF THE PRESENT LAW AS APPLYING TO THIS DISTRICT.**

The weakest point in the new law encountered by the water master on Raft River in the season of 1904 was the same as the weakness of the old law, and is found in section 31, which reads as follows:

SEC. 31. The appropriator of any of the public waters of the State shall maintain, to the satisfaction of the water commissioner of the district in which such appropriation is made, a substantial head gate at the point where the water is diverted, which shall be of such construction that it can be locked and kept closed by the water master or other officer in charge; and such appropriator shall construct and maintain, when required by the water commissioner, a rating flume or other measuring device as near the head of such ditch as is practicable, for the purpose of assisting the water master in determining the amount that may be diverted into said ditch from the stream. Plans for such rating flumes or other measuring devices shall be furnished by the State engineer. It shall also be the duty of those taking water from a stream whose waters have been allotted to place at suitable intervals on said stream, under the direction of the water commissioner of the division in which such stream is situated, suitable measuring devices, so that the flow of such stream may be properly measured. If any user or appropriator of public waters that may or may not have been allotted should neglect or refuse to put in such head gates or measuring devices as will provide for the proper distribution of said water according to the rights of the several parties entitled to the use thereof, after ten days' notice to do so by the water commissioner, it shall be the duty of said commissioner to put in such head gates, flumes, or measuring devices at the expense of the county where the expense is incurred, and said water commissioner shall make up a sworn statement of the cost of such head gates, flumes, or measuring devices, which shall be presented to the board of county commissioners at their first regular meeting after the performance of such work, and said county commissioners shall present a bill of costs to the owners of said ditch or ditches: *Provided*, That if the owner of any such ditch shall refuse or neglect for ten days after the presentation of such bill of costs to pay the same, or any other charge made against such ditch or owner thereof under the provisions of this act, the water commissioner shall order the head gate of such ditch closed and locked until such charge or charges shall be paid.

The weakest point in this section is embodied in the clause which makes it obligatory upon the water commissioner to put in head gates, flumes, or measuring devices, should the user or appropriator neglect or refuse to do so after ten days' notice, and to present the bill of costs to the board of county commissioners, who in turn present the bill of costs to the owner of the ditch or ditches in which the head gate, flume, or measuring device has been placed by the water commissioner, with the provision—

That if the owner of any such ditch shall refuse or neglect for ten days after the presentation by the county commissioners of such bill of costs to pay the same, or any other charge made against such ditch or the owner thereof under the provisions of this act, the water commissioner shall order the head gate of such ditch closed and locked, and such head gate shall remain closed and locked until such charge or charges shall be paid.

The water commissioner of water division No. 2 has a large number of water districts in his division. It can be readily understood that he has hundreds of ditches in these new districts which need head gates and proper measuring devices. To impose upon him personally the carrying of these bills for lumber and other materials necessary for the construction of head gates and measuring devices and the cost of labor for their construction and installation is out of all reason. He would have to be an incipient millionaire to bear the first expense and would have, besides, to run the risk of having his bill disapproved for some unforeseen reason by the board of county commissioners, after perhaps carrying the bill for three months before that body meets to pass upon it.

The intent of this section of the law is obvious. It was meant to enable the water commissioner to enforce the law in regard to putting head gates and measuring devices in ditches by depriving refractory persons of the use of water until such head gates and devices were provided. But this penalty can not be imposed until the bill for the cost of material and labor has been passed upon and approved by the board of county commissioners, and they in turn present the bill to the owner of the ditch in question, who still has ten days of grace to pay the bill after presentation. The whole process could easily involve three months' time in the Raft River water district, almost the length of the irrigation season.

A water master hardly feels justified in incurring bills of this nature at the expense of the water commissioner or himself, for in sparsely populated districts like Raft River labor is not always easy to obtain, and in most cases for both material and labor cash must be paid. But neither the water commissioner nor water master has authority to draw upon the funds at the disposal of the county commissioners, except through the customary process of presenting a sworn statement of expenses incurred, at the regular meeting of the board, which, in Cassia County, is at the end of every quarter, or three months.

The water master of the Raft River water district for the irrigation season of 1904 was an agent of the irrigation and drainage investigations of the United States Department of Agriculture, who undertook the charge through the request of the State engineer and the water commissioner of division No. 2. He was versed in hydraulics and accustomed to the use of the current meter for measuring the discharge of streams and ditches and used one the entire season to properly regulate the distribution of water. Only a few of the water users on Almo Creek questioned the accuracy of measurements made with the current meter, but they were the men who questioned every measuring device and preferred to trust to their own guess at the amount of water flowing in streams and ditches rather than depend upon recognized standard measuring devices.

**WATER TITLES.**

The decreed rights to water from Raft River and Almo Creek range in dates from 1871 to 1887. The total amount of water decreed from these streams is 142.34 cubic feet per second, or 7,117 miner's inches. This is divided among thirty individuals. The largest total appropriation is by the Keogh Brothers, or the Raft River Land and Cattle Company, of 44.9 cubic feet per second, or 2,245 miner's inches, the dates of their priorities ranging from 1871, the date of the oldest right on the river, to 1883, one of the later rights.

The next largest right under the decree is that of the Durham Land and Cattle Company, which is entitled to 22.22 cubic feet per second, or 1,111 miner's inches, with rights dating from 1872 to 1884.

Eleven other rights decreed to water users on Raft River proper amount to 2,001 miner's inches or 40.02 cubic feet per second; the largest individual right equals 536 miner's inches and the smallest 40. Two rights included in these eleven, comprising 330 miner's inches, have been abandoned.

The decreed rights from Almo Creek include a total of 35.60 cubic feet per second, or 1,760 miner's inches, divided into various-sized allotments among sixteen different parties to the decree, the largest individual amount being 200 inches and the smallest 50 inches, the dates of priority ranging from 1878 to 1885.

**ATTITUDE OF THE IRRIGATORS.**

On assuming the duties of water master in Raft River water district for the season of 1904, after having been duly called to such duty on April 15 by a signed petition from two water users on Raft River, the water master's introduction to the water users of his district was in the form of a threat of an injunction from the water users of Almo Creek, restraining him from exercising any jurisdiction over that particular section of the Raft River water district.

Almo Creek, as has been said, is the principal tributary to Raft River in this district, and under the terms of the decree is recognized as a tributary until June 15 of each year. According to the judgment rendered by Judge Lyttleton Price in the Raft River contempt case, "the water flowing in Almo Creek up to that time each year is Raft River water and is intended to be dealt with and awarded and distributed as such." Judge Price also says:

From the commencement of irrigation each year to June 15, priorities of right must be recognized and enforced between all parties to the decree, those resident on Raft River and on Almo Creek alike in all respects. After June 15 each year priorities of right on Almo Creek are to be recognized and enforced as between residents on Almo Creek only, regardless and irrespective of the dates of the rights of residents on Raft River.

The decree of the district court is explicit, but the water users of Almo Creek wished to have the Raft River decree reopened and Almo Creek set aside as a separate and distinct water district for the entire irrigating season of each year instead of from June 15 each year as the decree specifies. They thought that to serve an injunction on the Raft River water master restraining him from exercising jurisdiction over the stream would be the first step in legal proceedings. On April 19 the water master was informed that an injunction would be served against him within a few days and that he might as well not waste his time inspecting that section of the district. However, the water master was obliged to follow out the orders of the court specified in the decree and instructed the representative of the Almo Water Company to put in a proper measuring device at the head of their canal; and those who divert water directly from Almo Creek were also instructed to put in measuring devices, the Cipolletti weir being suggested as the best one. The water users, having been advised by lawyers not to recognize in any way the authority of the Raft River water master, refused at that time to heed any instructions from him.

The earliest rights on Raft River are held by Mr. J. M. Pierce and the Keogh Brothers. Their farms are adjacent and are situated at the lower end of the Raft River district. The Pierce ranch has a water right for 10.72 cubic feet per second, or 536 miner's inches, dated from 1871. The Keogh Brothers hold rights for 10.1 cubic feet per second, or 505 inches, dating from 1871; 16 cubic feet per second, or 800 inches, dating from 1879; 2.4 cubic feet per second, or 120 inches, dating from 1881; 6.4 cubic feet per second, or 320 inches, dating from 1882, and 10 cubic feet per second, or 500 inches, dating from 1883—a combined quantity of 44.9 cubic feet per second, or 2,245 inches.

Lying immediately above these two large ranches are five smaller ranches. Their water rights are all of later dates—1884, 1886, and 1887. Their combined rights amount to 18.60 cubic feet per second, or 930 inches.

Above these ranches are the holdings of the Durham Land and Cattle Company, which extend for 7 miles up the river. This land is entitled to 22.22 cubic feet per second, or 1,111 inches, with priorities dating from 1872 to 1884. Above this ranch are located three small ranches, whose combined water rights amount to 4.1 cubic feet per second, or 205 inches, all dating from 1882.

It will be seen that the earliest rights are attached to land lying at the very lowest extremity of the Raft River district. The owners of these rights have naturally guarded them jealously, and friction has always existed between owners of the two larger ranches and the owners of the smaller ranches lying immediately above them.

To judge whether the river had a sufficient amount of water to fill the 1884 rights or only enough to satisfy the 1883 rights was the task

of the water master, who at best could make an approximate estimate only, as there was no measuring device in the river to gauge the amount of water flowing therein. This decision was of vital importance to the possessors of 1884 rights. With the conviction that the water users above them on the stream, both on Raft River and Almo Creek, were taking more water than they were entitled to, while the water master at times was allowing a greater supply of water than was necessary to pass their head gates to supply the rights below them without allowing them a drop, the farmers with 1884 and later rights felt that they were "between the devil and the deep sea."

On the other hand the water master was often found fault with by the larger ranch owners for not satisfying their rights before favoring the later ones. The friction caused in the division of water on the lower end of the river resulted in the farmers seeking outside advice in regard to reliable measuring devices. Weirs were placed in several ditches. One was set for the Keogh Brothers by the then State engineer, Mr. Mills. Mr. F. M. Langford, a holder of an 1884 right, who from his theoretical knowledge of hydraulics and his practical experience is the best informed man on the river in regard to the flow of water in streams and ditches, helped set two or three other weirs, and an endeavor was made to measure accurately the water on the lower end of the river. However, weirs were not placed in all ditches, and the uncertainty as to the quantity of water received by those ditches where the old measuring box was still in use was a cause of continual dissatisfaction.

In 1904 the farmers on Raft River proper showed a willingness from the start to accept the recommendations of the water master and to place in their ditches what measuring devices were necessary or to repair those that needed alteration. However, much dissatisfaction has been felt by these men because, while they are entirely willing to have the water decreed to their lands measured by the most accurate measuring devices which can be made, the Almo Creek water users still continue to have their water measured to them by guess or through useless measuring devices.

#### **STATUS OF THE ALMO WATER COMPANY.**

The Almo Water Company is composed of all the parties to the Raft River decree who derive their water supply from Almo Creek and its tributaries, with the exception of one man near the mouth of the creek who controls 140 inches of water. This company has combined all the decreed rights into one common right, irrespective of priorities. To those members of the company who are parties to the decree are given shares in the Almo Water Company on the basis of 14 shares to 200 inches of decreed water. The Almo Water Company owns 100 shares, according to a statement made by Mr. Harold King,

whose father, Mr. Thomas O. King, is a party to the Raft River decree and entitled to 180 inches of water from Almo Creek, with a priority of 1880. These shares, however, can not be sold by the company as a company, but shares can and have been sold by the shareholders of the company to farmers who have no decreed rights from Almo Creek. These farmers are outside of the Raft River decree and are entirely dependent upon the water company for their water supply. If the water company were dissolved, the farms which have been built up by men who own shares in the Almo Water Company, entitling them to a certain amount of water from the company's ditch, but who are not parties to the decree and have no legal rights to water from Almo Creek, would be left without water and ruined. As has been said, there are 16 water users on Almo Creek who are parties to the Raft River water decree and are also members of the Almo Water Company, but besides these individuals water is supplied from the Almo Canal to at least 10 other individuals who have no legal water rights.

The Almo Water Company is not an incorporated company; it has no legal standing. At the same time the members of the Almo Water Company claim their company is not subject to taxation even in the face of the law, which reads as follows:

The following property is exempt from taxation: All irrigating canals and ditches and water rights appurtenant thereto, when the owner or owners of said irrigating canals and ditches use the water thereof exclusively upon land or lands owned by him, her, or them: *Provided*, In case any water be sold or rented from any such canal or ditch, then, in that event, such canal or ditch shall be taxed to the extent of such sale or rental.

Article XV, section 1, of the constitution of Idaho reads as follows:

The use of all waters now appropriated, or that may be appropriated for sale, rental, or distribution; also of all water originally appropriated for private use, but which after such appropriation has heretofore been, or may hereafter be sold, rented, or distributed, is hereby declared to be a public use, and subject to the regulation and control of the State in the manner prescribed by law.

Section 2 of the same article reads:

The right to collect rates or compensation for the use of water supplied to any county, city, or town, or water district, or the inhabitants thereof is a franchise, and can not be exercised except by authority of and in the manner prescribed by law.

In distributing water from the Almo canal, each owner of a share or shares is given water according to the number of shares owned. Two shares may represent an "irrigating stream" for two hours; 20 shares, for twenty hours; or when the water supply is low and water becomes scarce in the canal, 2 shares may represent only the use of an "irrigating stream" for one hour, and 20 shares the use of an irrigating stream for ten hours. The water in the canal is divided, distributed, and rotated at the discretion of a committee of three members of

the water company, who hold their positions by election. The water is not measured in any regular way, but is distributed in "irrigating heads" determined by the private water master the company appoints for that purpose.

The members of the Almo Water Company claim that under the Raft River decree certain of their members are entitled to specific amounts of water from Almo Creek with various dates of priority from 1878 to 1885, and that if through methods of economical rotation of the water to which their canal company is entitled they can increase the irrigable area of their community by selling or renting the surplus water gained by the practice of rotation, that they should be and are entitled to dispose of the water decreed to members of the company in a way to obtain its highest efficiency.

The water users on Raft River who are parties to the decree and who divert water from Raft River proper have an entirely opposite opinion as to the rights of the Almo Water Company to dispose of any surplus water by renting or selling it. Their contention is that if the parties to the Raft River decree on Almo Creek can not put all their water to beneficial use upon the land to which the findings of fact made the same appurtenant, the Almo users have no right to sell the excess to be conveyed to other lands, but must turn it back into the stream and allow it to go to the next appropriator. The decree reads:

It is further considered, ordered, adjudged, and decreed that when the waters appropriated are not needed for useful and beneficial purposes, all water shall be turned into the stream and allowed to go down to the next appropriator.

The water users on Raft River proper further contend that in every case where water is sold and delivered from the Almo Water Company's canal it is conveyed farther away from Almo Creek than it would be if applied to the lands designated in the findings of fact when the decree was rendered, and that by so conveying the water of Almo Creek away from the lands adjacent to it, the appropriators below are deprived of the benefits of return seepage to the stream which they formerly enjoyed when the water of Almo Creek was applied to the lands to which it was legally made appurtenant.

### THE WATER SUPPLY.

On April 8 the water master set a gauge rod graduated to feet and tenths in Raft River under Mr. F. M. Langford's bridge, and a daily record of gauge heights was kept by Mr. Langford until June 19. Frequent measurements were made with the current meter at the bridge to determine the discharge of the river at that point for different gauge heights. This point was selected for its convenience both for keeping a record and for determining the quantities available for the holders of later priorities.



A summary of results of observation from April 8 to June 19 are given in the following table:

*Discharge of Raft River at Langford bridge.*

Date.	Average daily discharge.	Highest discharge in month.	Lowest discharge in month.	Total for month.
	<i>Cubic feet per second.</i>	<i>Cubic feet per second.</i>	<i>Cubic feet per second.</i>	<i>Acre-feet.</i>
April.....	a 75.3	112.5	38	3,432.3
May.....	98.6	142	72	6,053.2
June.....	b 72.8	112.5	38	2,738.3

a 23 days.

b 19 days.

The amount of water necessary to fill all decrees below the Langford bridge is 59.22 cubic feet per second, or 2,961 inches. The number of acres actually irrigated below this point is 2,196. Reference to the table will show the average daily discharge for April, May, and June to have been in excess of the amount necessary to fill the decrees below the bridge. But the water supply in Raft River during the irrigation season of 1904 was considered by the irrigators much in excess of the average.

On May 1 a gauge rod was set in Almo Creek near the footbridge opposite Mr. G. W. Clark's house. This point was below all diversions from Almo Creek and half a mile above the junction of Almo Creek and Raft River. Mrs. Clark very kindly kept a daily record of gauge heights from May 1 to June 25. However, owing to the fact that at high water Almo Creek overflows its banks above Mr. Clark's house and floods his fields, making temporary channels through them, the gauge heights above 2.4 feet are not to be depended upon. Having made due allowance for this condition in calculating the discharge for different gauge heights, the following table represents very closely the flow of Almo Creek at this point for the months of May and June:

*Discharge of Almo Creek below all diversions.*

Date.	Average daily discharge.	Highest discharge in month.	Lowest discharge in month.	Total for month.
	<i>Cubic feet per second.</i>	<i>Cubic feet per second.</i>	<i>Cubic feet per second.</i>	<i>Acre-feet.</i>
May.....	46	75	9	2,847
June.....	a 41	70	1	2,008

a 19 days.

Raft River above its junction with Almo Creek was measured three times during the season. On April 9 it was discharging 34 cubic feet per second; on May 31, 47 cubic feet per second; and on June 8, 32 cubic feet per second. By July 16 no water was flowing across the State line from Utah into Idaho. The flow from Reed Springs, which

comes into Raft River from the east between the State line and Almo Creek, was the main supply of Raft River after the middle of June.

On May 13 a gauge rod was set in Almo Creek above all diversions, and arrangements were made with Mr. W. E. Johnston, a possessor of one of the oldest rights on the creek, to read the gauge rod daily. Mr. Johnston read the rod daily for about one week, when the Almo Water Company ordered him to stop keeping records.

The object of keeping a daily record above all diversions on Almo Creek and below all diversions was to determine the amount of return seepage from the irrigated fields to the creek, and the information might have been of great value to the people of Almo. The measurements made below the diversions showed that not less than 35 cubic feet per second, enough to satisfy all their decrees, was passing down river up to June 15. If measurements throughout the season of the supply above all diversions had been made it would have helped to determine in a more satisfactory way the effect of irrigation along Almo Creek on the supply lower down.

**SEEPAGE.**

The following table shows the gains and losses from seepage and evaporation in 25½ miles of Raft River, from the mouth of Reed Springs to the head of the Pierce-Keogh west ditch, indicated by measurements made August 7 to 9:

*Seepage measurements on Raft River.*

Date.	No.	Station.	Distance from station 1.	Discharge at station.	Loss (-) or gain (+) per mile.
			Miles.	Cubic feet per second.	Cubic feet per second.
August 7.	1	Mouth of Reed Springs.....		2.15	
Do	2	Ford near county bridge.....	3	2.00	-0.05
Do	3	¼ mile below old Tom Gwin ranch house.....	6	2.74	+ .25
August 8.	4	100 yards below Murray bridge.....	9	2.51	- .07
Do	5	The Narrows.....	13	7.48	+1.24
Do	6	Stockade corral, Bull ranch.....	17	6.74	- .18
August 9.	7	Langford bridge.....	20	5.61	- .38
Do	8	Kirk bridge.....	23	3.38	- .74
Do	9	At head of Pierce & Keogh ditch.....	25½	2.45	- .37

In the first 10 miles the flow remained about the same. At the Narrows the amount of water in the river was found to be almost three times that at the station 4 miles above. At this point two lava hills on opposite sides of the river approach to within one-quarter of a mile of each other. Although not apparent as an outcrop, a ledge of rock beneath the surface of the bed of the river probably extends across it and forces all the water to the surface. Some farmers on the river contend that springs rising in the bed of the river at this point cause the increase in flow. If there are springs they are not perceptible.

In the 6 miles below the Narrows the river loses only 1.13 cubic feet per second, but between stations 7 and 8 it loses 2.23 cubic feet per second, and in the next  $2\frac{1}{2}$  miles loses 0.93 cubic foot per second. There were no ditches diverting water from the river during these measurements and the sky was clear. The temperature during the three days ranged between  $75^{\circ}$  and  $80^{\circ}$  F. during the hottest part of the day.

Seepage measurements were made also on the Pierce-Keogh west ditch on July 20. This ditch is  $4\frac{1}{2}$  miles long and was chosen as typical of the ditches on Raft River, none of which is in good condition. For twenty-four hours before measurements with a current meter were commenced the discharge measured at the head of the ditch over a 6-foot weir was 4.23 cubic feet per second. This was the discharge over the weir at the time gaugings were made. The first gauging was made 1 mile below the weir and the discharge at this point was found to be 4.76 cubic feet per second. The first mile of ditch was in foul condition, in some places deeply scoured, in others the flow of water was retarded by growing willows or great clots of earth which had fallen from the banks. Two miles below the weir the discharge amounted to 4.10 cubic feet per second. The bed of the section above this point consists of very sandy soil. Three miles below the weir the discharge was 3.96 cubic feet per second. The section above this point was bordered by meadow land on both sides of the ditch, the bottom of which was lined with a very soft, fine mud, averaging 0.3 of a foot in depth. The last measurement was made 4 miles below the weir, the discharge amounting to 3.52 cubic feet per second. The last section of ditch has an uneven grade. In some places it is scoured to gravel and in others the grade is so slight that sediment has collected in long stretches on the bottom of the ditch. Disregarding the measurement at the weir the total loss in 3 miles of ditch was 1.24 cubic feet per second. The greatest loss occurred in the second mile of ditch, which is built through very sandy soil. The next section, which was lined with fine mud, gave comparatively no loss. Considering the poor condition of the ditch, the loss of 1.24 cubic feet per second did not seem surprising.

#### DUTY OF WATER.

Forage crops, such as wild or native hay and alfalfa, are the principal crops irrigated from Raft River and Almo Creek. Some grain is grown, but only in small patches of from 1 to 25 acres. In Almo a little fruit and some garden truck are raised. The study of the duty of water from Almo Creek was altogether prohibited by the attitude of the irrigators. Upon Raft River two farms were chosen where accurate records could be kept of the amount of water used in the irrigation of two tracts of alfalfa. One tract comprises 31.82 acres

belonging to Mr. Langford, and the other 39.25 acres, owned by Mr. J. M. Pierce.

Mr. Langford's alfalfa field had received no water during the irrigation season, which lasts from April 1 to October 1, for two years previous to the season of 1904. His crop was a failure both years, but most of the plants lived, owing no doubt to the supply of moisture stored in the ground by the overflow of the river in the early spring, during which an adjacent field was flooded. The alfalfa plants were scattered over this field in bunches 2 or 3 feet apart. These bunches were unusually large and the stalks rather coarse.

A gauge rod was set in the ditch supplying this field, and measurements made of the discharge at the upper edge of the field. Mr. Langford kept a record of the gauge heights, reading the gauge morning and evening while water was being applied. The first irrigation the tract received in the season of 1904 was on May 29 and 30, when an average of 3.16 cubic feet per second was applied. On June 5 the next irrigation was begun, and it lasted for eight days in succession, the flow averaging 2.98 cubic feet per second. In all, 59.71 acre-feet was applied to this tract of 31.82 acres, which is the equivalent of a depth of 1.88 feet over the irrigated area. Several sharp showers of short duration fell over this field during July, and on July 5 a heavy rain storm, amounting to  $1\frac{1}{4}$  inches in ten hours, proved of additional benefit to the alfalfa.

The first crop from this field yielded 80.8 tons and the second crop 25.3 tons, the total of 106.1 tons giving an average of 3.33 tons per acre for the entire tract. The field is a rather uneven, rolling piece of ground, but special care was taken to lead the water to all parts of the tract by a sufficient number of laterals or field furrows. The soil in this tract consists of a very fine volcanic loam of great richness. Considering how comparatively thin this stand of alfalfa was, the yield proved to be large.

Mr. Pierce's alfalfa field, containing 39.25 acres, is a very level tract of an irregular shape. The main supply ditch which runs north divides at the upper extremity of the field into two streams, one skirting the western border and the other the eastern border of the field. These two ditches have been run on commanding ridges and water the tract lying between them from both directions. Mr. Pierce has laid out an excellent system of laterals in this tract, and consequently the entire area is very easily watered. A gauge rod was placed in the supply ditch above the point where it divides into two streams, and Mr. Jesse Pierce kept a record of the gauge heights at all times this tract was irrigated. Measurements were made at the gauge rod to determine the discharge at that point for different gauge heights. Irrigation of this tract was commenced June 8 and continued every day until June 30. The amount of water applied varied from 4.8

cubic feet per second to 1 cubic foot per second, the average for the twenty-three days being 2.57 cubic feet per second. The total amount applied during this period was 117 acre-feet. The next irrigation occurred July 7 and 8, and averaged 3.5 cubic feet for forty-eight hours, giving a total of 13.86 acre-feet. The third and last irrigation occurred from July 16 to 22, inclusive. The average amount applied daily during these seven days was 3.76 cubic feet per second. The total amount was 52.11 acre-feet. The total amount applied to this tract during the thirty-two days water was running was 182.96 acre-feet, an average of 4.66 acre-feet per acre.

The alfalfa in this field was three years old and of excellent quality. The first crop was cut when in three-quarters blossom and yielded 104 tons, the second crop yielded 76 tons, the total giving an average of 4.59 tons to the acre. It will be observed that this is close to being 1 acre-foot per ton per acre.

A comparison of the amount of water applied to crops upon Mr. Langford's and Mr. Pierce's fields is of interest. Mr. Langford could not have used any more water on this particular tract of alfalfa if he had wanted to. It was not to be had. He was obliged to be satisfied with one irrigation. On the other hand Mr. Pierce possessed an earlier water right and he used as much water as he deemed his crops needed. Both fields were supplied with a sufficient number of laterals to serve the crops to advantage, but the Langford field was harder to irrigate than the Pierce field on account of its contour, which has a very even, smooth surface, and so received a more uniform supply of water over its entire area. The surface soil of the Langford field is deeper and more retentive of moisture than that upon the Pierce field, which has also a very open subsoil. This in part accounts for the higher duty of water obtained by Mr. Langford.

It must be stated that Mr. Langford's success with this alfalfa field is very exceptional for Raft River. The average duty of water is low, taking Raft River as a whole. Calculating the amount of water passing the Langford bridge from April 8 to June 19, inclusive, and adding to it the various amounts used by the farmers below that point between June 19 and August 1, as given by the water master's report, the total for the season amounts to 13,185 acre-feet. This amount was applied to the cultivated area comprised in the Burrows, Oleson, Keogh, and Pierce ranches, which is estimated at 2,196 acres. This would give a duty of water of 6 acre-feet to the acre, or during the season the entire area received enough water to cover it 6 feet deep. Aside from this must be taken into account the fact that during February, Raft River overflowed its banks and submerged large areas of cultivated land, especially on the Keogh ranch, which helped wonderfully to raise the ground-water level under the whole ranch.

The showing Mr. Pierce makes is also much above the average. Probably no man on Raft River gives so much time and intelligent attention to the irrigation of his crops as Mr. Pierce. Other irrigators on the river could imitate him to advantage in supplying their fields with a sufficient number of laterals to supply water with the greatest economy to every part of the irrigated area. A great fault with most irrigators on the river is their tendency to make the water do all the work. Instead of taking time and trouble to plow a sufficient number of laterals for an efficient service of the field they attempt to force the water over too great distances, often overirrigating the upper portions of a field and not supplying enough water to the lower ends.

### INTERSTATE QUESTIONS.

Raft River is an interstate stream. The North Fork, or Junction Creek, rises in Idaho and flows into Utah. The South Fork, which is the main river, rises in Utah, as do the tributaries, George, One Mile, Six Mile, and Clear creeks. Before the settlements were established along the tributaries of Raft River the waters of these streams emptied into Raft River in Idaho. Now they seldom do. The water is generally exhausted for irrigation before it can reach the main river channel.

The claim is made by the water users on Raft River in Idaho that, with but few exceptions, all the farms in Utah along Raft River or its tributaries were located subsequent to the farms on Raft River in Idaho. The correctness of these claims will have to be determined in the courts, as will the rights to the use of water from Raft River and its tributaries, as between the irrigators in Utah and those in Idaho.

Along the South Fork are located four ranches comprising in all about 620 acres, with possibly 450 acres actually irrigated with the waters of South Fork. Three Government surveys have been made through this valley, but none has been accepted. The owners of the farms hold their land through squatters' rights. The valley of the South Fork where these ranches are located is very narrow. The farmers have taken up their land in strips of a quarter of a mile in width, including in places both sides of the creek. These fields have a pronounced slope toward the creek and are hemmed in on each side of the stream by high mesas running parallel with it. Wild hay, timothy, alfalfa, and grain are the crops grown here. The oldest ranch on the South Fork was settled in 1881, the next in 1882, and the other two in 1886. The feeling of the ranch owners is best expressed by Mr. John Lind, one of the four. He claims that the water users on South Fork had never considered the subject of prior rights on Raft River in Idaho until two years ago, when summons was served upon him and his

neighbors by the sheriff to defend themselves against a lawsuit instigated by the Keogh Brothers over the rights to the use of water from Raft River and its tributaries. The suit is still pending. Mr. Lind claims he has used the water of Raft River for twenty years without any protest from users with prior rights in Idaho, that the opportunity to protest against his using water has gone by, and that by right of constant use of water for beneficial purposes for twenty years he can not now be deprived of the use of the water nor subjected to curtailment of its use on account of prior rights in Idaho. Mr. Lind claims with others that irrigation of the narrow strips of sloping land bordering the river is a positive benefit to irrigators below, as the valley serves as a reservoir holding water back until late in the season when the seepage augments the flow of the stream when most needed. Mr. Lind further states that the farmers in Idaho do not appreciate the real reason why of late years water has become so scarce. He claims the water supply was much greater some years ago, before large bands of sheep were driven into the valley and grazed upon the surrounding hills and mountains. Before their advent the vegetation on the hills and the underbrush on the mountains held the winter snows much longer and conserved the water supply. Now the herbage is eaten away by the sheep, and sheep herders have been responsible for forest fires, and therefore the physical conditions have changed and the water pours off in great floods two months earlier in the spring than formerly. Mr. Lind thinks such physical conditions must be taken strictly into account in justly settling the present claims to the prior rights between water users of Raft River in Utah and Idaho.

George Creek is the first stream rising in Utah to enter Raft River in Idaho. This creek is bordered with farms from the mouth of the canyon from which it emerges in Utah to the State line. There are 15 farms, aggregating 2,810 acres, receiving water from George Creek. Probably half of this area is under cultivation. Water rights in this stream have never been adjudicated, although suit was brought by Mr. Yost, the earliest settler on the creek, against all other junior settlers in order to adjust his claim against them. He claimed the right to the flow of the entire creek at all seasons. The suit resulted in Mr. Yost getting a decree from the district court in Boxelder County, Utah, giving him the right to one-third of the entire flow of George Creek during the whole year. The rights to the use of any part of the remaining two-thirds of the stream were not determined. The fourteen other appropriators on the creek mutually agreed to divide the water among themselves by allotting a certain number of shares to each person. The largest number of shares held by one person is 40 and the smallest 5. All the water in the creek is rotated, Mr. Yost getting the use of the entire creek for three days out of nine. The other settlers rotate the water the remaining six days

among themselves according to a basis of shares arranged among themselves. Fifteen shares equal one-third of two-thirds of the whole stream for thirty-six hours, regardless of the amount of water in the creek.

The George Creek farmers have been made a party to the suit the Keogh Brothers brought against water users on Raft River in Utah to determine the question of prior rights on the tributaries as well as on the main river. It was claimed in the spring of 1904 by the farmers living on George Creek that their stream was no longer a tributary to Raft River and had not reached the river for seven or eight years. This may possibly have been the case up to the season of 1904, although irrigators on Raft River in Idaho dispute the statement. This season George Creek emptied considerable water into Raft River between June 1 and June 20. On June 11 six streams supplied from George Creek discharged into Raft River near each other. They were all measured with a current meter near the points where they entered the river, and the total discharge was found to amount to 16.46 cubic feet per second, or 823 inches. It can not be denied that the rights below the mouths of these streams coming from George Creek were greatly benefited by this supply at that time of the season.

Water from One Mile and Six Mile creeks did not reach Raft River during the season of 1904. These creeks are small, as their names imply, and supply water to only six small ranches bordering on the State line. It is contended that these two creeks were tributaries of Raft River before water was diverted from them for irrigation, and the settlers on these creeks have been included as defendants in the suit of the Keogh Brothers. Rotation is practiced by the users of water from these creeks. No water rights have ever been adjudicated on either stream.

Clear Creek is the largest of all the tributaries of Raft River rising in Utah. It heads in the Clear Creek Range, which is a spur of the Raft River Mountains. Its watershed lies almost altogether on the northern slope of the mountains. The snow melts gradually in the hills and high water in Clear Creek generally occurs about the middle of June, or one month later than high water in Almo Creek. Clear Creek emerges from a canyon  $1\frac{1}{2}$  miles south of the State line. The distance from the State line to the point where the creek formerly emptied into Raft River in Idaho is approximately 20 miles. Before this season only rough measurements had ever been made of the discharge of this stream. On June 6 it was measured with a current meter at the mouth of the canyon. The discharge at this point was 112.84 cubic feet per second, or 5,642 inches. Two weeks later the creek was flowing nearly 7,000 inches at this point. Four farms bordering on Clear Creek aggregate about 2,600 acres, all lying in Idaho.



The largest ranch comprises 2,000 acres, about 600 of which are under cultivation. This ranch and another comprising 160 acres are irrigated by ditches which head in Utah. Two other farms, comprising 320 acres, divert water from Clear Creek in Idaho. Besides these farms there are three small farms, comprising about 120 acres, lying in Utah between the State line and the mouth of Clear Creek Canyon.

After having considerable trouble among themselves relative to an equitable division of water from Clear Creek, the water users in Utah and Idaho made a written agreement among themselves as to how the water should be divided. This agreement was taken into the district court of Boxelder County, Utah, before Judge Hart, then presiding, and he signed the mutual agreement previously made between the different appropriators from Clear Creek. No copy of this agreement could be procured by the writer, although Mr. Louis Sweetzer, the former manager of the Sweetzer Brothers & Pierce ranch, claimed to have a copy, which he promised to lend to him. The copy was, however, mislaid. Mr. J. M. Pierce, a former joint owner of the ranch, is the authority for the statement that Sweetzer Brothers & Pierce were entitled, according to the agreement, to 600 inches of "first water," that Mr. Naff was entitled to 300 inches of "second water," and Sweetzer Brothers & Pierce were entitled to 800 inches more of "third water." Mr. Pierce could not recall the amount of any other allotment, and as none of the other water users possessed copies of the agreement, it is impossible to state what amounts they are entitled to or the basis of division, although all claim the right to an inch to the acre. This agreement was understood to govern only those rights to diversions heading in Utah whether irrigating land in Utah or Idaho. It could not apply to rights in ditches heading in Clear Creek in Idaho. Before water was diverted from it for irrigation Clear Creek was an important tributary of Raft River. It was claimed in 1904 by old settlers on Raft River that Clear Creek had not reached Raft River for a great many years. Some said fifteen years, others seven or eight. However, it is certain that not enough water from Clear Creek has reached Raft River in late years to be of any benefit to the users on the river. By the first of June this season Clear Creek had begun to rise rapidly and by June 6 was discharging 5,642 inches at the mouth of the canyon. All of this water was diverted for the ranches on Clear Creek up to June 10. After that date water commenced to flow in Clear Creek channel below Frank Burrows's ranch, the lowest on the creek, and was diverted from the channel by an old ditch to the old N. Bartholomew ranch, now owned by Mrs. Annie Oleson. The quantity of water below all diversions on Clear Creek increased during the next week to 500 inches, and what part of this was not used on the Oleson ranch was going to waste in the sagebrush. Upon examination of the bed of the old channel it was found to be obstructed by slidings

from its banks and choked by the thick growth of brush and weeds, and it was apparent that if the stream was turned down the old channel no appreciable amount of water would reach Raft River. Owing to these conditions the water master determined to turn the water into Raft River 7 miles above the mouth of its old channel. On June 22 the water master with the aid of four men dammed Clear Creek  $1\frac{1}{2}$  miles above the Oleson farm, and turned its waters into an old disused ditch and 300 feet farther on emptied into the Kirk ditch. From this point the water was carried 2 miles in the Kirk ditch to its nearest point to Raft River, just south of the Kirk house, where a ditch 100 feet long was dug and 525 inches of Clear Creek water was emptied into Raft River above the farms of Keogh Brothers & Pierce. This extra supply was of great benefit to the water users of Raft River at this time of the year, especially as Almo Creek was supplying hardly any water to Raft River.

By many of the farmers on Raft River who have been to Clear Creek during high stages of water it is contended that the users on Clear Creek turn what water they can not consume into the sagebrush to prevent its reaching Raft River. This contention seemed to be borne out by an examination of the physical conditions existing along Clear Creek during the season of 1904. There is no doubt that water from Clear Creek is wastefully used by the farmers along the stream, much to their own damage. One ditch, supplying the Sweetzer Brothers & Pierce ranch, with a measuring box supposed to be set to carry 600 inches of water was, by actual measurement, on June 6, carrying 1,271 inches. On one farm a 40-acre patch of alfalfa was being watered by five streams, none flowing less than 50 inches, and the alfalfa was then yellow from overirrigation. In the Raft River decree water is awarded to the appropriators from "Raft River and its tributaries." Although the water users on Clear Creek were not made parties to the decree at the time it was rendered, it is contended by many that the Raft River water master can exercise jurisdiction over Clear Creek in Idaho to prevent the extravagant use of water and stop its deliberate waste. Clear Creek water users contend that their stream is no longer a tributary to Raft River, and the Raft River water master has no jurisdiction over it. This is a question which will eventually have to be settled by the courts.

### CONCLUSIONS.

The first need of the Raft River water district is the installation of a uniform standard measuring device in every canal or ditch diverting water from Almo Creek or Raft River. The Cipolletti weir is the one recommended.

To insure the use of uniform measuring devices, section 31 of the irrigation law should be amended. The obvious intention of the sec-

tion is to enable the water commissioner to enforce the law relative to the construction of head gates and measuring devices in canals and ditches, but by failing to provide for the payment within reasonable time of the bills for their construction when through the refusal or neglect of the irrigators the water master has been obliged to place them himself, it leaves the burden of the expense upon the water master or water commissioner. If the water user must eventually pay for them, why should he not be made to stand the costs at once? He could be given a reasonable notification of, say, fifteen or twenty days to put in his head gate or measuring device, and then if he neglects or refuses to do so, let the law provide that he pay the cost of the head gate or measuring device installed by the water master within ten days, on penalty of being deprived of the use of water until the bill is paid.

The immediate determination of the rights of the Almo Water Company is imperative. Before the law, excess water over and above what the owners of decreed rights can put to a beneficial use belongs in the stream to be used by the next appropriator or for further appropriation. Idaho is one of the few arid States which have embodied in their laws a provision for the legal transfer of water rights. This is found in section 11, House bill 146, and reads as follows:

SEC. 11. That any person owning any land to which water has been made appurtenant either by a decree of the court or under the provisions of this act may voluntarily abandon the use of such water in whole or in part on the land which is receiving the benefit of the same, and transfer the same to other land. Such person desiring to change the place of use of such water shall first make application to the State engineer, stating fully in such application the reasons for making such transfer. Such application shall describe the land the use of the water on which is to be abandoned, and shall describe the land to which it is desired to have such right transferred, and if such water is to be conducted to such land through another canal or lateral or from a different point of diversion than the one described in the license or decree of the court confirming such right, such facts shall be fully set out in such application, and, if the State engineer shall require it, a plat showing the location of such land and ditches or canals or points of diversion shall be furnished by such applicant, and upon receipt of such application the State engineer shall examine the same and shall, provided no one shall be injured by such transfer, issue to such applicant under the seal of his office a certificate authorizing such transfer, which certificate shall state the name of the applicant and shall contain a copy of the license or an abstract of the decree confirming the right to the use of water upon the land from which it is desired to transfer such right and a description of the land to which such right is transferred. And a fee of one dollar shall be paid the State engineer by such applicant for such certificate of transfer issued by him, and such application and certificate shall be recorded by such State engineer in a book kept for that purpose, and a notice that such transfer has been authorized shall be sent by the State engineer to the water commissioner of the district in which such land is situated, and such water commissioner shall notify the water master of the stream furnishing water for the irrigation of such lands of the transfer of such use, and such water master shall not thereafter divert onto the lands, the water for which has been so abandoned, any of such water, but shall divert such water from such stream so that it may be used on the lands to which such right has been transferred.

Under the regulations adopted by the board of irrigation, an applicant for a transfer of water or point of diversion must present his petition and affidavit upon a form which will be furnished from the State engineer's office, have the same indorsed by two users of water from the same stream who are not interested in his lands or water rights, and who are not related to him in any way, and reported upon by the water master of his stream. He must also, at his own expense, publish a notice (a form for which will be supplied) for thirty days in some newspaper published in the county where his point of diversion is located, naming a place and date where objections, if any exist, may be publicly presented against the granting of such certificate of transfer. Proof of publication of such notice must be presented by the applicant to the officer before whom the hearing is had, at the time and place specified in the notice. If no reasonable objections are offered why the certificate of transfer should not issue, and none is known to the officer, the water commissioner, or his authorized agent, will certify his approval of the application, which will then be forwarded to the State engineer for his action.

The provision in the regulation of the State engineer's office for a public hearing upon the merits of the application for the transfer of a water right gives all those who may be affected by the transfer the right to present their side of the case before final action is taken by the State engineer. Under the provisions of this law it is probable that some adjustment of the complications which have grown out of the selling and renting of water by the Almo Company might be effected. It is possible that the holders of decreed rights in Almo Creek by economical use of the water decreed to them, even when the amount of their decreed rights is limited to the legal allowance of an inch to the acre, might spare some small parts of their decreed quantities and so save the farms which have been developed by irrigation with water bought or rented from the Almo Company. After these farms have their rights established by legal transfers, then the excellent system of rotation in use of all the water diverted from Almo Creek can be practiced without question as to legality or objections from water users in the lower part of the district.

Since Raft River in the Raft River water district derives its entire supply from Utah watersheds, the question of the early adjudication of all water rights on the tributaries of Raft River rising in Utah and the enforcement, if possible, of the principle of priority of rights from the source of the streams in Utah to the end of the Raft River district in Idaho, regardless of the State line, are of importance to the water users of Raft River in Idaho. As conditions exist to-day, the water users in Idaho are unable to protect themselves against the wasteful use of water in Utah; but as soon as the headwaters of the river and its tributaries in Utah can be brought under the legal

administration which the State engineer of Utah is establishing in accordance with recently enacted laws, the waste and extravagance which so directly affect the Idaho irrigators can be prevented.

It might be said that if the water users on Raft River would take some pains to clean out their ditches and laterals and keep them clean from end to end, the service from the amount of water let in at their head gates would be much higher. In a valley like Raft River, where the temperature gets extremely high in the summer months, evaporation from water surfaces is high. When water in ditches is retarded by a growth of weeds or by the forming of pools in the uneven sections of the ditch, the loss from evaporation is much greater than when the water is kept running at a uniform velocity down a uniform grade. Ditches with a grade causing a scouring of the bottom to gravel also contribute to a heavy loss through percolation. Many ditches with these defects may be seen on Raft River and Almo Creek. The Almo canal has been cut to a depth of 20 feet below the surface of the ground in one place by the action of the water.

As land susceptible of irrigation becomes more scarce, the attention of home seekers will be attracted to just such valleys as Raft River, where the amount of water in the stream seems to be overabundant compared with the amount of land under cultivation along its banks. If a system of rotation in use of all the water in the river could be arranged, as has been successfully accomplished on many streams in Idaho without infringing upon the rights of early appropriators, the service of the supply could be enormously increased. Since upon Raft River proper there are only ten appropriators, it would seem a simple matter for them to arrange among themselves an equitable system of rotation whereby an inestimable benefit could be derived by all concerned. The hitch lies with the possessors of the earliest rights. They can see no benefit to themselves in the inauguration of a system of rotation. As progress is made toward a more just and systematic administration of Raft River, and when better and more scientific methods of irrigation are practiced, and more thought is given to obtaining a higher duty from the available water supply, and less attention is given to instituting lawsuits to protect water rights, Raft River and Almo Creek may be made to support between three and four thousand people instead of only three or four hundred, as is the case to-day.

# IRRIGATION INVESTIGATIONS AT NEW MEXICO EXPERIMENT STATION, MESILLA PARK, 1904.

By J. J. VERNON,

*Professor of Agriculture, New Mexico Agricultural College, and Agriculturist of the Experiment Station.*

## DUTY OF WATER ON ALFALFA IN NEW MEXICO.

The study of the duty of water on alfalfa reported here consisted of experiments in applying different quantities of water to different plats which received the same treatment in other respects, and in applying

<i>Group 1,</i>	<i>Plat 1.</i>		
<i>Group 2,</i>	<i>Plat 2.</i>		
<i>Group 1,</i>	<i>Plat 3.</i>		
<i>Group 2,</i>	<i>Plat 4.</i>		
<i>Group 1,</i>	<i>Plat 5.</i>		
<i>Group 2,</i>	<i>Plat 6.</i>		
<i>Group 1,</i>	<i>Plat 7.</i>		
<i>Group 2,</i>	<i>Plat 8.</i>		

FIG. 41.—Plat of field A.

like total quantities of water to different plats but watering the plats at different intervals of time, the object being to determine the quantities of water which will produce the largest crops, and whether a given water supply will do the most good when applied in frequent light irrigations or in heavier less frequent applications.

Two fields that had been in alfalfa for a number of years were selected for this experiment, two fields being selected for the reason that there was no single field upon the station farm large enough for the experiment. The arrangement of the plats in both fields is shown in figures 41 and 42.

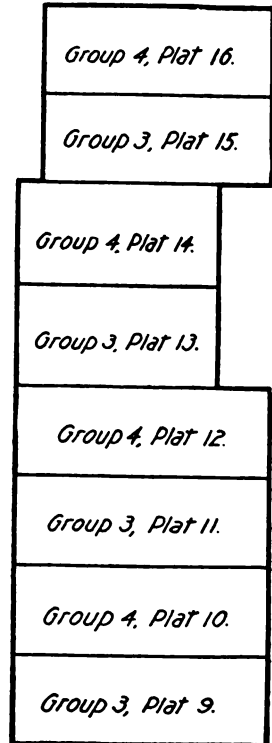

FIG. 42.—Plat of field B.

### SOIL.

The soil of both fields was loamy and as nearly uniform in character as any field to be found upon the station farm. The surface of the soil in both fields was fairly even, but the surface of field A sloped so rapidly that in order to control the water a number of cross borders were thrown up. Even then the water settled to a greater depth on the lower end of each section than on the upper end. The stand of alfalfa on both fields was good, but not first class.

### EQUIPMENT.

The equipment for pumping consisted of a 20-horsepower side-crank, slide-valve steam engine and a 20-horsepower semiportable steam boiler; one 6-inch centrifugal pump, which was placed upon the station well, described in Bulletin 45 of this station, and one centrifugal pump, which was placed upon the new station well. The engine and boiler mentioned above were used until July 1, when they were replaced by a modern 30-horsepower center-crank, slide-valve steam engine and a 40-horsepower semiportable steam boiler.

The equipment for measuring and controlling the water consisted of a trapezoidal (Cipolletti) weir and hook gauge. The weir was constructed according to plans given in Part I of Bulletin 86, Office of Experiment Stations, U. S. Department of Agriculture. The last 100 feet of the ditch leading to the weir was made as wide as the weir itself. The fall below the weir was at all times greater than the specified requirements. The water entering the several plats was controlled by gates.

After making a few runs it was found that the quantity of water discharged over the weir remained very constant when pumping, and therefore no other device for measuring the water was used throughout the season. The distance from the pump to field A was 1,204.5 feet, and to field B 950.5 feet. No allowance was made for loss by seepage and evaporation from the ditches, as it is believed that a comparatively small amount of water was lost by seepage for the reason that the soil is very heavy and the ditches had been cemented well by river sediment. This same equipment was used in the investigations into the cost of pumping upon various crops discussed later.

### LABOR.

While all the experimental work was in charge of competent assistants, one in the field and one at the pumping plant, Mexican laborers were employed in applying the water and in distributing it over the fields.

**METHODS OF IRRIGATION.**

The method of irrigation used in this experiment was that commonly known as the check system. Heavy borders were thrown up around each plat, and where necessary, in order to better control the water, cross borders were added. The water entered each plat at the upper end, spread out over the second section, and so on to the end of the plat. The distribution of the water was left very largely to the judgment of an expert Mexican irrigator, who was instructed to give each section its proper share of water. The growth of the alfalfa was not equally good upon all sections, but this difference might have been due to a variation in the amount of water applied or to a variation in the character of the soil of the different sections of each plat. Excepting the first and last crop, the alfalfa was cut regularly every four weeks just before the irrigations were given. The last crop grew very slowly for the reason that the nights were cool, and considerably more than four weeks were therefore required to produce this cutting.

Field A was divided into eight plats, numbered from 1 to 8, and these were thrown into two groups. Plats 1, 3, 5, and 7 formed one group and plats 2, 4, 6, and 8 formed the other group. The plats of each group received the same treatment except for irrigation.

Field B was also divided into eight plats, numbered from 9 to 16, and arranged in two groups. Plats 9, 11, 13, and 15 formed one group and plats 10, 12, 14, and 16 formed the other group.

All of the plats in field A received water enough to cover them to a depth of 6 inches during every four weeks, 3 inches being applied to plats 1, 3, 5, and 7 every two weeks and 6 inches being applied to plats 2, 4, 6, and 8 every four weeks. All of the plats in field B received water to a depth of 10 inches every four weeks, 5 inches being applied to plats 9, 11, 13, and 15 every two weeks and 10 inches being applied to plats 10, 12, 14, and 16 every four weeks.

The alfalfa was cut a sufficient length of time before the irrigations for it to cure and be removed from the field. Each plat was weighed separately. As nearly as possible the hay on all the plats was cured to the same degree of dryness, and every crop was removed from the field in good condition with the exception of the fourth, which was rained upon after it was cut. In order to irrigate at the proper time this crop was hauled in while it was still wet and was thrown into small windrows in the corral, where it was allowed to remain until dry. It was then gathered up and weighed. Under these circumstances there was an unavoidable loss of leaves, which, however, was probably about equal on all the plats.

The record of each group for the season is given below:

Group 1 received sufficient water to cover it to a depth of 3 inches every two weeks. It was irrigated April 4 and April 18, May 2 and



May 17, and the first crop was cut May 25, giving a growing season of 51 days, and having received 12 inches of water. The second crop was irrigated May 30 and June 13, and was cut June 24. The growing season for the second crop was therefore 30 days, and the land received 6 inches of water. The third crop was watered June 27 and July 11, and cut July 22, having a growing season of 28 days, and receiving 6 inches of water. The fourth crop was watered July 25, and August 8, receiving a total depth of 6 inches, and was cut August 19, having been growing 28 days. The fifth crop was watered August 22, September 5, and September 19, receiving 9 inches of water, and was cut October 20, after growing 62 days. This group received during the season of 197 days water to a depth of 39 inches, and yielded five crops, the average total yield for the group being 2.59 tons per acre.

The plats forming group 2 were irrigated every four weeks, and received enough water to cover them to a depth of 6 inches at each irrigation—that is, they received the same depth of water as the plats in group 1, but received it in less frequent, heavier waterings. The first irrigation of this group was one month later than the first irrigation of group 1, because it was originally planned to irrigate this crop with river water. River water was not available, and it was later decided to irrigate the group with well water, applying the same depth of water as on group 1, but applying it at longer intervals. The first crop was watered May 2 and cut May 25, giving a period of growth of 23 days. The second crop was watered May 30 and cut June 24, after a growing period of 30 days. The third crop was watered June 27 and cut July 22, having a growing period of 28 days. The fourth crop was watered July 25 and cut August 19, having a growing period of 28 days. The fifth crop was watered August 22 and September 19 and cut October 20, having a growing period of 62 days. The total depth of water received by this group was 36 inches, and the yield was 2.36 tons per acre, 0.23 ton per acre less than the yield of group 1, which received about the same depth of water, but received more frequent waterings. A part of this difference is due to the late watering of group 2, the first crop on group 1 being much heavier than that on group 2.

Groups 3 and 4 received the same depth of water, except for the first crop, group 3 receiving 5 inches every two weeks, and group 4 receiving 10 inches every four weeks. Group 3 was watered April 4, April 18, May 2, and May 17 for the first crop, receiving at each irrigation water enough to cover it to a depth of 5 inches. The first crop was cut May 25, after a growing period of 51 days. The second crop was watered May 30 and June 13 and was cut June 24, having a growing period of 30 days. The third crop was watered June 27 and July 11 and was cut July 22, having a growing period of 28 days. The

fourth crop was watered July 25 and August 8, and was cut August 19, having a growing period of 28 days. The fifth crop was watered August 22, September 5, and September 19, and was cut October 20, after a growing period of 62 days. The total growing season was 197 days, the total depth of water received was 65 inches, and the average yield 3.28 tons per acre.

Group 4 received 10 inches of water every 4 weeks. It was watered May 2 for the first crop, and was cut May 25, after a growing period of 23 days. The second crop was watered May 30 and cut June 24, having a growing period of 30 days. The third crop was watered June 27 and cut July 22, after growing 28 days. The fourth crop was watered July 25 and cut August 19, after a growing period of 28 days. The fifth crop was watered September 19, receiving 20 inches, and was cut October 20, the growing period being 62 days. The total growing period for the five crops was 171 days, the total depth of water 60 inches, and the average yield 3.17 tons. This yield was 0.11 ton per acre less than that of group 3, which received about the same depth of water in more frequent waterings.

In each field there is a very slight advantage in yield in favor of the more frequent waterings. As between the two fields, the field receiving water to a depth of 10 inches during four weeks showed a decidedly larger yield than the field receiving a depth of 6 inches during the same time, the average increase being 0.75 ton per acre. The field notes show that the field receiving only 6 inches of water in four weeks frequently showed the need of water, while the other field did not at any time appear to be suffering for water.

The following table gives the details as to the areas and yields of the different plats by groups:

*Yields of alfalfa on experimental plats.*

	Field A.							
	Group 1.				Group 2.			
	Plat No. 1.	Plat No. 3.	Plat No. 5.	Plat No. 7.	Plat No. 2.	Plat No. 4.	Plat No. 6.	Plat No. 8.
Area.....acres..	0.1891	0.2204	0.2282	0.2450	0.1889	0.2211	0.2286	0.2450
Yield, May 25, first cut....pounds..	120	150	180	320	80	82	164	143
Yield, June 24, second cut....do....	108	150	178	290	96	100	202	150
Yield, July 22, third cut.....do....	120	210	216	290	90	108	250	162
Yield, Aug. 19, fourth cut.....do....	158	226	140	410	152	222	340	240
Yield, Oct. 20, fifth cut.....do....	278	388	448	486	306	422	464	438
Total for season.....do....	784	1,124	1,162	1,796	724	934	1,420	1,133
Pounds per acre.....	4,145.95	5,099.81	5,092.02	7,330.10	3,832.61	4,221.33	6,211.55	4,624.49
Tons per acre.....	2.07	2.55	2.06	3.67	1.91	2.11	3.10	2.31
Average tons per acre for group....	2.59				2.36			

*Yields of alfalfa on experimental plats—Continued.*

	Field B.							
	Group 3.				Group 4.			
	Plat No. 9.	Plat No. 11.	Plat No. 13.	Plat No. 15.	Plat No. 10.	Plat No. 12.	Plat No. 14.	Plat No. 16.
Area .....	0. 2170	0. 2067	0. 1905	0. 1750	0. 2180	0. 2052	0. 1945	0. 1747
Yield, May 25, first cut .... pounds.	220	180	202	220	204	258	367	230
Yield, June 24, second cut .... do.	90	228	220	350	183	168	231	90
Yield, July 22, third cut .... do.	310	358	326	208	264	300	226	218
Yield, Aug. 19, fourth cut .... do.	254	270	320	472	308	256	344	430
Yield, Oct. 20, fifth cut .... do.	188	232	248	202	216	245	256	197
Total for season .....	1,062	1,268	1,316	1,452	1,175	1,228	1,424	1,165
Pounds per acre .....	4,891.75	6,134.49	6,908.14	8,297.14	5,389.91	5,984.40	7,321.34	6,657.07
Tons per acre .....	2.44	3.06	3.45	4.15	2.70	2.99	3.66	3.34
Average tons per acre for group .....	3.28				3.17			

The table shows great variation in yields from the different plats receiving the same treatment, but the averages fully justify the conclusions previously stated, that there is a decided increase in yield from the use of the larger quantities of water on field B.

**COST OF IRRIGATING ALFALFA WITH PUMPED WATER.**

The original plan included not only the determination of the cost of growing alfalfa by pumping, but also a comparison of the cost of producing alfalfa by means of river water and well water. Two fields of about equal size were selected, containing 3.4 and 3.14 acres respectively. They will be called fields C and D. Both fields were to have received the same treatment throughout, one to be irrigated with well water and the other with river water. But, on account of the river going dry, the field that was to have received the river water, after remaining idle for upward of one month, was irrigated with well water the remainder of the season. The irrigations were given to both fields at such times as the crops seemed to need it.

No definite amount of water was to be applied, but the quantity applied was measured, and so far as possible the irrigation of both fields represented the common usage of alfalfa growers in the valley except that clear water was used. An expert Mexican irrigator was placed in charge of the distribution of the water and was instructed to irrigate according to the common practice in the valley. An irrigation was given immediately after each crop was removed from the field.

The soil of field C was somewhat lighter than that of field D, the soil of field D being a heavy clay. Although the fields are not strictly comparable, in order to secure anything like accurate results in cost of

applying the irrigation water, the cost of harvesting, and the cost of storing, it was necessary to use the whole of a given area for the test. The surface of both fields was fairly even, but both slope too rapidly for the proper distribution.

The equipment used and the labor employed in these experiments were the same as for the experiments previously described. Field C was 130.5 feet from the pump and field D 701 feet. The check system of irrigation was employed.

The alfalfa was cut when it was from one-third to full bloom. When thoroughly wilted it was raked into small windrows and allowed to finish curing. On the third or fourth day after cutting it was bunched, hauled in, and stacked.

The following table shows the dates on which the fields were irrigated, the depths of irrigation, the dates of cutting, and the yields, reduced to an acreage basis:

*Dates of irrigation, depth of irrigation, dates of cuttings, and yields.*

FIELD C.

Cut.	Date of irrigation.	Depth of irrigation.	Date of cut.	Period of growth.	Yield per acre.
		<i>Inches.</i>		<i>Days.</i>	<i>Tons.</i>
First.....	May 25.....	5.85	June 9.....	a 15	0.39
Second.....	June 14.....	5.68	July 14.....	35	.51
	July 9.....	7.50	August 16.....	33	.89
Third.....	July 21.....	5.63	October 20.....	65	.50
Fourth.....	August 19.....	6.06			
	August 24.....	4.70			
Total.....		35.42		148	2.29

FIELD D.

First.....	April 1.....	6.81	} May 20.....	49	0.27
	April 25.....	3.79			
Second.....	May 24.....	5.75	} June 29.....	40	.51
	June 9.....	4.54			
Third.....	July 20.....	3.30	} August 8.....	40	.96
	August 11.....	5.40			
Fourth.....	August 18.....	2.65	October 13.....	66	.87
Total.....		37.46		195	2.61

<sup>a</sup>Alfalfa had made some growth before water was applied, as a result of rain and of irrigation the previous year.

The following table shows the date, the number of hours run, the amount of fuel consumed, the cost of pumping, the cost of applying the water, and the total cost for each irrigation, for each cut, and for the season. The cost of pumping includes coal at \$5.50 per ton and the wages of an engineer at 20 cents per hour.

*Cost of pumping and applying water.*

## FIELD C.

Cut.	Date of irrigation.	Time run.	Fuel.	Cost of pumping.	Cost of applying water.	Total cost.
		<i>H. m.</i>	<i>Pounds.</i>			
First .....	May 25 .....	9 00	1,609	\$6.22	\$0.68	\$6.90
	June 14 .....	8 44	1,495	5.87	.66	6.53
Second .....	July 9-11 .....	11 32	1,592	6.70	.86	7.56
	July 21 .....	8 40	1,360	5.41	.65	6.12
Third .....	August 19 .....	9 19	1,060	4.77	.70	5.47
Fourth .....	August 24-25 .....	7 14	1,046	4.32	.54	4.86
Total .....		54 29	8,162	33.35	4.09	37.44

## FIELD D.

First .....	April 1-2 .....	9 40	1,907	\$7.17	\$0.73	\$7.90
	April 25 .....	5 23	941	3.67	.41	4.08
Second .....	May 24 .....	8 10	1,450	5.61	.61	6.22
	June 9 .....	6 27	1,205	4.61	.48	5.09
Third .....	July 8-9 .....	7 24	1,067	4.41	.55	4.96
	July 20 .....	4 41	651	2.72	.35	3.07
Fourth .....	August 11-12 .....	7 40	1,218	4.91	.60	5.51
	August 18 .....	3 45	478	2.05	.28	2.33
Total .....		53 20	8,917	35.14	4.02	39.16

The following table shows the cost of irrigating, the cost of harvesting, the total cost, the cost per acre, the total yield, and the yield per acre for each cut and for the season:

*Cost of irrigation and harvesting and yields.*

## FIELD C.

Cut.	Cost of irrigating.	Cost of harvesting.	Total cost.	Cost per acre.	Total yield.	Yield per acre.
					<i>Pounds.</i>	<i>Tons.</i>
First .....	\$6.90	\$1.01	\$7.91	\$2.32	2,409	0.35
Second .....	14.09	1.66	15.75	4.63	3,125	.46
Third .....	6.12	1.48	7.60	2.24	5,431	.80
Fourth .....	10.33	1.28	11.61	3.42	3,084	.45
Total for season .....	37.44	5.43	42.87	12.61	14,049	2.06

## FIELD D.

First .....	\$11.98	\$0.87	\$12.89	\$4.12	1,715	0.27
Second .....	11.31	1.25	12.56	4.01	3,215	.51
Third .....	8.03	2.03	10.06	3.21	6,022	.96
Fourth .....	7.84	1.64	9.44	3.02	5,424	.87
Total for season .....	39.16	5.79	44.95	14.36	16,376	2.61

*Cost of growing alfalfa and value of product.*

	Field C.	Field D.
<b>Alfalfa in stack:</b>		
Cost of irrigation.....	\$37.44	\$39.16
Cost of mowing, raking, bunching, and drawing.....	5.42	5.79
Land tax <sup>a</sup> .....	1.84	1.70
<b>Total.....</b>	<b>44.70</b>	<b>46.65</b>
<b>Alfalfa baled, on board cars:</b>		
Cost of irrigation.....	37.44	39.16
Cost of mowing, raking, and bunching.....	2.06	1.98
Cost of baling at \$1 per ton.....	7.02	8.19
Hauling to cars.....	2.46	2.87
Land tax <sup>a</sup> .....	1.84	1.70
<b>Total cost.....</b>	<b>50.82</b>	<b>53.90</b>
<b>Value of crop at \$15 per ton.....</b>	<b>105.37</b>	<b>122.82</b>
<b>Total profit.....</b>	<b>54.55</b>	<b>68.92</b>
<b>Net profit per acre.....</b>	<b>15.04</b>	<b>21.95</b>

<sup>a</sup> The land tax was based on a value of \$20 per acre at a tax rate of \$2.70 per \$100.

**COST OF IRRIGATING WHEAT WITH PUMPED WATER.**

**PLAN.**

The data on the cost of pumping water for the purpose of irrigating wheat were secured in connection with experimental work in soil moisture, which was carried on in cooperation with the soil physicist.

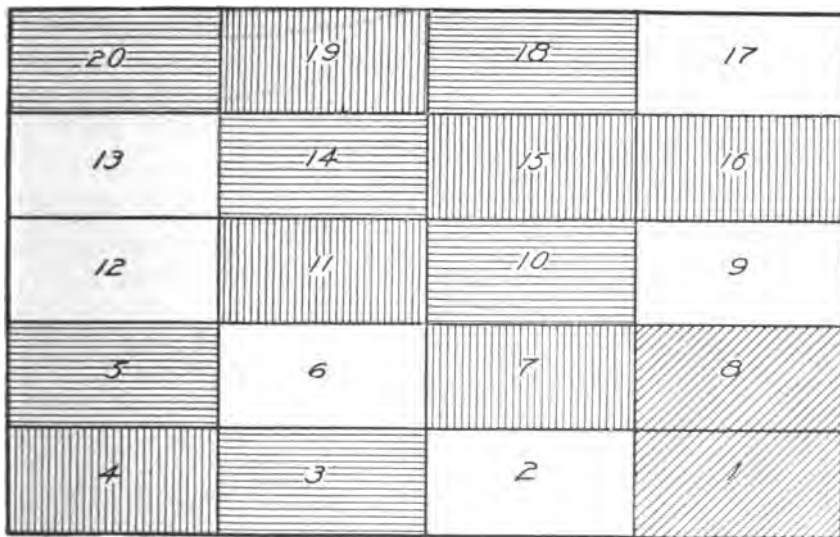





 *Group 1.*
 *Group 2.*
 *Group 3.*
 *Group 4.*

FIG. 43.—Plat of wheat field.

There were twenty plats of wheat of about one-tenth acre each, all of which were irrigated alike up to the time of heading (fig. 43). They were irrigated on January 5 to produce germination, on April 19,

when growth began, and on May 18, at which time the wheat began to head. After heading they were divided into four groups, the first three containing six plats each and the last one containing two plats, which were irrigated as follows: Group 1 was irrigated every week after heading; group 2, every two weeks; group 3, every three weeks, and group 4; not at all. Water was applied to a depth of 6 inches at each irrigation up to and including the one given at heading time. Thereafter the irrigation was variable, as shown in the tables which follow. It is probable that if the land had been quite level, less water would have been required to properly irrigate each plat. The condition of the land was, however, typical of the valley, lands seldom or never being in as good condition for the irrigation of wheat as they are for alfalfa.

The soil was variable, ranging from a rather heavy, sandy loam on the west side to a heavy adobe (clay) on the east. The groups of plats were selected so as to counteract this variability in the soil conditions, as will be seen by reference to the diagram. The surface of the land was rather uneven. The land was plowed to a depth of about 5 inches on December 8 and 9, 1903, and thoroughly pulverized and leveled by means of a rectangular frame made of 2 by 12 inch lumber set on edge.

The same equipment and labor were used as that in the experiments described in full on page 304.

On December 22, 1903, 2 bushels of wheat were sown per acre, 1.5 inches deep. A press drill was used, and the drills were 8 inches apart. The variety sown, Algerian White (station No. 410), has very large kernels, and for this reason 2 bushels were sown per acre instead of 1.5, the amount used with other varieties.

The check system of irrigation was used.

The wheat was cut on June 25, 1904, and was shocked and allowed to dry for a week or ten days, after which it was hauled to the machine and thrashed, the crop from each plat being kept separate and the quantity of straw and grain from each being recorded. The total time the crop occupied the ground was 186 days—from December 22, 1903, to June 25, 1904—while it made nearly all of its growth above the ground between April 19 and the time of ripening, or 67 days.

#### FIELD NOTES.

April 1. Good stand on all plats. Rabbits pasturing on south tier of plats.

May 1. All plats appear about alike. Effects of pasturing by rabbits practically overcome.

May 18. Beginning to head.

May 25. Heads well out; beginning to bloom.

June 1. Beginning to fill.

June 8. Watery stage; grain nearly full size.

June 15. Milk stage; grain full size.  
 June 22. Dough stage; grain full size.  
 June 22. Dough stage; ripening.  
 June 25. Ripe enough to cut.

### RESULTS.

The following table shows the depth of water applied before and after heading time, the total quantity applied, the yield per acre of straw and grain, the acre-inches of water required to produce 1 bushel of grain, the number of hours of pumping, the quantity of coal consumed, the total cost of pumping for each group, the cost of pumping per bushel of grain, and the cost of pumping per acre for each group:

*Cost of pumping water for the irrigation of wheat and yields of grain and straw.*

	Group 1. <sup>a</sup>	Group 2. <sup>b</sup>	Group 3. <sup>c</sup>	Group 4. <sup>d</sup>
Depth of water applied before heading .....	18	18	18	18
Depth of water applied after heading .....	17.3	11.2	6	.....
Total depth of water applied .....	35.3	29.2	24	18
Yield of grain per acre .....	18	16.6	15.1	10.6
Yield of straw per acre .....	1,947	1,901	1,450	1,207
Acre inches of water per bushel of grain .....	1.96	1.76	1.52	1.70
Number of hours of pumping .....	16 <sup>a</sup> 15 <sup>m</sup>	11 <sup>b</sup> 51 <sup>m</sup>	9 <sup>c</sup> 51 <sup>m</sup>	2 <sup>d</sup> 32 <sup>m</sup>
Fuel consumed .....	2,135	1,766	1,456	363
Total cost of pumping, per group .....	\$9.11	\$7.22	\$5.98	\$1.50
Cost of pumping, per bushel of grain, including fuel and engineer .....	.51	.51	.46	.49
Cost per acre .....	10.61	8.41	6.96	5.21
Value of grain per acre at \$1.20 per bushel .....	21.60	19.92	18.12	12.72

<sup>a</sup> Irrigated once each week after heading.  
<sup>b</sup> Irrigated every two weeks after heading.  
<sup>c</sup> Irrigated every three weeks after heading.  
<sup>d</sup> Not irrigated after heading.

The table shows that the largest yield was secured from the group receiving the greatest depth of water, but the largest return in proportion to the water applied was secured from group 3, which received the next to the least depth of water. Comparing group 1, which gave the largest yield per acre, and group 3, which gave the largest yield per unit of cost of pumping, an increased expense of \$3.13 was offset by an increased yield of 3 bushels of grain, worth \$3.60, a little more than enough to pay the increased cost.

### COST OF IRRIGATING CORN WITH PUMPED WATER.

The data upon which is based the following discussion of the cost of pumping water for the irrigation of corn were obtained in connection with a fertilizer experiment, which was carried on in cooperation with the Bureau of Chemistry, of this Department. The field covered an area of about 1.43 acres. All the plats were irrigated alike, and water was applied when the crop seemed to need it, five irrigations being given during the growing period of the crop. The first irrigation



was given on May 19, 1904, to produce germination; the second was given on May 28; the third on June 22; the fourth on July 13, and the fifth on August 4.

The soil was a heavy loam. The surface of the land was even but sloped rather too rapidly to secure an even distribution of water on all parts of the land. Several cross borders were thrown in, which assisted in preventing the water from settling to the lower ends of the plats. The land was plowed on May 12 and 13 to a depth of about 5 inches, and was then disked once and harrowed three times with the Acme harrow. Lastly, it was smoothed with the smoother heretofore described under "Wheat."

The corn was drilled with a 2-horse planter on May 18 to a depth of from 2 to 2.5 inches. The kernels were dropped 16 inches apart in the row and the rows were 3 feet 8 inches apart.

The corn was hoed once between June 1 and June 6, and plowed June 30 and again July 23. The check system of irrigation was employed.

The corn was cut and shocked on September 16, when it was beginning to show signs of maturing. It remained in the field until November 26, when it was hauled in, weighed, and immediately shucked, the weight of stover and grain being recorded. The total period of growth was 120 days, from May 18 to September 16. If the corn had been allowed to stand in the field until fully ripe, the time the crop occupied the land would have been somewhat lengthened.

The following table shows the number of hours of pumping, the quantity and cost of coal consumed for each irrigation, the cost of engineer, the cost of applying the water, the total cost of operating, the cost per acre, and the average yield per acre of stover and grain:

*Cost of pumping water for the irrigation of corn.*

Date of irrigation.	Depth of irrigation.	Time of pumping.	Coal.	Cost of fuel.	Cost of engineer.	Cost of applying water.	Total cost.
	<i>Inches.</i>	<i>H. m.</i>	<i>Pounds.</i> <sup>a</sup>				
May 19.....	6.18	4 00	600	\$1.65	\$0.80	\$0.30	\$2.75
May 28.....	4.50	2 55	437.5	1.19	.58	.21	1.98
June 22.....	4.63	3 00	450	1.25	.60	.22	2.07
July 13.....	6.05	3 55	587.5	1.54	.78	.29	2.61
August 4.....	3.86	2 30	375	1.01	.50	.19	1.70
Total.....	25.22	16 20	2,450	6.64	3.26	1.21	11.11

<sup>a</sup> Estimated from long runs.

Reduced to an acreage basis the cost of pumping and applying water was \$7.77 per acre. The yield was 31.9 bushels of grain and 6,521 pounds of stover per acre. The grain brought 90 cents per bushel at the time of husking, making a return of \$28.71 per acre in addition to the value of the stover.

**COST OF IRRIGATING SWEET POTATOES WITH PUMPED WATER.**

A field of 1.1 acres near the pump was selected and planted to sweet potatoes in order to determine the cost of pumping water on this crop. The irrigation was given as the crop seemed to demand it.

The soil was a heavy clay and not well adapted to growing sweet potatoes, but this was about the only land available for the work. The land was plowed to a depth of about 6 inches, thoroughly pulverized, and immediately thrown into ridges ready for planting. The same equipment was used and the same labor employed as heretofore described.

The plants were set out on June 13, 1904. The plants were located at the water line about halfway up the sides of the ridges, and the roots were pushed into the mellow soil with a wedge-shaped stick. An irrigation was given within two hours after the plants were set.

Cultivation was given between the ridges twice before the vines covered the middles, and one hand-hoeing was also given. After the vines had matted between the rows they were lifted from the ground once in order to check their tendency to root at the nodes.

The furrow system of irrigation was used, the water being run between the ridges until the furrows were about half full.

The potatoes were harvested November 1 to November 8, 1904. In harvesting, the vines were first removed from the surface of the ridges and raked into the middles. A small plow was run along each side of the row and then through the middle, the potatoes not removed by the plow being dug out with forks. The potatoes were placed in piles and covered with the vines, which were removed in the morning and replaced at night. After remaining in the field to cure for two or three days, the crop was hauled in, weighed, and sorted.

The following table gives the dates of irrigation, the depth of water applied at each watering, the time of pumping, and the quantity of fuel used:

*Cost of irrigating sweet potatoes with pumped water.*

No. of irrigation.	Date.	Quantity.	Time of pumping.	Fuel consumed.
		<i>Acre-inches.</i>	<i>H. m.</i>	<i>Pounds.<sup>a</sup></i>
1	June 13.....	4.28	2 38	357
2	July 23.....	5.34	3 17	448
3	August 5.....	3.50	1 35	214
4	August 16.....	4.50	1 55	260
	Total (4).....	17.62	9 15	1,279

<sup>a</sup>Fuel estimated.

The total period of growth was 124 days, the yield of unsorted potatoes was 10,100 pounds, or 9,182 pounds per acre. The total cost of pumping was \$5.35, or \$4.86 per acre. The sweet potatoes sold for 1.75 cents per pound, giving a return of \$160.69 per acre.

**METEOROLOGICAL CONDITIONS.**

The table following shows the mean temperature, relative humidity, wind velocity, and precipitation for the growing season of 1904, and compares these conditions for an average of the years 1898-1903, inclusive, and the year 1904:

*Meteorological conditions for the year 1904.*

Month.	Mean temperature.	Relative humidity.	Wind velocity per hour.	Rainfall.
	° F.	Per cent.	Miles.	Inches.
April.....	57.5	13.3	9.9	.....
May.....	68.0	18.0	9.5	0.05
June.....	76.9	25.1	9.9	.70
July.....	78.8	32.8	9.1	1.36
August.....	77.3	43.8	7.1	1.24
September.....	70.8	57.6	7.0	4.02
October.....	60.2	55.7	6.8	1.52
Average for 6 years, 1898-1903, from April to October, inclusive.....	69.95	42.8	7.37	8.30
Average, 1904, April to October, inclusive.....	69.90	35.2	8.5	8.39

NOTE.—The above table was supplied by Prof. J. D. Tinsley, station meteorologist.

**TEMPERATURE OF WELL WATER.**

There is a more or less common impression that the temperature of the well water in the neighborhood of Tucson, Ariz., is so low as to be harmful to plants. Records of the temperature of the water as it comes from the well and after it is spread on the field were kept throughout the season of 1904. The averages of these daily records are given in the following table:

*Average temperature of air and water.*

Plat.	Air at ditch.	Water at ditch.	Air in field.	Water in field.	Average rise in water.
	° F.	° F.	° F.	° F.	° F.
1.....	81	66.2	81.2	70.8	4.6
2.....	80.5	64.5	80.8	68.5	4
3.....	81.7	65.3	82	70.3	5
4.....	81.5	64.1	81.1	68.4	4.3
5.....	81.6	64.9	82.1	68.5	3.6
6.....	80.3	64.3	80.2	67.2	2.9
7.....	82.6	64.7	82.7	68.1	3.4
8.....	82	65.9	82.7	68.2	2.3
9.....	85.5	64.3	85	67.3	3
10.....	86.2	64.6	86.5	70.5	5.9
11.....	83.1	64.5	83.8	68	3.5
12.....	82.4	65.1	82.9	70.6	5.5
13.....	82.2	65.1	82.5	69	3.9
14.....	85.2	64.2	85.7	67.8	3.6
15.....	83.1	65.6	83.5	69.8	3.2
16.....	82.8	65.2	82.9	69.5	4.3
Average.....					3.9

As shown by the table the average rise in temperature between the well and the field was 3.9° F. So far no harmful effects have been observed from the use of this water. In fact the temperature of this well water is higher than the temperature of the river water in many places.

The following table compares the temperature of the well water used in these experiments with that taken from streams in the State of Utah on the same dates. This table shows that the temperature of the well water in New Mexico is on an average of 7° F. higher than that of the river water of Utah:

*Comparative temperatures of irrigation waters.*

Date.	Utah.	New Mexico.
June 13 .....	° F. 47	° F. 69.8
June 27 .....	55	67
July 11 .....	61	67.5
July 25 .....	64	68.7
August 8 .....	64	65.1
	60	67



# IRRIGATION INVESTIGATIONS IN WESTERN TEXAS.

By HARVEY CULBERTSON, *Agent and Expert.*

## INTRODUCTORY.

The accompanying charts of the rainfall and evaporation in Texas illustrate quite well the climatic conditions as affecting the growth of vegetation (figs. 44 and 45). The extreme west, with its 9 inches of rainfall and 80 inches of evaporation, shows the need of almost continuous irrigation for successful crop production. In that very dry air it is found necessary to give a crop of alfalfa two irrigations.

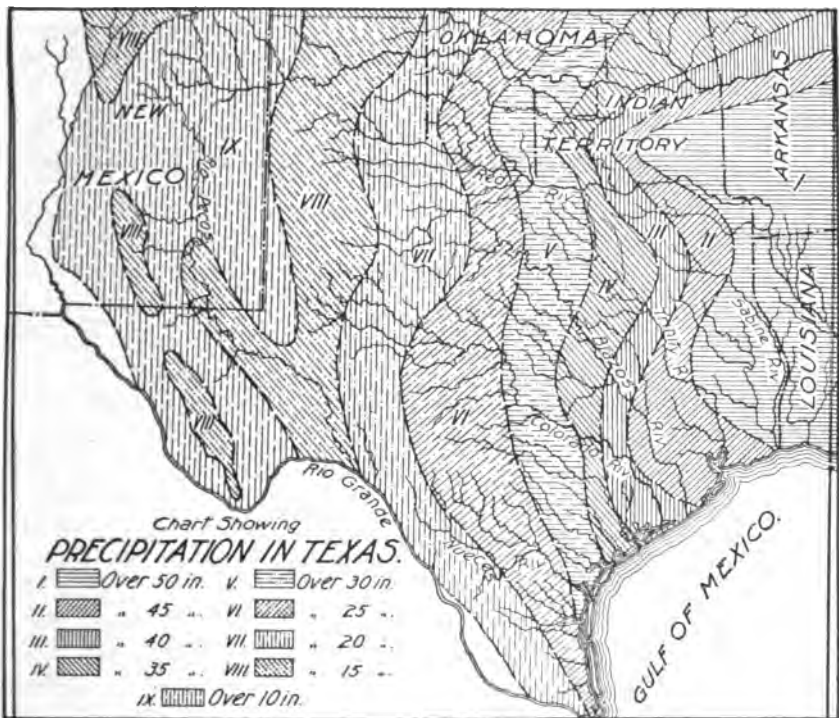

FIG. 44.—Chart showing precipitation in Texas.

Going eastward the rainfall increases and the evaporation decreases, the rainfall reaching 50 inches in the eastern part of the State. Between the two extremes a distance of about 750 miles intervenes. In the extreme west 25 to 40 acres of grazing land is required to furnish a rather scant subsistence to one beef animal. No farming is attempted without irrigation until a point about 350 miles eastward is

reached, and there is no reasonable assurance of fair crops until nearly 500 miles is reached, except in some sandy localities or under special local conditions. There have been some calls for irrigation enterprise as far as 600 miles eastward from the extreme western part of the State.

While the rainfall chart shows the amount of rainfall in different parts of the State, there is one important condition it does not show. That is the distribution through the growing season. Even with a rainfall of 25 to 30 inches good crops require that a large part of it fall in the growing season and an especially fair amount of it in the

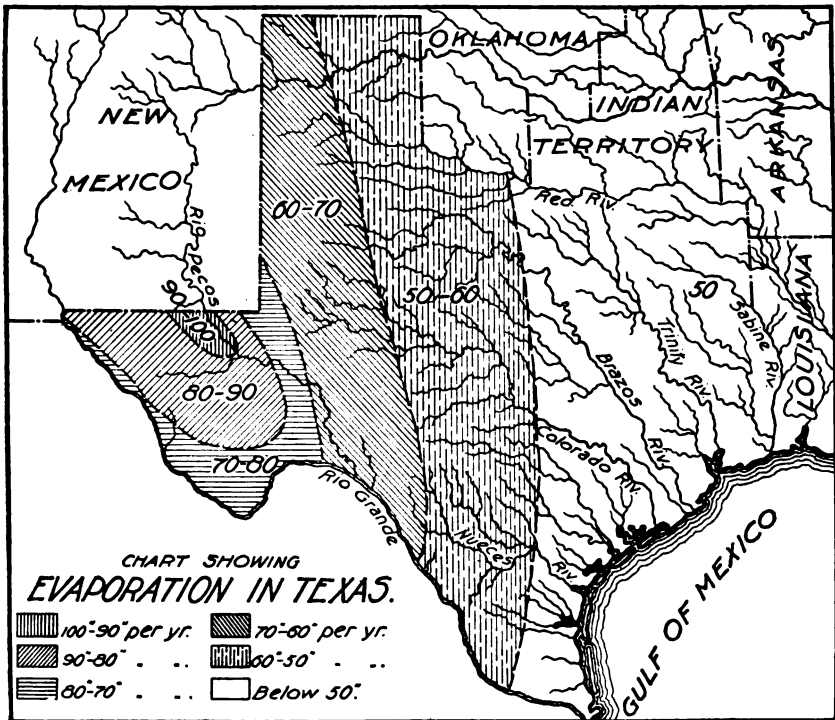

FIG. 45.—Chart showing evaporation in Texas.

warm months. Where rainfall is very heavy at times, with long intervals between, the conditions are unfavorable. The rainfall records given indicate a shortage in west central Texas during the months of July and August, with good supply in May, June, and September. Hence, nearly all the irrigation in this portion of the State is in July and August.

The following record of rainfall at Abilene, Tex., furnished by G. W. Eddy, weather observer, will be interesting. It gives the monthly rainfall for a period of 18 years. It shows a variation in annual rainfall from 15.71 inches to 35.30 inches, with an average of

24.50 inches. This is fairly representative of a large section of which it is fairly central. San Antonio and Amarillo are not greatly different.

Monthly and annual precipitation at Abilene, Tex.

Year.	Jan.	Feb.	Mar.	Apr.	May.	June.	July.	Aug.	Sept.	Oct.	Nov.	Dec.	Annual.
	In.	In.	In.	In.	In.	In.	In.	In.	In.	In.	In.	In.	In.
1885										2.61	0.23	0.98	
1886	0.11	0.61	2.47	1.67	0.33	3.38	1.48	2.03	4.17	2.24	.65	Trace	19.14
1887	.06	1.21	.03	2.45	3.95	3.26	2.71	1.10	2.64	4.77	.87	1.58	24.63
1888	.76	2.40	1.16	5.16	3.63	2.79	4.46	4.08	.05	2.00	4.80	3.29	30.58
1889	2.74	2.62	1.07	.71	2.93	6.36	1.80	.21	3.03	1.22	2.54	Trace	25.20
1890	.33	1.81	.14	9.80	2.69	.65	2.10	2.11	5.19	.97	2.10	.61	28.50
1891	2.11	.76	1.79	1.95	1.83	2.04	1.10	2.03	.64	.60	.12	2.60	17.57
1892	.30	1.04	2.59	1.68	6.12	1.34	1.41	3.58	1.85	6.03	.45	2.09	28.48
1893	.51	.33	.66	.28	5.78	.98	.52	3.36	2.30	.03	1.00	.52	16.27
1894	1.24	.75	1.66	1.23	6.49	3.30	.79	6.79	.64	1.17	Trace	.43	24.39
1895	1.15	2.32	.15	2.30	1.96	8.40	4.63	1.27	3.95	4.13	2.38	2.66	35.30
1896	1.44	.78	.14	1.11	.70	2.17	1.68	1.54	4.14	4.18	.38	2.48	20.74
1897	1.28	.02	4.02	4.74	4.73	3.90	2.00	1.87	2.89	1.32	.01	.52	23.30
1898	.75	1.08	1.41	1.78	2.60	4.55	1.46	1.94	3.44	Trace	.98	2.14	22.13
1899	.51	.01	.04	2.96	4.02	5.45	1.38	.10	.44	2.90	2.36	3.24	23.41
1900	.92	.58	1.54	5.43	4.11	.30	2.59	2.11	9.65	4.39	.24	.30	32.11
1901	.03	1.44	.72	.98	7.17	Trace	.28	.81	1.81	.61	1.50	.36	15.71
1902	.09	.31	2.25	.86	6.68	1.00	7.82	.06	3.13	2.00	2.46	.39	27.05
1903	1.51	4.07	2.31	.49	1.99	3.87	1.29	1.67	8.64	.42	.05	.22	26.53
Average.	.88	1.23	1.34	2.31	3.76	2.99	1.97	2.04	3.25	2.19	1.22	1.28	24.50

EL PASO.

Commencing in the western part of the State, El Paso has the first irrigation system. The Franklin ditch was built in 1889. It takes water from the Rio Grande and covers about 40,000 acres. Little land is irrigated, the area varying with the water supply, which is usually very small. Irrigation enterprises farther up the river in New Mexico get credit for taking part of the supply. Owing to the uncertainty of the supply of water in the river in the last few years over twenty-five pumping plants have been installed to furnish water when the river does not give sufficient. These pumps are of various sizes, discharging 150 to 1,200 gallons per minute. The water is pumped from wells which are about 50 to 60 feet in depth. The valley is underlaid with a stratum of gravel varying in thickness up to 23 feet, as far as tested, and this gravel bed and 30 to 40 feet of fine sand above it is full of water. The surface 10 to 15 feet is soil of a sandy nature. So far the supply of water seems to be ample for all demands. There is some question as to the source of supply. When there is water in the river the underground water rises, but the quality of the water next to the hills on the Texas side of the river is much better than it is in the middle of the valley, indicating an underground supply from the mountains. Present indications are favorable to the putting in of a great many more pumps. Pumps raising 500 gallons a minute or less have but one 6 or 8 inch well to draw from, while the larger pumps have two or three. Some of them would raise water cheaper to have more, for when the wells are furnishing a large amount the water is lowered so much that the expense of pumping is greatly increased.



From the tests made every 5 feet increase in lift increases the cost of fuel for pumping 1 cent for each 10,000 gallons pumped. The products grown are alfalfa, fruits, corn, and garden truck. Excellent prices are realized. Alfalfa hay, baled, is usually worth about \$15 per ton.

A short distance below El Paso, on the American side of the Rio Grande, there are three old Mexican ditches, which together water about 3,000 acres, and at various points along the river between El Paso and the mouth of the Pecos there are ditches watering small areas.

### TRANS-PECOS.

That part of the State between the Rio Grande and Pecos River is known as trans-Pecos Texas (fig. 46). It is semiarid, the average

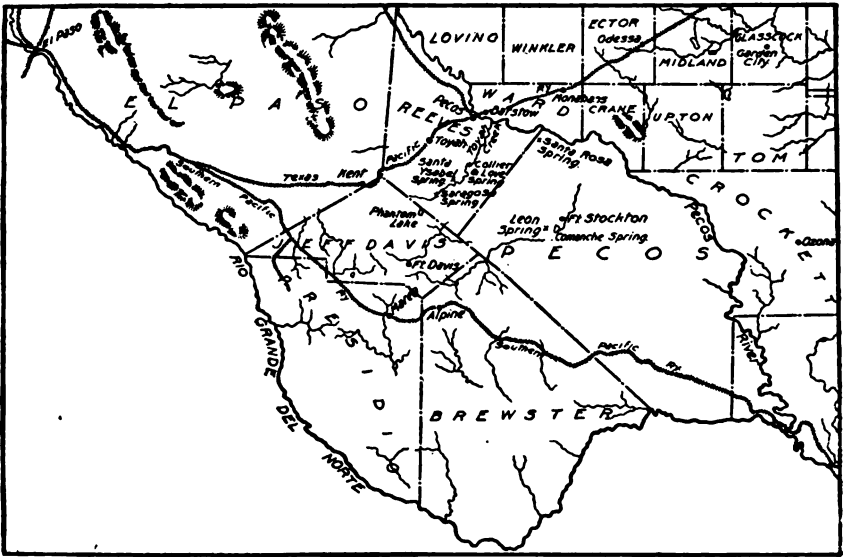

FIG. 46.—Map of trans-Pecos Texas.

rainfall for the western part being about 9 inches; for the eastern part about 12 inches, while it is subject to very long periods without any rain. It is a stock country, supporting twenty to twenty-five animals to the section, and no effort is made to grow anything without irrigation. Water is available for the irrigation of only a small part of it. The southwest part of it has a mountain range 5,000 to 10,000 feet high that seems to be a feeder to a portion of it. There are some good streams in the mountains, but they disappear on reaching the plain. In this plain some large springs appear, furnishing water for irrigation. The Santa Rosa Springs, not far from the Pecos River and about 20 miles south of the Texas and Pacific Railroad, furnish

water for 600 acres. Near Fort Stockton are the Comanche Springs with water for 3,000 acres. Ten miles west of these are the Leon Springs with water for 1,000 acres. Not nearly all the water from these springs is used for irrigation.

Not far from the head of Toyah Creek a large spring appears, coming out of an opening 9 feet wide and flowing about 4 feet deep. About 200 feet from this spring is Phantom Lake, into which this water flows and all disappears. The lake has no visible outlet. Part of the water is taken from the short stream for irrigating about 600 acres.

Toyah Creek originates in a large spring, the waters of which irrigate nearly 3,000 acres. Some 6 or 7 miles below is Saragosa Springs, irrigating 700 acres. Farther down is the Santa Ysabel Spring, irrigating 250 acres, and another, the Collier and Love Spring, irrigating 250 acres. The irrigation under these systems is largely for wheat and forage for stock.

South of Kent station, at one of the ranch houses of the Reynolds Brothers, is a spring irrigating 10 acres. All kinds of fruits and garden truck are grown. Near the mouth of Toyah Creek is a lake covering nearly 2,000 acres at low water and increasing to 3,500 acres at high water. Joining this lake on the west are the Hackberry Springs. They are in a section or more of marsh land. The springs proper are 20 to 50 feet across and 15 to 20 feet deep. It is proposed to put a ditch through these springs and secure a quantity of water for irrigation. Other springs supply water for small, isolated areas scattered through the trans-Pecos country. For the above facts in regard to the springs and irrigation from them we are largely indebted to Major Bomar, a civil engineer living in Barstow.

### PECOS ARTESIAN WELLS.

In the town of Pecos and immediate vicinity are about 80 artesian wells. They are used largely for irrigating gardens and for domestic purposes. No general irrigation is attempted. The soil is what is locally known as gyp. The wells have a force sufficient to raise water 25 feet above the surface in a pipe. The following is the log given by a well digger:

- (1) 18 to 20 feet, gyp.
- (2) 20 to 35 feet, quicksand.
- (3) 40 to 80 feet, white-looking clay.
- (4) 80 to 225 feet, alternating layers of gyp and sand.
- (5) 225 to 235 to 250 feet, gray-colored greasy clay.
- (6) Strata of gyp cobble.
- (7) Just above the water, 6 to 7 feet gray sandstone.

The depth of wells in the town of Pecos is 235 to 285 feet; 2.5 miles north of Pecos, 90 feet. Seven miles southeast a well close to Toyah

Lake just flows at the level of the lake. This artesian belt, so far as prospected, is about 10 miles long by 2 miles wide and all on the west side of the Pecos River. In a well 5 miles west of Pecos, 485 feet deep, the water stands 28 feet below the surface.

The Dixie Irrigation Company proposes the development of an irrigation enterprise on the west side of the Pecos River at this point, but the work has not progressed far.

### PECOS VALLEY IRRIGATION.

The Pecos River supplies water for irrigation in New Mexico and Texas. The volume of water varies with the season. In one of its flood times an engineer estimated its discharge at 41,000 cubic feet per second. The quality of the water is good when there is a good supply in the stream, but when it is very low the water is charged with common salt. There are three large irrigation enterprises in Texas that take water from Pecos River. The Barstow Irrigation Company has a charter calling for 1,020 cubic feet per second, but so far only about 200 cubic feet per second has been used, irrigating about 8,000 acres. The company has about 65 miles of main and lateral ditches. The main ditch is 30 feet wide on the bottom and capable of carrying water 6 feet deep. The crops grown are peaches, pears, grapes, cantaloupes, alfalfa, cotton, and forage for stock. The conditions for fruit production seem very favorable, and the time the products go on the market is quite advantageous. Five hundred acres have been planted to grapes, and 5-year-old vines have been doing well. The varieties grown with most success are the ones grown in California, the Muscat of Alexandria being the one in the lead. Cotton, under an intelligent system of cultivation, is giving satisfactory results. The first water contracts of the original company call for 40 acre-inches of water per acre in ten distributions at \$1.25. Later contracts give 25 acre-inches at \$1.75 per acre, and 40-acre water rights are sold for \$600.

The Pecos River Irrigation Company has a canal on the west side of the river heading about 28 miles below Pecos. It is about 12 miles long and was designed to irrigate 20,000 acres. Only a small area of land has been watered, because the river supplies very little water.

The Grand Falls Irrigation Company takes water from the east side of the river 18 miles south of Monahans station and a few miles below the head of the canal of the Pecos River Irrigation Company. It covers 30,000 acres and irrigates 6,000 to 8,000 acres. The quality of the water when the river is at a fair stage is good, but when the river is low it becomes considerably affected with common salt. The company contemplates water development for increased supply at low stages of the river. The crops grown are mainly alfalfa and cotton, with some forage. A beginning has been made in fruit growing,

especially grapes. The company contracts to furnish 12 acre-inches per acre, or sufficient to produce a crop, at \$1.25 per acre. Sales of improved land with water have been made at \$50 to \$100 per acre, while surrounding land is worth \$5 to \$10 per acre.

The method of irrigation under both of these systems is flooding for everything. Much of the land is cultivated by Mexicans, who get about one-third of a bale of cotton per acre where a good farmer will get a full bale.

### MONAHANS' WELLS.

At Monahans the Texas Pacific Railroad Company has wells 60 to 70 feet deep. A train load of water is taken every day to western points. A good many windmills in the village pump from bored wells. The soil is very sandy and fruit trees grow well where well irrigated. A peculiar feature of this region is the sand hills. These are  $\frac{1}{4}$  miles from the railroad wells and are over 150 feet above Monahans and 200 feet above the water in the wells. In some localities in these sand hills water can be had by scraping the sand away with the hand. Formerly there were small lakes in the sand hills.

### CONCHO, SAN SABA, AND LLANO RIVERS.

These rivers are all tributaries of the Colorado River on its west side (map, fig. 47). As sources of water for irrigation they are



FIG. 47.—Map of Concho, San Saba, and Llano rivers.

excellent. The quality of water is good and the supply is constant. Neither dry nor wet weather seems to affect the supply from the

springs from which they rise. The streams have their floods from the excess of water running off the surface, but the large springs that give the normal supply keep their regular flow.

On the North Concho, above Sterling, are three ditches. The upper one, or Kellis ditch, has been in operation fifteen years and irrigates 80 acres. It is a private system and cost thirty days' work for the owner with his four boys. It has been maintained in the same way. Grains, corn, cotton, sorghum, melons, and sweet potatoes are raised. Of some things two crops are grown per year. Wells in the low valley are 10 to 15 feet deep. These enter a bed of gravel which underlies the valley.

Next below is the McGee canal, owned by four or five persons. It irrigates 140 acres. Four and five crops of alfalfa are grown per year and yield 5 tons per acre. Johnson grass yields 3 tons per acre. Considerable areas of garden products are grown. Another dam below this has just been put in. It supplies water for 80 acres.

At Grass Valley are two ditches, together irrigating 250 acres. Cotton is grown under the upper one and feed crops under the lower one.

On the South Concho are five dams diverting water for irrigation, three of them owned by Mr. Metcalf. The lower one is near San Angelo. The ditch is rated by the owner as carrying 5,000 gallons per minute, and each of the other ditches at 6,000 gallons per minute. Together they irrigate about 1,000 acres. The Bismark farm has a ditch irrigating about 600 acres. On this place irrigation has been carried on for thirty years. This long-continued irrigation and cultivation has apparently had no bad effect upon the fertility of soil except for the growth of grain. This may be largely accounted for by the soil running together from irrigation and baking harder than formerly. Including the irrigation plant of the Twin Mountain farm there are five irrigation enterprises, all private, within 18 miles of San Angelo. A variety of products is grown. There is considerably more grain grown under these systems than was observed elsewhere. Probably one-third was cotton, with corn and Johnson grass coming in with fair areas. Near San Angelo there are several gardens. Irrigated lands are held at \$30 to \$50 per acre, except near San Angelo, where they are held much higher. Surrounding lands without water sell for \$5 to \$10 per acre.

At Christoval, on the upper South Concho, is another ditch carrying 5,000 gallons per minute, with over half as much more going to waste. The area irrigated is 600 to 800 acres, largely in cotton and corn. On Cole Creek, a branch of South Concho, above Christoval, is a small ditch, carrying about 500 gallons a minute, irrigating 75 to 100 acres.

At Knickerbocker on Dove Creek, another branch of the South Concho, there are two ditches, one on each side of the creek. About 1,200 acres are irrigated on the east side and 600 acres on the west side.

At this place Johnson grass seemed to be in the lead in acreage, cotton coming in as a close second. Alfalfa yields 5 tons per acre, cotton 1 to  $1\frac{1}{2}$  bales, corn 30 to 75 bushels, sweet potatoes 300 to 500 bushels per acre. One steam pump was put in this season to help out the water supply on one farm.

At Sherwood, on Good Spring Creek, another branch of the South Concho, there are three dams and ditches. In all about 800 acres is irrigated. The products grown are about the same as given above, except that there is more sorghum and Milo maize. Some extra large yields of cotton were reported. Some irrigation began in this vicinity in 1876.

Indications point to large seepage losses in the ditches in the Concho irrigation systems. Nearly all the irrigated land has a gravel bed underneath, which facilitates seepage losses, but the water gets back to the creek quickly and increases the supply for those below. One ditch was reported as losing half its water in 4 miles.

The San Saba River, getting its supply from springs, furnishes a large amount of water for irrigation. The principal ditches are near Menardville, about 75 miles above the mouth of the river. The Kitchen ditch, irrigating about 850 acres, heads about 6 miles below Menardville. The Noyes ditch, irrigating 2,000 acres on the south side of the river, heads 4 miles above Menardville. The Sieker ditch heads about 1 mile below the town on the north side of the river and waters about 200 acres. Above Menardville the Petmarcey ditch covers a small area. There are a number of large springs about 50 miles below Menardville that come out of the hills considerably above the valley land. One of these springs, flowing about 3,000 gallons per minute, is known as the Sloan spring. Irrigation began from some of the springs thirty-five years ago and there is now something over 500 acres irrigated from them. Less than one-half the water is used even during the months of heaviest irrigation. There are two springs east of San Saba irrigating about 60 acres. Cotton, corn, Johnson grass, and alfalfa are the principal products grown under all these ditches. One report of cotton yield was given as 3 bales from 18 acres of dry land and 9 bales from 6 acres of irrigated land. Besides these ditches, there are thirteen pumps irrigating about 1,500 acres. Under ordinary circumstances these pumps are run only ten or twelve hours a day. The pumps are all centrifugal; eleven of them use steam power, two of them gasoline engines. There are one 10-inch, three 8-inch, six 6-inch, one 5-inch, and two 4-inch pumps.

On the Llano River and its tributaries near Junction twenty-two ditches and springs were used in irrigating about 1,600 acres. Five parties pump water, irrigating 500 acres. The Llano Irrigation and Ditch Company has a newly made ditch near Junction, and is irrigating this first year about 500 acres. There are about 5,000 acres accessible.

At the company's diverting dam nearly all the water is taken from the river, 10,000 gallons per minute at the time it was visited; a large part of this was going back into the river some distance below the junction. In the 4 miles between this diverting dam and the town of Junction the river had increased to 22,000 gallons per minute. Some other good streams and springs come into it a short distance below. The impression gained from measuring the river at Junction and examining it at Llano was that nearly 50 per cent of the stream was lost by seepage in about 75 miles. Forty to 50 miles of the bed of the river is granite rock and sand.

Seven miles below Junction is a 40-acre tract of alfalfa supplied with water by water power. The field has been cropped continuously for fifteen years, and is still as fine a field of alfalfa as one ever sees. The pump runs ten months in the year. The owner claimed that by beginning early and getting the ground full of water before the growing season began he got better crops, and with the full capacity of the pump was able to irrigate and keep in good condition a considerably greater area than he could by beginning irrigation with the growing season.

The ordinary irrigating season on the three rivers mentioned covers about three months from the gravity ditches and two months from the pumps. The apparent common source of water supply for these streams is strikingly illustrated by an example on Clear Creek above Menardville. Within a short distance, at the head of this creek, about 5,000 gallons per minute comes out of springs. A ditch is taken out carrying a part of this water for irrigation. When the water is shut out of this ditch for cleaning there are two springs, one a mile away and the other  $1\frac{1}{2}$  miles, that lessen their flow of water. These springs are in separate ravines. When the water is let into the ditch the regular flow comes again. There is an outcropping of perforated rock that seems to underlie this section and forms an easy means of water flow from one place to another and renders storage dams in this section out of consideration.

The Colorado River below the mouth of the Concho is the source of a considerable water supply for irrigation by pumping. The difference between low water and extreme high water is about 50 feet. At present between the mouth of the Concho and the mouth of the San Saba there are seven pumps, irrigating about 1,400 acres. One of these pumps is a 12-inch centrifugal, delivering 5,000 gallons a minute, raising the water about 50 feet at low water in the river. This pump is near Big Valley post-office. The others are near Indian Creek and Regency. There are plans for the installation of quite a number of pumps during the coming year, some being already under way.

In the vicinity of Brownwood, on the Pecan Bayou, seven pumps are in operation, irrigating about 800 acres. Of the larger ones two

are on the Smith-Jenkins farm and another is on the Swindon-Pecan farm; two small ones are operated for garden work. Cotton is the principal crop irrigated in this portion of the State.

### COST OF IRRIGATION.

Circumstances vary so much that any exact figures are not to be considered. On the one hand are the large springs coming out above the land to be irrigated where the maintenance of a short ditch is all that is required. This would not exceed \$1 per acre for the year. On the other extreme is the pumping plant, raising water say 75 feet and using 18 or 20 cent gasoline, at a cost of more than \$10 per acre. To the fuel cost must be added the care, wear, and tear, repairs, expenses, etc., all of which vary. It might be safely placed in this case at \$3 per acre, making the cost of getting the water to the land more than \$14 per acre per year. A number of pumping plants have contracts to furnish water to neighboring lands at \$5 to \$7 per acre. The average conditions of central and western Texas, where the water is pumped, are fairly represented by the \$7 rate where gasoline engines are used for pumping. Where steam is used with wood for fuel at \$2 per cord the cost is less. All kinds of prices were found for gasoline used to run engines, ranging from 12 to 20 cents per gallon. In a number of places the fuel cost of pumping where gasoline engines are used was placed at \$1 per acre where gasoline was 16 cents and over.

The use of gas generators producing gas from crude petroleum with gasoline engines has shown some good results on tests of a few days' length. J. A. Smith, of El Paso, after making a four-day test found that with crude oil at 3 cents per gallon he could run his engine for \$1 per day of ten hours, pumping about 900 gallons a minute. A comparative test showed that \$4 per day was required with gasoline at 17 cents per gallon.

At Mesilla Park, N. Mex., with crude oil at 5½ cents per gallon, and gasoline at 20½ cents, the fuel cost of running ten hours on crude oil was \$3.05, and \$6.65 for gasoline. This last test was made by the officers of the agricultural college. While these tests seem highly favorable to the use of crude oil actual experience shows considerable doubt on the advisability of using it, the difficulty coming from all parts of the engine becoming so dirty and the generator itself becoming so filled with the hardened refuse as to cause very frequent and long delays. A prominent user of crude oil for gasoline engines, in California, recently made the statement in writing to your agent that he did not know of any generator that could be called a full success with the heavy oils having an asphaltum base, as have most of the crude oils of Texas and California.

It seems to be the usual custom in Texas to have quite a large plant for the area of land to be irrigated, so that they run only ten or twelve



hours a day, and then have intervals between irrigations. The first cost is greater than would be required if smaller plants were used, necessitating a greater amount to be added to the cost of irrigation for fixed charges. There is possibly in some instances greater economy in handling the water in larger quantities, but it must be confessed that frequently much water is wasted with the large plants.

The cost of irrigation from ditches taking the water from running streams ordinarily does not exceed \$2 per acre per year. This expense comes largely from the cost of keeping up a diverting dam and cleaning ditches. Most of the ditches are owned by individuals or by partnerships in which the owners do the maintenance work, hence there is very little actual cash outlay. Where stored water is used the cost per acre ordinarily runs higher, the cost of a well-built dam being much more than the ordinary cheap diverting dam that is in general use. Comparatively, only a small amount of irrigation is done with stored water. In most localities it would be a more sure source of supply and the water would be of a better quality. A number of pumping plants were tested to determine exactly the expense of pumping. In the following table giving results of these tests all the pumps are centrifugal except the last one, which is a high-duty steam Corliss engine fly-wheel pump. It was put in under a guaranty and worked better than guaranteed. It is placed in the table for the purpose of comparison to show the difference in high-grade machinery and the ordinary machinery in common use in pumping. The power for all the pumps in the table except the last two is the gasoline engine. The next to the last in the table is a company pump. It is run with steam, using wood for fuel at \$2 per cord, mostly oak wood:

*Tests of pumping plants.*

Name.	Rated horse-power engine.	Actual horse-power required. <sup>a</sup>	Gasoline used in 10 hours.	Size of pump	Lift.			Pumped per minute.	Cost per acre-foot.	Cost acre-foot, 1 foot.	
					Suction.	Discharge.	Total elevation.				
M. S. Cody .....	6	3.8	5	3	20	11.5	31.5	252	\$1.50	\$0.048	
H. Jensen .....	13	9	18	5	24	16	40	464	2.76	.069	
H. L. Ament .....	6	3.3	8	3	15	15.5	30.5	226	2.65	.087	
T. T. Cook .....	16	8.5	12.5	6	23	17.5	40.5	431	2.23	.055	
Frank Heath .....	10	6.8	10	5	24	14	38	368	2.05	.064	
George Pendell .....	20	12.9	15	6	21	11	32	832	1.38	.043	
W. C. Billingsley .....	13	6.2	12.5	5	20	9.5	29.5	431	2.21	.075	
B. S. Brown & Son .....	6	2.9	5.8	3	23	15.5	38.5	152	2.89	.075	
W. A. George .....	12	7.4	7.5	4	22	13.5	35.5	431	1.31	.037	
Julius T. Porcher .....	12	8.5	12.5	5	24	14	38	464	2.05	.054	
Charles Hopf .....	10	11.1	16.6	6	23	15	38	676	1.86	.049	
Edward Monwer .....	13	5	10.5	5	20	10.5	30.5	338	1.86	.061	
J. S. Porcher .....	15	9.2	15	5	22	11	33	576	1.98	.060	
J. A. Smith .....	28	16	32.3	6	21	12	33	990	2.48	.070	
Do .....	28	16	b 40	6	21	12	33	990	.66	.020	
Mesilla Park (1904) .....	22	20.3	b 54.4	6	23	15.25	38.33	1,089	.80	.021	
Do .....	22	20.8	c 34.2	6	24	7	15.25	39.83	1,082	2.39	.060
Do .....	22	21.3	32.9	6	25	15.25	40.25	1,096	2.37	.059	
T. J. Majors .....	10	3	12	3	-----	-----	33	190	4.42	.134	
Big Valley Co. (steam) .....	125	120	(d)	12	-----	-----	49.5	5,000	.99	.020	
Chase Nursery Co., Riverside, Cal., high-duty pump (steam) .....	-----	-----	-----	-----	-----	-----	247	-----	1.24	.005	

<sup>a</sup> Computed on an efficiency of 50 per cent.

<sup>b</sup> Crude oil at 3 cents.

<sup>c</sup> Coal oil at 14 cents.

<sup>d</sup> 4.6 cords of wood at \$2 per cord.

The first point to be noticed in the table is the rated horsepower of the engines as given by the agents selling them, and the next the actual power used to pump the water, as shown in the next column. The rated horsepower of some of them was raised when it was found that quite a large amount of gasoline was required. This was done to make a better comparison. Some of them make a very good showing by comparing the rated horsepower with the gasoline used in 10 hours. One gallon of gasoline per horsepower in ten hours is recognized as about the best result that can be reached. The comparison shows that a few plants approach this, and that several of the engines use 2 gallons of gasoline for 1 horsepower that is actually required.

The suction or distance of the water below the pump was obtained with the vacuum gauge, except in the last three cases. All of these pumps were drawing water from wells except the third and second from the last, which were pumping from streams. Two examples are given of the use of crude oil—one from J. A. Smith of El Paso, and one from Mesilla Park, N. Mex. Making a comparison of the final results as shown in the last column, the crude-oil tests make a fine showing. The actual results, however, are not so good. There is more delay and much cleaning required. For the larger engines, if one is prepared for gasoline and crude oil, the experienced persons in the use of crude oil claim considerable expense saved in fuel by its use. The engine required regular and systematic cleaning.

The last column contains the summary of the tests. The figures show the cost of raising 1 acre-foot 1 foot with gasoline at 14 cents per gallon. At some places it was only 12 cents, at others 17 cents, and at Mesilla Park it was nearly 20 cents, but for the purpose of comparing the relative efficiency of the different outfits the number of gallons used in ten hours was taken, and valued at 14 cents per gallon. The Big Valley Company makes a good showing in its steam outfit, raising 1 acre-foot 1 foot for 2 cents, which is less than half the cost with gasoline outfits. But this is done with wood at \$2 per cord, which is cheap. The last one, the Chase Nursery Company, of Riverside, Cal., shows the possibilities of high-grade machinery. In all the calculations for final results in the last column only fuel expense is considered.

#### **ECONOMICAL OPERATION OF PUMPS.**

One source of loss in the steam plants which everywhere impressed the writer was uncovered steam pipes and the tops of boilers and boiler domes. In a few instances steam pipe 75 to 100 feet from boiler to pump was exposed the whole length.

As to gasoline engines, some of the agents complained that the engineers would not turn off the fuel sufficiently to make an economical showing. Much fuel can be saved by being careful on this point. As

soon as the engine becomes well heated by running ten or fifteen minutes the supply can be cut off very much. As soon as the engine is well heated, turn off the supply very slowly until the engine shows a loss of motion, then turn on a little more. Some of the engines that show such low records could undoubtedly be improved with some other vaporizers.

It will be observed that some of the engines are so much larger than is required that a loss is experienced from that source. Near El Paso a loss is undoubtedly experienced from drawing the water so low in the wells. One or two more wells for some of the plants would most likely result in economy. The water level would not go so low, which would make a shorter suction. From actual test, a suction of 25 feet, as shown by the vacuum gauge, will cause the water to break at El Paso. A number of pumping plants were visited, but not tested. The following table contains the statements of their owners as to sizes, capacities, and areas served:

*Pumping plants not in list of pumps tested.*

Post-office.	Owner.	Kind of pump.	Size.	Power.	Rate per minute.	Area irrigated.
			<i>Inch.</i>		<i>Gallons.</i>	<i>Acres.</i>
Brownwood	Smith-Jenkins, etc.	Centrifugal	12	Steam	4,000	300
Do.	do.	do.	10	do.	3,000	150
Do.	do.	do.	3	do.	200	10
Do.	Swinden pecan farm	do.	8	do.	1,600	150
Do.	T. J. Majors	do.	3	Gasoline	190	15
Indian Creek	E. W. Plahu	do.	8	Steam	1,600	300
Brownwood	N. A. Perrie	do.	4	do.	400	35
Do.	Gran Ford	do.	6	do.	900	...
Do.	Mr. Cross	do.	do.	do.	do.	60
Do.	T. H. Windham	do.	6	do.	900	75
Regency	Jeff Young	Plunger	do.	do.	do.	...
Do.	James Lindsey	do.	do.	do.	do.	...
Do.	Mr. Perkins	do.	do.	do.	do.	...
Big Valley	Mr. Ezzel	do.	do.	do.	600	35
Do.	Big Valley Co.	Centrifugal	12	do.	5,000	500
Goldthwait	Mr. Randolph	do.	8	do.	1,600	200
San Saba	O. B. Kirkpatrick	do.	6	do.	900	45
Do.	John Jackson	Plunger	do.	do.	do.	5
Do.	C. L. Dunbar	Centrifugal	8	Steam	2,500	200
Do.	Thomas Hawkins	do.	4	Gasoline	400	50
Do.	Robert Ellis	do.	6	Steam	900	100
Do.	Mr. Nash	do.	4	do.	400	75
Menardville	M. Bethel	do.	8	do.	1,600	130
Do.	J. M. Stewart	do.	6	do.	900	90
Do.	J. C. Maxwell	do.	8	do.	1,600	180
Do.	Mack Reynolds	do.	5	do.	700	65
Do.	Decker Brothers	do.	6	do.	900	100
Do.	Doctor Dorr	do.	do.	do.	do.	...
Fort McKavett	W. L. Placker	do.	6	Steam	900	125
Do.	L. L. Ball	do.	10	Gasoline	3,000	200
Junction	George Bellerly	do.	5	Steam	700	150
Do.	M. C. Lindholm	Plunger	do.	do.	800	120
Do.	B. B. Kinney	do.	do.	do.	900	...
Do.	A. S. Etheridge	Centrifugal	6	do.	900	125
Do.	Mr. Scagg	do.	4	Gasoline	400	40
Do.	M. C. Blackburn	do.	4	Water power	400	50
Abilene	J. M. Ingle	do.	4	Steam	400	40
El Paso		About 15 pumps, but no special data.				

**SOME STATEMENTS OF CROP PRODUCTION IN TEXAS.**

The figures given below are those that seemed to have good backing as stated by conservative men. Some of them are considered to be full average results for a number of years. Some of them are average results for a whole ditch system.

At El Paso nothing is attempted by way of crops without irrigation. Mr. J. A. Smith gave the yield of alfalfa at 5 to 6 tons per acre, average price about \$12 per ton. A large part of the irrigation in that vicinity (about 30 pumps) is for garden stuff, sweet potatoes, melons, tomatoes, and chili, with all kinds of returns up to \$300 per acre, fruits giving the largest returns. Grapes from mature vines bring \$300 to \$400 per acre. Mr. Coffin in 1903 sold the pears from 25 acres for \$7,150.

At Barstow the yield of alfalfa is placed at 5 tons per acre, with prices ranging from \$12 to \$15 per ton; cantaloupes, \$60 per acre; grapes, \$75 to \$150 per acre; cotton under good conditions, 1 bale to the acre. The fiber of this cotton is said to be specially good.

At Sterling, J. M. Kellis has irrigated for over fifteen years by a gravity ditch from a constant stream. Oats yields 40 to 60 bushels, with a crop of corn following the oats; corn yields 50 to 60 bushels per acre; cotton yields 1 bale per acre. In this locality little effort is made to grow regular farm crops without irrigation. For the McGee ditch 5 to 6 tons of alfalfa per acre at \$10 is reported; 1 bale of cotton is given for this section. Considerable garden truck for local markets brings larger returns.

At Knickerbockers, Mr. Stephens reports yields as follows: Corn, 30 to 75 bushels per acre; sweet potatoes, 300 to 500 bushels per acre; alfalfa, 4 to 6 tons per acre; cotton, 1 to 1.5 bales per acre.

At Sherwood cotton yields were reported at 1 to 2 bales per acre; other crops as at Knickerbockers.

B. Metcalf, of San Angelo, reported cotton yields at 1 bale per acre; sweet potatoes at 400 to 500 bushels per acre; alfalfa, 4 to 5 tons per acre; Johnson grass, 2 to 3 tons per acre.

J. M. Ingle, of Abilene farm, near Putnam station: Corn, 80 bushels per acre; cotton, 700 pounds per acre; onions, 450 bushels per acre.

H. C. Ezzel, of Big Valley, reported melons, \$125 to \$150 per acre; cotton, 1 to 1.5 bales per acre. Cotton without irrigation averages about one-fourth to one-third bale per acre.

Mr. Ballard, of Big Valley, gave approximate results as follows: Before pump was put in it was a very scant living for himself and family. The first year under irrigation, though irrigation started late in the season, he was able to pay his share of the first cost and the

annual expense, had a much better living, and paid \$600 on debts, all from 30 acres irrigated.

At San Saba, V. C. Miller secured only 3 bales of cotton from 18 acres of unirrigated land. On irrigated land he secured 9 bales from 6 acres. Thomas Hawkins gave the average increase of yield from irrigation as three-fourths bale of cotton. T. A. Sloan rented his irrigated land (irrigated from a large spring above the land) on shares and got \$15 per acre rental.

At Menardville, under the Kitchen ditch, corn yields 40 to 70 bushels per acre; cotton, 1 to 2 bales.

At Junction, M. C. Blackburn gave average yields of alfalfa at 5 tons per acre on a 40-acre field that had been in alfalfa continuously for fifteen years.

Near Brownwood, on the Pecan Bayou, are five pumps drawing water from reservoirs in the creek. There are two 3-inch pumps, one 8-inch, one 10 inch, one 13-inch, also the Brownwood city pumps drawing from them. One of these pumps is irrigating 300 acres of cotton. The owner claimed that in the best of crop years the irrigated land produced at least double and often produced four times the average yield of unirrigated lands.

### METHODS OF IRRIGATION.

The method of irrigation in common use in western and central Texas for grain, Johnson grass, and alfalfa is flooding by means of borders to confine the water. The distance between the borders varies as the head of water to be used. When heads of 1,500 to 2,000 gallons a minute are available the borders are placed 60 to 75 feet apart, and less as the quantity of water is less. In the Pecos Valley this method is used for everything, such as corn, cotton, orchards, and vineyards. In most places the common method for cultivated crops is the row system. In the cultivation of the crops the earth is thrown up to the row, which makes a border out of every row. All the water that these furrows will safely carry is turned in for fifteen to thirty minutes, all the loose cultivated soil on top getting a good wetting. It runs together compactly and, if a clay soil, bakes very hard. It leaves the soil in condition for the largest possible evaporation. On new land full of vegetable matter or on quite sandy land very fair results are obtained. Old land or stiff clay land shows more the evils of this system of irrigation. By this method the Mexican irrigators in some localities produce only one-third of a bale of cotton per acre where good farmers get a whole bale. Where there is considerable slope to the land the water runs rapidly over, and the results are very little better than no irrigation. This method as generally practiced requires an irrigation every two weeks.

A method practiced on the Rio Grande at El Paso for strawberries and garden stuff has many points in its favor. The ground is thrown up in ridges, as if for planting sweet potatoes. It is then leveled down about halfway and a row of seeds or plants put in near each edge of this leveled-down ridge. The water is run in small streams in the furrows between the ridges. The water must run for several hours in these furrows. In this way only a small portion of the surface soil gets wet. Plenty of water goes under the ridge to wet the roots. This method leaves the ground in fine shape for the best of cultivation.

### STORAGE OF FLOOD WATERS.

The possibilities of irrigation by the storage of flood water are very large. The floods in the numerous rivers of the State, causing great destruction of property, indicate an abundance of water. Hundreds of farms in each of a great many counties could be irrigated and produce an abundance where now the farmer gets a scanty subsistence. A little has been done in this line. Perhaps the largest storage of water for irrigation purposes is at Wichita Falls. There are dams for storage of water for city supply in Abilene, Brownwood, and Cisco, each indicating the possibilities in this line. There are some reservoirs that have been contemplated for some years—one of these near Abilene, one near Brownwood, and one on the San Saba River—that have been fully surveyed and estimates made. The one near Abilene, on Elm Creek, is to hold 13,000,000,000 gallons of water and irrigate 30,000 acres. The drainage area is 147 square miles. The one near Brownwood, on Pecan Bayou, is to hold 11,000,000,000 gallons and irrigate 30,000 acres, and drain 750 square miles. This drainage area is ample for several such reservoirs. The engineer gave the necessary capacity of the wasteway as 40,000 cubic feet per second, and the estimated cost \$200,000. The reservoir in the San Saba River, as proposed, is to be made by a concrete dam where the bottom and sides of the stream are solid rock. This system when complete is to have a series of reservoirs below the main ditch. The stream is one that flows the year round, as well as being subject to great floods. The drainage area is very large. The scheme provides for the irrigation of 40,000 acres, and the estimated cost is \$600,000. The plan provides for a spillway with a capacity of 40,000 cubic feet per second. Each of these systems has a fine body of land under it. Each should increase the annual yield of products fully \$500,000 when fully developed.

To show the possibilities for whole counties, take the counties of Shackelford and Haskell. The first has one stream with 200 square miles of drainage area, one with 100 square miles, one with 75 square miles, one with 40 square miles, one with 30 square miles, two with 20 square miles each, two with 15 square miles each, and four with 5 to

10 square miles each. All of these when developed would irrigate 80,000 acres and ought to give an annual increase in value of farm products of over \$1,000,000. Haskell County has one stream with a drainage area of 300 square miles, two with 100 square miles each, one with 90 square miles, two with 75 square miles each, or altogether 740 square miles of drainage area. The average rainfall is nearly 24 inches in this locality. If 15 per cent of the rainfall goes into the streams it would allow the storage of water ample to irrigate 80,000 acres and increase the annual income for the county over \$1,000,000. The people of this section estimate that over 60 per cent of the rainfall goes into the streams from this rolling land. The lowest estimate made was 40 per cent. The estimate of 15 per cent is considered safe for land quite rolling or hilly. For level or sandy land it would be less. With this bright outlook for the different localities, and their possibilities under irrigation, it seems very difficult to interest capital to develop them. There are, however, thousands of places where small dams can be placed in ravines. These the individual farmer can develop during the months of fall and winter when other work is slack. The land has good clay subsoil, and the stockmen have abundantly proven with their earth tanks that water can be held in storage in a small way. Last winter one man living 10 miles from Albany made up his mind that he would at least have a good garden. He said he had been raising cattle and horses for twenty-five years and starving all the time, meaning that he had no vegetables. He put in a dam in a small ravine. In July he had as fine a garden as one ever sees, and that in a community where the drought was so severe that corn had not reproduced the seed. The dam was about 15 feet high in the low part of the ravine and 12 feet wide on top. The length on top was 200 feet; the outlet pipe was through the bottom. To get water on the garden it was necessary only to open the valve. The area draining into it was about 75 acres. In ordinary years it will give the water necessary for several acres.

Mr. Harvey, near Butler, put in two small dams the past winter. When the reservoirs are full of water the two will cover about 1.5 acres, probably about 5 feet deep. He had irrigated 10 acres up to the 1st of September. His increase in cotton would about pay the whole cost the first year. He was so well pleased that he was planning to put in one to irrigate 80 acres.

There are two reservoirs near Richmond—one owned by Mr. Hall and one by Mr. Wilcox. These are larger. One of them cost about \$1,500. Full particulars were not obtained.

From the numerous inquiries in this line the indications are that irrigation areas in Texas may be largely increased in the near future by the making of small reservoirs. Every acre put under irrigation

in this way will produce as much as 4 or 5 acres not irrigated in the drier parts of the State. The increase in valuation of land under irrigation for growing farm crops is rated at \$25 to \$40 per acre. Hence labor put into an irrigation system practically brings double returns, first in the sale of increased crops, and, second, in the selling value of the land.

#### POINTS IN BUILDING STORAGE DAMS.

The excessive rainfall coming in such a short time makes it imperative that provision be made for large volumes of waste water to get away without overflowing the dams and washing them out. The top of the dams should be from 3 to 6 feet higher than the bottom of the overflow wasteway, and the wasteway two or three times as wide as the stream when at its flush. In most soils the slope of the dam on the side next to the water should be not steeper than 2 feet horizontal to 1 foot vertical; on the other side not steeper than  $1\frac{1}{2}$  to 1. To prevent washing, some dams are sodded over with Bermuda grass and others are riprapped. In many places a core of some especially good clay is put into the middle. With a small dam made of clay this would not be necessary. The surface soil on the site of the dam should be removed in order to make a tight joint between the natural earth and the embankment. Surface soil should not be put on the side of the embankment next to the water.

#### SIZE OF RESERVOIR.

If an attempt is made to store all the water that may flow the reservoir should have capacity to hold 75,000,000 to 100,000,000 gallons of water for each square mile of land draining into it, the amount depending largely on whether the drainage area is quite rolling, rather flat, or sandy. Very little water would come off of sandy land.

#### LAND TO BE IRRIGATED.

The amount of land that can be irrigated safely in ordinary cultivated crops will be about 1 acre for each 500,000 gallons capacity in the reservoir. This gives fair allowance for seepage and evaporation. This would give four irrigations 3 inches deep. The amount of water required to cover 1 acre 1 inch deep is about 27,000 gallons; 3 inches, 81,000 gallons; four irrigations, 324,000 gallons. As is frequently the case, if the floods come in May or June and the water is used in July and August the above allowance for seepage and evaporation is too large. If alfalfa is to be irrigated the allowance should be increased to at least 750,000 gallons per acre.



## WINDMILL POWER.

The State of Texas has almost every possible condition in depth of wells. In a few places water can be had at 10 feet, and in different places at every depth down to 400 feet. To pump from these greater depths for irrigation, with any thought of competing in products with other localities, is out of the question. Where, however, fresh vegetables are properly appreciated water may be drawn from considerable depth in order to have them. The depth from which water may be drawn and produce a profit depends very largely on local conditions. There are points where garden products are sold at three to five times what they bring at other places. There are many places where water may be had in sufficient quantity at depths less than 100 feet, where irrigation from wells would be very desirable. It is the custom where wells of large producing capacity are found to do the pumping by steam or gasoline engine power. Where the supply is rather limited the windmill is used. To use the windmill successfully storage reservoirs are necessary. The two or three months of irrigation occur in the time of least wind. If there was as much wind during the irrigating months as in the others even then not over one-fourth of the year's pumping could be utilized. As it is, certainly not over one-sixth is used. To meet this difficulty storage is resorted to. The following table will give some idea of the water that may be pumped by a windmill, the size of earth tank or reservoir to hold it, and the number of acres it will irrigate. The speed is assumed at thirty strokes per minute:

*Quantity of water pumped, size of tank or reservoir, and area that may be irrigated by windmills.*

Water per stroke.	Pumped in 24 hours.	In one year by pump- ing one- half time.	Area it will irri- gate.	Size of reservoir to hold year's supply.	
				Area.	Depth.
	<i>Gallons.</i>	<i>Gallons.</i>	<i>Acres.</i>	<i>Acres.</i>	<i>Feet.</i>
1 pint.....	5,400	972,000	2	1	6
1 quart.....	10,800	1,944,000	4	1	6
1/2 gallon.....	21,600	3,888,000	8	2	6
1/4 gallon.....	32,400	5,832,000	12	2	9
1 gallon.....	43,200	7,776,000	16	2	12

The horsepower of different sizes of modern-gearred windmills, rated in a wind of 15 miles per hour, is as follows:

	Horse- power.
8-foot.....	0.35
10-foot.....	.65
12-foot.....	1.10
14-foot.....	1.65
16-foot.....	2.50

While these figures represent the horsepower of mills in a 15-mile wind it is rare that a mill is given even one-fifth of that amount of work to do. It is desirable that they should run in light winds. Generally they will accomplish more in that way than if arranged to pump a large quantity. The chief point of interest, however, to the irrigator is that by the storage of the water during the windy part of the year, when usually no irrigation is done, the area of land that can be irrigated is increased several times over what can be secured without storage. This calls for earth tanks. These tanks for clear well water require special treatment to have them hold water. Flood water running into a tank carries with it plenty of sediment that has the effect of making the tanks nearly water-tight. The clear water from wells in most places seeps away quite rapidly. To make them hold the bottoms and sides are well tamped when wet (better when water is over it). This should be repeated every year or two in many places. Complaints were frequently met of reservoirs having held well for a time and then commencing to leak.

The large amount of underground water within a reasonable distance of the surface makes the Staked Plains a place where windmill power for irrigation has room for large development. The winds probably are stronger and more constant than in any other part of the State. With ample tanks to hold the water over to the irrigating season a large part of these plains can be irrigated.

### ALKALI.

The presence of alkali in some localities led to a number of requests for aid in freeing the soil from its injurious effects. All have observed that alkali appears on the surface in dry times and none is seen after a wet period. The first rain that comes dissolves it and takes some of it down into the soil as far as the moisture goes. More rain takes it down farther. If there is sufficient rain and a subsoil that will let it down the rain will soon carry all the alkali out of reach. Such, however, is not the condition in localities where irrigation is a necessity. The rains cease when the alkali has been carried down only a short distance; dry weather begins, evaporation from the surface goes on, and in a short time all the rainfall is evaporated. The water goes into the air and leaves all the alkali on or near the surface. This suggests that if water enough is applied and there is drainage underneath to let it down the alkali can soon be taken out. Hence, in practice, tile drains are put in alkali soils and water applied sufficient to cause the water to run through the tiles. All the water that goes through the soil and out through the drains takes with it some alkali. It is necessary to keep the water applied only until enough alkali has been washed out to permit a good growth of vegetation. That will

take more or less time, according to the amount of alkali and the condition of the soil. Some alkali soils are very close and permit only a very slow movement of the water, and considerable time will be required to do the work. Such tenacious soils will improve in condition when the alkali is taken out. These conditions determine to some extent how near to each other should be the lines of tile. Thirty-three feet is as far apart as they should be to get the alkali out in a reasonable time. They should be at least 3 feet deep, and with sufficient fall to allow the water to run freely in them. The ordinary regulations for tile drainage are all applicable for alkali drainage. The same process applies to all kinds of alkali or salt.

## PUMPING PLANTS IN TEXAS

By C. E. TATT,

*Assistant in Irrigation and Drainage Investigations.*

### PLANT OWNED BY W. J. ALDERSON, NEAR KATY, TEX.

The equipment of this plant consists of a 25-horsepower engine, 9 by 12 inch cylinder, a portable boiler, and a 5-inch vertical centrifugal pump belted to the engine. The pump is submerged 14 feet in a 6 by 6 foot pit with 2-inch cypress curbing. The lift at starting is 48 feet.

The well has 8.25-inch casing with strainer made of perforated pipe wrapped with wire and gauze (fig. 48). Eight rows of 1-inch holes

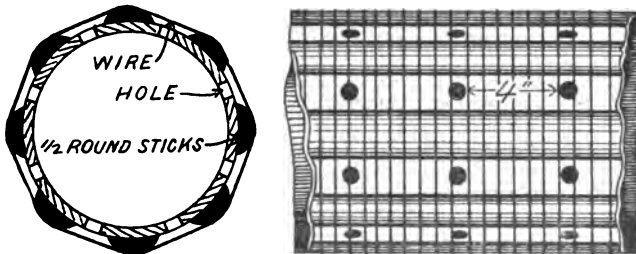

FIG. 48.—Strainer.

were drilled around the pipe in which the vertical distance between holes was  $\frac{1}{4}$  inches. One-half-round sticks were then placed between the vertical rows of holes and secured by wrapping with No. 12 gauge wire with a pitch of 0.5 inch. Wire gauze is placed over this and soldered. The one-half-round sticks and wire wrapping hold the screen at a slight distance from the surface of the pipe and the entire area of the holes is available. When this plant was visited the owner was placing additional length of strainer at the top of the first strainer, after which the well casing was to be withdrawn enough to expose the entire strainer. This was done because it was believed that the upper portion of the water-bearing stratum would be in contact with the new strainer and increase the supply to the well.

The fuel used was oil. The water was used to irrigate 100 acres of rice.

**PLANT OWNED BY JOHN COPE, JR., NEAR KATY, TEX.**

Mr. Cope has a 35-horsepower portable engine; a 5-inch vertical centrifugal pump belted to the engine with quarter turn in belt. The pump is in a pit, submerged 2 feet. The lift at starting is 33 feet. Oil is used for fuel. The well has 8.25-inch casing with 75 feet of strainer like that used on the well of W. J. Alderson, just described. At first only 35 feet of strainer was used, but in order to increase the supply of water 40 feet of strainer of a smaller diameter was telescoped below by the use of the sand bucket. The pit is 6 by 6 feet, curbed with 2-inch cypress. The water is used on 86.5 acres of rice.

During the first irrigation of the season about 5 acres per day is covered. The water in the well is drawn below pump to an unknown depth. It usually requires over a week for it to regain its original level.

**PLANT OWNED BY A. E. DORN AND L. E. RECTOR, NEAR KATY, TEX.**

This plant consists of a center-crank 75-horsepower engine with two 66-inch band wheels running at 170 revolutions per minute, a 100-horsepower stationary return-flue boiler, and two 5-inch vertical centrifugal pumps. Each pump is connected to two wells in the same pit, one of the wells in one pit being 220 feet deep with 40 feet of strainer and the other 100 feet deep with 35 feet of strainer. In the other pit one well is 150 feet deep with 35 feet of strainer and the other 80 feet deep with 15 feet of strainer. The engine is placed between the two pumps, and belts extend in opposite directions from the two band wheels on the engine to the pumps. The distance between centers is 50 feet; the size of pulleys on the pumps 12 inches. One pump is submerged 6 feet and the lift at starting is 50 feet. The owners believe that very little was gained by sinking two wells so near together in the same pit. If the two pumps are used alternately the water in one well rises while the other one is being drawn upon. The water is used on 170 acres of rice.

The strainer used consists of well casing having 0.5-inch holes and wound with galvanized iron or copper wire with a pitch suitable to the coarseness of the sand and gravel in which the strainer is to be used. The wire instead of being round is of a special form so that the spaces in the winding are smallest at the outside, and any particle entering will easily pass through and not wedge in to clog the slot (fig. 48). The water enters at any point and travels to a hole in the casing, thereby increasing the usefulness of the strainer.

**PLANT OWNED BY J. C. REXROAT AND J. H. CHAPMAN, NEAR BROOKSHIRE, TEX.**

This plant consists of a 45-horsepower engine, cylinder 10 by 15; a 60-horsepower stationary engine burning wood, and a 9½ pitless pump with 60 feet of shafting and 3 impellers in water. The well has 10-inch casing, is 93 feet deep, and has 35 feet of strainer. When the well was first used the strainer filled up with sand to a depth of 12 feet. This was removed by the use of the sand bucket. The lift at starting is 5.5 feet. The estimated discharge is 350 gallons per minute.

The pump requires no pit and consists of a head supporting a shaft which is dropped into the well casing. The shaft carries impellers, similar to an auger, which rotate at high speed in small stationary cylinders. These cylinders are "lined up" with the shaft and not with the well casing.

The water is used on 76 acres of rice. In 1904 water was first applied on July 26. The rice was at this time about 18 inches high but very thin and could hardly be seen for weeds. The field was mown and when water was applied the weeds were killed, leaving a fair stand of rice.

**PLANT OWNED BY JOHN GASNER, NEAR BROOKSHIRE, TEX.**

Mr. Gasner has a 54-horsepower gas engine and a 5-inch vertical centrifugal double-suction pump. The lift at starting is 52 feet. The well is 137 feet deep, and has 10-inch casing with 47 feet of strainer. The pump was placed in a pit 6 by 6 feet, curbed with 2-inch cypress. A 6-inch pump was at first used, but it was thought that the 54-horsepower gas engine did not furnish enough power to run it and when the plant was visited the owner was replacing the 6-inch pump by a 5-inch. A 32-horsepower traction engine had been used in sinking the well and this engine was tried with the 6-inch pump. The owner believes it furnished more power than the 54-horsepower gas engine. When using oil for fuel 0.1 gallon per horsepower hour was required, and when using distillate 0.125 gallon per horsepower hour was required.

Mr. Gasner expects to irrigate 210 acres of rice and had made two other 10-inch wells, one 142 feet deep and the other 152 feet deep. Both had 45 feet of perforated pipe without any wrapping.

**PLANT OWNED BY W. J. METTLER, NEAR STILSON, TEX.**

Mr. Mettler has a secondhand sawmill engine, with 12 by 20 inch cylinder, running at 120 revolutions per minute, 72-inch band wheel; a secondhand sawmill stationary boiler using 60 pounds steam pressure; and a 9½-inch pitless pump with 10-inch pulley and 30 feet of

shafting. The well has 10-inch casing and is 450 feet deep, having a strainer of perforated pipe wound with wire. The cost of the well was \$1,485, or \$3.30 per foot. The cost of engine, boiler, pump, and fittings was \$1,100. Total cost of plant was \$2,585, or \$17.83 per acre. At first irrigation the plant waters about 8 acres in twenty-four hours. The lift at starting is 12 feet. The estimated discharge is 350 gallons per minute. When this plant was visited the engine was running at a varying speed on account of the improper working of the governor. Water is used on 145 acres of rice.

#### **PLANT OWNED BY M. B. SAPP, NEAR STILSON, TEX.**

Mr. Sapp has an 18-horsepower gas engine, a 4-inch vertical centrifugal pump, and a well 400 feet deep, with strainer of perforated pipe wrapped with wire. The lift at starting is 15 feet, the estimated discharge 400 gallons per minute.

Mr. Sapp has another plant, consisting of a 35-horsepower second-hand engine, a secondhand stationary boiler, and a 6-inch vertical centrifugal pump. Oil is used for fuel. The lift at starting is about 15 feet, the estimated discharge 700 gallons per minute.

#### **PLANT OWNED BY HILL-BROWN RICE LAND AND IRRIGATION COMPANY, NEAR STILSON, TEX.**

This plant consists of a 25-horsepower gas engine and a 6-inch vertical centrifugal pump. It requires 1.75 barrels of gasoline per day for fuel. The lift at starting is 13 feet, and the pump is submerged 7 feet. The water, together with that from another plant belonging to the company, is used on 250 acres of rice. The engine runs at 210 revolutions per minute, and when visited was exploding each revolution. The cost of the plant was about \$2,500.

The company has another plant, consisting of a 35-horsepower engine, a portable boiler, and a 6-inch vertical centrifugal pump with double discharge. The well has 10-inch casing, 240 feet deep. The estimated discharge is 450 gallons per minute. The lift at starting is 14 feet and the pump is submerged 26 feet.

The pump is a variation of the vertical centrifugal pump, which is placed in a steel pit 30 inches in diameter. An auger is placed at the bottom of the steel pit, and before the pump is placed in it the pit is lowered into the ground around the well casing by the jet process of sinking wells. The casing is then cut off inside and the pump is then lowered to the bottom of the pit. The bearings on the shaft are inclosed in and held by a 4-inch pipe. The pump has two discharge outlets on opposite sides of the center. At first the pit was utilized as a discharge pipe, but it was found that some wells would fill it with sand and cover the pump. Water or oil is put into the 4-inch pipe

inclosing bearings to lubricate the shaft. The pit is designed to be used where quicksand prohibits the sinking of an ordinary pit for centrifugal pumps.

#### **PLANT OWNED BY D. M. CAFFELL, NEAR STOWELL, TEX.**

Mr. Caffell has a 16-horsepower traction engine, steam pressure 130 pounds, speed 220 revolutions per minute, and a pitless pump with 30 feet of shafting. The band wheel on engine is 42 inches in diameter and is belted to a 14-inch pulley on a jack shaft. The jack shaft carries a 30-inch band wheel, which is belted to a 10-inch pulley on pump shaft. If there were no slip in the belts this arrangement would give the pump a speed of 1,980 revolutions per minute. Eight barrels of oil is required for fuel in twenty-four hours. The water is used on 90 acres of rice. The well is 310 feet deep and at times gives an artesian flow. The estimated discharge of pump is 500 gallons per minute. The pump requires no pit, and is similar to the pump belonging to Mr. Rexroat, except that the impellers rotate in the well casing instead of in small stationary cylinders. The speed must be very high and the impellers are usually badly worn by the well casing, which is sometimes crooked.

#### **PLANTS OWNED BY TEXAS LAND AND IRRIGATING COMPANY, NEAR STOWELL, TEX.**

Well No. 3 belonging to this company is fitted with an 8.25-inch pitless pump and an 18-horsepower traction engine, which runs at 200 revolutions per minute. The band wheel on the engine is 40 inches in diameter, the pulley on the pump shaft 8 inches in diameter. The well is 540 feet deep, and has 91 feet of strainer made of perforated pipe covered with woven-wire gauze. This well gives salt water, but when used with that from other wells the water does not damage rice. The estimated discharge is 250 gallons per minute. A vacuum pump was first used on this well, but it was unsatisfactory.

Well No. 4 is fitted with a pitless pump and is 210 feet deep. Well No. 5 is fitted with a centrifugal pump and is 180 feet deep. Both of these pumps are run by a 45-horsepower engine, 10 by 16 inch cylinder, with a speed of 150 revolutions per minute. The band wheel on engine is 48-inch, and the pulley on the pump 8-inch. The estimated discharge of well No. 5 is 200 gallons per minute. The centrifugal pump has not been satisfactory and will be replaced.

Well No. 1 is fitted with a 6-inch vertical centrifugal pump. Well No. 2 is fitted with a pitless pump. Both of these pumps are run by a 40-horsepower engine, 10 by 14 inch, speed 200 revolutions per minute. The band wheel on engine is 40-inch, the pulley on the pump, 8-inch. Steam for both engines is supplied by two portable boilers.



Steam for the engine is piped a distance of 360 feet. The pipe is laid on the surface of the ground, is wrapped with tar paper, and the whole boxed. It is found that this gives a great loss. The two boilers require 30 barrels of oil per twenty-four hours.

The five wells of the company supply water for the irrigation of 540 acres of rice. All of the wells are flowing at certain seasons of the year, but after pumping has continued for a time the water level in the wells is drawn about 20 feet below the surface.

### PRICES.

A pit for a centrifugal pump made near Katy, Tex., is claimed to have cost \$3,000 on account of the trouble given by quicksand. The pit was begun in 1903, but was not completed until 1904.

A pit for a vertical centrifugal pump was made near Stilson, Tex., which cost \$500. It was the intention to make the pit 27 feet deep, but quicksand was encountered and the work was given up when it was lowered to a depth of 20 feet.

The price charged for sinking 8-inch wells at Katy, Tex., is \$4 per foot, with pipe and strainer furnished by the well driller. When two wells are made at the same place, the price is reduced to \$3.75 per foot.

The price charged for sinking wells and furnishing the casing and strainer at Stilson, Tex., is \$3 per foot. It was not learned whether the amount of strainer is limited in these or not.

Mr. W. H. Weller, near Brookshire, Tex., has had six wells made on his farm, but none furnished enough water to make pumping worth the while. Pumping plants are operating successfully on all sides of his farm. The first well was made by a well driller who guaranteed to make a well that would supply 600 gallons per minute, for which he was to receive \$600 and \$1 for each additional gallon per minute. A second well driller made five wells under the same agreement, with no better results. The best of the six wells furnished only about 100 gallons per minute.

Four-inch vertical centrifugal pumps sell for \$68 to \$80 in Houston. Pitless pumps with 20 feet of shafting cost \$250 for 8.25-inch wells and \$275 for 9 $\frac{1}{8}$ -inch wells. Each additional 10 feet of shafting costs \$25 for 8.25-inch wells and \$27.50 for 9 $\frac{1}{8}$ -inch wells.

Six-inch pumps with steel pits and all fittings cost \$378 in Houston, Tex., the pump alone costing \$125.

The strainer when wound with iron wire costs \$4 per foot for the 9 $\frac{1}{8}$ -inch size and \$2.70 per foot for the 6-inch size. When copper wire is used \$1.50 per foot is added.

## IRRIGATION IN SOUTHERN TEXAS.

By AUG. J. BOWIE, Jr.,

*Agent and Expert, Irrigation and Drainage Investigations.*

### DISTRICT INCLUDED IN REPORT.

The district of Texas included in this report lies south of the line through Del Rio, San Antonio, and Port Lavaca, with the addition, however, of the upper Nueces and Frio River valleys. Unless stated to the contrary, statements are intended to apply to that district alone. (Pl. V.)

### RAINFALL IN TEXAS.

The following table is taken from the Monthly Weather Review for April, 1902, and comprises all available and reliable data the Weather Bureau had pertaining to rainfall in Texas:

*Rainfall in Texas.*

Station.	Latitude.		Longitude.		Elevation above sea level.	Record.		Average annual precipitation.
	From—	To—	Years includ- ive.	Inches.				
	° /	° /	<i>Feet.</i>					
Abilene .....	32 23	99 40	1,738	1885	1901	16	24.22	
Amarillo .....	35 13	101 50	3,676	1892	1901	10	21.55	
Austin .....	30 16	97 43	650	1856	1901	37	33.51	
Brenham .....	30 02	96 02	350	1885	1901	12	38.30	
Burnet .....	30 56	98 01	1,395	1889	1900	9	28.62	
Eagle Pass .....	28 39	100 30	800	1849	1901	28	23.06	
Corpus Christi .....	27 49	97 25	18	1846	1901	14	26.28	
Cuero .....	29 03	97 09	177	1883	1901	10	33.76	
Dallas .....	32 55	96 38	466	1889	1901	9	33.22	
El Paso .....	31 47	106 30	3,762	1850	1901	38	8.84	
Fort Brown .....	25 50	97 57	67	1850	1901	28	25.52	
Fort Clark .....	29 17	100 25	1,050	1852	1901	28	21.87	
Fort Concho .....	31 55	100 17	1,950	1872	1889	15	23.70	
Fort Davis .....	30 40	104 07	4,700	1855	1891	20	18.10	
Fort McIntosh .....	27 29	99 31	460	1849	1900	34	19.05	
Fort Ringgold .....	26 27	98 47	230	1849	1901	38	19.80	
Fort Stockton .....	30 50	102 35	4,952	1859	1899	14	16.10	
Fort Worth .....	32 50	97 15	670	1849	1901	8	34.32	
Fredricksburg .....	30 20	98 45	1,742	1877	1901	17	28.32	
Galveston .....	29 18	94 50	54	1868	1901	33	48.13	
Houston .....	29 48	95 19	53	1882	1901	12	45.20	
Mount Blanco .....	33 55	101 01	.....	1886	1901	13	15.93	
Palestine .....	31 45	95 40	510	1882	1901	19	44.14	
San Antonio .....	29 27	98 28	701	1849	1901	31	28.41	
Waco .....	31 35	97 08	424	1867	1901	14	34.80	
Weatherford .....	32 57	97 57	864	1882	1901	8	30.80	

The monthly distribution of precipitation at Corpus Christi between the years 1887 and 1904, also a summary of the highest, lowest, and mean temperatures during this time, as prepared by Joseph L. Cline, observer of the United States Weather Bureau, are given in the table following.

Monthly and annual precipitation.

Year.	Jan.	Feb.	Mar.	Apr.	May.	June.	July.	Aug.	Sept.	Oct.	Nov.	Dec.	An-nual.
	<i>In.</i>	<i>In.</i>	<i>In.</i>	<i>In.</i>	<i>In.</i>	<i>In.</i>	<i>In.</i>	<i>In.</i>	<i>In.</i>	<i>In.</i>	<i>In.</i>	<i>In.</i>	<i>In.</i>
1887		0.17	1.61	Trace.	1.26	3.80	0.10	2.84	9.24	2.99	0.66	5.07	.....
1888	1.91	3.50	2.99	1.45	8.72	5.46	2.25	2.16	7.25	2.91	8.64	.92	48.16
1889	5.47	3.61	3.24	1.06	4.21	2.96	.50	3.00	12.69	.48	3.91	.14	41.27
1890	3.84	2.01	1.67	1.36	2.40	3.22	.99	1.81	1.07	2.47	.37	1.80	23.01
1891	2.85	1.31	2.18	2.14	3.38	1.68	1.57	6.31	4.65	.12	2.53	.91	25.63
1892	1.14	1.09	1.10	.28	1.95	.62	1.15	2.78	2.04	1.23	5.55	1.70	20.61
1893	5.91	6.27	1.10	.42	3.32	1.27	.49	.06	1.14	.25	1.28	.07	20.50
1894	1.59	1.59	.66	5.10	1.63	1.23	4.87	7.65	3.00	.14	.01	.64	28.11
1895	.31	3.49	1.43	2.41	5.67	3.80	.00	1.17	1.68	1.08	4.14	.64	25.72
1896	2.41	2.20	6.2	1.60	1.94	2.19	2.38	5.3	4.39	4.12	.30	.73	23.41
1897	2.57	.06	1.61	.83	2.28	1.81	.00	3.24	.98	3.79	.11	1.08	18.36
1898	.69	1.00	2.74	2.41	1.83	2.44	.43	Trace	2.33	.51	3.61	1.33	19.32
1899	2.36	1.08	.29	3.04	1.16	4.07	.43	.00	2.48	7.34	2.84	1.87	26.96
1900	2.42	1.10	2.32	2.07	2.74	.77	5.85	5.48	2.13	2.01	.25	2.16	29.30
1901	.75	1.33	.07	.45	1.89	1.00	1.30	2.53	7.15	.42	.66	.45	17.50
1902	2.14	2.07	.18	.41	3.05	1.44	.49	Trace	3.63	1.93	3.91	2.34	21.59
1903	1.16	5.81	7.69	.84	2.25	6.48	6.87	1.84	.89	1.74	.56	.79	36.92
1904	.20	1.37											
Averages	2.22	2.11	1.80	1.52	2.70	2.60	1.75	2.44	3.38	1.97	2.31	1.33	26.68

Summary of temperature at Corpus Christi, Tex., 1887-1904.

Temperature.	Jan.	Feb.	Mar.	Apr.	May.	June.	July.	Aug.	Sept.	Oct.	Nov.	Dec.	An-nual.
	<i>°F.</i>	<i>°F.</i>	<i>°F.</i>	<i>°F.</i>	<i>°F.</i>	<i>°F.</i>	<i>°F.</i>	<i>°F.</i>	<i>°F.</i>	<i>°F.</i>	<i>°F.</i>	<i>°F.</i>	<i>°F.</i>
Mean	55.9	58.1	63.9	70.5	75.8	80.1	81.9	81.9	79.1	72.9	64.1	57.9	70.2
Highest	84	88	96	92	96	97	98	98	97	91	89	86	98
Lowest	16	11	28	44	44	49	68	65	54	42	30	20	11

Similar data for Brownsville between the years 1850 and 1891 are given in the following table:

Rainfall at Brownsville (Fort Brown), Tex.

Year.	Jan.	Feb.	Mar.	Apr.	May.	June.	July.	Aug.	Sept.	Oct.	Nov.	Dec.	An-nual.
	<i>In.</i>	<i>In.</i>	<i>In.</i>	<i>In.</i>	<i>In.</i>	<i>In.</i>	<i>In.</i>	<i>In.</i>	<i>In.</i>	<i>In.</i>	<i>In.</i>	<i>In.</i>	<i>In.</i>
1850	4.30	3.80	2.30	0.05	2.20	0.06	1.16	0.01	0.25	5.79	0.69	0.15	20.76
1851	.95	1.20	.40	1.15	.90	2.35	3.65	1.80	5.60	4.10	3.90	4.70	29.80
1852	.50	.60	.35	.00	4.05	5.05	.70	3.90	8.50	4.95	.90	.00	29.50
1853	.00	1.60	.00	2.20	1.10	1.70	.00	3.10	8.00	7.75	1.30	.65	26.40
1854	.45	1.50	1.15	.05	4.10	7.65	4.25	5.00	11.31	5.79	7.47	1.88	50.00
1855	3.47	4.85	3.03	.00	1.92	10.47	7.58	9.52	9.44	5.77	3.85	.92	60.80
1856	3.18	1.80	1.50	.88	2.05	3.25	1.90	.58	3.25	5.75	1.45	.55	26.14
1857	.10	.35	2.30	1.15	.00	.50	3.25	.65	4.65	4.65	.55	2.55	20.70
1858	1.50	.85	.07	.00	1.00	5.15	.70	2.45	5.77	2.75	.45	3.67	24.36
1859					.05	.00	.19	8.00	9.07	.57	.15	2.23	.....
1860								2.46	10.50	1.29	.10		.....
1870	1.60	.00	.00	.90	.00	1.00	.75	.10	2.53	1.00	.70	.30	8.88
1871	.90	.00	.30	1.0	3.40	.78	.40	1.40	2.80	8.50	1.77	.05	20.40
1872	.05	.00	1.64	.82	.27	1.78	1.92	4.19	4.56	3.61	1.60	1.92	22.62
1873	.00	.15	.47	.59	.96	.43	1.10	1.98	15.35	2.81	1.71	2.10	27.45
1874	.86	1.48	1.90	.30	1.34	1.50	2.81	.30	10.96	.48	4.76	.16	26.85
1875	.56	3.72	1.62	.05	1.45	.16	.40	2.25	4.20	5.20	2.35	.10	17.35
1876	.10	1.03	.98	.00	4.36	1.26	2.10	.97	8.85	.22	2.43	3.51	25.81
1877	1.27	7.99	.51	.14	1.05	.95	.90	1.52	.69	3.33	1.21	6.62	25.86
1878	3.67	.63	4.15	1.25	2.96	7.4	6.58	7.20	5.21	8.66	1.76	1.34	36.35
1879	1.03	1.03	.33	1.57	.05	2.55	1.59	9.48	11.64	4.70	.14	6.42	34.73
1880	3.87	1.06	.58	.01	1.56	1.03	3.64	16.58	1.90	3.82	3.44	.58	38.07
1881	2.73	1.18	.20	.30	3.43	Trace	1.49	3.01	5.02	8.72	3.74	1.92	31.74
1882	2.95	1.24	3.54	1.63	7.07	1.69	7.0	2.21	2.68	3.19	3.28	2.38	32.56
1883	1.22	1.01	.63	3.38	.83	5.66	4.02	1.97	7.74	1.65	3.32	2.59	31.62
1884	1.10	Trace	.07	.57	5.86	2.74	.22	.88	8.96	15.71	3.46	1.33	40.91
1885	3.87	2.52	1.54	.67	7.17	.51	.22	2.06	3.55	8.27	.20	1.20	31.83
1886	1.81	2.33	1.15	.17	6.57	7.78	4.88	-3.08	30.77	.55	.48	.69	60.06
1887	.22	.68	2.87	.07	3.94	13.80	3.33	1.45	15.65	16.27	1.70	4.89	59.87
1888	1.98	1.09	2.31	4.79	1.77	2.95	1.30	.95	7.47	2.05	4.99	.93	32.58
1889	2.72	3.27	3.61	2.69	1.26	4.43	5.30	7.03	7.44	.20	1.44	.02	34.61
1890	.69	1.23	1.14	5.48	3.33	2.32	3.97	1.51	1.51	3.67	1.32	.38	25.55
1891	1.65	.78	1.70	2.36	.29	.00	3.00	2.47					.....
Mean	1.59	1.61	1.32	.93	2.42	2.91	2.04	3.36	7.30	4.35	2.06	1.64	31.52



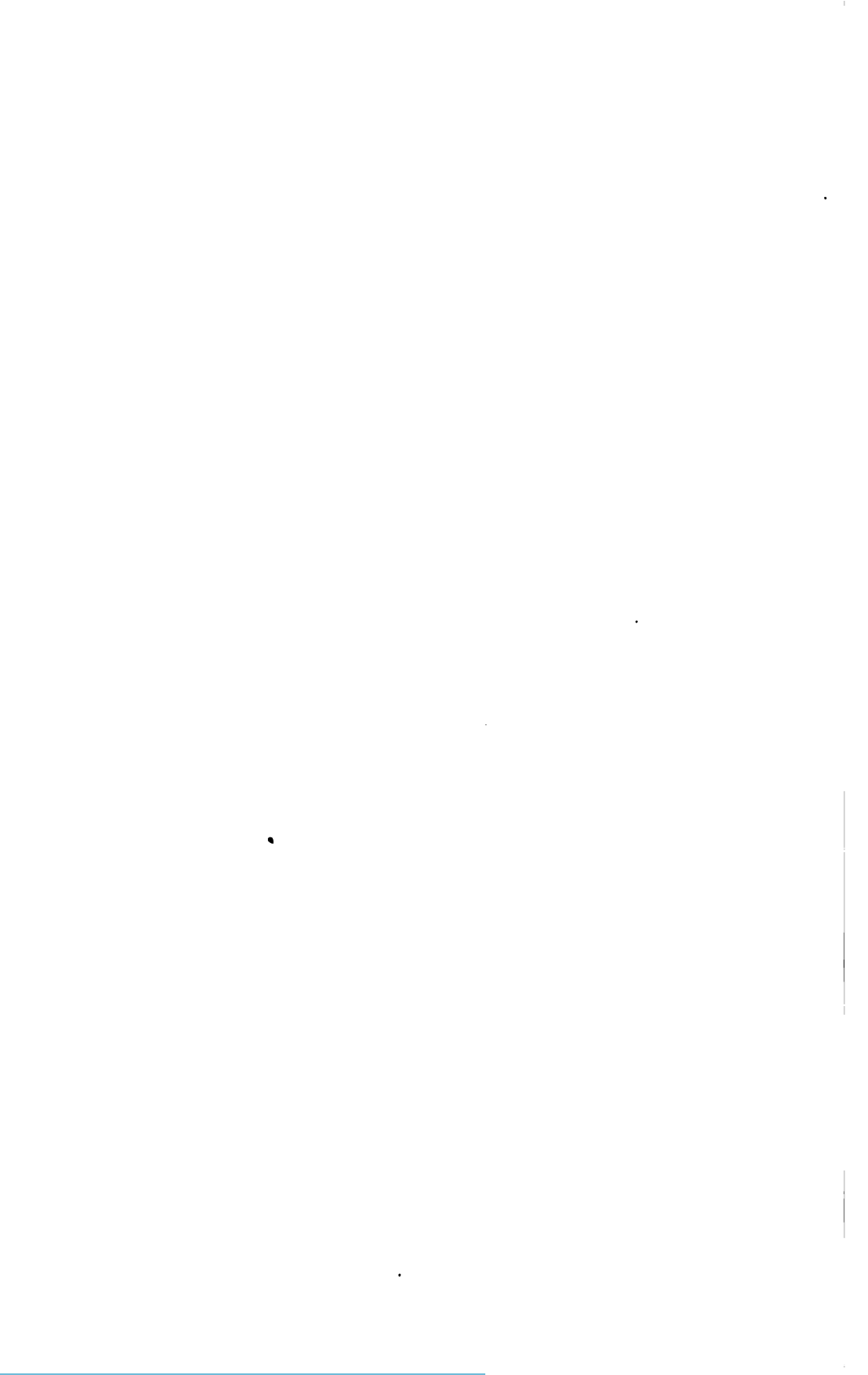

Figure 44 (p. 319) is a map of Texas showing the general distribution of the rainfall and giving mean average values of the same for the different districts into which the State is divided. The rainfall is heaviest in the coastal country, particularly toward the eastern part of the State, whereas in the western part it is comparatively light. At Galveston the average rainfall is about 48 inches per year, while at El Paso it is less than 9 inches.

From an irrigation standpoint the State may be divided into three parts: (1) the eastern part where there is ample rainfall for crops without any necessity for irrigation; (2) a large portion of the central and southern parts which may be called semiarid, where irrigation is a decided aid though not a necessity, and (3) the western or arid portion where irrigation becomes almost necessary.

As will be seen from the tables the rainfall is very uncertain in its distribution. Although in many places the annual rainfall is sufficiently great for the needs of the land, still, owing to this uncertainty, irrigation becomes of great advantage. Besides increasing the value of crops even in good years, the insurance against failure of a crop is a matter of the highest importance and any additional outlay for irrigation is usually considered as money spent to good advantage. The results from the Beeville Experiment Station show most strikingly the advantages which are to be derived from suitable irrigation of land in comparison with land relying upon the rainfall. They show also the comparatively small additional cost for irrigation and greatly increased returns. (See pp. 404-406.) While irrigation was practiced for many years by the Spaniards in Texas, still it is only within the last few years that capital has been invested in enterprises of this nature.

#### USES OF LAND AND ACREAGE.

For a number of years Texas has been essentially a cattle country, and as it is now the cattle business may be regarded as the most important in the State. Cattle men figure that it takes 10 to 15—usually 15—acres of land per head of cattle with wild feed. On such a basis it is apparent that when land becomes of value some more profitable use must be made of it than raising cattle. Some of the more progressive of the cattle men have already realized the possibilities of irrigation and have invested considerable money in such work. Among the majority of them, however, there is a strong tendency to be backward in this respect and a diffidence about entering a field with which they are not familiar.

As an industry, cotton growing is second in importance to cattle raising. Enormous acreages are devoted to it. Being what is usually considered a dry-weather crop, requiring little moisture, it has been grown successfully for a number of years in many parts of the

country. The ravages of the boll weevil in the past year, however, have done almost incalculable harm to the cotton crop and this pest is rapidly spreading over the whole State. The necessity of finding some more remunerative use for the land is in consequence just beginning to be felt.

The following is an estimate made by a cotton grower of the cost of growing cotton per acre:

Rent .....	\$4.00
Plowing .....	1.00
Planting .....	.50
Four cultivations.....	3.00
Two hoeings .....	1.25
Total .....	9.75

For land yielding one-third of a bale to the acre, the following additional charges should be made per acre:

Gathering .....	\$3.33
Ginning .....	.83
Loss in wrapping.....	.45
Total .....	4.61
Cost per acre.....	14.36
Cost per bale of 500 pounds .....	43.08

One thousand pounds of seed per bale obtained from the gin brings \$5 to \$8. At this rate of yield of one-third of a bale per acre cotton, selling at \$40 per bale, would hardly pay expenses. Obviously the greater part of the expenses shown here is independent of the yield. In order to obtain the best results and make a commercial success, larger yields must be obtained. The importance and beneficial results of irrigation are at once apparent in attaining this end.

The following is an estimate of the cost per acre of farming unirrigated corn land:

Plowing .....	\$1.00
Rent .....	4.00
Planting .....	.50
Three cultivations .....	2.25
Total .....	7.75

In order to raise crops which are a financial success, irrigation in the greater part of the State may be said to be almost a necessity. Of the lands in smaller holdings which are irrigated at present, the greater part are devoted to truck raising. Alfalfa has been raised to only a very limited extent, and will bring on an average about \$15 a ton. Corn is quite extensively grown, and generally without irrigation. The yield of corn is not at all what might be expected, and more careful farming and proper irrigation should make a great increase in the output. Sorghum is another crop raised extensively; ribbon cane,

however, is grown to a rather limited extent. Johnson grass is raised in many places for hay. It causes a great deal of trouble throughout the country, being most difficult to keep out of the fields.

From a financial standpoint remarkable returns have been made from growing Bermuda onions, which is a comparatively new industry in Texas. The yields due to intensive farming have been exceedingly large, and the profits have seldom been equaled in farming. On one 40-acre patch \$27,000 was realized for a year's crop; on another 13-acre patch, \$9,000. It must not, however, be assumed that these figures represent average conditions or that such enormous profits can continue. Onions are rather an expensive crop to grow; still, owing to the success of the last year much new capital is being invested in this industry.

Land has increased in value at a remarkable rate in many parts of Texas, solely owing to the benefits and possibilities of irrigation. Land which a few years ago could be bought for almost nothing is to-day selling at \$15 to \$20 an acre. This is the condition at present existing along the lower Rio Grande. The opening up of that section of country by irrigation has led to two lines of railroad being built—one which runs from Robstown to Brownsville, 160 miles, and the other, the "Sap," has already been built from Alice to Falfurrias, a distance of some 40 miles, with the intention of continuing to Brownsville, although work on the same has been temporarily suspended. Property on the Mexican side of the Rio Grande has also advanced very materially, and in all probability a line of railroad will soon connect Matamoras with Monterey. Brownsville, a city of some 6,000 inhabitants, which has hitherto been practically cut off from communication with the outside world, being thirty-six hours' stage ride to the nearest railroad station, is now in a state of boom. The effects of irrigation here have been far reaching, and by no means has growth in values been confined to land alone.

#### GENERAL TOPOGRAPHY.

South and southeast of the Southern Pacific Railroad, between Del Rio and San Antonio, most of the land is of a gently rolling character, flattening out as the coast is approached. (See map, Pl. V.) Within 20 to 50 miles of the Gulf coast the land is generally level, and hence is most suitable for irrigation on a large scale. Mesquite, which is the principal wood in this section, is found in almost every part of the country. It is principally used for fuel owing to the small size and crooked shape of the trees.

The country north of the Southern Pacific, near Uvalde, gradually rises to the mountains which start in the southern part of Uvalde County. The valleys of the Rio Grande and of the Guadalupe



River, near the coast, are the largest irrigation fields at present developed. Further inland the valleys grow narrow and the irrigable territory lies in smaller areas.

### SOIL.

It is not uncommon to find almost every known class of soil within a very small area. There is, however, an unusually large percentage of rich black soil throughout the country, particularly where it has been enriched for years by leaf-loam. In the valley of the Rio Grande the soil is largely alluvial, composed of deposits formed by the river, which has evidently changed its channel many times. The large irrigation field of this river extends from about 75 miles upstream down nearly to the coast. The land near the coast is strongly alkaline, although it loses this quality to a considerable extent farther upstream. Some degree of apprehension has been felt over the possible effect this might have upon vegetation. The deposit formed by the river is widely varying in character, depending upon the part of the country from which the river water has come. The soil tends to crack open when it dries and requires a large amount of water for irrigation, having no impervious substrata within easy reach. Going north from the river everywhere within 100 miles of its mouth the soil suddenly changes from alluvial to a black sandy loam covered with a heavier growth of mesquite, showing quite clearly the demarcation of the land which has evidently not been under water for a long period. This land is at present practically uncultivated save for a few scattered farms owned chiefly by Mexicans. No attempts at irrigation have been made, the land nearer the river receiving first attention. At the time the writer passed through this country, about the 1st of June, all the corn, which is the principal crop, was burning up for lack of water.

North of this belt of black sand land, which is some 20 to 30 miles broad, the soil changes to sand. The mesquite disappears and the only timber to be seen is scattered groups of oak trees. This character of land continues for some 50 miles and extends back some 60 miles from the coast. North of this the land changes to a black waxy and black sandy character, with a fairly dense growth of mesquite.

### WATER SUPPLY.

#### RIVERS.

The Guadalupe and Rio Grande are the main rivers in the territory under consideration which may be relied upon for irrigation throughout the year. The Guadalupe River is regarded as one of the best streams in Texas for a continuous supply of water. Above

Cuero it has a drainage area of about 5,000 square miles. One of its main tributaries is the Comal River at New Braunfels, which is fed entirely by springs about a mile distant from the point where it flows into the Guadalupe. The San Marcos River, which flows into the Guadalupe below New Braunfels, is also one of its large tributaries. At Cuero the river is dammed to obtain power for an electric station which will be described later. The flow at this point when the river was exceptionally low has been estimated at 550 cubic feet per second.

The Rio Grande is subject to very sudden changes in volume and discharge, changing from a few thousand to 40,000 or more cubic feet per second and back to where it started within a very few days. According to Mr. Mendiola, engineer of the Mexican Government, from observations made near Brownsville, while the minimum flow of the Rio Grande is 1,100 cubic feet per second, the maximum discharge is 36,000 feet per second. Under the latter conditions the elevation of the surface of the river above tide water is 45 feet. The maximum surface velocity is 6.3 feet per second. The corresponding discharge of solid matter as measured by Mr. Mendiola is 538 cubic feet per second, being about 1.5 per cent. While the water was comparatively free from sediment near the surface, near the bottom it was practically running mud. The midstream discharge was 7,900 cubic feet per second and the solid matter discharged was 42.5 cubic feet per second, slightly over 0.5 per cent. During these conditions the elevation of surface of the river was 36 feet and the maximum surface velocity was 3.4 feet per second. The average ground elevation near Brownsville is 42.7 feet, the ground being highest at the bank.

The Nueces River is one of the largest streams in this section of the country. It rises in Edwards County in the mountains and flows in a southeasterly direction into Corpus Christi Bay. It drains an immense section of country, but, in spite of this fact, during the dry season there is very little, if any, water to be obtained from the river. There is always considerable flow in the river in the mountain district which becomes particularly apparent where the bed rock is near the surface and the natural flow consequently makes its appearance. The channel of the river through the mountains is filled with rock and bowlders many feet deep. At one place on the river south of Montell in Uvalde County, where in all probability the larger part of the flow came to the surface, a measurement of the water made by the writer the latter part of August, 1904, showed a flow of 35 cubic feet per second. At the point where the measurement was made there was also undoubtedly considerable underflow. Farther down the stream the water disappears entirely in the bed of bowlders. At numerous points along the Nueces River irrigation plants are located

using small quantities of water, but without storage it would be unsafe to go into irrigation on a large scale, depending upon such a supply.

The Frio River has its source in Edwards County and flows southwest into the Nueces. This, like the Nueces, has also a flow of water the year round in the mountains, although the flow usually disappears farther down, except in time of wet weather.

From an irrigation standpoint the river next in importance is the San Antonio, which has its source a short distance above the city of San Antonio and flows in a southeasterly direction into San Antonio Bay. Its headwaters are supplied by springs which evidently derive their supply from the same source as the artesian wells near San Antonio, since the flow of the river has decreased materially since these wells have been put down. The San Antonio River receives a considerable increase of flow from the creeks running into it, as well as from springs and seepage from the banks. A few irrigation plants are also located along the Leona River, as well as along several of the other smaller creeks and streams.

#### LAKES.

Lakes are not numerous throughout the country, the chain of lakes through Zavalla and Dimmit counties being the most important in that part of the State. These are, however, of comparatively small capacity and will be discussed later.

#### WELLS.

The wells in the neighborhood of San Antonio are among the best in existence, the water being found as a rule in caverns in the rocks. The flow from the wells is limited only by the friction in the casing, and is hardly affected by friction in the ground itself. The strata of water-bearing sand generally found in other parts of the district in question as a rule offer considerable resistance to the flow of water, owing to the fineness of the sand. The majority of the wells throughout the State obtain their water from strata of sand, though in many cases water is also found in the porous sand rock, where the flow is generally not great. Very few strata of good coarse sand and water-bearing gravel are found. However, some of the country in Uvalde County, where the various rivers issue from the mountains, has good indications of considerable possibilities in the way of pumped wells. The water flowing near the heads of these streams sinks into the ground farther on, apparently flowing through strata of coarse gravel, which would furnish an excellent supply for wells. As yet almost nothing has been done to develop this supply. The water-works well near Uvalde is an excellent indication of the possibilities in this direction.

Many strata of salt and alkaline water are encountered in well-boring which would be totally unfit for irrigation purposes. The general slope of the country is southeast toward the Gulf, and the water strata also slope in the same direction, being on a steeper grade than the surface of the land. The result of this is that in order to tap the same stratum of water the nearer the coast the deeper are the wells, but at the same time the greater are the possibilities of obtaining an artesian flow. Alkaline artesian water has been obtained in many places, but owing to this quality the wells have been abandoned. The artesian district in Texas is unusually large and a great deal of money has been invested in boring wells in attempting to find artesian water. There seems to be a remarkable fascination about the idea of obtaining water in this manner without pumping. While of course this is highly desirable, still the fact should not be lost sight of that it would be well to investigate the possibilities of obtaining good pumped water, and further, that the expense of an artesian well, usually great, may not justify the expenditure where the flow is small.

#### ARTESIAN DISTRICTS.

There are four distinct artesian districts already discovered in southwestern Texas: (1) San Antonio and vicinity; (2) King, Kennedy, Armstrong, and Lasater ranches; (3) Carizzo Springs district, and (4) wells near Inez and in the country near Port Lavaca.

The artesian field near San Antonio has rather a limited area, but from the water-supply standpoint is superior to any of the others. A 12-inch well bored by the waterworks at San Antonio delivered 6,000,000 gallons per day at the ground level. A static pressure of 40 feet in this well was all used up in overcoming friction in the 600 to 800 feet of casing, according to both figures and actual measurements, as will be described later. Mr. Judson of the San Antonio waterworks devised a unique and interesting method of measuring the flow of water in this well. A bottle containing an aniline dye had attached to its stopper a dynamite cartridge which could be set off by electricity. This was placed a given distance down the well and touched off. The explosion blew the stopper out of the bottle, liberating the aniline dye, which then was carried up by the stream of water. Time was taken by a stop watch and the period which elapsed between the firing of the cartridge and the appearance of the dye at the surface was noted. The length and size of pipe being known, the velocity of the water and hence the rate of flow was determined.

Some of the wells near San Antonio are situated at too high a level to flow without pumping. The static level of the water in the ground appears to be practically uniform for the artesian area, which in

itself indicates that there must be very free and open communication in the underground passages through which the water flows. The depth of the cavities in which the water is found in the rock varies from 6 inches to 13 feet. Some of the wells, however, which are bored where the rock strata are more dense, obtain their water from the porous formation of rock, and the flow into these is of course limited, owing to the friction in the ground.

The most extensive artesian belt in Texas is found in the lower portion of Nueces County and in the northern parts of Cameron, Hidalgo, and Starr counties. The known artesian territory runs about 100 miles north and south and 50 miles east and west, starting about 19 miles south of Alice and running practically to the coast. No artesian water has been obtained at Alice, the elevation being too high. About 19 miles south of Alice the first artesian wells are to be found. These, however, are of small flow, owing to the low head. Going farther south the wells increase considerably in their flow as the level of the land falls off. Wells in this district are usually started with about 6-inch or  $5\frac{3}{16}$ -inch casing, and will vary in flow from 50 to 300 gallons per minute, and are 100 to 1,500 feet deep. Artesian water is found in fine brown sand beds, varying in thickness from a few feet to 40 feet.

The Carrizo Springs artesian district is 32 miles long by 8 miles wide, running northwest and southeast. The wells in the southeasterly part have the greater capacity and are deeper, varying in depth from 300 to 800 feet. The casing is  $5\frac{3}{8}$  inches to 10 inches in diameter at the start. The average flow will vary from 40 to 300 gallons per minute, only about two wells in this part of the country exceeding this limit.

Near Inez, on the Keeran ranch, there are several small artesian wells, from which flow can be obtained at a depth of 50 to 300 feet. About Edna and Louise there has been considerable development in artesian wells, but this is outside the scope of these investigations. Artesian wells of limited capacity are also to be found in the northern part of Refugio County. At Encinal, Laselle County, artesian wells have been put down, which, however, have very small output. Near Pleasanton there is also a small artesian belt.

#### SPRINGS.

The headwaters of San Antonio River have their sources in springs. In the city of San Antonio are also the San Pedro springs, which supply water to an irrigation ditch. The springs of the Comal River at New Braunfels have already been mentioned. Some of the largest springs in this district are near Del Rio. The water from these is utilized for irrigation by the Del Rio Irrigation Company. One of the springs has a flow of about 40,000 gallons per minute and

another about 15,000 gallons per minute. Two miles west of Del Rio are also the Cienegas springs, with a capacity of 2,500 gallons per minute. Some distance to the east of Del Rio, on the Southern Pacific road, are also other springs owned by the Del Rio Irrigation Company, which supply water to Pinto and Sycamore creeks.

#### DAMS.

Very little has been done as yet with the storage of water by dams. Numerous small dirt dams have been erected in the past to store water for cattle, but, being provided with insufficient spillways, most of them have washed out. There are only two dams of any importance for irrigation purposes, one of which is near Port Lavaca, owned by Ross Clark, and an earth dam about 0.5 mile long and 8 feet high, details of which will be given later (p. 383). This was first laid out with a spillway which consisted of merely a cut in the clay bank. A heavy rain cut this out so badly that all the water retained by the dam was lost. After this experience the cut was filled in with earth and a wooden spillway arranged in the center of the long embankment. This dam is thrown across the mouth of a draw, and receives its water from rainfall alone.

The other dam is on the Nueces River, near Carrizo Springs, and was constructed by J. S. Taylor. It is a rock-filled crib dam with earth backing, which raises the water 28 feet, and serves in part for storage and in part for elevating the water sufficiently to irrigate the land without pumping. (See p. 456.)

There are several places where dams could be constructed to excellent advantage to catch the run-off from the land. The rainfall is sufficiently great to be made of much benefit in this manner, as a fairly large annual average can be safely relied upon. However, one of the most important considerations in the erection of dams is the provision of an ample spillway, the necessity for which is particularly brought out by the heavy rains which are liable to occur. Many schemes have been made for the construction of shallow reservoirs in certain parts of the country where the high rate of evaporation in the summer months would of necessity preclude their construction.

#### METHOD OF BORING WELLS.

Hydraulic rigs are greatly in favor for well boring in Nueces County and in the country farther south, where the strata are for the most part soft and little rock is encountered. Considerable speed may be obtained with the hydraulic rigs now in use, and wells are put down at very moderate cost. The method generally employed is to use a straight bit, which will bore a hole slightly larger than the casing, the bit being driven by about a 2-inch pipe. Attached to the

upper end of this pipe is a swivel joint. The weight of the bit and drill pipe are taken in part by ball bearings supported from above. The pipe terminates near the bit in two small holes, each of which is pointed, so that a stream of water which is forced down the pipe will play on the cutting edge of the bit. A pump supplies a constant stream of water to the well through the drill pipe. The same water is caught again where it overflows the top of the well and used continuously for pumping. In order to prevent caving of the sand beds through which the wells pass, this water is saturated with clay and penetrates a considerable distance into the water strata, thus walling them off and preventing undue leakage of the water which is pumped down the well. It is customary to raise the drill pipe a few feet at night on ceasing work. Unlike many systems of well boring, it is not necessary to continue work day and night. A pressure gauge is attached to the supply pipe leading to the drill pipe, indicating the water pressure therein. By the way in which the drill turns, as well as by the sudden change in water pressure in the gauge, the driller can tell when he strikes artesian water. After the completion of the hole the casing is let down, and usually a strainer of some kind is afterwards put down through the casing. With a 6-inch well in the ordinary strata encountered, sand and clay, a crew can make from 20 to 40 feet of hole per day of twelve hours. The log of the well is told in part by the material brought up by the clay water and in part by the movements of the drill rod. However, when a well gets to be of any material depth it is usually a matter of fifteen minutes to half an hour before the material from the bottom is carried up by the water, and this, coupled with the fact that it is mixed in with the heavy clay water, would be apt to place some doubt on the results obtained. This method of drilling, while applicable to soft strata, is entirely unsuited where much rock is encountered. In other sections of the country the ordinary drop drill is commonly used, together with a sand pump for removing the débris.

Still another method of drilling is to put a heavy steel shoe with saw teeth on the bottom of the casing, which itself is revolved. Water is forced down the casing through a swivel joint and comes up on the outside, carrying the cuttings with it. This has been used successfully where very hard rock formations have been encountered, but is rather an expensive method.

#### STRAINERS.

The following strainers have been used in wells: The most common sort is a piece of pipe of a size to fit inside the casing, 20 to 30 feet long with one-half inch or three-eighths inch holes drilled in the part penetrating the water-bearing stratum (fig. 49). The holes are usually spaced about 2 or 3 inches apart in the circumference of the

pipe and from 6 inches to 1 foot between the rows of holes. The bottom of this strainer is landed in clay at the lower side of the water-bearing stratum and the top projects up into the casing of the well. Sometimes the space between the casing and the strainer is plugged up, but usually this is not done. The idea of putting in a strainer smaller than the well is in order to pull it out should it become stopped up. As a matter of fact, it is apt to be quite difficult to do this, and consequently the result is mainly to restrict the area of the pipe and cause additional resistance to the entrance of water. Many of these strainers were originally covered with thin copper gauze over the holes. This, however, was not usually successful, the gauze being very weak mechanically and apt to stop up.

Strainers of the kind referred to above can not properly be classed as strainers and the well will partake more of the nature of an open-bottom well. Obviously, with one-half or three-eighths inch holes no strainer action against sand will be possible. The sand will fill up the lower part of the casing and the water will issue into the casing through the upper holes only, the velocity through the lower holes being insufficient to carry the sand off.

Some wells in Nueces County were put down without strainers, and, as a general rule, although the bed of clay above the artesian sand was exceedingly thick, yet the clay was of such poor quality or else the casing of the wells were put down in such a way that caving ensued and the wells became more or less plugged up. This is not the universal experience, however, in that section of country and may be attributed to the fact that the casing was stopped at the wrong point, being too low down in the water-bearing stratum, instead of being stopped at the surface of the same. The result of this would be that the well would throw an enormous amount of sand and there would be increased possibility of caving. This may be seen by reference to figures 50 and 51, in which figure 50 represents a well casing stopping at the top of the stratum, showing the pool which will form underneath in the sand, and figure 51 represents a well with the casing too far down, showing the large amount of sand which must

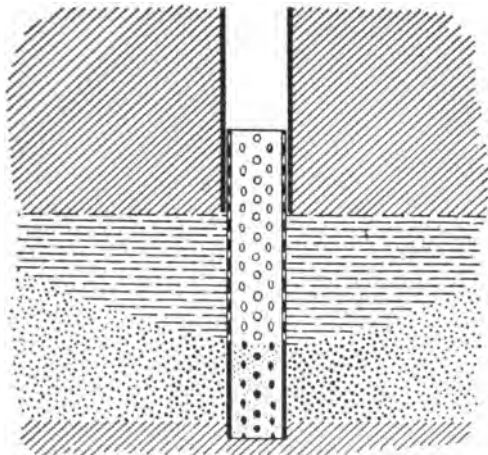

FIG. 49.—Strainer with holes, showing lower part filled with sand.



be thrown out in the natural course of the flow of the well. Figure 49 represents the conditions of the strainers above mentioned, showing the method in which the bottom would fill up with sand and merely the top holes be useful for admitting water to the casing. Of course, were the clay to cave there would be more possibility of stopping up the bottom of the casing itself if small than numerous small holes

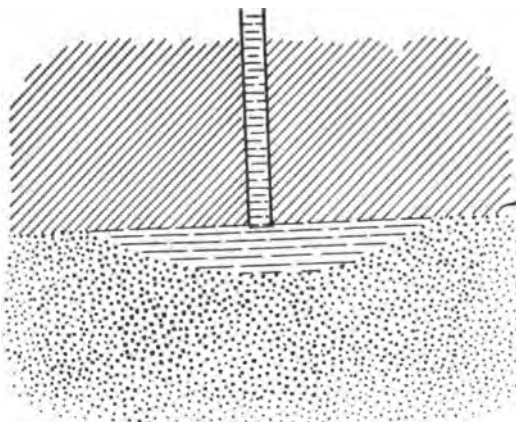

FIG. 50.—Open-bottom well properly put down.

inside, some of which would still throw water, but the fact remains that the use of this kind of strainer is not more liable to prevent caving than the use of open-bottom wells properly installed, although it may prevent the total plugging up of the well in event of caving. It would certainly be advisable to put more holes in these strainers, especially near the top

of the water-bearing stratum, in order to cause less throttling to the entrance of water. Strainers have been used to a limited extent which have been made up in the following manner: A piece of pipe was drilled with many small holes, and copper wire was then wrapped tightly around it, the convolution being wound as close as possible and soldered in four or five places on the outside circumference in lines parallel to the axis of the pipe, as shown in figure 52. The use of these strainers, it is claimed, gave good results.

Another form of strainer was made by utilizing a similar piece of pipe with drilled holes. Copper wire was then wrapped around the pipe, leaving an interval between the convolutions, and over this brass wire gauze was used which was soldered in a similar manner in longitudinal rows (see fig. 53). This is also said to be effective.

A new form of strainer recently brought out is made by taking a joint of pipe, drilling holes in the same, and wrapping the pipe with special copper wire of trapezoidal shape, as in figure 54. A small space is left between the convolutions of the wire, which is soldered

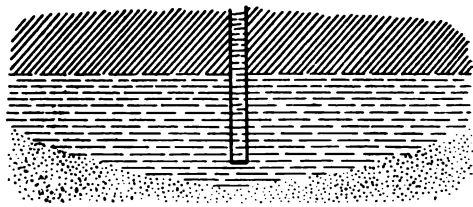

FIG. 51.—Open-bottom well improperly put down.

in longitudinal rows to give it increased strength. The wire is wound with the shorter leg of the trapezoid inside and the longer leg outside, the result being a taper opening for the water to pass through, so that particles which start to go into the casing will, in all probability, continue through. This appears to be founded on the correct principle, although its practical use will have to be judged by experience.

There are certain points which should be combined in a successful strainer as follows:

(1) It should be of such mechanical strength that it will not be injured in being put down the well or by possible action of the water on the same.

(2) It should have openings which increase in size toward the inside of the strainer in order that particles of dirt which start through the opening will be carried all the way through and will not plug up the holes.

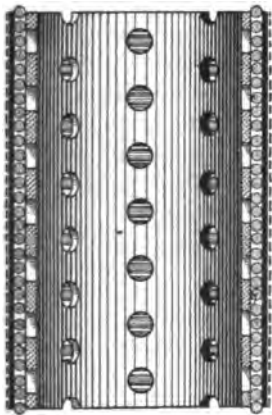

Fig. 58.—Strainer covered with copper wire and gauze.

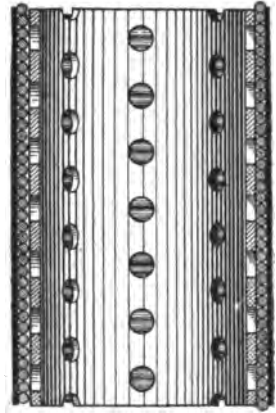
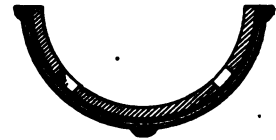

Fig. 52.—Strainer covered with copper wire.



(3) While its openings should be of sufficient size to admit the water, still they should keep out the sand, or at least allow a sufficient quantity of

the coarser sand to work around the strainer to serve as an adjunct to the strainer itself.

(4) It should present as little resistance as possible to the entrance of water. In order for this condition to be fulfilled the strainer should of course be of as large a diameter and as long as possible. The resistance to the flow of water from the well is what limits the output of the well, be it artesian or pumped. This resistance is made up in part of friction in the pipe, which can be figured from the length of the casing; in part of friction in the entrance to the casing, and in part of friction in the ground leading to the casing.

The first is dependent upon the size of well used; the second on the strainer and the diameter and length thereof, as well as on the nature of the ground immediately surrounding the same, and the third on the quality and thickness of the water-bearing

strata. The coarser the sand and gravel the greater the ease with which the water will be transmitted and the better the indications for wells, other conditions remaining the same.

#### COST OF BORING.

The cost of well boring in Nueces County, where the strata are soft and hydraulic rigs are used, is about \$1 per foot without casing, for 6-inch wells up to 1,000 feet. In the vicinity of San Antonio 12-inch wells up to about the same limit cost about \$7 per foot, casing included. In Refugio County, where the strata are exceedingly hard and hydraulic rigs which revolve in the casing are used, the cost is about \$1 per inch diameter per foot up to 1,000 feet. Thus, a 12-inch well would cost complete about \$12 a foot, including casing. In many parts of the country 6-inch wells are bored for about 50 cents a foot up to 100 feet.

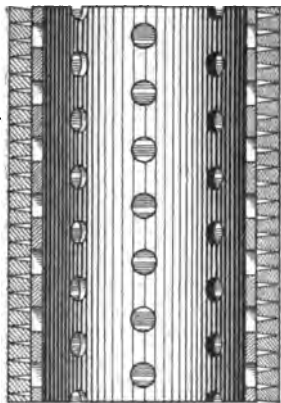

FIG. 54.—Strainer covered with trapezoidal wire.

In sinking a deep artesian well it is almost universally the case that many strata pervious to water are passed through. In some of these the hydrostatic pressure will be insufficient to cause the wells to flow, and hence, provided a free passage is formed between strata of different pressure or between a pervious stratum which has no water and another stratum wherein the water stands above the level of the pervious stratum, there will be, of course, a flow from the stratum of higher hydrostatic head into the other stratum. Provided the hydrostatic head of highest value is reduced by flow down to the head of other strata in connection, there would be no exchange of water. Provided the hydrostatic head of highest water pressure is lowered

still further, water will flow into the well from the other strata, which here will become useful in supplying water to the well, whereas in the first case considered they would be of a decided disadvantage because of the leakage of water between strata, which is consequently lost. This exchange or leakage of water between strata of different pressures is apt to be a matter of considerable moment in case of wells. Provided the hydraulic level of the water entering the well is above the hydraulic level of various strata encountered, then it is obviously important to cut off both from the well casing and from communication outside the casing all strata with too low hydrostatic pressure. The most effective and in fact prob-

ably the only way to accomplish this result is to make sure that the well casing has a water-tight joint between itself and the ground in such a way as to shut off all undesirable strata. It is perhaps an open question as to how much the clay or other strata in a well will close in around the casing if the same has been loosely set therein. Provided there were no constant flow of water tending to keep the channel open between the casing and the clay, the latter would undoubtedly sooner or later settle in and make an absolutely tight joint. But with considerable pressure difference between two connecting water strata it is quite possible that there may be considerable leakage of water which will keep up continuously. As evidence bearing on this question may be mentioned the fact that in the oil fields in various parts of the country many of the wells have been ruined by leakage of water into the oil owing to the drillers not having landed the casing properly and shut off communication between different strata. Nor is this action apt to be confined to one well. There are cases on record where entire fields have been greatly damaged by wells badly put down, the leakage of water into the oil of one well coming up in other wells. That this same thing will occur in artesian wells, causing possibly serious loss of water, there can be little room to doubt. The quantitative value, however, is a thing which there is little means of judging. Suppose the hydrostatic pressure in the artesian stratum is sufficient to elevate the water 10 feet above the ground level and that the water pressure due to some of the strata through which the well has to pass is such that the water stands 50 feet below the ground surface. Then there would be 60 feet difference of pressure, with the well shut off, between the two water strata, water tending to cause the artesian stratum to flow into the other. With the well flowing, if indeed it did flow, owing to the loss of water in the ground not being too great, suppose that 5 feet static pressure are necessary to account for the flow in the well pipe and into the casing and that the other 5 feet pressure are lost in the ground due to friction of the water flowing to supply the well and the leakage. Then there will still be a difference of 55 feet static pressure, tending to cause an exchange of water between the artesian and the other water-bearing stratum. It would certainly appear that this had a fair chance of keeping the channel open on the outside of the casing and preventing the clay closing in around it, as it should do in order to get full benefit from the well and cut off the harmful effects of leakage. It has been reported to be the experience in many parts of Nueces County that the closing down of wells by throttling or shutting off entirely the supply, if continued for any length of time, will diminish the quantity of water which the well is capable of throwing when opened wide. This may be due either to settlement of the sand in the bottom of the well or possibly to changes in the strata through

which the water is passing, due to decreased flow, or else the increased pressure at the bottom of the well will cause an enlargement of the leakage area on the outside of the casing. In fact, in certain wells in Texas which have only limited pressure to cause artesian flow, when the well is shut off the water will follow up the casing and even appear on the outside at the surface. In view of these facts it is certainly advisable to use precautions to make a tight joint between the casing and the sides of the well hole. In the country near Carizzo Springs, where a considerable quantity of rock is encountered in the wells, cement has been occasionally used for this purpose, being put down between the well hole and casing. Some precaution of this kind is practically necessary in order to prevent leakage where there is no clay in the well which would make a tight joint with the casing.

The supply of artesian water, like the supply of surface water, is of course limited in quantity, and there is every reason why proper precaution should be taken to prevent undue loss and to draw therefrom only what is needed. It is perhaps useless to talk economy until the necessity for the same begins to be felt, but the fact remains that it is a matter of public interest to take some means to throttle or shut off the water from wells when the full supply is not needed. The increased demand on the ground supply due to the growing number of wells will sooner or later have its effect on the hydrostatic pressure, and hence on the quantity of water available.

### FUEL.

The fuels available in southwestern Texas are coal, oil, mesquite, and oak. Of these, mesquite is the most widely used for irrigation pumping. Roughly speaking, the fuel value of dry wood is proportional to its weight. The moisture in the wood, however, which may form a large percentage of its weight, is detrimental to its fuel value. Mesquite, according to figures of the Brownsville Land and Irrigation Company, weighs 3,700 pounds per cord. This weight was obtained from a cord closely stacked, a condition which may be regarded as not usually adhered to. Mesquite is so plentiful that the supply for the operation of a pumping station is commonly obtained from the land of the owner, in which case the cost of same is figured merely as the cost of cutting and hauling. A large supply is obtained from clearing and grubbing the land, some parts of the country yielding about 10 cords to the acre. In the valley of Guadalupe River considerable bottom oak is used for fuel. This wood is regarded as inferior to mesquite.

In the territory investigated oil was used only to a limited extent, the principal companies using it being the Victoria Land and Irrigation Company and the Ross Clark plant, near Port Lavaca. Even in

the vicinity of San Antonio the use of fuel oil is limited. The water-works station there recently changed from oil and returned to the use of coal. The Beaumont and Saur Lake districts are the principal oil fields of the State. The price of oil at the wells has been subject to wide fluctuations, varying from 8 to 80 cents a barrel.

Most of the Texas coal is of the lignite variety and of low thermal efficiency. The table below gives cost and efficiency of several of the grades of coal commonly used in the State. The British thermal units per pound of fuel represent the total heat units available from perfect combustion in that quantity of fuel. However, perfect combustion is never obtained, and consequently considerable heat goes to waste. The practical efficiency of a fuel depends on the amount of heat which the boiler is able to extract from a pound of fuel, and this in turn depends on the completeness of the combustion and on the various other factors involving boiler efficiency. The commercial efficiency is not proportional to the British thermal units per pound, owing largely to the variation in the percentages of complete combustion. The degree to which the latter is attained is largely dependent upon making the construction of the boiler suitable to fuel that is to be burned.

In the table the relative boiler efficiency represents the relative efficiencies of various fuels when burnt under a boiler in quantities sufficient to supply an equal number of theoretical heat units. These values, and also the relative fuel values, by weight, are based on the use of fuel for the boilers of locomotives. From what has been said upon this subject, evidently these quantities are approximate, depending on the type of boiler employed, but they still serve as a guide in the selection of fuel. If the plant to be operated is of considerable size the saving in labor of firemen by the use of oil is a point worthy of consideration.

Mesquite makes a very hot fire, and unless proper precautions are taken in the designing of a fire box it is liable to reduce the life of the boiler considerably.

## Cost and fuel value of coal.

Location of mine.	Quality.	Kind.	Cost at mine per ton.	Analysis of fuel.					Calorific value.	Relative calorific value per pound.	Relative boiler efficiency.	Weights of equal fuel values.
				Fixed carbon.	Volatle matter.	Sulphur.	Moisture.	Ash.				
				P. ct.	P. ct.	P. ct.	P. ct.	P. ct.	B. T. U. per lb.	P. ct.	P. ct.	Tons.
McAlester, Ind. T.	Bituminous.	Lump	\$1.85									
		M. R. <sup>a</sup>	1.65	57	37	1 to 2	1 to 2	4	13,700	100	100	1.00
Lehigh, Ind. T.	do	Slack	1.10									
		Lump	1.85									
Thurber, Tex.	Lignite.	M. R.	1.65	40	40	4.5	3 to 4	13	11,900	87	86	1.33
		Slack	1.10									
New Mexico Eagle Pass, Tex.	do	Lump	2.25									
		M. R.	1.00									
McDade, Tex.	do	Slack	2.05	57	32	1 to 2	1	9				1.33
		Lump	2.25									
Calvert, Tex.	do	M. R.	1.50	(c)	(c)	(c)	(c)	(c)				
		Slack	1.50	42	35	10	4	9	10,300	75	80	1.67
Rockdale, Tex.	do		90-1.00									2.00
Lytic, Tex.	do			37	37	1	18	7	6,200	45		
Carr	do			19	60		13	8	4,800	35		
Laredo, Tex.	do			37	41	1	13	8	6,900	50		
				39	51	1	2	7	8,500	62		

<sup>a</sup> M. R.—Mine run.<sup>b</sup> At El Paso.<sup>c</sup> No analysis obtainable; about same as Thurber.

Beaumont crude oil at the wells has sold for 8 to 80 cents per barrel of 42 gallons (310 pounds per barrel), the present price being 45 to 55 cents per barrel. Analysis of same shows 84.6 per cent carbon, 10.9 per cent hydrogen, 1.6 per cent sulphur, 2.9 per cent oxygen. The calorific value, B. T. U., per pound is 19,100. The relative calorific value per pound referred to McAlester coal is 1.39 per cent. The relative boiler efficiency is 1.32 per cent. Three and one-half barrels of oil are considered the equivalent of 1 ton McAlester coal.

Mesquite and oak are the principal woods for fuel. They cost 60 cents to \$2.50 per cord. Oak weighs 3,500 pounds per cord and mesquite 3,000 to 3,700 pounds, depending upon the moisture, the size of the timber, and the closeness with which it is stacked. The calorific value of these woods is about 4,500 B. T. U. per pound. The relative calorific value compared with McAlester coal is 33 per cent. The relative boiler efficiency is 58 per cent. Three cords of oak and 2.8 to 3.5 cords of mesquite are considered equivalent to 1 ton McAlester coal.

The following table gives present freight rates on fuel in Texas as established by the railroad commission. The rates on coal are per ton of 2,000 pounds; on wood, per cord, and on oil, per barrel of 42 gallons, weight 310 pounds, oil being assumed to be 7.4 pounds per gallon. The rates are all for carload lots. The minimum carload of coal is 20 tons; of wood, 30-foot cars 8 cords, 32-foot cars 9 cords, 34-foot

cars 10 cords, over 34-foot cars 12 cords; of oil over broad-gauge roads, 123 barrels. Two classes of rates are given. No. 1 applies to shipments transported over a single line of railroad or over two or more lines of railroad under the same management and control. No. 2 applies to shipments transported over two or more lines of railroad which are not under the same management and control.

Table of freight rates.

Kind of fuel.	Distance and rate.									
	6 miles.		10 miles.		30 miles.		100 miles.		200 miles.	
	Rate 1.	Rate 2.	Rate 1.	Rate 2.	Rate 1.	Rate 2.	Rate 1.	Rate 2.	Rate 1.	Rate 2.
Soft coal except slack, smithing coal, and coke.....					\$0.55	\$0.70	\$0.90	\$1.05	\$1.40	\$1.55
Anthracite.....					.605	.77	.99	1.155	1.54	1.705
Slack coal.....					.40	.55	.75	.90	1.25	1.40
Lignite and lignite briquettes.....					.32	.47	.60	.75	.91	1.06
Wood.....			\$0.50	\$0.90	.70	1.05	1.25	1.40	1.80	1.95
Oil.....	\$0.0775	\$0.124	.093	.14	.14	.186	.217	.263	.279	.31

Kind of fuel.	Distance and rate.									
	300 miles.		400 miles.		500 miles.		600 miles.		700 miles.	
	Rate 1.	Rate 2.	Rate 1.	Rate 2.	Rate 1.	Rate 2.	Rate 1.	Rate 2.	Rate 1.	Rate 2.
Soft coal except slack, smithing coal, and coke.....	\$1.90	\$2.05	\$2.27	\$2.37	\$2.67	\$2.77	\$3.10	\$3.20	\$3.60	\$3.70
Anthracite.....	2.09	2.255	2.497	2.607	2.937	3.047	3.41	3.52	3.96	4.07
Slack coal.....	1.75	1.90	2.17	2.27	2.57	2.67	3.00	3.10	3.50	3.60
Lignite and lignite briquettes.....	1.23	1.38	1.54	1.64	1.86	1.96	2.17	2.27	2.29	2.39
Wood.....	2.50	2.70	3.25	3.30	3.75	3.75	4.00	4.00	4.00	4.00
Oil.....	.356	.356	.418	.418	.48	.511	.511	.511	.511	.511

In addition to the rates quoted in the table, the following are a few special carload rates per ton of coal:

Eagle Pass to El Paso.....	\$2.25
Eagle Pass to Saguin.....	1.00
Eagle Pass to San Antonio.....	.90
Hartz to San Antonio.....	.80
Minera and Cannel to San Antonio.....	.90
Minera and Cannel to Laredo.....	.85
Rio Bravo mines to San Antonio.....	.80
Dolchburg (Rio Bravo) and Hartz mines to Eagle Pass.....	.20
Lytle to San Antonio.....	.30



Rates on coal change every 10 miles of haul, the rate quoted for 30 miles being the minimum. The rate on oil between Beaumont and Galveston is 18.6 cents per barrel. Special rates per cord on wood are as follows:

Galveston, Houston, and San Antonio road, Pierson and intermediate points to San Antonio (except where mileage rates are less).....	\$1.00
San Antonio and Aransas Pass road:	
Serbin, Winchester, West Point, Rock Island, Cheetham, Sublime, and Dilworth, Lockhart, and intermediate points to San Antonio.....	1.50
Cheetham and intermediate points to Corpus Christi (except where mileage rates are less).....	1.50
Altair to San Antonio.....	1.50

The freight rate on coal from McAlester, Ind. T., to Denison, Tex., is 90 cents per ton. From Lehigh, Ind. T., to Denison, Tex., the rate is 70 cents per ton.

Rates on wood are made for 10, 15, and 20 miles; then every 10 miles up to 100; then every 20 miles up to 300; then every 30 miles up to 400; then every 50 miles up to 500. Rates on oil are quoted for 6, 10, 15, and 20 miles; then every 10 miles up to 60; then every 20 miles up to 100; then every 25 miles up to 250; then every 50 miles up to 550.

### WATER CONDUITS IN USE.

The majority of the canals in use in Texas, particularly the large ones, are built exceedingly wide for the depth. The earth which forms the banks of the canal when same is not in a cut is usually taken from borrow pits. Sometimes, as in the case of the Brownsville Land and Irrigation Company, these borrow pits are on the inside of the canal. (See p. 441.) As is seen, the dirt is not taken from the entire bottom, which hence presents additional surface for friction to flowing water. Of course, in the course of time these borrow pits will fill up with sediment. In several other plants, however, large borrow pits have been made on the outside of the canal, either for dirt to form the banks or to raise the grade of the canal. This is a practice which is usually to be condemned, as much valuable land is wasted thereby in addition to rendering the land impassable for vehicles, except in certain places, although this latter consideration is possibly of secondary importance. In one instance which the writer recalls there was a space fully 50 feet wide on each side of the canal absolutely ruined in this way. If the dirt for the construction of the ditch had been obtained by going back some distance from the ditch and taking a uniform layer off the ground, instead of taking it all out in a lump, this land would have been as good as ever and a

considerable saving would have been made. Moreover, it presents a most unattractive appearance to see the land all cut up in this way, though perhaps this is not as appealing to most people as the idea of pecuniary loss.

The work of irrigation in many parts of this country is comparatively new, and many people entering the field have had no experience before in work of this nature. As a consequence, many of the canals are constructed with exceedingly weak banks, coming almost to a point on top, with the water level entirely too close to the top of the bank for safety. These are continually breaking and causing a large amount of trouble and expense. It is poor policy to put in work in this manner. A ditch should always be constructed with the banks amply wide and a safe distance between the water level and the top of the canal bank. These are things, however, which will, of course, come in time and with experience. Canals should be built on such a slope as to give sufficiently high velocity to the water to prevent the accumulation of sediment and the tendency to plant growth. At the same time the velocity should not be high enough to cut. About 2.5 feet per second is usually considered a good velocity for flow. There is a natural tendency with beginners in irrigation to attempt to make the slope of banks entirely too steep. Of course, the slope which can be given depends largely upon the nature of the ground, and in the softer earths 2 to 1 on the outside and 3 to 1 on the inside may usually be regarded as about as steep as good practice will permit. The result of using a steeper slope, particularly on the inside, is that caving will ensue from the wash of water.

#### WOODEN FLUMES.

Wooden flumes are not much used in this country, as there is very little demand for them, owing to the level nature of the ground. Their principal use has been in conveying water from the pump stations to the canals, where some form of conduit was necessary. Even here more expensive earth fills have frequently been made to avoid the trouble of building and maintaining flumes. There are several cases where more careful selections of sites for pump stations would have been of material benefit in the construction of the canal system and would have avoided the use of either wooden flumes or expensive fills. These flumes are always a source of more or less trouble and of high depreciation, particularly where they are alternately wet and dry, in which case it is very difficult to keep them tight. In some instances they are being lined with tin or galvanized iron to make them watertight. This should give good results and will doubtless be well worth the additional expense.

There is great variation in the timber frames supporting the flumes, some having many times the requisite amount of material and others being so light that the flumes seem to be in imminent danger of collapse. It should be borne in mind that if a flume is to remain water-tight it should be well supported, in order that the spring of the timbers may not cause a leak.

**WOODEN PIPE.**

No wooden pipe whatever is in use in this region. It would certainly pay irrigators to investigate this subject in connection with plants where the quantity of water delivered is large. For handling

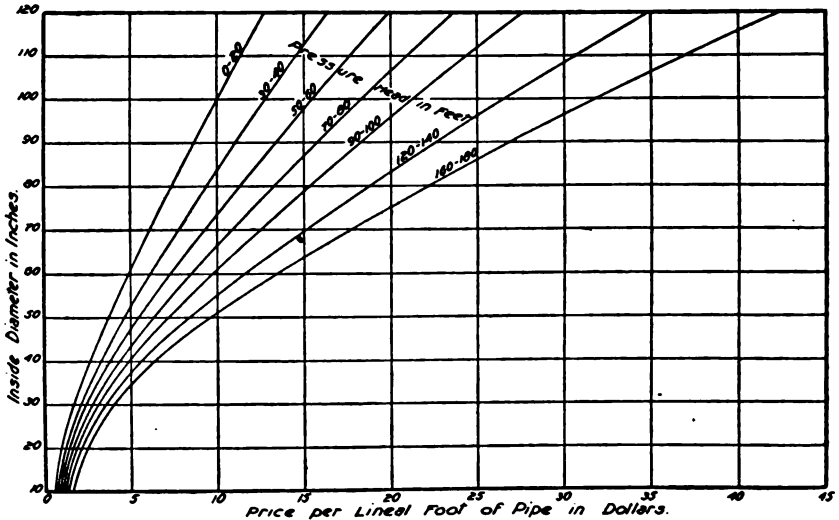

FIG. 55.—Cost of wooden stave pipe.

small quantities of water it is of course out of the question. Even though more expensive, it would be advisable in many instances to install stations with pipe leading from pumping stations to the ditch rather than to use the flume construction now practiced. The pipe for this purpose should of course be sufficiently large to obviate the friction loss of head and could be made of steel or wood, depending upon the size of the pipe.

The following table represents the approximate cost of redwood-stave pipe in Texas (figs. 55 and 56). Wooden pipe built of pine could be constructed for about one-third less than the figures given below :

*Cost of redwood stave pipe in Texas.*

Pressure heads.	Cost per foot of wooden pipe, inside diameter of—											
	10 inches.	20 inches.	30 inches.	40 inches.	50 inches.	60 inches.	70 inches.	80 inches.	90 inches.	100 inches.	110 inches.	120 inches.
<i>Feet.</i>												
0-20	\$0.58	\$0.98	\$1.70	\$2.65	\$3.75	\$4.90	\$6.15	\$7.35	\$8.70	\$10.00	\$11.80	\$12.75
20-30	.65	1.10	1.90	3.00	4.20	5.50	7.00	8.35	9.85	11.30	12.95	14.50
30-40	.72	1.20	2.10	3.25	4.70	6.20	7.75	9.45	11.10	12.80	14.55	16.40
40-50	.79	1.30	2.25	3.50	5.00	6.75	8.50	10.35	12.20	14.20	16.15	18.15
50-60	.86	1.40	2.40	3.80	5.50	7.30	9.30	11.35	13.40	15.50	17.70	20.00
60-70	.93	1.50	2.60	4.10	6.00	8.00	10.15	12.40	14.70	17.00	19.00	22.00
70-80	1.00	1.62	2.75	4.35	6.40	8.50	10.90	13.25	15.70	18.35	21.00	23.70
80-90	1.10	1.74	2.95	4.65	6.75	9.10	11.70	14.30	17.00	19.80	22.70	25.70
90-100	1.21	1.86	3.15	4.95	7.20	9.75	12.50	15.35	18.30	21.30	24.40	27.60
100-120	1.33	1.98	3.35	5.30	7.85	10.75	13.95	17.20	20.50	24.00	27.60	31.30
120-140	1.46	2.14	3.55	5.70	8.50	11.70	15.20	18.40	22.55	26.50	30.75	35.00
140-160	1.59	2.32	3.75	6.00	9.10	12.70	16.55	20.70	24.90	29.30	34.00	39.00
160-180	1.62	2.50	4.00	6.35	9.70	13.50	17.75	22.90	28.80	31.80	37.00	42.50
180-200	1.85	2.70	4.30	6.80	10.30	14.50	19.00	24.90	29.00	34.40	40.00	46.10

Wooden pipe when properly installed is subject to very little depreciation. It should be set in such a manner that the entire inner

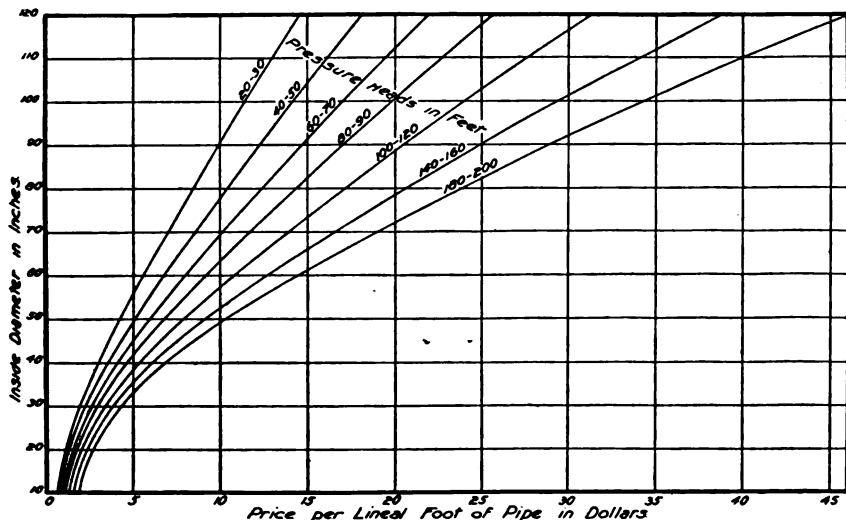

FIG. 58.—Cost of wooden stave pipe.

surface will always be kept wet. Manufacturers of wooden pipe claim that redwood pipe under good conditions should last fifty years and even under quite unfavorable conditions at least twenty-five years. This would give an average annual depreciation rate of 3 per cent. Pipe built of pine is subject to much more rapid depreci-

tion, its life being approximately fifteen years under similar conditions, which would signify a 7 per cent depreciation. Experience with wooden pipe leads to the conclusion that a pipe not buried will last longer than one which is buried only a few inches to a foot below the surface of the ground, due to the action of roots and brush on the wood. The life of pipe may be much prolonged by burying the top at least 5 feet below the surface. Exposed wooden pipe is more liable to damage by fire or maliciously inclined people than were it covered with earth.

One great advantage of wooden pipe over metal is the increased carrying capacity due to the smoothness of the wood. Thus, for example, wooden pipe will carry approximately 16 per cent more water than the same size iron pipe for a given loss of head, owing to the greatly diminished friction.

#### **CONCRETE CONSTRUCTION.**

Concrete construction for conduits for water has been used to a limited extent in Texas. The San Antonio Irrigation Company have a considerable amount of concrete-lined canal for the conveyance of sewage water of the city of San Antonio to the sewage farm. The Del Rio Irrigation Company have made quite extended use of concrete expanded metal pipe, of which an account is given on page 425. They have also built a large amount of ditch in which the outer wall, in steep hillside work, has been largely constructed of concrete, and in the case of fills the entire channel has been lined with concrete.

The cost of expanded metal pipe will depend largely upon local conditions and the question of the use of concrete pipe requires careful consideration of both conditions and the demands of the work as to whether some cheaper form of construction would not answer fully all requirements. For example, wooden pipe could be installed at a lower first cost than concrete expanded metal pipe, but would be subject to higher depreciation. Any settlement of foundation would render the concrete pipe more liable to leak. The question to be determined by the engineer is whether the expense of interest, depreciation, and repairs would be greater or less for wooden than for concrete pipe.

#### **GENERAL CONDITIONS OF LABOR.**

In the southwestern part of Texas labor for farm purposes is unusually cheap, particularly near the Mexican border. The greater part of the labor throughout the country is Mexican. Until recently near Brownsville 50 cents Mexican per day, or 23 cents currency, was the price of Mexican labor, but since then prices have gone up.

With the settlement of the country it is probable that these will increase still further owing to increased demand. Along the Mexican border labor costs 75 cents to \$1 Mexican a day and throughout a large part of the southern country \$1 Mexican is the rate of compensation. Throughout the remainder of the country in question the rate of labor is from 50 cents to \$1 a day in currency, except near the larger cities, where it is from \$1.50 to \$1.75.

Very few negroes are to be found working in the fields here, and negro labor hardly counts at all as a factor. With all his shortcomings, under the present conditions the Mexican is practically a necessity for conducting farm operations in the lower country, and although Mexican labor may not be as efficient as American labor, still, considering the prices paid, there can be little cause for complaint. The clearing of large areas of land covered with brush and trees is often let out to Mexicans by contract at so much an acre. The cost of work of this nature seems exceedingly moderate considering conditions, some of the most heavily timbered land being cleared for from \$10 to \$15 an acre. The fact that from 5 to 10 cords of wood per acre can be obtained from some of this land shows for itself the amount of work which it is necessary to perform.

#### **DETAILED DESCRIPTION OF IRRIGATION PLANTS.**

The data given in the following pages are based largely on information furnished by the owners of irrigation plants. In many places where the plants were not in operation at the time of the visit it was impossible to form any definite idea of the rate of flow of water. As far as possible the flow of wells, pumps, and canals was measured or estimated by the writer. While it is difficult to obtain accurate information on the operation of plants, still it is believed that the descriptions and data of the farms will give, on the whole, a good idea of the present state of irrigation in Texas.

#### **CUERO.**

Cuero, the county seat of Dewitt County, is situated on the bank of the Guadalupe River. There is a limited amount of rich bottom land in this vicinity, which is occasionally flooded by the river at high water, as well as several irrigated farms of a few hundred acres each lying along the banks of the river. Large tracts of irrigable land, however, can not be obtained so far from the coast without involving considerable expense. The irrigated land is of a rich, black, waxy nature. The principal crops are rice, corn, and truck. Water for irrigation is pumped from the river by steam plants, the vertical lift being about 36 feet.

Mr. Otto Buchel has erected a dam across the Guadalupe River, to which reference has already been made. He has installed a water-power station, utilizing a fall of about 12 feet, which is usually obtainable except at times of very high water. The installation in the station consists of three vertical turbines of 225 horsepower each, which drive through bevel gears a line shaft, to which are belted two 2-phase 2,000-volt electric generators. The plant distributes electricity for power and lighting to the town of Cuero, about 2 miles distant, and also furnishes power for driving a cotton mill, as well as an irrigation pumping plant owned by Crouch & Slacker.

In addition to the electric equipment at the station, the following hydraulic equipment is also installed: One 225-horsepower 54-inch new American turbine drives through bevel gears and belting a No. 15 centrifugal pump rated to deliver 7,000 gallons of water per minute at 42-foot lift; a duplex power pump, 18 by 22, driven by water power, delivers 3,500,000 gallons per day when operated at about 25 revolutions per minute. This is equivalent to a flow of, in round numbers, 2,400 gallons per minute. These pumps both discharge water into a reservoir 500 feet square and 7 feet deep, from which, however, only 3 feet in depth of water can be drawn. The centrifugal pump discharges into a flume which empties into the reservoir, while the duplex pump empties directly into the reservoir. The outlet canal from the reservoir is 60 to 90 feet wide and about 7 feet deep, the size, however, varying in different parts, the capacity of the canal being rated at 12,000 gallons per minute.

Mr. Buchel owns 600 acres planted to rice and irrigated from the plant just mentioned. The land is laid out in checks varying in size from 0.5 to 8 acres, the difference in elevation between the checks being 0.4 foot. The land requires 10 gallons per minute per acre. The irrigation season is from April 1 to October 1, or about 120 days. The average yield in 1903 was 11 sacks of 165 pounds each per acre, but in 1904 the owner expected to get 14 sacks per acre.

Water is admitted into the checks by wooden gates and will pass through about six checks in series. Under favorable conditions it is possible to irrigate from one gate 30 acres per day of twelve hours, or in twenty-four hours 50 acres.

*Thomas ranch.*—Mr. Thomas owns 180 acres of rice which he irrigates with a 10-inch Morris double-suction centrifugal pump, rated at 3,000, but said to deliver 4,000 gallons per minute. The lift from the river is 33 feet, and the pump is driven by a 60-horsepower simple noncondensing engine, which consumes 8.5 cords of wood in twenty-four hours. The fuel used is mostly bottom oak and costs \$2 per cord delivered. The average size of the checks is 6 acres, and the plant operates on an average eighteen hours per day for the irriga-

tion season of one hundred days. Corn unirrigated yields 25 bushels per acre.

*Woofort & Rathbone ranch.*—Woofort & Rathbone own a farm of 350 acres on the side of the river opposite to Cuero, a short distance from town, which they planted in rice. They have installed a pumping station with the following apparatus: A 100-horsepower boiler furnishes steam at 100 pounds pressure to a 14 by 18 inch 75-horsepower noncondensing simple engine, which drives a No. 12 centrifugal pump, rated at 5,000 gallons per minute. The plant consumes 2.75 cords of oak in a twelve-hour run, the lift of the water being 33 feet. The rice irrigation season lasts for one hundred and twenty days, for several plantings of rice, and usually the plant is operated twenty-four hours per day. The checks, which vary in size up to 40 acres, are irrigated by passing the water through them in series. The main canal is 40 feet wide and 5 feet deep. The plant started March 21, and requires an average of 2½ men to irrigate the land throughout the season. The average yield is 13 sacks of rice per acre, and the operation of the power plant is conducted by two engineers, one of whom receives \$50 per month and the other \$1.25 per day, and two firemen, one of whom receives \$1 and the other \$1.25, working twelve-hour shifts.

*Davidson & Breeden farm.*—This farm consists of 420 acres, 260 of which are at present under irrigation, being planted to rice. Irrigation on part of the farm starts the last of April and on the other part May 20, and ends September 10. All the land is usually sown by June 1. Rice is cut about September 10. The pump station contains the following equipment: One 125-horsepower boiler supplies steam to a 90-horsepower engine belted to a No. 12 centrifugal pump rated to deliver 6,000 gallons per minute under a maximum lift of 26 feet. The pump is stated to deliver 6,500 gallons per minute. Steam pressure carried is 70 to 80 pounds, and average daily run for the season of one hundred and ten days is twelve hours. The fuel used is box elder, elm, oak, pecan, ash, and hackberry, the plant requiring about 400 cords per year. The fuel is figured to cost \$1.50 per cord, as it is cut on the land of the owners, but were it necessary to buy the same it would cost about \$2.50. The operation of the plant and general superintendence of the ditch require three men—foreman, engineer, and fireman. The foreman receives \$40 a month and the engineer and fireman get \$60 a month together. In addition to this, four men at 75 cents a day are required for irrigation. The owners estimate that they could irrigate 500 acres in rice with the addition of another engineer and fireman to their present force. The average yield per acre is 14 sacks of rice. The engine, according to a test, delivered 98 indicated horsepower. The boiler consumes 3.5



cords of wood in twelve hours. The canal is about 60 feet wide, and varies in depth from 25 feet near the river bank to 6 feet near the other end. Near the power house there is a large fill and in consequence the canal has been made exceedingly deep. The length of the canal is three-fourths of a mile, and it is possible to draw the water down 4 feet. The canal is used in part as a reservoir. The checks vary in size from 5 to 25 acres, the laterals running diagonally across the same. The main ditch cost \$2,300 to construct, at 10 cents per yard, and the contractor lost \$250 on the work on account of bad weather. Water is let into each check from a lateral ditch and then is drained back into the ditch for renewal of the water, because fresh water is regarded as giving better results. It usually takes about twelve hours to flood the checks, and the water seeps and evaporates in the fields 1 to 2 inches per day. In one part of the field, which had been previously used for a wagon road and was much harder than the remainder, the growth of rice was materially stronger than elsewhere and the same beneficial results are obtained in other places where the ground is more compact.

*Crouch & Schleicher farm.*—The Crouch & Schleicher farm consists of 400 acres, 300 of which are planted in rice and 100 in truck. Water is obtained from the river. The pump installation consists of one 100-horsepower 2,000-volt 2-phase motor belted to a 12-inch centrifugal pump. The lift is 46 feet and the rate of flow about 4,000 gallons per minute. The length of run for the rice season is one hundred and twenty days, and the pump is operated twenty-three and one-half hours per day, except Sunday, when it is shut down from 6 to 10 a. m. The pump is said to have been delivering at the time of the writer's visit 4,500 gallons per minute, and it was taking a current of 18 amperes at 2,300 volts. A steam engine had also been provided to take the place of the motor in case anything should happen to the electric power, such as an excessive rise of the river, which would decrease materially the fall at the dam. The boiler consumed 6 cords of bottom wood in twelve hours, but delivered somewhat more water than the motor. The cost of power was three-fourths of a cent per horsepower hour, which is certainly very reasonable considering the conditions, and hence the cost of operation of the electric plant was about \$1 per hour for power. In one hundred and twenty days' season the average pump hours run per day was seventeen. The greater part of the water was used for rice. The checks were of 1 to 15 acres and 0.4 foot difference in elevation. As many as 6 checks were irrigated in series from one gate. The yield of rice was 4,300 sacks on the 300 acres, or 14 sacks per acre, the weight of the sacks being 180 pounds.

The steam plant which was put in to take the place of the electric plant consisted of one 110-horsepower engine and two 70-horsepower

horizontal boilers. The cost of the steam plant was about \$4,000. According to the present method of operation, two men run the motor and pump and four men are required to run the steam engine and boiler. Four irrigators were required to handle the water of the plant. The cost of wood for fuel was about 50 cents per cord for cutting and 25 cents for hauling and would cost about \$2 if purchased from outsiders, but the wood was cut on the land of the company.

Mr. McHenry, who used to be in charge of the Beeville State Experiment Station, has at present taken supervision of the truck farm on this ranch, and the results of the same should be of considerable interest to the truck farmers as illustrating the possibilities of this kind of farming on a large scale. He uses for a fertilizer for onions 100 pounds of bat guano and 500 pounds of acid phosphate per acre, and figures that the cost of the culture of onions per acre is \$27 and the cost of gathering and sacking \$1 per 1,000 pounds. The depth of water per irrigation for truck is 1.5 inches, and one man can irrigate 2.5 acres of truck per day. Cabbage on the ranch requires about three irrigations per year.

#### VICTORIA.

The country in the vicinity of Victoria is very level and offers a good field for irrigation on a large scale. At present there is only one large plant in this vicinity, though there are several plants of a few hundred acres. Rice is the principal crop grown, and the character of the land is almost universally of a black, waxy consistency.

*The Victoria Rice and Irrigation Company.*—The largest irrigation company in this vicinity is the Victoria Rice and Irrigation Company, which irrigates nearly 3,600 acres of land entirely devoted to rice. The pumping plant is situated about 8 miles south of town on the banks of the Guadalupe. In order to lift the water to a sufficient height for irrigation, two pumping stations have been installed, one of which raises the water 20 feet and discharges it into a flume 1,400 feet long, from which the second pumping station takes its water and elevates it 42 feet. The flow of water is estimated, when all machinery is running, at 52,000 gallons per minute. It would surely have been far cheaper to have installed all the apparatus in one power house and to have used a sufficiently large pipe to have conveyed the water to the canal. The double installation and operating expenses both conspire to put a considerable additional burden on the plant.

The equipment of the pumping stations is as follows: The plant near the river has two 16 by 24 engines of 180 horsepower each, belted to a centrifugal pump, 30-inch discharge, of the open-runner type; three 250-horsepower boilers furnish steam for this power. The upper plant contains two Corliss engines of 570 horse-

power each, each of which operates by a rope-drive a centrifugal pump of 30-inch discharge, delivering 26,000 gallons per minute, the pumps being the same as those in the lower power house. These engines were bought secondhand and they leak so badly that, although jet condensers have been installed, it is impossible to operate them on account of the leakage of air. The boiler capacity of the second plant consists of a battery of nine 72-inch by 18-foot horizontal multitubular boilers of 180 horsepower each. One hundred and ten pounds steam pressure is carried. The fuel is Saur Lake oil, which is pumped from the nearest railway station 7 miles distant through a 2-inch pipe. An outside-packed plunger pump is used for this purpose and uses a pressure of 450 pounds to the square inch. This will deliver two cars, or 14,000 gallons, of oil on a twelve-hour run. The pressure, of course, will depend more or less on the temperature of the ground, but fortunately this oil is rather thin and is not affected to anything like the extent of the California oils by the cold. In July the cost of the oil delivered to DeKosta, the nearest railroad station, was 80 cents a barrel of 42 gallons. The fuel consumed by the two plants is about 150 barrels per day on an average, though with continuous running at full capacity about 300 barrels are required in twenty-four hours.

In the year 1904 3,600 acres were planted to rice.

In addition to the land watered by the main and lateral ditches there are 300 acres lying above the available water supply, which are furnished with water by a Menge pump driven by a traction engine and lifting 9,000 gallons per minute  $4\frac{1}{2}$  feet. The engine is 18 horsepower and runs in the daytime only. The main canal of the company is 100 feet wide by 3 feet deep, not counting the borrow pits which are on the inside. It costs about \$1.25 per acre to disk and plow waxy land. One man irrigates about 25 acres a day, and the plant is of sufficient capacity to irrigate 5,000 acres if desired. Five thousand three hundred acres are owned by the company, but not all under cultivation. The checks are laid out 3 to 25 acres in size. The total yield of rice was 48,000 bags of 180 pounds each, or 13.3 bags per acre. The company furnishes water to the customers for one-fifth of the crop and rents land under the same terms.

*McKoy ranch.*—Situated a few miles to the northeast of the Victoria property is the ranch of Mr. McKoy, on which two well-pumping stations have been installed. The owner intends to raise alfalfa and expects to get ample supply from wells to make this venture a financial success. The first vein of water in the wells is at a depth of 36 feet. At 45 to 50 feet there is a stronger vein, from which the water rises to the 36-foot level, as also at 65 and at 80 to 100 feet. The last-named stratum is composed of gravel and the upper water strata

are of sand. The first stratum is about 3 to 5 feet thick; the second, 7 to 8; the third, 8 to 12, and the fourth, 3 to 10 feet. The pumping plant had been recently installed. In pump station No. 1 was a No. 5 centrifugal pump set at a depth of 36 feet, driven by a 50-horsepower engine, which drew the water down 22 feet and delivered a flow of 600 gallons per minute. In plant No. 2 was a No. 6 centrifugal pump, also set in a pit 6 feet square and 36 feet below the ground, driven by a 35-horsepower traction engine. The well for this plant was 90 feet deep and water was found, for the most part, in gravel between 79 and 90 feet. A 12-inch strainer 42 feet long was put in the well. The water was drawn down to 60 feet from the surface when delivering a flow of 500 gallons per minute.

*McCan farm.*—Mr. McCan has an irrigated farm within the town limits of Victoria. A 4-horsepower gasoline engine operates a deep-well pump, 6 by 21 inch cylinder, running 30 strokes per minute, delivering water from a well 115 feet deep. The quantity delivered is 70 gallons per minute and the engine consumes 10 gallons of gasoline in twenty-four hours. The cost of gasoline is 18.5 cents per gallon. The pump delivers its waters into a reservoir of about 60 feet bottom diameter by 9.5 feet deep, holding 300,000 gallons. The pump will fill the reservoir in seventy-six hours' continuous run, and, starting with the reservoir full, will irrigate 8 acres in three and one-half days. Water stands 53.5 feet below the ground level without flow, and the suction pipe of the pump is submerged 12 feet under these conditions. The discharge pipe is 9 feet above the ground level. The surface soil is 2 to 3 feet thick, and the ground will yield 5 tons of alfalfa hay in six cuttings. The plant irrigates 20 acres, the land usually receiving three irrigations a year.

*Seligson plant.*—Mr. Seligson has a farm of 50 acres which he irrigated by pumping water from a dug well 6 by 8 feet, 34 feet deep. A 15-horsepower gasoline engine was used to drive a No. 4 centrifugal pump, which lowered the water 5 feet in the well. The water was found in sand and gravel. In the center of this well another well 230 feet deep was put down with 11 $\frac{1}{2}$ -inch casing. Without pumping, the water in the well stood 25 feet from the ground. The cost of gasoline for operating this plant was \$4 for twenty-four hours, the price of gasoline being 18 cents per gallon. Of this farm 40 acres were planted in rice and 10 in truck. The rice irrigation season lasted one hundred days and one man was able to attend to all the work. The gross yield of rice was 80,000 pounds. At \$1.75 per barrel, the price of rice late in the season, this farm was just able to pay expenses.

*Lander & Rathbone place.*—About 4 miles from Victoria is a plant, owned by Lander & Rathbone, irrigating 64 acres. Rice and

corn are the two crops grown, the yield of rice being 18 to 20 barrels per acre. Water is taken from a lake adjoining the field. The owners estimate the size of the lake as follows: Length, 2 miles; average width, 250 yards; average depth, 12 feet. The average lift of water is 12 feet, and it is elevated by a centrifugal pump driven by a 16-horsepower traction engine. The pump delivers 150 gallons per minute. The plant is operated day and night until the land is flooded, and thereafter about ten hours per day, the fuel consumption being 0.08 cord per hour. Rice was planted April 1 and the pumps were started May 15. The length of the irrigation season is ninety days. The operation of the plant required one pump man and one irrigator. The overflow from Guadalupe River helps largely to fill the lake. The centrifugal pump is of the vertical type and is completely submerged. It requires twelve days' continuous running to flood the land thoroughly.

*Davis farm.*—About 8 miles northeast of Victoria is the irrigation plant of Mr. Davis, which consists of three pump stations one-fourth of a mile apart, which irrigate 60 to 75 acres of rice per well. The surface soil is 6 to 10 inches deep, with a clay subsoil. The average yield is 10 sacks per acre, although it was said last year that as much as 18 sacks per acre was produced. The pumping plants are run continuously, two men being required for each plant, as they work twelve-hour shifts. Plant No. 1 was throwing 300 gallons per minute, as estimated by the writer, and consuming 4.5 cords of wood in twenty-four hours; plant No. 2 was not giving more than one-half this amount of water, with the same fuel consumption, and No. 3 was delivering 300 gallons per minute, with a fuel consumption of 3 cords for twenty-four hours. The cost of fuel is \$1.50 per cord. Each pumping plant has a steam engine of 30 horsepower driving a No. 6 vertical centrifugal pump set at the bottom of a pit 30 feet deep. In the bottom of each pit was sunk an open-bottom well with 8-inch casing. The first water-bearing stratum lies between 90 and 120 feet from the surface and is 15 feet thick, consisting of fine sand. At a depth of 270 feet, which is the depth of the wells, there are about 50 feet of the same kind of sand. The water in the wells stands without flow 17 feet from the surface of the ground, and is lowered 20 feet below the level of the pumps. The total lift is about 53 feet. The land is laid off in checks of 2 to 40 acres, with 4-inch differences in level.

*Keeran ranch.*—About 6 miles east of Inez is the ranch of Mr. Keeran. This is at present used as a stock ranch, none of the land being under cultivation. Numerous artesian wells of very shallow depth have been put down on the ranch. The following may be regarded as the average strata encountered near the ranch.

- 6 to 8 feet, soil.
- 10 feet, fine water sand.
- 10 to 50 feet, red clay.
- 20 feet, fine water sand.
- 10 to 50 feet, white clay.
- 20 feet, water sand slightly coarser with black specks.
- 100 feet, indigo-blue clay.
- 20 feet, coarser water sand.
- 100 feet, blue clay.
- 20 feet, light artesian-water sand; better quality has black specks.
- 50 to 200 feet, white clay.
- 20 feet, dirty sand.
- 200 feet, clay.
- 25 to 30 feet, coarse artesian sand with black specks. This artesian stratum in some places has a static pressure of 17 pounds to the square inch.
- 200 feet, blue clay.
- 30 feet, coarse artesian-water sand. Pressure about 20 pounds.

In low places on the ranch artesian water has been obtained at the following depths from the surface, some of the flows being small, however: 17, 50, 127, 130, 114, 148, 202, 222, 425 feet.

All these wells give off an odorless fuel gas. The wells already put down are of small diameter, being designed for stock purposes only, consequently give small flows. The method employed in finishing these wells, which have been put down by hydraulic process, is to support the casing on top and pump clear water for some time down the well and up around the outside of the casing in order to wash the clay out of the sand and set the casing properly. The wells are all open bottom.

Garacitus Creek, which runs through the Keran ranch, carries a considerable quantity of drainage water at the time of rainfall and could be utilized as a reservoir by a dam estimated at 0.75 mile long and 20 feet high, to store water 15 feet deep on 7,000 acres.

*Bennett & West ranch.*—This land, near by, has the following wells:

- 2-inch well, 330 feet deep, delivering 20 gallons per minute.
- 2-inch well, 50 feet deep, delivering 9 gallons per minute.
- 2-inch well, 327 feet deep, delivering 30 gallons per minute.
- Well (12-inch, 300 feet; 9-inch, 390 feet; 6-inch, 210 feet), 900 feet deep, delivering 150 gallons per minute.

*Duesse ranch.*—Within a few miles of the Keeran ranch is that of Mr. Duesse. A well 880 feet deep furnishes artesian water. The well was sunk 515 feet with 5-inch casing and the remaining distance with 2-inch. This well supplies both water and gas and is used mainly for the house of the owner. It has a static head of 28 feet above the ground level without flow and will deliver on the ground 30 gallons per minute. The water from the well goes into an elevated tank, in which is also placed a sheet-metal drum for collecting

the gas, which is piped into the house and used for fuel and lighting. The gas burns with a bluish flame and is used with a Welsbach mantle for light.

*Laughter & Simon ranch.*—About 4 miles north of Mr. Duesse's place is a pumped well which irrigates 150 acres, belonging to Laughter & Simon.

#### CREEKS.

In the country lying along the coast of Texas from Port Lavaca to the mouth of Aransas River there are many creeks and streams emptying into the Gulf which are dry except in times of rain. The run-off of much of this land is relatively large, as there is but little to retain the water. Some of these creek beds and valleys could be dammed to store this water which now runs to waste. Generally speaking, however, such undertakings would require fairly long dams of moderate height, and in order to utilize the water on the land pump stations would have to be installed. As the region is liable to rain storms of occasional severity, it is of first importance to provide ample spillways to take care of the water.

The Clark Irrigation Company near Port Lavaca is the only case of any note in which a dam has been built to utilize water stored in this manner. It has been estimated that its reservoir capacity is 2,000 acres, with an average depth of 12 feet, and the watershed supplying the same 22 by 20 miles. The reservoir is supplied by Placado and Agula creeks. It is claimed that 14,000 acres can be irrigated with this storage. At present 1,300 acres of rice and 200 acres of corn are being irrigated. The latter was irrigated once, and the yield is estimated at 25 bushels per acre. The company have also 300 acres in cotton not irrigated.

From the engineering standpoint, the pumping station is a decided improvement over all the other stations in this part of the country. Two water-tube boilers supply steam at 125 pounds pressure to a cross-compound condensing engine of 250 horsepower, which is direct connected to a 36-inch centrifugal pump. The output of the pump as run at present is 30,000 gallons per minute. This output can be doubled if desired. The station is operated three days a week. The fuel consumption for twelve hours is 8 barrels of oil. Six days' run of twelve hours each are required to keep 1,300 acres flooded. The pumps were run about sixty days during the season. The lift varies from 23 to 31 feet, the average being 29 feet.

The main canal is 60 feet wide and 4 to 11 feet deep. Water is taken into this by a flume 6 feet wide and 3 feet deep, into which the pump discharges. The laterals are run on contours and irrigate by passing the water through several checks. The fields are divided

into checks of various sizes, the largest one being 200 acres. The contour checks are 2 to 9 inches. The checks can be drained by draws, which return the water to the reservoir. Corn is irrigated by furrows 300 to 400 feet long.

The operation of the plant requires one fireman, one engineer for the power house, four irrigators, and four additional men to make necessary repairs to ditches, etc.

In 1903 the average yield of rice was 15 sacks (180 pounds each) per acre, the highest yield being 26 sacks.

The Clark dam is situated a short distance below the junction of Placado and Agula creeks. It is about 0.5 mile long, 4 feet wide on top, front slope 1.5 to 1, and back slope 2 to 1, and is built of dirt. As originally constructed the dam had a wasteway cut in the clay bank near one end which was intended to carry off the surplus water. However, in time of heavy rain this wasteway was cut out and let out all the water that was in the reservoir. After this accident the wasteway was filled up solid and a wooden spillway about 400 feet long made in the center of the dam. The spillway was double boarded on top with 1-inch and 1.5-inch planks and on the downstream side provided with sacks filled with sand for taking the impact of the water and preventing wash. The wings of the dam are made of 2-inch plain sheet piling.

*Big Chocolate Creek.*—It has been claimed that Big Chocolate Creek, which empties into Chocolate Bay a few miles from Port Lavaca, could also be used as a storage basin by putting a dam across the lines of the grade of an old railroad which formerly ran to Indianola.

*Noble & Wilson.*—Noble & Wilson have a pumping plant near the mouth of Lavaca River, from which they irrigate 250 acres of rice.

*O'Connor ranch.*—In the eastern part of Refugio County is the stock ranch of Mr. O'Connor, where several artesian wells have been sunk. Artesian water is obtained at depths of 900 to 1,200 feet in fine sand. The wells are of 7 to 10 inch casing. About 30 feet of fine sand constitutes the main artesian stratum, although small artesian strata may be found higher up. The formation through which the wells pass is very hard and drilling is expensive. The wells have been put down by rotating the casing with a cutting shoe on the end of it and utilizing the hydraulic process for forcing the cuttings up the outside of the casing. The wells are provided with strainers of smaller diameter than the casing, consisting of perforated joints of casing over which is a layer of wire gauze covered in turn by a layer of perforated brass. The cost of these wells was \$1 per foot per 1-inch diameter of casing, with a guaranty to go at least 1,000 feet. They are said to yield 30 to 200 gallons per minute.



Among the other artesian wells and attempts to obtain the same in this vicinity may be mentioned the following:

Waterworks well at Victoria, artesian water 888 and 1,062 feet deep, found in fine sand, giving a flow of 100 gallons per minute.

In Gonzales County, near Pilgrim, a well was put down 1,402 feet without getting water.

At Sinton, on the San Antonio and Aransas Pass Railroad, a well was sunk 1,860 feet for J. J. Welder. While no artesian flow resulted, yet at the 900-foot level a supply of pump water was obtained.

#### SAN ANTONIO.

Irrigation at San Antonio was begun by the Spaniards and mission fathers many years ago, and some of their original ditches are still in use. In the earlier days sufficient water was obtained by gravity from the San Antonio River—which is the main source of supply—to perform all the desired irrigation, but since the discovery of artesian water irrigation has taken on a new aspect and the field for the same has widely increased. Pumping plants have also been installed on many of the wells situated above the level of the water plane, where no artesian water was available, as well as to increase the flow from artesian wells. At many places along the San Antonio River pumping stations of considerable capacity have been installed, increasing greatly in value the land which they irrigate. San Antonio itself, in addition to being the largest city in Texas, is the natural commercial center of a large section of the richest land in the State, much of which is at present in an undeveloped state, and the city is destined to grow considerably with the development of the surrounding country. The most important feature in promoting this result is the irrigation of lands now arid.

The San Antonio River has its source in springs a few miles from the city. There are three ditches which at present derive their water by gravity alone from the river. The Upper Labor takes its water from the river at a point about a mile below its source, on the right bank. This ditch was formerly owned by the city and ran past the International and Great Northern depot, but at present it is owned by 22 truck gardeners, who formed an association and charged \$2 an "hour" three times a month throughout the year for the use of the entire flow. The length of the ditch has been cut down to 3,000 yards. This ditch, which was originally built by the Spaniards many years ago, is 6 feet wide on top and 3.5 feet deep, and water runs about 2 feet deep. It is said to deliver 2,000,000 to 4,000,000 gallons per day.

Within the city limits of San Antonio are the San Pedro Springs, which belong to the city. There are altogether seven springs, five of

which are in rock and two in sand, furnishing a supply of 2,000 gallons per minute. Of this amount one-fourth runs through the town in the lower ditch and goes to waste. One thousand five hundred gallons per minute are used in the San Pedro ditch and a branch ditch, for irrigation, these two dividing the flow between them about evenly. Water is sold in shares known locally as "hours," each of which entitles the purchaser to the entire flow of the ditch for one hour three times a month throughout the year. The annual charge is \$2 per "hour," which is equivalent to \$2 for thirty-six actual hours' flow of the ditch. On the main ditch two hundred and forty-four "hours" of water were sold during 1903 and 274 acres were irrigated; on the branch ditch one hundred and forty-three "hours" of water were sold and 150 acres irrigated.

About 6 miles from San Antonio in the vicinity of the hot springs are the heads of the San Juan and Espado ditches, which are over 150 years old. San Juan ditch is on the east side of the river and is said to have a flow of 4 cubic feet per second. It irrigates 500 acres, thus giving the entire flow one-half hour per acre once every ten days. The ditch was originally 7 miles long, but has been cut down to 3 miles.

Espado ditch, which is on the west side of the river, irrigates 600 acres, the flow of water and conditions being about the same as under the San Juan ditch. The land irrigated by this ditch is all in small holdings and the owners of the land also own the ditch, which was originally 12 miles long but has been cut down to 5 miles.

These two ditches are practically the same size—5 feet wide on top, 4 feet on the bottom, and 3 feet deep, with a grade of 1 foot per mile. Water runs about 1.5 feet deep in the ditches. The flow from these ditches is considered hardly sufficient for the irrigation of the land.

The main crops grown are truck, corn, cotton, ribbon cane, and alfalfa. The bed system is used for the irrigation of cane, alfalfa, and grain, the checks being 10 feet wide and 300 to 600 feet long, with a fall of about 3 inches. The other crops are irrigated by the furrow system. It takes the flow of the ditch one-half hour to irrigate 1.5 acres by the furrow system, while the same length of time will irrigate only 1 acre by flooding. The soil is 1 to 3 feet deep, with clay subsoil. The frequency of irrigation in dry periods with different crops is about as follows:

	Days.
Corn and cotton.....	20-30
Cane.....	10-15
Truck.....	10

Numerous artesian wells in the vicinity of San Antonio derive their supply of water from caverns in the rock at depths of 600 to 800 feet. The underground connection between the different wells appears to

be very free and results in the static pressure being practically equal in wells which are several miles apart. It is commonly supposed, and without doubt is the case, that these artesian wells derive their supply of water from the same strata as the water which forms the San Pedro Springs and the headwaters of San Antonio River.

San Antonio River is said to have fallen very considerably in flow since the numerous wells have been sunk in the surrounding country, and this is commonly attributed to the flow from these wells having diminished the subterranean supply. During the drought of 1898 San Antonio River went entirely dry, for the first time since 1875, and remained so until 1900. In this period the output from the wells decreased considerably.

Among the various wells and irrigation plants in the vicinity of San Antonio may be mentioned the following:

On the river, 2.5 miles north of town, is a farm belonging to the estate of H. B. Kampman, which is leased by Louis Lehr. The Upper Labor ditch runs along the border of the field, which, however, derives its water supply from a 10-inch artesian well 1,020 feet deep. Artesian water is found in a limestone formation. The well is cased for 854 feet, the remainder of the hole being in rock. When first put down the well had a static head of 11 feet above ground level. At present it is said to discharge 700 gallons per minute. During the drought of 1898 the well ceased temporarily to flow. Thirty-five acres are irrigated, but it is considered that the flow of water is hardly sufficient for this area without rain, and that under these conditions the well will irrigate 20 acres of truck. A reservoir which stores twelve hours' flow will, with four hours' additional flow, irrigate 2 acres in four hours by the furrow system. The furrows are 150 yards long, and the time required for the water to run through them is one and one-half to two hours. Mr. Lehr irrigates every ten days in dry weather, and in the summer starts at 5 p. m. to avoid irrigating when the ground is excessively hot.

The city waterworks of San Antonio have three pumping stations which derive their supply from artesian wells, the water being delivered direct into the city mains. In addition, there is a reservoir into which the surplus water from the pumps flows. One of these pumping stations is situated near the head of San Antonio River and utilizes the water power of the river for driving the pumps. The capacity of this station is 3,000,000 gallons per day.

The second station is situated about 2 miles nearer town, on the river, and likewise derives its supply from artesian wells, which, like all the others in the vicinity of San Antonio, are open bottom. At this station there are three 8-inch wells and one 12-inch well 800 feet deep. Water without pumping at present stands 7 feet above the

ground level. When the pumps are running, delivering 3,100 gallons per minute, the static pressure of water will be diminished only 2 or 3 feet. In the year 1900 water stood 18 feet above the ground. The lowest point recorded was 1 foot below the ground level.

The machinery is steam driven, and can also be driven in part by stored water power in the river. It has two vertical 50-horsepower boilers, and supplies steam at 100 pounds' pressure for a 100-horsepower simple Corliss engine, which has a jet gravity condenser giving about 23 inches vacuum. The engine drives two Worthington geared pumps, which supply water under a pressure of 52 pounds. The pumps operate six hours a day. Fuel consumption is 15,000 pounds of Lytle coal per day. The San Antonio River at this station has a fall of 14 feet, which is also utilized in 80 and 50 horsepower turbines for driving the pumps.

The main station of the San Antonio waterworks is also situated on the river, near the center of town. It has four 8-inch and five 12-inch wells 880 feet deep. These are about 20 feet apart. Each is fitted with 650 feet of casing, the remainder of the hole being in rock. The wells are all connected by piping to the suction side of the pumps. In May, 1904, the static head above the ground was 35 feet. One of the 12-inch wells delivered 4,200 gallons per minute. The maximum fluctuation of water level due to drought is 12 feet. The water pressure carried on the mains at this station is 75. pounds. Water is supplied by triple-expansion Worthington duplex pumps, with a steam end of 12, 20, 33 by 24 and a pump end of 18.5 by 24, capacity 5,000,000 gallons per day, and six Gould triple-plunger single-acting pumps, with a total capacity of 5,000,000 gallons per day. Lytle coal, at \$1.60 per ton, is used for fuel. It will evaporate about 3 pounds of water per pound of coal, as against 4 pounds evaporated by Black Diamond coal. Oil cost, delivered in San Antonio, 86 cents per barrel, being 42 cents at the oil wells, 37 cents freight, and 7 cents drayage. The average output of the station was at the rate of 10,000,000 gallons per day, and while delivering this quantity with one of the wells disconnected the static pressure in that well was only 1 foot lower than when the other wells were not flowing at all. The pressure on the suction side of the pumps was 10 pounds positive pressure when delivering this flow, thus showing that the ground pressure was scarcely affected, due to the flow of water pumped from the ground, the principal source of loss being friction in the pipes and well casing.

Adjoining the old station the waterworks have put up a new plant, which is at present in operation, delivering 15,000,000 gallons per day. It consists of a large triple-expansion pumping engine 24, 46, 68 by 42, and three pump cylinders 28.5 by 42, the speed being 28.5 revolutions per minute. The boiler pressure is 150 pounds.

The cost of 10-inch wells in this vicinity 500 to 1,000 feet deep is \$4 to \$4.50 per foot.

The strata have a general southeasterly slope, on a greater grade than the grade of the ground, hence near the headwaters of San Antonio River the wells are more shallow and the water pressure above the ground is less than farther downstream. Near the springs at the head of San Antonio River at the first waterworks station it is only 350 feet to artesian water. At the main waterworks station the following is the log of one of the wells:

Three hundred and fifty feet, blue clay.

One hundred and eighty feet, magnesium limestone—very soft, white.

Three feet, shale and sulphur.

Three hundred and fifty to three hundred and eighty feet, blue, white, and gray limestone.

At a depth of 720 feet there was a stratum, however, of blue mud 50 feet deep.

The following represent average strata encountered in well boring in San Antonio:

	Feet.
Soil .....	3- 4
Yellow clay and gravel .....	60
Blue clay .....	500-700
Blue and gray rock .....	120
Black marl-like lignite clay and rock .....	20- 30
Loam rock .....	60
Blue clay (locally known as a "mudhole") .....	50

Below the mudhole lies a water rock, which is usually blue, yellow, and white. Sometimes a dark brown sand rock is found in which the water supply is plentiful. In the artesian belt water is almost always found within 50 feet of the mudhole. The artesian belt extends fully 16 miles west, 9 miles north, and 6 miles east of the town.

The cost of well boring, furnishing everything complete, is as follows for wells up to 1,500 feet deep:

*Cost of boring wells.*

Diameter.	Boring.	Casing.	Total.
8-inch well .....			
per foot..	\$2.50	\$0.75	\$3.25
8-inch well .....	8.25	1.00	4.25
do.	4.20	1.30	5.50
10-inch well .....	5.30	1.70	7.00
do.			
12-inch well .....			
do.			

At San Louis College, which is somewhat northeast of San Antonio, there is an 8-inch well 713 feet deep, the casing extending down 500 feet. Water is found in rock. The well is open bottom. The college is about 130 feet above San Antonio, and water stands without

flow in this well 80 feet from the surface. A deep-well pump, 5½ by 30, capacity 80 gallons per minute, driven by a 20-horsepower engine, lifts water into a tank 70 feet above the ground. At a depth of between 150 and 200 feet is a water-bearing stratum giving a poor supply of sulphur water. Between 300 and 400 feet a better supply is obtained, but the main water-bearing rock, which is evidently the same stratum as that of the artesian flow in San Antonio, is between 700 and 800 feet deep. The elevation of San Louis is 760 feet above the sea.

Another 8-inch well near by is 705 feet deep and is provided with a 5½ by 19 inch deep-well pump driven by a 25-foot windmill. This is by far the largest windmill in this part of the country. It delivers most of the water at ground level into a tank near by. Under average conditions this windmill will throw a stream of about 40 gallons per minute. The wind in the vicinity of San Antonio averages 6 to 8 miles per hour and is fairly constant. The average velocity, as determined by the Weather Bureau, is 7.4 miles per hour.

Very extensive use of windmills has been made throughout Texas, and in several cases small irrigation plants have been run by the aid of water so pumped. Windmill capacities as usually given by manufacturers are based upon a wind speed of about 15 miles per hour. The energy of the wind which passes a windmill varies as the cube of the velocity of the wind, hence with a wind at half the speed mentioned the power obtained would be greatly reduced. Where wind power is used for pumping for irrigation it would usually pay to install much larger mills than has been the custom.

*Polo ranch.*—A short distance from San Louis College is Captain Tappen's Polo ranch. The irrigated portion of this ranch consists of 86 acres, which is planted mainly in corn. Water for irrigation is supplied by a pumped well tapping the San Antonio artesian stratum. The well is 1,000 feet deep and water stands without flow 76 feet from the surface of the ground. A brick shaft is built down 84 feet below the ground level and in the bottom of this sets a vertical centrifugal pump. A 25-horsepower gasoline engine belted to a countershaft drives this pump, which lifts the water 8 feet above the ground into an outlet box, from which it can be turned either into a flume or into an earth reservoir about 150 feet in diameter and 17 feet deep. This depth is due to excavating material for the banks, and, of course, part of the water stored in the reservoir can not be used for irrigation. The pump discharged 600 gallons per minute by measurement and the engine required 5 gallons of gasoline per hour. The plant would irrigate 6 to 7 acres per day, the length of run being nine hours. Corn was irrigated four times during the past season. The ground is very liable to crack when dry and seemed to have been over-irrigated. The ditches were in poor condition. The land was also

unfavorably situated for irrigation, being quite hilly. Gasoline for the engine cost 12 cents per gallon.

*Vance ranch.*—A few miles from San Louis College is the ranch of Mr. Vance. The house is situated on the top of a hill at an elevation of 804 feet, and near by is a small farm, which is irrigated by water pumped from two wells. Water rises without flow to 145 feet from the ground level. The wells are 6 inches in diameter. One is 160 feet deep and the other 660, but the water supply for both comes from the 160-foot level. In the valleys near by, 100 feet lower, the water stratum is at a depth of 400 feet. Mr. Vance's wells are operated by deep-well pumps, one of which is driven by a 2½-horsepower engine giving 15 gallons per minute, the engine consuming 5 gallons of gasoline in sixteen hours. The other is driven by a 6-horsepower engine giving 35 gallons per minute and consuming 7 gallons of gasoline in fifteen hours. The combined capacity of these wells will irrigate 1.5 acres in three days. The price of gasoline is 17 cents per gallon.

*Creamery Dairy Company.*—South of San Antonio, on the river, near the town limits, is a pump station belonging to this company which has recently been installed. A No. 10 centrifugal pump belted to a 50-horsepower engine pumps water from the river 16.5 feet into a ditch. The pump is intended to irrigate 400 acres of land and has a rated capacity of 5,500 gallons per minute. Lytle coal, costing \$2 per ton delivered, will be used as fuel for the 60-horsepower boiler which furnishes steam for the engine. The ditch for conveying water from the pump to the field is 3 feet wide on the bottom, 6 to 8 feet wide on top, 3 feet deep, and 1.5 miles long. The slope of the ditch is 0.5 inch in 250 feet. The water will be used to irrigate truck, cane, and alfalfa by the furrow system. In the irrigation of alfalfa the furrows will be 5 feet apart. Part of this land was formerly irrigated by sewer water, which is now, however, conveyed several miles below the city and used by another irrigation company.

The intake to the suction pipe is through a channel formed by sheet piling, and the water in the river is backed up by a small dam. When the pump station of the creamery started running it utilized a large part of the water flowing in the river, and will undoubtedly interfere with the users of water farther down the stream.

About a mile farther down the river are two current wheels about 20 feet in diameter, operated by a 3-foot fall in the river. These will deliver a flow of 500 gallons per minute and will irrigate 12 acres in about twelve hours. The construction of these current wheels is shown in figure 57. This water is used to irrigate 100 acres of land owned by Mr. Klein, who is also one of the owners of the creamery company.

*Kellman well.*—Near the “Sap” roundhouse in San Antonio is a tract of 18.5 acres irrigated by the flow of a well on the place of Mr. Kellman. The well is 1,100 feet deep, of 8-inch, 6-inch, and 4.5-inch casing. The flow from this well will irrigate 3.5 acres in twelve hours, and is utilized for irrigating the land owned by Mr. Kellman, as well as that of many of the neighbors near by. The well is said to have a pressure without flow of 25 pounds at the ground level. It has been estimated that the well would irrigate 100 acres of truck with irrigations three to ten days apart.

There are several small irrigation plants along the river which pump water with gasoline engines. West of San Antonio, however, are the largest irrigation plants in that vicinity.

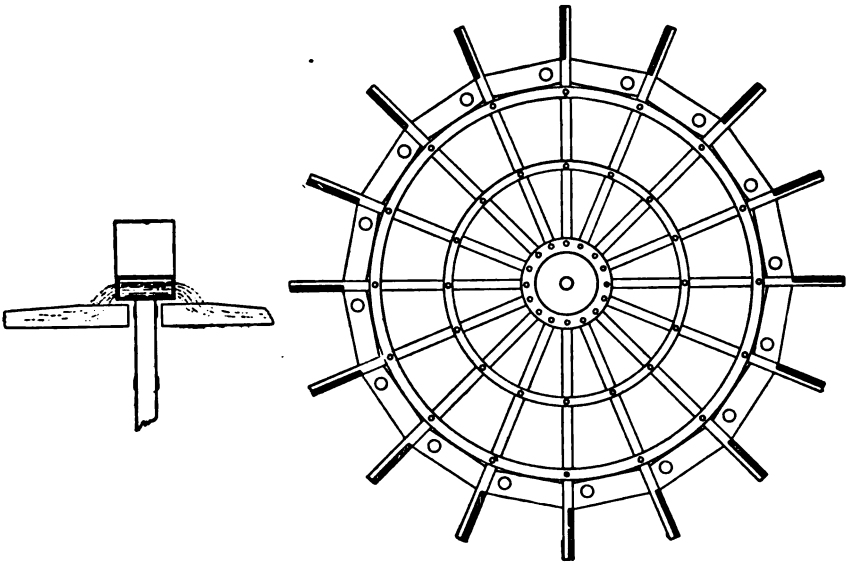

FIG. 57.—Plan of current wheels belonging to Mr. Klein, San Antonio, Tex.

*Collins plant.*—F. F. Collins owns a tract of 180 acres just outside of the town limits of San Antonio which is irrigated by water from two artesian wells. One is 700 feet deep, with 12-inch casing down 500 feet. The other well, near by, is 640 feet deep and has a 10-inch casing. The first well reaches to the artesian water stratum, and the second evidently derives its supply from the same water stratum through the lower 60 feet of hole of the first well, the water then running across between well holes through the intervening strata. From measurements by the writer in September, 1904, the well water without flow stands 17 feet above the ground. The output of the 12-inch well with the other well shut off was 1,080 gallons per minute, whereas the combined output of the two wells was only 60 gallons more, or 1,140 gallons per minute. With both wells flowing, the out-



put of the 12-inch well was very materially reduced over the condition existing when the other well was shut off. The 640-foot well struck water at that level and at first had a flow of 15 gallons per minute from the porous limestone. Eventually the other well broke through into it, greatly increasing its flow. The cost of these wells was about \$5,000 apiece.

Adjoining the wells is an earth reservoir of 3,000,000 gallons capacity, the banks of which are 7 feet above the ground. The reservoir is 1.5 acres in area and 12 feet deep. While this reservoir is kept full, it is never used, as the wells are of ample capacity for the irrigation of the land. The cost of building this reservoir was 11 cents per cubic yard for earth handled. It was made entirely of earth, which is a sticky black soil, and is water-tight.

The land owned by Mr. Collins is divided into 10 and 15 acre tracts, each of which has its house and barn, and improved land is rented out at \$25 per acre per year, all necessary water being supplied tenants.

The main ditch is 6 feet wide on top, 2 feet deep, and has a grade of 8 feet per mile. The laterals run at right angles to the main ditch and have the same slope. The water from the plant is utilized day and night, and allowance made of the entire flow of fifty-five minutes per acre per week. Mr. Collins estimates his wells to be sufficient for the irrigation of 500 acres. Much of the water at present runs to waste. It is stated that one man can irrigate 12 acres a day with the output of the wells.

*Brady ranch.*—Near the Collins ranch is that of T. F. Brady, on which is a 6-inch open-bottom well 1,500 feet deep. This has a static pressure above the ground of about 15 feet, and the flow of the well is sufficient to fill two 6-inch horizontal pipes. This would probably mean a flow of 800 gallons per minute. Mr. Brady irrigates 50 acres in garden truck and runs the surplus water into a tank, and estimates that he could irrigate 40 acres more. He also supplies three tenants with water in addition to irrigating his own place. According to his figures, it would cost \$2 a foot for 1,000 feet of 6-inch well, provided the owner furnished casing. The furrows used for irrigation were 75 yards long, and the length of time consumed in running the water through them was fifteen minutes.

*Wautrs ranch.*—Near the Brady place is a ranch owned by F. Wautrs which has a 6-inch well 1,474 feet deep. This well delivers a flow of 45 gallons per minute, and water will rise 16 feet above the level of the ground without flow. The artesian stratum from which the well derives its water is evidently of a close porous formation, which throttles very much the water which can be obtained from the well.

Near the well is an earth tank, which, however, is not often used, the practice being to pump direct from the well onto the ground. The reservoir is 100 by 75 feet, with banks 3 feet wide on top. The total depth of the reservoir is 6 feet, owing to the excavation for the banks, but of this only 4.5 feet are available for storage. The reservoir cost \$65. It takes twenty-four hours to fill the tank with the pump running and four days and nights to fill it from the well alone. The area irrigated is 50 acres. Two to 4 acres can be irrigated with the pump in fourteen hours. The water-bearing stratum of the well is rock, at a depth of 1,235 feet. The pumping plant consists of a direct-acting steam pump set in a pit and a 12-horse-power vertical boiler. The cost of the well was \$4,000 complete. The cost of the boiler, pump, and house was \$900. The fuel consumed is 0.5 ton Lytle coal in fourteen hours and costs \$1.35 per ton. The yield from 2.25 acres was 557 bushels of potatoes. The land is planted to truck and is irrigated by the furrow system. The rows are 120 yards long, and it takes one to five hours to run the water through them. The soil is of a black, waxy nature and is carefully cultivated. The well when pumped has a flow of 142 gallons per minute.

*Reichert ranch.*—In the same vicinity is the farm of Mr. Reichert, on which is a 6-inch well 1,200 feet deep. Water will rise in this well without flow 20 feet above the ground. At present 25 acres are irrigated from the well, and the crops raised are cane, corn, and truck. An earth tank 70 by 100 feet, with 3 feet available depth of water, is utilized, mainly to avoid the necessity of running at night. It is stated that 5 acres more could be irrigated with the same water. Truck is irrigated every ten days. Cane and corn each receive two irrigations per year in dry weather. The furrow system is used, the furrows being 100 yards long and 3 feet apart. It takes the water one to four hours to run through the furrows. Level land takes about an hour and hilly land about four hours. The well discharges in the neighborhood of 300 gallons per minute. The usual rate of irrigation is 1 acre with ten hours' flow.

*J. Epp, jr., ranch.*—In the same vicinity is the ranch of J. Epp, jr. The water is furnished by a 4.25-inch artesian well 884 feet deep. The well stands without flow 20 feet above the ground and delivers 200 gallons per minute. The area irrigated from this well is 21 acres, 10 of which are farmed by the owner of the well and planted in corn and Johnson grass. The remaining 11 acres are planted in truck and cultivated by tenants, who are allowed the water six days out of every nine. Irrigation goes on day and night. No reservoir is used. All irrigation is performed by the furrow system. The total flow of the well will irrigate 0.5 acre of corn in twenty-four

hours. The cost of the well was \$3,500. Part of the water is delivered through 1,700 feet of 3-inch pipe to a point 5 feet above the level of the well. This of course cuts down greatly the supply of water, due to extra elevation and friction loss in the pipe. For night runs the water is turned into four or five furrows 300 feet long 3.5 feet apart, and runs in them all night.

*Barnes ranch.*—Adjoining the Collins ranch is the property of Mr. Barnes, with an artesian well with a capacity of about 1,100 gallons per minute. This well is provided with a throttle valve, as are also many of the other wells in the vicinity of San Antonio. This is a wise provision, as it prevents waste of water.

*Meerscheidt & Stieren Irrigation Company.*—The ranch of this company is about 4 miles west of San Antonio. It consists of 572 acres ready for cultivation, but at present only 470 acres is cultivated. Of this land, 200 acres is planted to truck, 170 to cotton, and 100 to corn. The land is all leased to tenants and water for irrigation is furnished them from a 10-inch well. The elevation of the land is considerably above the level of San Antonio, and water stands without flow in the well about 2 feet below the level of the ground. The pump station which has been installed has the following equipment: One 80-horsepower horizontal tubular boiler; one 80-horsepower automatic simple engine, belted to a centrifugal pump. The pump is set in a brick pit 12 feet in diameter and 20 feet deep.

The well was started with 12-inch casing, which went down 45 feet; then 10-inch casing for 850 feet, and an 8.25-inch hole 110 feet deep, the well being 1,005 feet deep. The pump is a No. 8 special, with 12-inch suction and 10-inch discharge. When operated at the speed at which the pump is normally run, the suction on the pump is 25 feet and the lift and friction loss in discharge pipe 25 feet, making the total head against which the pump must operate 50 feet. The fuel consumed is 2.75 tons Lytle coal in ten hours' run, costing \$1.75 per ton delivered. One man operates the entire station. The pump runs ten hours per day for about two hundred days a year.

The ditches for conveying the water go in four directions from the station and are 3 feet wide on the bottom, 5 to 6 feet wide on top, and 2 feet deep.

Some of the strata passed through by the well is as follows:

First rock, at a depth of 625 feet.

At 670 feet sulphur water was encountered.

At 765 feet, brown rock and a small quantity of water.

At 800 feet, white rock.

At 865 feet, mudhole.

At 930 feet was a second water rock, from which the supply for the well is obtained.

The well was sunk to a depth of 1,005 feet in the hope of obtaining flow, but, as said above, the elevation of the ground is too great. The well is open bottom and is apparently limited in flow only by friction in the pipe itself. The cost of the well was \$4,500, and the cost of the pumping plant was \$3,000. The output of the well when pump is running full capacity is 2,500 gallons per minute. The cost of running the plant, as figured by the owners, is \$10 a day, segregated as follows:

Attendance .....	\$1.00
Coal .....	5.00
Interest, depreciation, and operating expenses.....	4.00
Cost of pumping per acre-foot, about.....	2.20

The steam plant irrigates 350 acres of the tract. The remaining 120 acres are irrigated from a separate plant near by, supplied from a 6-inch well, to which is attached a No. 6 centrifugal pump delivering a flow of 433 gallons per minute. The pump is placed in a pit 10 feet deep and is driven by a 12-horsepower gasoline engine, which uses, in twenty hours' run, 29 gallons of gasoline, costing 13 cents per gallon. The average daily run of the plant is six hours. A run of three to four hours is required for an acre. The land is irrigated by the furrow system, the furrows being 200 feet long. The entire flow of the pump will take one-half to one hour to run through the furrows, the flow being divided between 40 furrows. The plant is said to have sufficient capacity to irrigate 200 acres. The cost of the well was \$2,700, and of the station \$1,300. The well is 980 feet deep, being 650 feet to the first rock, which is 260 feet thick. Below this is the formation found throughout this region, known as "mudhole," 50 feet deep. Twenty feet below this is the second rock, containing the water supply. Water stands without flow close to the surface of the ground.

Land and irrigation water from the steam plant are furnished tenants at an annual rate of \$17 an acre. The plant has been in operation but a comparatively short time. The following is the form of contract between the company and the tenants which has recently been prepared:

**STATE OF TEXAS, County of Berar:**

This agreement, this day made and entered into by and between Meerscheldt & Stieren Irrigation Co., as party of the first part, and \_\_\_\_\_, as party of the second part, witnesseth:

1. The party of the first part hereby leases for the term of \_\_\_\_\_ years, beginning on the \_\_\_\_\_ day of \_\_\_\_\_, 190\_\_\_\_, and ending on the \_\_\_\_\_ day of \_\_\_\_\_, 190\_\_\_\_, the following described tract or parcel of land out of their irrigation farm near and within the city of San Antonio, Texas, on the Castroville road and Cupples lane, and containing \_\_\_\_\_ acres of land: \_\_\_\_\_.

2. The party of the second part agrees to pay the sum of \$\_\_\_\_\_ per acre for said land, to be paid as follows: \$\_\_\_\_\_ in cash upon signing or taking posses-

sion of said land and the balance in — equal payments. \$—— on the first day of ——, 190—, \$—— on the first day of ——, 190—, \$—— on the first day of ——, 190—.

3. The party of the first part further leases to the party of the second part — acres of land —— on shares—that is to say, each party to receive one-half of the crop raised and gathered thereon, and the party of the second part agrees to gather and deliver the equal one-half part belonging to parties of the first part to them on said farm, or if so desired to market and sell same in the city of San Antonio and turn over the money realized from such sale to the parties of the first part, in their office in the city of San Antonio, Texas, ——.

4. The party of the first part agrees to furnish out of their well, at their own expense, to the second party, once every week, one-third of the water pumped out of their well in ten hours for each fifteen acres rented for money rent, and for land leased on shares only surplus water will be furnished, to be left to discretion of first parties after all land rented for money has been supplied; however, that the parties of the first part shall not be responsible to the second party for any damages for failure to supply water by reason of a breakdown in the machinery, or if for any reason the well fails to furnish sufficient water, as long as the first parties make reasonable efforts to repair any breakdown and pump the water contained in the well. And it is understood that in case their well should diminish, or if for any reason it should become impossible for the party of the first part to furnish sufficient water to the party of the second part, as hereinbefore agreed, to make a crop, the damages therefor shall never exceed the amount of rent the party of the first part agrees to pay ——.

5. The party of the first part agrees to furnish to the party of the second part a house and stable with said land, and being house known as No. ——.

6. The party of the second part agrees to cultivate his crop in a good farmer and gardener like manner and to keep the land free of weeds and Johnson grass and to furnish all labor, tools, teams, and seed necessary to such cultivation, and he is to make the ditches on the land so leased and to keep them in repair and clean of weeds, and he further agrees to pay his rent promptly, as hereinbefore set out, and a failure to comply fully with this article shall forfeit this lease ——.

7. It is further agreed and understood by the parties to this contract that the parties of the first part have a lien on any and all crops raised on said leased land for rents due and to become due, and for advances made, if any, to such tenant ——.

Witness our hands this —— day of ——, 190—.

\_\_\_\_\_  
 \_\_\_\_\_

As will be seen, the contracts provide for payment in part of the crop, for a cash consideration per acre, or for a combination of the two.

#### SAN ANTONIO SEWAGE.

The city of San Antonio has a population of 60,000. The water supply per capita is 167 gallons per day. In 1904 there were 3,462 houses, or about one-third of the total number in the town, connected with the sewerage system. According to the report of the city engineer, the average rate of flow of sewage water is 11 cubic feet per sec-

ond. On the basis of the above figures, and assuming that six people occupy a house, the water consumed per house would be 1,000 gallons per day. This would account for only four-sevenths of the flow of the sewer. The remaining three-sevenths of its supply comes from seepage into the brick sewer.

The sewage of San Antonio had previously been disposed of by utilizing the water for irrigation on the old sewer farm, a short distance outside the city limits. As a sanitary precaution, however, it was decided to convey the sewage several miles farther, to the vicinity of Mitchells Lake. The San Antonio Irrigation Company, of which H. McC. Potter is manager, has obtained from the city the right to utilize this sewage water for ninety-nine years for the disposal of the same. The Government experiment farm, which is close by the old sewage farm, had previously used the sewage water for irrigation, but is at present cut off from this supply.

The pipe line for conveying the sewage ends a short distance beyond the old sewage farm, from which point the water is conveyed by a

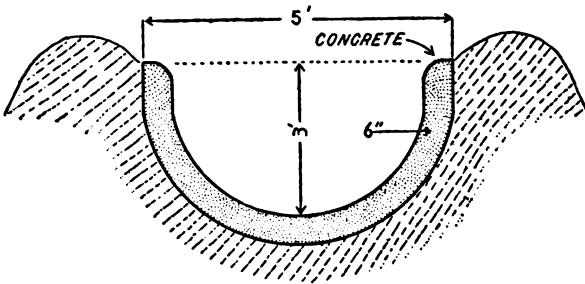

FIG. 58.—Section of San Antonio sewage ditch.

ditch to Mitchells Lake, a distance of 7 miles. The ditch is 4.5 feet wide on the bottom, 3 feet deep, with side slopes of 1 to 1 and a grade of 4.5 feet per mile. The banks have a 3-foot crown. The ditch is designed to carry 20,000 gallons per day.

In addition to the ditch, 1,500 feet of flume are used, of the following sizes: 6 by 2, 5 by 2.5, and 4 by 2.5 feet. The sections of flume are constructed of cypress, with 2-inch bottom and sides and 4 by 4 inch posts bolted to stringers set 8 feet apart. The flumes are set on a grade of 10 feet per mile.

A wooden retaining wall has been constructed where the ditch is in a cut 700 feet long in loose ground. The joists are on the inside of this wall, which is an objectionable feature, as they form stopping places for sediment. It would have been better had they been placed on the outside of the wall and the timbers bolted through.

Two thousand two hundred feet of open concrete invert were also used, of a semielliptical section 3 feet in depth and 4 feet across at the top (fig. 58). The thickness of the concrete lining is 6 inches.

The lining was put in when the embankment was green and has cracked in places. The concrete cost 90 cents per square yard.

According to the city engineer's estimate, the following acreage is available for irrigation from sewage water without the use of pumps:

	Acres.
From the point where the pipe line crosses the San Antonio River to the sewer farm.....	400
Sewer farm and land lying east of it.....	350
Sewer farm to Mitchells Lake.....	300
In addition to this, the Mitchells Lake property:	
Filter beds.....	550
Cultivated filter beds.....	400
Land which can be irrigated from the lake and canal....	375
Land irrigated from the lake only.....	125
Total.....	2,500

Mitchells Lake, a shallow basin through which the drainage water from a large section of country runs, formerly went dry in the summer time. At present the outlet of the lake has been closed by a dirt dam 250 yards long with a slope of 3 to 1 on the inside and 2 to 1 on the outside. The spillway, which includes the entire length of the dam, is 1,000 feet long and is well covered with sod. It is of such ample dimensions that no cutting has resulted from the water which passes over it. The lake when full covers an area of 864 acres, with a depth of water of 2 to 10 feet. The storm waters, which drain into the lake from a section reaching as far as San Antonio, all pass through a natural basin, the utilization of which the company is at present contemplating by the erection of a dam 2,400 feet long, with a maximum height above the ground level of 38 feet. The estimated capacity of the reservoir is 8,000,000,000 gallons. Leona Creek will be used as a wasteway for the reservoir. If this reservoir were constructed, Mitchells Lake could be drained and the land used for agricultural purposes.

The company figures that 2,000 acres are available for irrigation by gravity under the existing canal, and that by damming the storage basin 2,500 acres additional will be made available, of which 1,000 acres could be irrigated from the sewage supply by gravity alone if desired. According to the figures of the city engineer, the present sewage water supply is sufficient for the irrigation of 2,000 acres. This would give a duty of about 180 acres per 1 cubic foot per second.

The sewage water which is at present not used for irrigation is spread over what are known as filter beds—large sandy and gravelly tracts—and eventually finds its way by percolation through the soil into Mitchells Lake. The water is distributed over the filter beds by means of small laterals 4 feet wide on top and 8 inches deep, con-

structed with V scrapers and run on a grade of 1 foot to the mile. Part of the filter beds can be used for farming. There are about 2 miles of ditches in the filter beds, through which the water is turned into different sections as occasion may demand. By the time the sewage reaches the filter beds there are no solids left in the water.

At present there are 450 acres under irrigation, planted as follows:

140 acres in Indian corn, irrigated three times a year.

75 acres in Kafir corn, irrigated three times a year.

80 acres in sorghum, irrigated three times a year

25 acres in sweet potatoes.

100 acres in cassava, peanuts, cowpeas, etc.

30 acres in Irish potatoes and alfalfa.

Irrigation commenced March 1. Sorghum matured in fifty days and sweet potatoes in ninety days. Furrow irrigation was practiced for all crops except alfalfa, which was flooded by the bed system, the beds being about 25 feet wide. The laterals are about 300 feet apart.

#### SAN ANTONIO RIVER.

San Antonio River, in addition to the supply of water from the springs at its source, receives considerable additions farther down from seepage and from the creeks which run into it. Several pumping plants have recently been installed considerable distances below the city, which utilize this water for irrigation.

*Ballard plant.*—At Floresville, on San Antonio River, Mr. Ballard has installed on his farm of 150 acres an irrigation pumping plant consisting of a 65-horsepower boiler furnishing steam at 30 pounds pressure to a duplex pump delivering a flow of 500 gallons per minute. Water is raised 47 feet and 1 cord of mesquite is consumed in twelve hours' run. One hour's run of the pump will irrigate an acre. Mr. Ballard expects to put in 8 acres of onions this year (1905), to be irrigated by the bed system, the beds being 13 by 100 feet. Forty to 50 tons of manure per acre are used for fertilizer.

*Spencer plant.*—At Falls City, on the San Antonio River, is the irrigation plant of C. W. Spencer. This plant has just been installed and is intended to irrigate 15 acres. A No. 3 centrifugal pump driven by a 12-horsepower gasoline engine will be used to raise the water 50 feet, forcing it through 450 feet of 4-inch pipe.

*McKay plant.*—Six miles from Falls City, on San Antonio River, Dr. Donald McKay has installed an irrigation pumping plant consisting of a 15-horsepower portable engine belted to a No. 5 centrifugal pump. The lift is 37 feet. The fuel consumption is 1 cord of mesquite for twelve hours' run, during which time 4 acres are irrigated. The water is pumped through 95 feet of  $5\frac{3}{8}$ -inch pipe. Wood costs 75 cents a cord and is cut on the ranch. The present plant irrigates



26 acres. According to the owner's figures 50 acres could be irrigated. The following crops were grown on the land:

*Crop returns.*

Crop.	Acres.	Irriga- tions per season.	Yield per acre.
Onions .....	5	10	22,000 pounds.
Potatoes .....	5	2	100 bushels.
Melons .....	5	4	75 bushels.
Cotton .....	6	1	Failure.
Corn .....	5	1	40 bushels.

Corn not irrigated yielded 20 bushels per acre. The onions were placed in rows 12 inches apart, the spacing being 5 inches. Transplanting the onions required thirty days' labor per acre and harvesting five days.

The soil is alluvial and cements easily. No fertilizer was used. The bed system of irrigation is employed for onions, the beds being 12 by 100 feet and the slope 1 inch per 100 feet. The entire flow of the pump is utilized on 2 to 4 beds at a time, and when irrigating 2 beds about ten minutes flow is required. Crops other than onions are irrigated by the furrow system, the furrows being 200 to 600 feet long, with a slope varying from 2 inches to 1 foot per 100 feet.

*Weir plant.*—Near Karnes City Peter Weir has installed an irrigation plant pumping water from San Antonio River with the following equipment: 100-horsepower horizontal tubular boiler; 100-horsepower throttling engine, speed 140 revolutions per minute, which drives through belting a No. 8 centrifugal pump provided with 10-inch suction and discharge, throwing a stream of 2,500 gallons per minute. The pump makes 400 revolutions per minute. Water is raised 47 feet vertically through 75 feet of 10-inch pipe. The fuel consumption of the plant is 1.5 cords of wood in twelve hours.

Water is pumped into a canal 25 feet wide with a maximum depth of 6 feet and an average depth of 3.5 feet. It is 0.75 mile long, and is utilized in part to store water.

At present 110 acres are irrigated by the plant, 65 acres being planted in corn, of which the yield is claimed to be 70 bushels per acre.

The land is rented out to tenants under contracts, of which the following is a copy:

STATE OF TEXAS, *County of Karnes:*

This contract, made by and between Peter Weir and ————, both of Karnes County, Texas, witnesseth: That said Peter Weir has this day leased and rented to the said ———— for the term of ———— months, beginning on the ———— day of ————, A. D. 190—, and ending on the ———— day of ————, A. D. 190—, that certain ———— acres of land this day marked and staked off by the parties hereto, it being a part of the farm of the said Peter Weir, situated in Karnes County, Texas, about four miles north of the town of Karnes City, on the San Antonio River, and being a part of the A. Lombrano grant.

Said Peter Weir further agrees to furnish from the San Antonio River with his pumping machinery, in the main ditch or canal near said land, sufficient water to irrigate said land and to water the crops that may be growing thereon at all necessary times for and during the term of this lease.

It is expressly stipulated and agreed, however, that the said Peter Weir shall only be required to exercise reasonable diligence to supply the water for irrigation purposes above mentioned, and he shall not be liable for damages on account of a failure to supply such water occasioned by a breakage in machinery or accident thereto, high water, failure of the water in the river, breakage in canal, or from any other cause that can not be provided against with reasonable prudence.

For the rent of said land and the use of said water for and during the term of this lease the said \_\_\_\_\_ agrees to pay to the said Peter Weir, at Karnes City, Texas, the sum of \$\_\_\_\_\_, as follows: \$\_\_\_\_\_ cash, the receipt of which is now here acknowledged by the said Weir, and \$\_\_\_\_\_ on the \_\_\_\_\_ day of \_\_\_\_\_, A. D. 190—, and \$\_\_\_\_\_ on the \_\_\_\_\_ day of \_\_\_\_\_, A. D. 190—, and a first lien is now here acknowledged on all the crops grown and to be grown on said land for and during the term of this lease to secure the payment of all said sums of money.

It is further understood and agreed that the said Peter Weir shall, either in person or by an agent, at all times, during usual working hours, be at or near said pumping plant, and the said \_\_\_\_\_ shall not take any water from said main ditch or canal, except as hereinafter provided, until the consent of the said Peter Weir or his said agent shall have first been obtained, and then only such quantity of water shall be taken as shall be prescribed by the said Weir or his agent: *Provided*, That the said \_\_\_\_\_ shall always be entitled to water on \_\_\_\_\_ of each week, and at his request shall also be entitled to water at any time during transplanting.

The said \_\_\_\_\_ hereby agrees to work and cultivate said premises in a good and farm-like manner during the term of this lease and to peaceably surrender the possession thereof to the said Weir at the termination thereof in as good condition as it now is, natural wear and tear, the act of God or a public enemy alone excepted.

Witness our hands this \_\_\_\_\_ day of \_\_\_\_\_, A. D. 190—

\_\_\_\_\_  
\_\_\_\_\_

Land adjoining the plant has increased in value \$17 to \$25 per acre since its installation.

With furrow irrigation the pump flow is used on 30 rows 250 yards long, taking about an hour to flow through the same.

The corn crop was planted early in March and harvested the first part of September. It was irrigated twice. Without rain it would require three irrigations.

Wood for fuel costs \$1.25 per cord, being cut from the land of the owner of the plant.

*Delutz-Campbell plant.*—Near Karnes City is another irrigation plant pumping from San Antonio River, owned by Delutz and Campbell. In 1903-4 8 acres were irrigated by this plant: Six in onions, 1 in melons, 0.5 in potatoes, and 0.5 in truck. This year (1905) 20 acres will be irrigated—15 in onions and 5 in cabbage. Water is

pumped from the river by a No. 3 centrifugal pump driven by a 10-horsepower gasoline engine consuming 1.25 gallons of gasoline per hour. The lift is 44 feet and the flow 295 gallons per minute as measured. The present plant will irrigate about 3 acres of onions in ten hours. Last year's onion yield was 14,000 pounds per acre, for which the price received was 2 cents per pound f. o. b. No fertilizer was used. Onions were planted October 15 and harvested April 15-20. Transplanting took 10 men three weeks and harvesting 5 men two weeks. The onions were planted 4 inches apart in rows 14 inches apart. The bed system of irrigation was used, beds being 12 by 100 feet. The entire flow of the pump required five to eight minutes to irrigate a bed. The first part of the season the onions were irrigated every two weeks and after that every seven or eight days. About 12 irrigations were required during the season. The onions weighed 1.25 to 1.5 pounds each. It is the intention of the owners to install later a No. 6 pump driven by a 40-horsepower engine, to irrigate 70 acres.

#### BEEVILLE.

In the country near Beeville there are several successful small irrigation plants which illustrate how trucking may be carried on to advantage by a man of small means. The water supply is obtained entirely from pumped wells which furnish a comparatively limited flow. In consequence much greater economy is practiced here in the use of water than in most other parts of Texas which the writer visited. All kinds of soil are found within a short distance, varying from a sandy to a waxy consistency.

The State experiment station, of which Mr. Robertson is at present in charge, is situated about 6 miles from Beeville. Experiments have been conducted there to determine the commercial value of irrigation which show clearly its great importance. Reports are carefully kept of the cost of various operations and the labor necessary for growing a crop and the results, from irrigated and nonirrigated land show a striking contrast.

A well 1,333 feet deep was bored in an attempt to obtain artesian water near Beeville. At 40 feet the first water stratum, which was of small capacity, was encountered, water standing at that level. At 65 feet the water rose to within 30 feet of the ground surface. At 237 feet in fine sand a good supply of water was encountered which rose to within 37 feet of the surface. At 400 feet a better supply was encountered and at 600 feet the water rose to within 9 feet of the surface. No artesian flow, however, was struck. The formations encountered in well boring near Beeville are in general as follows.

From 35 feet down to 65 to 80 feet the ground is porous clay rock with a small water supply.

From there to 100 feet is a stratum of sand.

At 120 feet is a 5-foot vein of quicksand.

At 224 feet is another water-bearing stratum of sand.

These conditions hold to about 4 miles east of the town. About 6 miles west of the town the formation is rock to a depth of 125 to 150 feet. At 120 feet is a water-bearing stratum of rock. At 150 feet is a water-bearing sand stratum. Nearer Beeville between depths of 40 and 100 feet the ground is honeycombed sand rock yielding a limited water supply and which is underlaid with about 60 feet of clay. Twelve miles west of Beeville is a gravel stratum between 100 and 150 foot levels. Water stands 130 feet from the ground.

In the northern part of Bee County the wells are small. At the 60-foot level a small amount of seepage was encountered in a well at Pettus, and at the 220-foot level the well was dry. West of Bee County, at 150-foot levels, is a water-bearing stratum of sand and gravel which furnishes a fair flow. Water stands 100 feet from the surface of the ground. In the southern part of the county the water gravel is 40 feet below the surface and furnishes a good supply. Water stands without flow 30 feet from the surface of the ground. In the eastern part of the county the water-bearing sand is 100 feet below the surface and furnishes a good supply. The lift is 50 feet.

At Pettus, 19 miles north of Beeville, is a dug well near the bank of Medio Creek, which is said to furnish a good supply of water. At Skidmore is a well 180 feet deep, dug 8 feet square for the first 100 feet and drilled for the remaining 80 feet, supplied with 8 and 12 inch casing. Water stands 120 feet from the surface. The water strata were encountered at 90, 120, and 180 feet, the stratum at 180 feet being gravel. A steam pump is set 15 feet above the water level. The length of suction pipe is 28 feet. The delivery of the pump is 100 gallons per minute.

At Sinton, near Chiltipin Creek, is a pumped well delivering 95 gallons per minute. A well 1,600 feet deep was put down in this vicinity in the hope of finding artesian water. Strata of water-bearing gravel were encountered between 75 and 400 feet, but no artesian flow was obtained.

H. M. Perry irrigates 25 acres southwest of Skidmore. A 6-horse-power engine drives a pump delivering 75 gallons per minute against a lift of 140 feet. A reservoir of 500,000 gallons capacity is used.

Near Driscoll are three small farms of 15 to 20 acres each irrigated by pumping.

*Beeville experiment station.*—According to the figures of J. K. Robertson, irrigation for trucking in the vicinity of Beeville requires an average of 1 inch depth of water applied every 10 days when the weather is dry. The irrigations required per year per crop are two to ten. The pumping plant at the experiment station consists of a deep-well pump operated by a gasoline engine delivering 65 gallons per minute against a lift of 90 feet, utilizing 4.5 gallons of gasoline in ten hours at a cost of 14.5 cents per gallon. An earth reservoir 62 by 44 top inside measurements, 8 feet deep, side slope 1 to 1.5, capacity 90,000 gallons, is used in connection with the pumping plant. The well from which the water supply is obtained is 100 feet deep, the water being in a porous adobe formation. In the summer of 1904, water stood 65 feet below the surface of the ground. Formerly the level was 15 to 20 feet higher. Water is pumped by a 6 by 22 inch deep-well pump run at 32 strokes per minute. Pumping at this rate the well pit is emptied in five hours. The probable flow into the pit when empty is estimated at 45 gallons per minute.

The reservoir is lined with a mixture of 73 per cent sand, 2 per cent lime, and 25 per cent coal tar. Air-slaked lime and sand were mixed dry and poured into boiling coal tar. Fifty-three pounds of mixture per square yard were used. The surface was coated with a flashed tar applied as a paint, made by boiling tar twenty minutes and flashing it while boiling until the grease was burned out. This lining has worked quite satisfactorily.

Mr. Robertson figures that the cost of gasoline for raising water near Beeville was 4 cents per 1,000 gallons.

The land on the experiment station used for truck growing was fertilized at a cost of \$7 per acre with the following commercial fertilizer: Five parts of nitrate of soda, 6 of acid phosphate, 9 of muriate of potash. The two latter were applied from seven to ten days before setting out onions, and the former in two applications, one when the bulb was half grown and the other when the onions were half grown. Five hundred pounds per acre was applied and the same required from one-half to five hours' labor for its application. Three pounds of onion seed, at \$2 per pound, were used per acre. The following are figures made by Mr. Robertson on the cost of farming and the yield of land with and without irrigation. The time was carefully kept of all operations required for one-twentieth of an acre.

*Cost of farming 1 acre of nonirrigated land.*

Plowing and harrowing.....	\$2. 00
Laying off furrows, labor in irrigation before planting, etc..	2. 00
Restirring with 5-tooth cultivator.....	2. 00
Transplanting onions.....	9. 00
Water for irrigation before planting (40,000 gallons).....	1. 60
Eight cultivations.....	3. 60
Hand weeding.....	5. 00
Pulling onions, 33.3 hours, at 7½ cents.....	2. 50
Trimming, sacking, and weighing, 100 hours, at 7.5 cents....	7. 50
<b>Total</b> .....	<b>35. 20</b>

NOTE.—The land received one irrigation only before planting.

The following was the cost for irrigated land :

Plowing and harrowing.....	\$2. 00
Laying off furrows, and labor of irrigation before planting..	2. 00
Restirring.....	2. 00
Transplanting .....	9. 00
Water for irrigation before planting.....	1. 60
Eight cultivations.....	3. 60
Laying off rows for irrigating after planting.....	1. 50
Four irrigations—water.....	6. 70
Four irrigations—labor.....	4. 80
Pulling, trimming, sacking, and weighing, 190 hours, at 7.5 cents.....	14. 25
<b>Total</b> .....	<b>47. 45</b>

The onions were red Bermuda, planted 4½ inches apart in the rows, which were 15 inches on centers. The nonirrigated land yielded 19,075 pounds per acre, and the irrigated land 38,056 pounds per acre. Onions planted with the above spacing gave the following yield in pounds from a 50-foot row :

	Pounds.
Red Bermuda.....	63. 50
White Bermuda .....	49. 25
Creole .....	35. 25

Irrigated onions required no hand weeding; unirrigated onions required 10 days' labor in weeding per acre.

The following are the comparative results of the irrigated and unirrigated cabbage land. One-eighth acre was used in obtaining these figures, but the results are reduced to cost per acre :

*Unirrigated, except for planting.*

Man and team laying off rows, 4 hours.....	\$0. 80
One man. 4 hours, irrigating.....	. 40
Water for irrigation before planting.....	. 80
Labor, transplanting, 30 hours.....	2. 72
One man raking in furrows.....	. 80
Man and mule, 9 cultivations.....	2. 06
Hoeing, 6 hours.....	. 60
<b>Total</b> .....	<b>9. 08</b>

*Cost of farming irrigated cabbage per acre.*

Man and team, laying off rows, 4 hours.....	\$0. 80
Six irrigations (167,000 gallons).....	6. 80
Labor, 6 irrigations, making ditch, etc., 22 hours.....	2. 20
Man and mule, 9 cultivations.....	2. 96
Labor, transplanting, 30 hours.....	2. 72
Labor, raking in furrows.....	. 80
Labor, hoeing, 6 hours.....	. 60
Total .....	16. 88

There were 8,320 plants transplanted, 152 being killed by black rot, 2,720 plants failed to head, and 5,448 plants yielded a total of 6,144 pounds on the unirrigated land.

Irrigated land which had the same number of plants transplanted yielded 17,632 pounds, 248 plants being killed by black rot, 80 failed to head, and 7,992 matured.

The following prices were received for cabbage in 1904: In February, 1.90, 1.76, 1.75, 2.02 cents per pound; in March, 1.96, 2.17 cents per pound, and in April, 2.26 cents per pound. The average for February was 1.86 cents, for March, 2.07 cents, and the average for February, March, and April, 2.05 cents. Figuring on 2 cents per pound, the irrigated land yielded a return of \$352, whereas the yield of unirrigated cabbage was only \$123.

These figures demonstrate beyond a doubt the absolute commercial necessity of irrigation, particularly in view of the comparatively small cost of the same and vastly increased returns, the difference in cost being only \$7.80 per acre, with an increased yield equivalent to a profit of \$229. These figures represent what can be obtained by skillful farmers and are considerably above the average.

*Rankin farm.*—In the country around Beeville there are several thriving truck farms, the most successful of which belongs to Carl Rankin. The water supply for irrigation comes from three wells, two of which are pumped by 12-foot windmills and the third by a gasoline engine. The present supply of water is just sufficient for the irrigation of 20 acres, 15 of which belong to Mr. Rankin and 5 to a neighbor. By far the larger part of the water supply is derived from the engine-driven pump, the well for which is of 5 $\frac{1}{8}$ -inch casing and 175 feet deep, the water standing about 40 feet from the ground level. From experience in wells near by, water will be lowered at a rate of probably 6 inches per 1 gallon per minute rate of flow. A deep-well pump, 3.75 by 24, is driven at 32 strokes per minute by a gasoline engine of 2 $\frac{1}{2}$  horsepower. The capacity of this pump is 37 gallons per minute. The end of the pump cylinder is 40 feet below the standing-water level. The pump discharge into an earth reservoir, 80 by 52 feet top inside measurement, and about 6 feet deep, the banks having a slope of 1 vertical and 2 horizontal.

The pump, engine, well, and house complete cost \$1,000. The cost of boring wells in this vicinity is 50 cents per foot.

The gasoline engine runs day and night without attention. The owner estimates that the engine runs one-third of the year. Gasoline at 14 cents per gallon costs 80 cents for twenty-four hours' run. Labor for irrigating 1 acre costs 60 cents to \$1. Irrigation is carried on during the day only, the pump discharging into the reservoir at night. Twenty-four hours' run of the pump will furnish sufficient water for the irrigation of 2 acres. Freshly plowed land will take at the start twice this quantity of water. Truck land is irrigated every ten days in dry weather.

The soil on this ranch varies from black waxy to light sandy, and is 1 to 2 feet thick, underlain with a red clay subsoil. The land is all fertilized with barnyard manure.

This farm is a good example of the benefits of diversified farming. All kinds of vegetables and truck are grown on the land, and the owner says he is able to sell some kind of produce from the farm every day in the year. The land requires six to eight irrigations per crop per year for truck raising. The land originally cost \$25 per acre a short time ago and it is now greatly increased in value. Five acres of radishes marketed between January and March brought \$200 per acre. One acre of beets yielded 145 barrels—264 bunches to the barrel.

*Benton farm.*—Adjoining the Rankin farm is the farm of Mr. Benton. A well for irrigation purposes has recently been sunk to the same depth as the Rankin well, the water standing 42.5 feet below the ground level. A test was made on this well to determine the relation between the delivery of the well and the distance the ground water was lowered. This gave the following results:

*Effect of pumping on level of ground water.*

Gallons per minute.	Depth water was lowered.	Gallons per minute.	Depth water was lowered.
	<i>Feet.</i>		<i>Feet.</i>
00	00	12.9	7.5
20.7	11.2	8.8	5.6
20.7	11.3	7.2	4.5
17.1	10	20.3	11.2

This indicates that the flow of this well, which is open bottom, is directly proportional to the distance which the ground water level is lowered.

*Messenger farm.*—W. D. Messenger irrigates 10 acres of land from a pumped well 6.25 inches in diameter, 90 feet deep, and cased 40 feet. The pump delivers water into an earthen tank 40 by 55 feet inside top measurements, side slopes 1 vertical to 1.5 horizontal. The tank is about 5 feet deep and cost \$250. The cost of the well,



ditches, 3-horsepower gasoline engine, and 4-inch deep-well pump was \$750. The cost of the land was \$40 per acre. The land was fertilized with manure costing 10 cents per 2-horse load.

*Stovall farm.*—A. M. Stovall irrigates a small tract with water from a 6-inch pumped well. The water stands 36 feet below the ground level and is raised 6 feet above the surface to the top of an earth reservoir. A 1.5-horsepower gasoline engine drives a 3.75 by 20 inch deep-well pump 30 strokes per minute, delivering 1 gallon per minute per stroke. The engine uses 4 gallons of gasoline in twenty-four hours. The suction pipe of the deep-well pump is 25 feet below the level of the standing water. The reservoir is 45 feet inside base diameter, with side slopes 1 to 1, and is 5.5 feet deep. The total cost of plant was \$425.

*Eidson plant.*—Mr. Eidson has an irrigation plant which obtains its water supply from a pumped well 60 feet deep; the distance from ground to standing water is 35 feet. A 2.5 horsepower gasoline engine drives a 3.75 by 24 inch deep-well pump 30 strokes per minute and delivers water 6.5 feet above the ground level into an earthen tank 88 feet inside top diameter with side slopes of 1 vertical to 2 horizontal. The cost of the reservoir was \$200; total cost of plant, including reservoir, \$800. Seven acres in corn, beets, and truck are irrigated. The pump delivers 30 gallons per minute. The cost of gasoline was 17 cents per gallon and of operation for twenty-four hours 75 cents. In boring the well the first water-bearing stratum was encountered at 30 feet, but was very weak. At 60 feet the water stratum consisted of 2 feet of gravel. The reservoir capacity is 200,000 gallons.

*Muckleroy farm.*—R. C. Muckleroy has a farm 4 miles south of Beeville, which derives its water supply for irrigation from a well 59 feet deep. The suction pipe of the deep-well pump is within 2 feet of the bottom of the well. The water stands 24 feet below the ground level and is elevated 6.5 feet farther to the top and discharges into an earthen reservoir 65 feet inside top diameter and 6 feet deep, with side slopes of 1 vertical to 1.5 horizontal. The well is of 5 $\frac{3}{8}$ -inch casing. A 2.5-horsepower gasoline engine drives a 3.75 by 24 inch deep-well pump 30 strokes per minute. The cost of the reservoir was \$200; cost of engine, \$245; cost of well boring, 55 cents per foot. The well is cased 53 feet. Below the standing water level is a 30-foot sand stratum and 5 feet of stone, the soil being 10 inches thick, underlain with clay subsoil.

Cabbage set out in September was shipped in December and February, and was followed by a crop of black-eyed peas planted May 1 and plowed under August 1. On the same land a crop of cauliflower and cabbage was set out in September and shipped in December and January. English peas planted September 1 were shipped

October 15-30, and radishes planted November 1 were shipped December 15-30.

*Grissett place.*—C. L. Grissett has a farm irrigated from a well 160 feet deep. Water stands about 44 feet below the ground level. A 4-horsepower gasoline engine drives a  $3\frac{3}{4}$  by  $20\frac{3}{4}$  inch deep-well pump, delivering a flow of 28 gallons per minute. Two acres of land were irrigated per day of ten hours, in which time  $3\frac{1}{2}$  gallons of gasoline were consumed. The land is used for truck raising and is irrigated every twelve days in dry weather, requiring from 6 to 8 irrigations per year.

*McDowell farm.*—This farm of 4 acres adjoins the Grissett place and is irrigated with water from a pumped well 100 feet deep. A 1.5-horsepower gasoline engine drives a 2.75 by 10 inch deep-well pump 44 strokes per minute. The depth to ground water is 44 feet 8 inches, the water being discharged into a wooden tank 5.5 feet deep, 8.75 feet in diameter at the bottom, and 7.5 feet in diameter at the top. A windmill also furnishes a small additional supply. The pump and windmill together deliver 2,800 gallons of water in 2.33 hours on an average. Starting with the tank full and the pump running 1.5 acres can be irrigated in ten hours. Truck is irrigated once a week in dry weather.

*Koon plant.*—W. T. Koon leased 5 acres of improved land for one-half of the crop. The land is irrigated every ten days, from 0.5 to 1 acre of land being irrigated per day. On the land is a reservoir 6 feet deep, 46 by 62 feet top inside measurements, with side slopes of 1 vertical to  $1\frac{1}{2}$  horizontal. The water supply is furnished from an 80-foot well dug 6 feet square, the distance to water being 40 feet. A deep-well pump driven by a 3-horsepower gasoline engine supplies the necessary water.

*Holliday plant.*—Mr. Holliday has an irrigated farm on which is a well 320 feet deep, the water standing 40 feet below the ground level, and it is said that at 50, 70, 90, 120, 180, 240, and 320 feet water strata were encountered. This is the deepest well in Bee County.

*Bowen farm.*—J. J. Bowen has a small irrigation plant which derives its water supply from wells pumped by windmills. The water is discharged into a tank 53.5 feet top diameter, 5 feet deep, side slopes 1 vertical to 2 horizontal. Considerable difficulty was experienced in making the reservoir hold water. To prevent seepage, 6 barrels of crude oil were applied in two coats to the reservoir, the cost of the oil being \$20. This was not wholly successful.

*Mock farm.*—Mr. Mock irrigates a small tract of land with water pumped from a  $5\frac{3}{16}$ -inch well, 93 feet deep. The ground water stands without flow 50 feet below the level of the ground. A  $2\frac{3}{4}$  by  $13\frac{1}{2}$  inch deep-well pump is submerged 34 feet, the pump being

driven by a  $1\frac{1}{2}$ -horsepower gasoline engine. A windmill can be connected to the pump in place of the engine. The water is discharged into an earth tank 38 by 45 feet inside top measurements, side slope 1 vertical to 2 horizontal. The tank is 5 feet deep and is coated with the following combination: Twelve parts ashes, 8 parts sand, 1 part lime, and 0.4 part salt. This is put on as a mortar. After hardening it is given a coat of oil or coal tar. The well has a limited capacity, and when the engine is operated only a small part of the pump capacity is obtained. The cost of apparatus is as follows:

12-foot windmill .....	\$60
30-foot tower, erected .....	25
2-horsepower gasoline engine.....	135
Deep-well pump .....	25
Gasoline tank .....	8
Shed.....	15
Well.....	70
Pipe .....	48
Setting up engine .....	10
Reservoir .....	75
<b>Total .....</b>	<b>471</b>

*Elliott plant.*—Mr. Elliott irrigates a small farm with water pumped from wells by two 10-foot windmills operating one 3 by 8 and one  $3\frac{1}{2}$  by 8 deep-well pumps. The water is pumped into an earthen tank with a top diameter of 53 feet, side slopes of 1 vertical to 2 horizontal. In normal wind the pumps will fill the tank, which is about 4 feet deep, in from two to three days. The owner estimates that he can irrigate 5 acres with water pumped by the windmills. Truck and sorghum are the crops grown, and are irrigated every ten days in dry weather.

*Waterworks well.*—The city waterworks at Beeville derives its water supply from a  $6\frac{1}{2}$ -inch well 225 feet deep near the center of the town. The water supply is obtained from a stratum of 15 feet of water sand. The well is operated by means of an air lift, a 1.5-inch air pipe being inserted in the center of the casing. When water was first pumped from this well it delivered 55 gallons per minute; in two weeks the flow increased to 121 gallons per minute, and a day later to 146 gallons per minute. One month after starting the well gave 123 gallons per minute and shortly afterwards 263 gallons per minute. The air pipe extended 6 feet below the end of the casing. The air pressure supplied under these conditions was 50 to 55 pounds per square inch. With the air pipe at this depth considerable sand was pumped from the well. The air pipe was subsequently shortened to a length of 210 feet, at which depth 45 pounds

of air pressure are required, delivering a flow of 234 gallons per minute.

*Coleman-Fuleton Pasture Company.*—This company owns 170,000 acres near Gregory, extending practically to the Gulf. The land, much of which is quite level, is used entirely for stock raising, and as yet there has been no attempt at irrigation. In places it has been found necessary to put in surface-drainage ditches to handle the surplus rain water. Several wells have been bored for stock water, but these are all of small capacity. Near the eastern part of the ranch Chiltipin Creek empties into Aransas River, the basin at this point being about a mile wide and fully 20 feet deep. Chiltipin Creek channel, to which the flow of water is mainly confined, except during freshets, is about 10 feet below the bottom of the creek basin and at its mouth is about 3,500 yards wide. About a mile from the mouth of the creek is a 10-foot dam across the river channel, which backs the water up 20 miles. The bed of Aransas River is also very level, and it has been estimated that a dam across the river basin would furnish a storage 40 miles long, 0.25 mile wide, and 20 feet deep, and that Chiltipin Creek would furnish a storage 20 miles long, 0.125 mile wide, and 20 feet deep. Aransas River is 75 miles long, its drainage extending through a distance somewhat less than 10 miles on either side near the mouth, while Chiltipin Creek, which is 35 miles in length, has a drainage area of about one-half this width. If these figures are correct they would give a storage for Chiltipin Creek of 32,000 acre-feet and for Aransas River of 128,000 acre-feet, and, allowing 18 inches of stored water for the irrigation of land, they would together irrigate 106,167 acres. Assuming 10 per cent of the water which falls as the run-off of the land and 30 inches of rainfall, this would call for a drainage area of 1,000 square miles which would apparently be available. The figures given, however, are not the results of measurements, but are based on observations by those familiar with the country. An accurate survey would, of course, be required to definitely determine the feasibility of such an undertaking as damming the river. The water in Chiltipin Creek runs about thirty days in the year and in Aransas River for six months of the year. The possibility of the storage of water which this exemplifies is certainly worthy of careful consideration, owing to the vastly increased value of irrigated over unirrigated land.

#### CORPUS CHRISTI AND ALICE.

The supply of water near Corpus Christi consists of (1) the Nueces River, (2) drainage from the land into Oso Creek, and (3) pumped wells. Nueces River can not be depended upon to furnish a continuous supply of any extent throughout the year. Oso Creek

runs in wet weather only. The pumped wells so far developed which furnish a reliable supply of water are of small capacity. In an attempt to find artesian water a well was bored 1,730 feet and artesian water encountered, but it was so strongly impregnated with sulphur and salt that it was impossible to use it for irrigation. At 540 feet sulphur water was found, and at 1,440 feet there was a strong flow of salt water which had a head of 90 feet above the ground. Numerous surface wells have been sunk for irrigation purposes, but these are all of small capacity and operated mainly by windmills.

Three irrigation projects have been talked of which would involve the storage of rain or river water, but nothing has ever been seriously attempted in the construction of the reservoirs. Oso Creek drains a country 25 miles long and 20 miles wide, and at its mouth opens out into a large shallow lake, about 5 square miles in area, lying next to the sea, but is seldom filled with water. The soil in the bottom of the lake is of a sandy alkaline nature. It has been proposed to build a levee 2 miles in length to make this lake serve as a storage basin for rain water, an average depth of 10 feet being obtainable in this manner.

Another proposition is to erect a dam across the creek a short distance above where it widens out into the lake. The plans which were made involved the erection of a dam 2,200 feet long, built with a masonry section 500 feet long, 26 feet maximum depth, and resting on clay 6 feet below the surface, the remaining 1,700 feet to consist of an earth fill. Four hundred and fifty feet of the masonry part of the structure was to serve as a spillway, the maximum depth being 20 feet. This dam would store about 12,000 acre-feet of water.

The third project involves the damming of Nueces Bay. The Nueces River empties into Nueces Bay, a large shallow sheet of water 2 to 3 feet deep and 20 square miles in area (fig. 59). When the river is very high the water in Nueces Bay, and even for some distance beyond, opposite Corpus Christi, becomes so fresh that it is potable. At the mouth of Nueces Bay, where it joins Corpus Christi Bay, the San Antonio and Aransas Pass Railroad crosses a trestle  $1\frac{1}{2}$  miles long. Numerous proposals have been made to make this bay serve as a reservoir by building a low levee across the bay near the railroad trestle. Much of the land near the bay is very low, and, in consequence, were a reservoir to be constructed it would necessitate many miles of levee in addition to the levee crossing the mouth of the bay. The Nueces River itself near the coast has very little fall for many miles and before entering the bay the river channel is narrow and deep, the result being that when the river is at all high it floods considerable land. In connection with the proposed dam, it was esti-

mated that even though the water level in the bed should be raised only 2 feet, 10,000 acres would be flooded. The bottom of the bay is composed of black, sticky mud and oyster shells. Only careful surveys could determine the feasibility of such an undertaking, but a shallow reservoir would be open to many objections. Evaporation losses would be heavy and, in addition, the danger of contamination by salt would be very great. The plan proposed for the reservoir called also for 10 miles of embankment 2 feet high, and it was the intention to run the water within 1 foot of the top. This is entirely

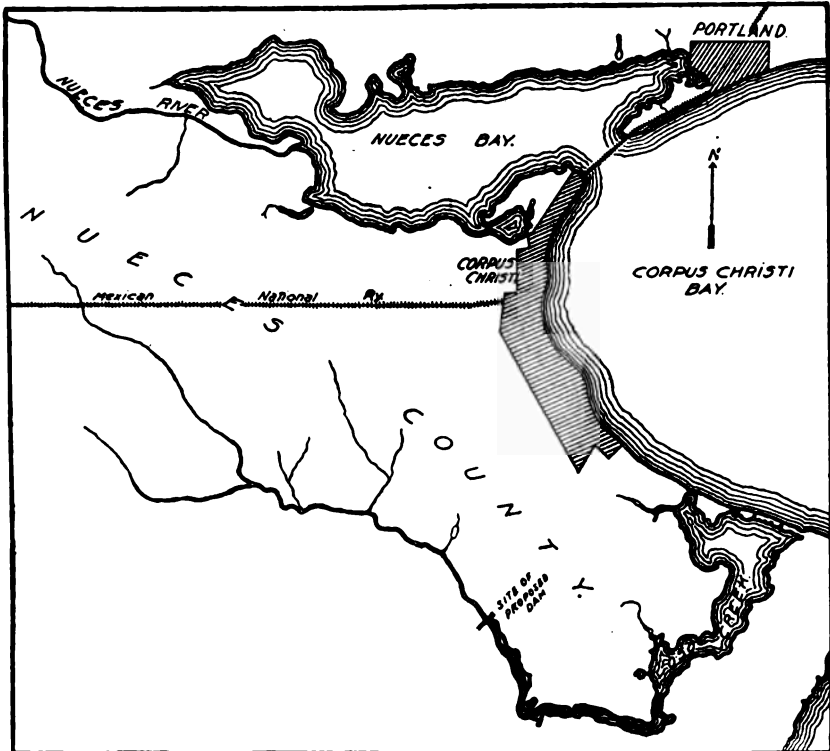

FIG. 59.—Map of Corpus Christi Bay.

too little margin to allow, as the waves would probably wash the levee out. In order to irrigate any quantity of land from Nueces Bay the water would have to be pumped against a head of 40 to 70 feet.

The land near Corpus Christi is very productive, and in good years irrigation is not a necessity. However, the benefits of irrigation in the insurance against loss as well as in the increased returns are greatly appreciated, as shown by the high rates paid for water. The customers of the Corpus Christi waterworks, in spite of the high water rates, as a rule think the results accomplished justify the expenditure. Cabbage and cotton have been two of the most

successful crops grown at Corpus Christi, the returns from the former being exceptionally large in 1904. Some of the cotton land produced 1 to 1.5 bales per acre, but the boll weevil cut down this yield materially.

The irrigable land near Corpus Christi starts from the bluff on which a part of the city is situated, some 20 to 40 feet above the sea level. The land is fairly level, with a sufficient slope, however, to be irrigated advantageously, and in some places it has been necessary to construct drainage canals to dispose of the rain water. Several small irrigated farms near Corpus Christi derive their supply from pumped wells, the usual motive power for driving the pump being a windmill. The quantity of water obtained from these wells is limited and inclined to be brackish. The wells are mostly open bottom, and the water is usually found in gray sand.

The city waterworks of Corpus Christi obtain their water supply from the Nueces River, the pumping station being situated at Nueces-town, about 16 miles from Corpus Christi, at which point the Nueces River is about 150 feet wide and 8 feet deep. A short distance below the power station a wooden dam has been constructed across the river channel, rather to keep the salt and fresh water separated than to serve for storage purposes. The actual storage basin of the river itself is some 25 miles long, due to a very gradual slope. The pump station delivers water through a 10-inch pipe into a standpipe in Corpus Christi. In several places along the pipe line this water has been used for irrigation purposes. The friction in the pipe adds very greatly to the head against which it is necessary to pump. The company furnishes water for irrigation from the pipe line at \$75 per 500,000 gallons, the water being sold in these units only. Water for stock is furnished at \$14 per farm per year. This charge of 15 cents per 1,000 gallons for irrigation purposes is so high that the most careful means of utilizing the water are employed. Iron pipe and canvas hose are used for distribution, the water being allowed to run freely out of the hose, which is moved as soon as the ground is irrigated.

*Huff farm.*—H. T. Huff irrigates 35 acres with 500,000 gallons of water per irrigation, 3-inch canvas hose being used for the work. Cabbage received two irrigations and peas one. According to these figures, the depth per irrigation was only slightly over one-half of an inch. Irrigation was carried on in March and April. The cost per year per acre irrigated was \$5.

*Kleberg farm.*—Robert Kleberg irrigated 15 acres of fruit and truck four times at a cost of \$10 to \$15 per acre, which corresponds to a depth of 2.5 to 3.7 inches per annum.

*Trott farm.*—Mr. Trott irrigated 8 acres of cabbage with 2,000,000 gallons of water from the pipe line of the Corpus Christi water-

works, the ground receiving four irrigations and the depth per irrigation being 2.3 inches. Thirty thousand to 75,000 gallons of water were used per acre per irrigation, depending on the condition of the soil.

*Noakes farm.*—N. Noakes owns 10 acres near Nuecestown, which were planted to cabbage in 1904. The land is situated on the bank of the Nueces River and water was pumped by a No. 5 centrifugal pump driven by a gasoline engine, utilizing 5 gallons of fuel per day of ten hours' run. The lift averaged 9.5 feet. The volume of water discharged was approximately 250 gallons per minute. Seven acres were irrigated, water being applied twice, the first time requiring eight days' run of ten hours each and the second six days' run of ten hours each. The furrow system was used, the furrows being of lengths varying up to 600 feet and the stream of water being divided between seven furrows.

*Fowler farm.*—Mr. Fowler irrigates a small tract by means of rain water collected in reservoirs formed by damming the natural draws. Water is also pumped from a  $5\frac{3}{8}$ -inch well 178 feet deep, provided with a strainer of  $4\frac{1}{2}$ -inch casing 8 feet long, in which are drilled three-eighths inch holes, the lower end of the strainer being set in clay. Water was found in a sand stratum and is somewhat impregnated with sulphur and iron. It stands 9.5 feet from the surface and does not rise above the 9-foot level. It is raised by a pump set in a pit 18 feet deep.

*Everhardt farm.*—The well on this farm is 150 feet deep and has an open bottom. It starts with a  $5\frac{3}{8}$ -inch casing and ends with 3-inch. The level of standing water in the well is 16 to 23 feet below the ground. A windmill operates a 2.5 by 6 inch deep-well pump, which, at 40 strokes per minute, lowers the water level in the well 6 feet. This corresponds to a flow of about 5 gallons per minute.

*Heath farm.*—Captain Heath irrigates 4 acres with water pumped from a well 182 feet deep. The well starts with  $6\frac{3}{8}$ -inch casing and ends with 4-inch. A 12-foot windmill drives a deep-well pump  $\frac{1}{2}$  by 8, delivering about 6,000 gallons per day. A supply of good water is obtained at a depth of 182 feet in 6.5 feet of sand, below which are 18 inches of clay and 10 feet of sand, these three strata being overlain by one of rock.

*Knox farm.*—Mr. Knox irrigates his land from a  $4\frac{1}{2}$ -inch well 150 feet deep, the supply being in 7.5 feet of water sand and the distance from the ground to the surface of the water 23 feet. A 12-foot windmill drives a 2.75 by 12 inch pump.



## ALICE.

From the coastal country near Corpus Christi to the Rio Grande for a distance of 50 to 60 miles inland the ground is very level. From Corpus Christi to Alice the rise is very gradual, the elevation at Alice being 210 feet above the sea. Little irrigation is carried on near Alice, the water supply being derived from pumped wells of limited capacity. At a depth of 600 to 640 feet a fairly good water stratum is found, in which the water rises to a level of 30 to 40 feet below the ground. In the surface wells near Alice the first water sand is encountered between 90 and 125 feet.

The San Antonio and Aransas Pass Railroad has a pumping station operating four wells 210 feet deep with 6-inch casing, each provided with a single-acting 3 by 18 inch deep-well pump. These pumps are all operated from the same shaft, and when run at a speed of 40 strokes per minute, delivering 88 gallons per minute, the water level is lowered 15 feet. Without flow the water stands 115 feet below the ground. The wells are 12 feet apart.

An 8-inch well near by delivers 125 gallons per minute. At Alice the Texas-Mexican Railroad has a 5-inch well 800 feet deep, from which water is raised by a direct-connected steam deep-well pump. The level of the standing water in this well is 40 feet. At 150, 300, and 450 feet water-bearing strata were encountered, at which points the casing was perforated. The water is somewhat brackish. The rate of discharge of the pump is 26 gallons per minute.

**SOUTH OF THE MEXICAN NATIONAL RAILROAD.**

The elevation of Alice is too great to obtain an artesian flow of water. The general slope of the country is toward the south and east and the nearest artesian wells are close to the Santa Gertrudas ranch, about 25 miles south of Alice. Eighteen miles southeast of Alice Mr. Weill has a well 970 feet deep, in which water stands 15 feet below the surface. Nine miles south of this well and about 6 miles north of Kingsville is a flowing well 500 feet deep, delivering 25 gallons per minute. As a general rule the flow of the wells increases toward the south and east. This is mainly due to the fact that the ground strata slope in this direction more rapidly than the ground itself, resulting in wells having a higher static pressure above the level of the ground and therefore greater flows. At the same time the wells toward the southeast become deeper. In boring wells in this vicinity many water strata were encountered which are unfit for use on account of sulphur or salt. This is particularly true toward the coast, as at Corpus Christi, where artesian strata are encountered at great depth, but the water is so strongly impregnated

with sulphur and salt it is unfit for use. The sand in which artesian water is found in this country is rather fine and of a brown color, overlaid by a thick bed of reddish-brown clay. Artesian sand strata are usually 15 to 40 feet thick and on the Santa Gertrudas ranch are, as a rule, 400 to 600 feet below the surface.

The majority of the wells are of  $5\frac{3}{8}$ -inch casing and 500 to 1,200 feet deep. Some are open bottom, but most of them are provided with strainers made of sections of pipe small enough to fit inside the casing and drilled with a number of three-eighths or one-half inch holes. A strainer commonly used consists of a joint of  $4\frac{1}{2}$ -inch casing, in which six three-eighths inch holes are drilled in the circumference, the rows of holes being 3 to 12 inches apart. The strainers have their lower ends set in the clay beneath the water sand and project into the well casing. They are not provided with either gauze or wire. On account of the danger of the clay above the water strata caving, wells with strainers of this nature are preferred to those with open bottoms. Strainers with holes of this size, however, will scarcely keep out the sand, and the result will be, as pointed out in the discussion of wells, that the lower part of the strainers will fill with sand and the entire water supply enter the casing through the upper holes only.

The wells are all put down with hydraulic rigs, a 2-inch drill pipe with a bit on the end being used in boring, as already described. These boring rigs are usually operated by gasoline engines, though some utilize horsepower. Forty feet of well are ordinarily made in a day, the rigs operating during the daytime only. In boring 6-inch wells two 6 by 6 inch single-acting pumps are used for supplying water to the drill pipe. These pumps run at 40 revolutions per minute and operate under a pressure of 35 to 40 pounds, and deliver a flow of about 60 gallons per minute for wells of this size. About 1,500 gallons of water per day are needed to compensate for seepage losses in drilling. A 9-horsepower gasoline engine used to supply power for drilling and pumping consumes 6 gallons of fuel in twelve hours.

The land in this part of the country is all in large holdings, which in the past have been used for cattle raising. The two largest ranches belong to Mrs. M. H. King and John Kenedy, and each contains in the neighborhood of 1,000,000 acres. The Santa Gertrudas ranch of 600,000 acres, starting about 18 miles south of Alice, and El Sauz ranch of 400,000 acres, situated some 50 miles north of Brownsville, are both the property of Mrs. King. The Kenedy ranch lies between these two tracts, extending toward the coast. E. C. Lasater and Maj. J. B. Armstrong are also large landholders in this section.

The country is practically devoted to cattle raising. About 15 acres of ground are required per head of stock. Artesian wells have been sunk mainly to supply water to stock, but the possibilities of irrigation are beginning to be better appreciated, and there is a general tendency to undertake the irrigation and farming of the land. The static head above the level of the ground in the artesian district varies from a few feet up to 50 feet. The static level of the water from the artesian wells is, however, by no means the same through this country, as may be seen from the following statement of wells along the line of the "Sap" Railroad from Alice south:

*Variations in the static level of the water from artesian wells.*

Distance from Alice.	Elevation of ground.	Static level of water.	Depth of well.
19.0	158	-10	468
27.5	155	+ 4	475
36.3	114	+15	568

The St. Louis and Brownsville Railroad, which was completed last July, runs within 3 miles of the headquarters of the Santa Gertrudas ranch. Kingsville is the nearest railroad station, and the country adjoining the station has been laid out as a town site. Land in this vicinity, which was worth little a few years ago, is selling at \$15 to \$25 per acre. The conditions of the sale of this land are that any individual purchasing 40 acres or more of land is allowed to sink an artesian well for the irrigation of the same. These wells, however, will be put down by the King Ranch Company, and the purchaser of the land is to pay the company the cost of sinking the well. The purchaser is entitled to utilize as much of the flow of the well as he may need, but the surplus flow belongs to the King Ranch Company, and consequently the purchaser is not allowed to dispose of the same. The idea of the company itself putting down the wells is to be commended not only on the ground that it can do the work more cheaply than individuals, but particularly since only competent drillers will be employed in boring wells.

The land near the Santa Gertrudas ranch is of a black waxy nature, the soil being about 2 feet thick, underlain with a stratum of clay. The land is covered with a growth of mesquite and costs from \$5 to \$15 per acre to clear. In going toward the south the soil gradually becomes more sandy, finally changing to a sand belt 50 miles wide, which extends down to El Sauz ranch. The rate of discharge of the wells is between 25 and 300 gallons per minute, the larger wells in this part of the country being on the Kenedy ranch. These figures were obtained by measurements made by the writer. Over 100 artesian wells have already been sunk in this district near the Santa Gertrudas ranch. A few of the wells are provided with

storage reservoirs and the water of the same is used for irrigation. A measurement of Santa Gertrudas well No. 3 near the ranch house showed a flow of 81 gallons per minute. This well is 565 feet deep. The well at the railroad station at Kingsville gave a flow of 113 gallons per minute.

#### KENEDY RANCH.

This ranch lies mainly in the sand belt, which is sparsely covered with a growth of oak and a few mesquites. Owing to the country being so open it is estimated that 10 to 12 acres are required per head of stock. The lands are covered with a variety of grasses, including considerable wire grass. The sandy surface soil is 4 to 6 feet deep and underlain with a stratum of yellow clay. The largest wells in this district are on this ranch. The following are the data of the various wells, the flow of each having been measured or estimated by the writer.

*Paistle well No. 1.*—This well is 700 feet deep, with 200 feet of  $5\frac{3}{8}$ -inch and 500 feet of  $4\frac{1}{2}$ -inch casing. The strainer is 22 feet long and the artesian sand stratum is 40 feet thick. The discharge of the well is 250 gallons per minute.

*Miflin well.*—This well is 740 feet deep, with 371 feet of  $6\frac{3}{8}$ -inch, 395 feet of  $5\frac{3}{8}$ -inch, and 60 feet of  $4\frac{1}{2}$ -inch casing, the latter including the strainer, which is 22 feet long. The thickness of the water sand is 22 feet. The estimated flow is 180 gallons per minute.

*Esteranza well.*—This well is 747 feet deep, with 340 feet of  $6\frac{3}{8}$ -inch casing, 385 feet of  $5\frac{3}{8}$ -inch casing, and 60 feet of  $4\frac{1}{2}$ -inch casing. The thickness of artesian sand stratum is 30 feet. Estimated flow, 260 gallons per minute.

*Bariosa well.*—This well is 700 feet deep. There are 411 feet of  $6\frac{3}{8}$ -inch casing, 225 feet of  $5\frac{3}{8}$ -inch casing, and 160 feet of  $4\frac{1}{2}$ -inch casing. The water-bearing sand is 22 feet in thickness. Estimated flow, 240 gallons per minute.

*Serpa well.*—The depth of this well is 617 feet. There are 60 feet of  $6\frac{3}{8}$ -inch casing, 460 feet of  $5\frac{3}{8}$ -inch casing, and 180 feet of  $4\frac{1}{2}$ -inch casing, the strainer being 22 feet long, and the thickness of the artesian sand, 38 feet. Measured flow, 307 gallons per minute.

*Turcott well.*—This well is 787 feet deep. There are 425 feet of  $6\frac{3}{8}$ -inch casing, 247 feet of  $5\frac{3}{8}$ -inch casing, and 258 feet of  $4\frac{1}{2}$ -inch casing. The strainer is 22 feet long, and the thickness of the artesian sand belt 38 feet. The estimated flow of the well is 300 gallons per minute. While boring this well a flow of 25 gallons per minute developed at a depth of 600 feet, coming from a 10-foot stratum of sand. The casing, however, was not perforated at this point.

*Alegos well.*—This well is 865 feet deep. There are 560 feet of 5 $\frac{3}{8}$ -inch casing, 700 feet of 4 $\frac{1}{4}$ -inch casing, and 100 feet of 3 $\frac{1}{2}$ -inch casing. The thickness of artesian sand was 22 feet; the measured flow 212 gallons per minute.

*Arabia well.*—At a depth of 647 feet the first artesian flow of 25 gallons per minute was encountered in this well from a 16-foot sand stratum. At a depth of 200 feet greater a second flow of about 100 gallons per minute developed, the thickness of artesian stratum being 17 feet, the water entering through a 4.25-inch strainer. At a depth of 900 feet the third flow developed 200 gallons per minute. This stratum of artesian sand is 22 feet thick and water entered the casing through a 3-inch strainer. On this ranch near the coast the depth of the first flow of water was 1,000 to 1,350 feet, with a sand stratum 22 feet thick. The other artesian sand strata are too deep to be reached by the wells. One well was finished with 3.5-inch casing at a depth of 1,512 feet. In drilling a well three-fourths mile from the ranch house, when the drill entered the water-bearing stratum from which the ranch wells derive their supply the water from the latter became muddy and gushed out, carrying considerable quantities of clay and sand, although it had been running clear for two years.

#### ARMSTRONG RANCH.

South of the Kenedy ranch is the cattle ranch of Col. J. B. Armstrong, consisting of 50,000 acres. The following are descriptions of some of the wells on this ranch:

*Katherine well.*—This well is 730 feet deep. There are 500 feet of 6.25-inch casing and 230 feet of 4.25-inch casing in the well, which has a flow of 60 gallons per minute. The quality of the water is good. The owner thinks that at 800 feet a larger supply of water would be available.

*Comal well.*—Five miles north of Katherine is the Comal well, which is of 3-inch casing, 820 feet deep. The flow is 100 gallons per minute.

*Marana well.*—This well, which is 2 miles west of Katherine, is 500 feet deep and has a 2.5-inch casing. The flow is 20 gallons per minute.

*St. Thomas well.*—Three miles southwest of Katherine is this well, which is of 2.5-inch casing 500 feet deep and has a flow of 20 gallons per minute.

On this ranch are 15 surface wells which have a good quality of water. The wells are open bottom, with 3.5-inch casing, and are pumped by 8 and 10 foot windmills. A 10,000-gallon cistern in connection with each well provides ample water for 1,000 head of cattle. The ranch land is slightly rolling prairie, covered with

sandy soil to a depth of 4 to 6 feet. The clay subsoil is 6 feet thick, below which is 4 feet of sand, 6 feet of clay, and 20 feet of coarse water sand, from which the surface wells derive their supply. In ordinary years the surface wells furnish sufficient water for stock, surface water standing 12 feet below the ground, but in dry years the supply almost gives out. At a depth of about 40 feet below the surface a stratum of salty water is encountered.

#### EL SAUZ RANCH.

South of Colonel Armstrong's ranch is El Sauz, the lower of Mrs. King's ranches. At the ranch house is a well 1,462 feet deep with a measured flow of 127 gallons per minute. The well has 800 feet of  $5\frac{3}{8}$ -inch and 600 feet of  $4\frac{1}{4}$ -inch casing. Several artesian strata were encountered while sinking the well, but as they were salt they were not utilized. There are 8 feet of perforated casing in the well. The water tastes strongly of soda. A reservoir of 170 feet mean diameter and 5 feet deep is being constructed to serve as a storage for well water, which will be used for the irrigation of a small tract. Nine miles north of the ranch is a well 1,300 feet deep with a flow of about 50 gallons per minute. This is open bottom, the casing being reduced to 2-inch pipe, of which there is 60 feet. The water tastes of soda and corrodes the iron.

*Rosita well.*—Fifteen miles to the north is the Rosita well, which is 1,100 feet deep. The well was started with  $5\frac{3}{8}$ -inch casing and ended with 60 feet of  $2\frac{1}{2}$ -inch casing. The casing was perforated where it passed through an artesian stratum of 8 feet of sand. The estimated flow of the well is 170 gallons per minute. The water is used for stock purposes only and has formed a shallow lake of about 12 acres in area.

At Rudolph, 15 miles west of the Rosita well, the railroad company sunk a well 940 feet deep, starting with  $6\frac{5}{8}$ -inch casing and ending with 330 feet of  $4\frac{1}{4}$ -inch casing. This well is stated to have a flow equal to twice the flow of the Rosita well and is the largest on the ranch.

*Saltillo well.*—Seven miles to the northwest of Rosita is the Saltillo well, which is 900 feet deep and finished with 200 feet of  $3\frac{1}{4}$ -inch casing perforated at the water stratum. This well is estimated to deliver a flow of 75 gallons per minute.

*Noria well.*—This well is situated 6 miles north of Rudolph and is 900 feet deep, being of  $4\frac{1}{4}$ -inch casing, perforated at the water stratum. The flow is estimated to be 175 gallons per minute.

## LASATER RANCH.

E. C. Lasater owns a large stock ranch west of the Kenedy ranch and south of the Santa Gertrudas ranch on which are 12 artesian wells delivering flows of 15 to 100 gallons per minute. The depth of the wells varies from 450 to 700 feet and most of them are of  $5\frac{3}{8}$ -inch casing and open bottom. There are also about 60 surface wells, 70 to 220 feet deep, the water standing in these wells usually about 40 feet from the surface, though in some it is 100 feet from the ground level. These wells are  $5\frac{3}{8}$ -inch, open bottom, having a sand stratum 10 to 20 feet in thickness. The water is pumped by windmills attached to 4 by 6 inch and 4 by 8 inch deep-well pumps and delivering water at the rate of 10,000 gallons in twelve hours or 14 gallons per minute, which they can do with a good wind of 15 to 20 miles per hour. They lower the water when pumping at the rate of 10 to 15 feet. Shallow wells cost 75 cents to \$1 per foot, and deep wells cost \$1 per foot, the owner furnishing the casing.

Two of the wells, discharging together about 180 gallons per minute, flow into a reservoir 5.5 acres in extent and 6 feet deep. At the time of the writer's visit the seepage was so great that the reservoir would not hold water at all. Since that time it has been puddled by stock and made water-tight. Near the ranch house is a well with a flow of 90 gallons per minute by actual measurement, which discharges at present into a small tank. A larger tank, 75 by 100 yards and 6 feet deep, is being constructed in which to store well water.

About 25 miles south of the Lasater ranch is a  $5\frac{3}{8}$ -inch artesian well having a measured flow of 73 gallons per minute. Near this is another artesian well with a flow of 54 gallons per minute. These wells represent the extreme limit of proven flow. Since the writer's visit it is reported that a well recently sunk on the Lasater ranch has a flow of 300 gallons per minute.

Santa Gertrudas, Olmos, and San Fernando creeks, which flow in wet weather only, serve to carry off the drainage from a large section of country in the southern part of Nueces and Duvall counties. Earth dams have been built in places across the beds of these creeks to serve for the storage of water for stock, but high water has almost invariably carried the embankments away. While not available for the storage of any large quantities of water, still, by providing suitable wasteways, the creeks could serve as storage basins of appreciable extent.

At Duval, which is 70 miles southwest of Corpus Christi on the Mexican National Railroad and has an elevation of 390 feet, a shallow artesian well was put down, but the water was strongly charged with salt.

**RIO GRANDE VALLEY.**

The largest irrigation field in the part of Texas investigated lies in the valley of the Rio Grande. The soil is largely alluvial, having been deposited by the river waters, but its nature varies considerably, depending upon the section of the country from which the sediment has come. In general it may be said that alluvial soil requires a large amount of moisture, owing to the fact that it is exceedingly deep and porous and has a tendency to crack after irrigation.

The irrigable land lying along the river is in somewhat limited areas from Del Rio to a point 15 miles above Hidalgo, where the low-lying part of the valley widens out considerably. From this point to the coast the area of irrigable land increases considerably. About 10 miles from the coast the land becomes so alkaline that it is unfit for use. Apprehension has been felt at certain points along the river as to the effect of this alkali upon crops, but no reliable information upon this matter is to be obtained. The lift from the river to the irrigable land increases rapidly at first as one ascends the river, varying from 12 feet to practically nothing at high water at Brownsville, while near Laredo it is 60 feet.

About 12 miles above Del Rio, Devils River empties into the Rio Grande. Devils River, which runs through a canyon of limestone formation, has a fall of 700 feet in 70 miles. A measurement of the flow of the river, made August 2, 1904, at a point a few miles north of the Southern Pacific Railroad, gave a discharge of 324 cubic feet per second. The crest of the hills on either side near where the Southern Pacific railroad crosses the river is at such an elevation and so far distant that it is improbable that water from the river will be used for irrigation.

Near the town of Del Rio are several springs of considerable capacity, which have been used for irrigation for a number of years, but which will be further utilized by the Del Rio Irrigation Company, of which G. B. Moore, of San Antonio, is president, through what is perhaps the most costly irrigation enterprise of the State. The San Felipe Springs, a short distance from the town of Del Rio, deliver a flow of 70,000 gallons per minute. About thirty-five years ago the San Felipe Agricultural Company built a ditch, through which until recently they utilized water from the springs for the irrigation of a considerable tract of land. The company consisted of the land-owners, who operated the ditch at a cost of about \$1 per acre per annum. No charge was made for water from the springs, of which a great part ran to waste. John Twohig was the original owner of the springs and gave them to a priest, from whom they eventually passed into the control of Mr. Moore. In the meantime he had



bought sufficient shares in the old ditch company to obtain control of that, whereupon he formed the Del Rio Irrigation Company, and water for irrigation was furnished to the stockholders of the old ditch company at \$5 per acre per annum. This, of course, raised a storm of protest from the landowners, and as a compromise measure the price was temporarily cut down to \$2.50 per acre per annum.

In order to utilize to the best advantage the full capacity of the springs the Del Rio Irrigation Company has undertaken a most expensive engineering work in the construction of a ditch to carry water from the springs some 21 miles. J. W. Maxcy, of Houston, is the engineer in charge, and the undertaking is particularly worthy of note owing to the difficulties of construction. One of the San Felipe springs has a flow of 20,000 gallons per minute, another 45,000 gallons per minute, and two smaller springs bring the total rate of flow up to 70,000 gallons per minute. The springs have a static head of 9 feet above ground. The lower level of San Felipe Creek, through which the springs discharge, was raised 10 feet by means of a masonry dam 300 feet long, 12 feet high, and containing 1,200 cubic yards of material, which cost \$4,600. The main canal is 16 feet wide on the bottom, 4.5 feet deep, and designed for a capacity of 70,000 gallons per minute. Side slopes in earth are 1 vertical to 2 horizontal; in rock, 5 vertical to 1 horizontal; in embankments, 1 vertical to 1½ horizontal. The upper part of the canal is built on a grade of 0.45 foot per 1,000 feet. The remainder will be built on a grade of 0.3 foot per 1,000. The velocity of flow in the open channel is about 2.5 feet per second.

The country through which the canal passes necessitated heavy cuts and fills, a 34-foot rock cut being necessary in one place. A considerable amount of the ditch had to be built along a sidehill, where the soil was of a treacherous nature. In the first 5 miles of canal, which was the distance completed at the time of the writer's visit, 5,000 feet of sidehill ditch had been constructed, with a concrete wall on the downhill side 18 inches thick on the bottom and 9 inches thick on top, set 18 inches into the ground. (Pl. VI, fig. 1.) Much trouble had been experienced from some of this construction owing to the banks washing out. To overcome this difficulty the canal was lined on the bottom with 18 inches of clay at points where seepage was liable to occur, and in addition a good deal more earth was thrown on the outside of the concrete walls and the canal dug farther into the bank. As the country is subject to rains of considerable violence, much attention was paid to rendering the canal safe from accidents due to such storms. Where a large quantity of water is liable to be carried down a draw the canal water is taken under the ground in inverted siphons of 5 feet inside diameter, built of reinforced concrete 9 inches thick. At other places where the canal is carried across



**FIG. 1.—DEL RIO CANAL, TEXAS. SIDEHILL CONSTRUCTION, WITH CONCRETE OUTER WALL.**



**FIG. 2.—DEL RIO CANAL, TEXAS. REINFORCED CONCRETE PIPE IN COURSE OF CONSTRUCTION.**

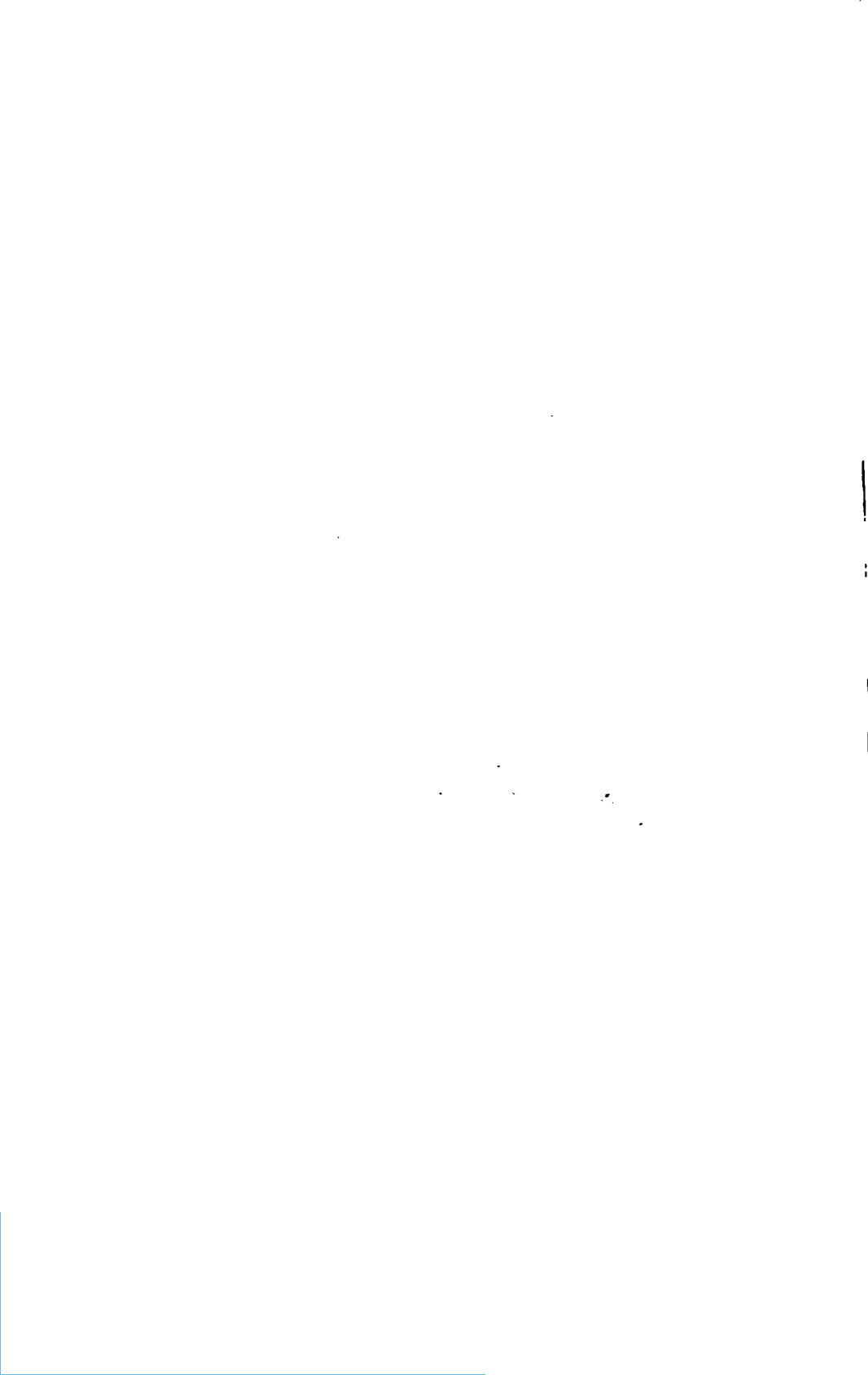

small draws provision has been made for passing rain water underneath by means of suitable underdrains. Figure 60 shows a cross section of a concrete pipe which was reinforced by 0.5-inch steel corrugated bars, running both lengthwise and around the pipes, set 1 foot apart. Plate VI, figure 2, shows the reinforced concrete pipe in the process of construction. An inverted siphon 2,200 feet long will carry the water under Sycamore Creek. In addition to the use of concrete pipe for inverted siphons, a considerable quantity was

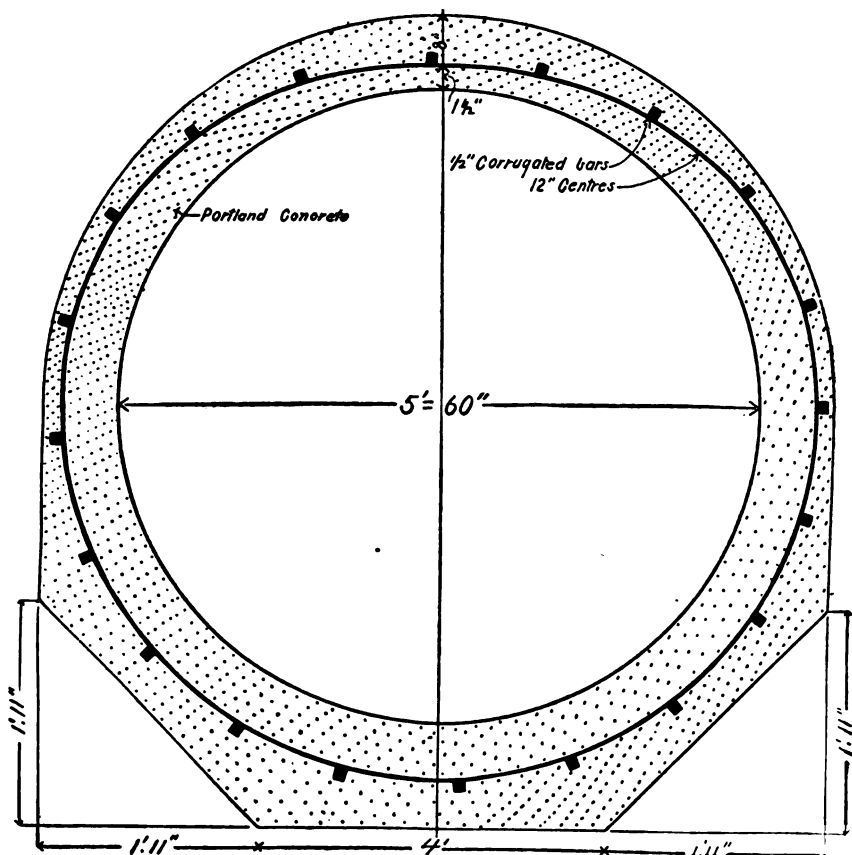

FIG. 60.—Cross section of reinforced concrete pipe.

utilized in places for sidehill construction. This pipe was laid on a grade of 4.5 feet per 1,000 and has a theoretical capacity of 70,000 gallons per minute.

The work involves 90,000 cubic yards of solid rock excavation, 120,000 cubic yards of loose rock, and 1,750,000 cubic yards of earth, with 5 miles of concrete wall and 2 miles of vitrified pipe. The total length of the concrete siphons is 8,000 feet and 110 tons of steel reinforcing rods were used in their construction. Steam shovels were

used for handling the rock and digging the canal. The cost of operating shovels per day was as follows:

*Cost of operating steam shovels.*

1 engineer .....	\$5. 00
1 assistant engineer .....	5. 00
1 fireman .....	2. 00
1 coal hauler .....	2. 00
1 water hauler .....	2. 00
1 assistant .....	2. 00
2 tons of coal, at \$3.50 .....	7. 00
Total .....	25. 00

The steam shovel handled about 1,000 yards of dirt per day of ten hours or about one-half this quantity of rock, the size of the bucket being 1 cubic yard. The estimated cost of handling rock by the steam shovel was 50 cents per cubic yard, and of earth, 25 cents per cubic yard. The cost of the expanded-metal pipe, which was built of 1, 2, and 5 Portland cement, was \$4.66 per running foot in place. The wing walls were built of rubble masonry laid in concrete mortar, and cost \$6.30 per cubic yard. Head walls and aprons of 1, 2, and 5 concrete cost \$5.75 per cubic yard. Rock excavation cost 85 cents, loose rock 42 cents, and earthwork 13.5 cents per cubic yard. The concrete work was done by Mexican day labor. The total estimated cost is said to be nearly \$1,000,000, and the system will furnish water to about 15,000 acres on the assumption of a duty of 100 acres per 1 cubic foot per second.

At several points it is proposed to utilize the water for the generation of electric power, and it has been estimated that 1,200 horsepower could be developed altogether from the various falls.

A few miles east of Del Rio are the Pinto, Sycamore, and Los Moras creeks, the first two having a flow of 4,000 gallons per minute each, and the last 5,000 gallons per minute. It has been estimated that by means of storage in these creeks and the flow of the canal 40,000 acres could be irrigated, and the company has under contemplation the building of storage reservoirs. At present the water from Sycamore Creek is used for the irrigation of 300 acres by means of a 26-horsepower traction engine, which drives an 8-inch centrifugal pump, delivering 2,400 to 3,000 gallons per minute, against a head of 27 feet. The fuel consumption is 1.5 cords of mesquite in ten hours. Corn is the principal crop grown under this plant, and the bed system of irrigation is used. Forty-five days of ten hours' run each are necessary to irrigate 273 acres. About 500 acres are at present irrigated from Los Moras Creek and 350 acres from Pinto Creek by gravity.

The old ditch of the San Felipe Agricultural Company is supplied from a spring delivering 15,000 gallons per minute, which irrigate 3,000 acres of land planted as follows:

	Acres.
Corn .....	2,000
Garden truck .....	300
Rice.....	250
Johnson grass and cane.....	450

The ditch is 10 feet wide on the bottom, with nearly perpendicular sides, and water runs 3 feet deep. It is 5 miles long and feeds 32 miles of laterals. The land is irrigated every fifteen days, irrigation being carried on day and night. So far the water supply has proven ample for all demands, even in dry weather. Rice is irrigated partly by flooding checks and partly by wild flooding; 45 acres are irrigated by Japanese in accordance with the practice in Japan. About 11 gallons of water per minute per acre were used on this land in 1903, and the yield was 14 bushels per acre; but it is the opinion of the company that this can be much improved. A large amount of Johnson grass growing in the rice fields was killed by the constant flooding.

The laterals under the main canal of the Del Rio Irrigation Company are 4 feet wide, 4 feet deep, and carry a depth of 3 feet of water. The grade is 0.9 foot per 1,000 feet, or twice the grade of the main canal. It is figured that they will irrigate 1,000 acres. The ditches leading from the laterals are 3 feet wide and 2 feet deep. The first 5 miles of the main canal control only 1,500 acres, most of the irrigable land lying farther down the canal.

#### CIENEGAS SPRINGS.

About 2 miles to the west of Del Rio are the Cienegas Springs, belonging to D. Hart, the water of which is used to irrigate 550 acres of Johnson grass. The land is irrigated by wild flooding once after each cutting, when there is no rain, and requires the services of two irrigators to control the flow. It takes two months to irrigate 550 acres with the full flow, utilizing the same twelve hours per day. The flow of the springs is 2,500 gallons per minute. The land produces 1 ton of hay per cutting, yielding three cuttings a year.

#### EAGLE PASS.

The Rio Grande Valley Irrigation Company's farm, situated about 3 miles north of Eagle Pass, comprises 360 acres of land belonging to Messrs. Dolch, Dibrell, and Mosheim, 300 acres of which are irrigated by water pumped from the Rio Grande. A 125-horsepower horizontal boiler furnishes steam at 90 pounds pressure to an automatic

engine of 125 horsepower, which drives a 10-inch vertical centrifugal pump, delivering 5,600 to 7,000 gallons per minute, against a lift of 46 feet. The pump is set in a pit 46 feet deep and 20 feet in diameter, the sides of which are lined with brick and cement. A tunnel 60 feet long and 4 feet square leads to the river and supplies water to a 15-inch suction pipe connected with the pump. The pump discharge pipe is also enlarged to 15 inches in diameter. Four and one-half tons of coal screenings are consumed in twelve hours and cost \$1.40 per ton. The coal comes from the Eagle Pass mines, which are close at hand. One fireman and one engineer operate the plant, which irrigates 25 acres in twelve hours.

The main ditch is 1.5 miles long, 4 feet wide on the bottom, 7 feet wide on top, 3 feet deep, and carries water to a depth of 18 to 20 inches. It has a grade of 18 inches per mile. The bed system of irrigation is used throughout, the beds being 50 feet wide and 400 to 700 feet long, flooded from ditches at the ends.

The areas and yields of crops are as follows:

*Crop on farm of Dolch, Dibrell, and Mosheim.*

Crop.	Acres.	Yield per acre.	When irrigated.	Number of irrigations.
Cotton.....	200	1 bale	Every 15 days	7
Cane.....	7	40 tons	do	10
Sorghum.....	20	4 tons	do	5
Melons.....	10		Every 10 days	
Green peppers.....	1		do	10
Corn.....	62	35 bushels	Every 15 days	5

*Pioneer Rio Grande Irrigation Company.*—Dolch and Dobrowolski irrigate 350 acres of land three-fourths of a mile south of Eagle Pass with water pumped from the Rio Grande. Two 80-horsepower boilers furnish steam to a 115-horsepower automatic engine driving a No. 10 double-suction centrifugal pump, with an extreme rated capacity of 10,000 gallons per minute. The pump normally delivers 7,000 gallons per minute and is set in a pit 36 feet deep and 30 feet in diameter, about 300 feet from the river. The suction pipe, which is 14 inches in diameter, runs into a tunnel 4 by 4 feet. The discharge pipe of the pump is 14 inches in diameter. The irrigable land lies in two sections, one of which is adjacent to the pumping station, and the other 1,100 feet distant, with an additional elevation of 8 feet. For conveying water to the higher land a 14-inch pipe is used. The head against which the pump has to operate in delivering water to the lower land is 36 feet plus the friction in the pipe, and to the upper land is 44 feet plus the friction in 1,100 feet of 14-inch pipe. In normal operation the pump will deliver 7,000 gallons by the lower and 4,000 by the upper lift. The plant consumes  $4\frac{1}{2}$  tons of Eagle Pass

coal in 12 hours. The lower bench requires much more water than the upper, as the soil is more sandy; and the pump is able to irrigate about the same quantity of land in either bench in a day's run. Twenty acres of onions can be irrigated in twelve hours, or 25 acres of other land in the same period, with the entire flow of the pump. The soil is a light alluvial sandy loam, very deep, and bakes but little when irrigated. Seventy-five acres were planted in onions, yielding 19,500 pounds per acre, irrigated every ten days; 15 acres in cane; 20 acres in sorghum; 47 acres in corn; 20 acres in truck, irrigated every ten days; 40 acres in alfalfa, irrigated every fifteen days, twice for each cutting. The alfalfa yield was three-fourths of a ton per acre per crop, and six crops per year, cut between the middle of April and October; 5 acres planted in fruit, and 5 acres in melons, the remainder, 123 acres, being in Johnson grass. The onions received altogether twenty-one irrigations; the cane, sorghum, and corn received eight irrigations each. The onions were planted 5 inches apart in rows 12 inches apart. They were irrigated by the bed system, the beds being 30 by 150 feet, and were planted October 20, transplanted December 1, and harvesting commenced April 25. No fertilizer was used on the onion land. One man irrigated 2 acres of onions per day and from 4 to 5 acres of other crops in the same period. Eighty men were thirty days transplanting the onions, and 100 men twenty days in harvesting them. The onions sold for \$1.75 per hundred f. o. b. Eagle Pass. The bed system of irrigation is used for all irrigation.

*The A. B. Frank ranch.*—Eighteen miles to the southeast of Eagle Pass is the ranch of A. B. Frank. Fourteen hundred acres of land is under irrigation by water pumped from the Rio Grande. Two horizontal multitubular boilers, 60 inches in diameter and 18 feet long, deliver steam, under 150 pounds pressure, to a 500-horsepower Corliss engine, 20 by 42 inches. A surface condenser is used, and a vacuum of 25 inches is obtained. The engine drives a 24-inch centrifugal pump, supplied with water through a tunnel 5 feet wide and 5 feet high, arched on top. The power house is situated on the making bank of the river, and the tunnel is inclined to fill with sand. The pump delivers 12,000 gallons per minute against a 52-foot lift, and water is discharged into a flume 612 feet long, 6 feet wide, and 3 feet deep. One engineer, 2 firemen, and 2 helpers are required for the operation of the plant per shift. The plant consumes 15 cords of mesquite in a twenty-four-hours' run, the cost of fuel being \$2 per cord, owing to the necessity of hauling the same 10 miles. The total cost of the plant, including the flume, was \$20,000, the flume itself costing \$2,000. The main canal is 8 feet wide at the bottom, 15 feet at the top, and 3 feet deep, the crown of the banks being 30 inches. The slope is 30 inches per mile; the length, 3 miles, and the depth of



water when carrying a full discharge of the pump, 18 inches. While 1,400 acres are subject to irrigation, so far only 250 acres are irrigated, planted to alfalfa. The land had previously been irrigated by the furrow system, but is being changed to the check system, the checks being 6 inches in height. The yield of the land is  $1\frac{1}{2}$  tons per acre per cutting and from 6 to 8 cuttings per year. The plant will irrigate 60 acres in a twenty-four hours' run.

#### LAREDO AND VICINITY.

The land around Laredo, which until recently has been considered of little value, has in the last year produced some remarkable crops of Bermuda onions. While other crops have been raised here and between Cotulla and Carizzo Springs, still the yield of onions has been so great and the prices realized so high that they have easily taken first place in the products of the region. Financially the most successful section of the country in onion growing is in the vicinity of Laredo. The irrigable land in that region lies along the Rio Grande, and comprises a comparatively narrow strip extending up and down the river several miles. Some little distance back from the banks, which are 50 to 75 feet high, the land slopes toward the river on a steep grade, so that a considerable length of pipe is required to convey water to the land. The soil is of a light alluvial nature and very deep, requiring a comparatively large quantity of water for irrigation, which must be pumped from the river. The farms have been so successful that many new pumping plants are being installed and will be in condition for operation this season. The two most successful plants from the financial standpoint were those of Mr. Alexander and Mr. Nye. The former is said to have sold the onion crop from 40 acres for \$26,000, while the latter received \$9,000 for the crop from 13 acres. The yield of onions in this vicinity went as high as 40,000 pounds per acre. The ground, however, was all heavily manured. Onions were planted about November 1, transplanted a month later, and the crops were harvested in April. On the majority of the farms after the onion crop had been harvested cowpeas were planted, to be plowed under in time for the next onion crop.

*Richter farm.*—Near Laredo is a farm, owned by A. C. Richter, containing 6 acres. The ground was sown to white Bermuda onions last year and the yield was 20,000 pounds per acre. The crop was sold for \$2,500. Cowpeas were grown on the land, plowed under, and the land manured with 20 tons of goat manure per acre, as well as 1 ton cotton-seed meal, and 600 pounds of sodium nitrate put on in six applications of 100 pounds each.

The pumping plant consisted of an 8-horsepower gasoline engine driving a triplex power pump delivering 235 gallons per minute.

The lift was 65 feet. The engine consumed 1.5 gallons of gasoline per hour at a cost of 18½ cents per gallon. This plant flooded 6 acres in thirty hours. The land received 12 irrigations per season, which were applied two weeks apart at first and once a week later. Two men were required for irrigation and running the engine. The cost of labor was 50 cents per day. After each irrigation the land was cultivated. It required 30 men twenty days to transplant the onions and ten days to harvest them. Cowpeas were planted as soon as the onions were out of the ground, and received last year two irrigations. Here, as in all other plants in the vicinity of Laredo, the bed system of irrigation was used. The entire flow of the pump was turned into one bed at a time, the beds being 104 by 12 feet. The supply was stopped when the water had reached three-fourths of the way down the bed. The cost of fertilizers was: Cotton-seed meal, \$25 per ton; manure, 90 cents per ton; sodium nitrate, 3.5 cents per pound.

Onions were planted in October, transplanted in December, and crops moved April 15.

*Alexander farm.*—Near North Laredo, on the Rio Grande, is the 40-acre irrigated farm of Mr. Alexander. The pumping plant is as follows: A 90-horsepower horizontal multitubular boiler furnishes steam to a 40-horsepower engine belted to a No. 5 compound centrifugal pump set in a concrete pit 17 feet in diameter and 19 feet deep. The pump delivers 800 gallons per minute from the river against a vertical lift of 65 feet and forces the water through 1,500 feet of 6-inch pipe. The plant was operated twelve hours a day, consuming in that period 4 tons of coal, at a cost of \$1.50 per ton. It requires five days' operation of the plant to supply water for one irrigation of the land. One man was required to run the plant.

The ditch for distributing the water is 2 feet on the bottom, 5 feet on top, 18 to 24 inches total depth, and has a grade of 7.5 feet per mile. The laterals are on a grade of 4 inches per 100 feet.

White Bermuda onions were grown on the entire tract and yielded 30,000 pounds per acre, the gross yield being sold for \$26,000. They were planted October 1, transplanted in December, and harvested in April. One hundred and twelve pounds of seed were used. The frequency of irrigation was increased toward the end of the season—every fifteen days in January, every twelve days in February, and every ten days in March. Including the planting, about nine irrigations were given. Bat guano (1 ton per acre) was used for fertilizer on most of the land, though parts of it were not fertilized. Stable manure was used for the seed beds.

The bed system of irrigation was used, beds being 13 by 150 feet, with a fall of 4 inches per 100 feet. Onions were planted 4 inches apart and rows spaced 12 inches. Hand culture was employed, and

two men were required to irrigate with the water furnished by the pump. It took 60 men twenty-four days to transplant the onions and 85 men fifteen days to harvest the crop, the pay being \$5 Mexican per week of six days.

Cowpeas have been grown on the land, but without much success. Grapes are grown with tolerable success.

The soil is very deep, of a light alluvial nature, and will not retain moisture. Well water in this vicinity is decidedly brackish. Owing to sediment in the river the ditches fill rapidly. In 1892 the North Laredo Land and Irrigation Company built a ditch 3 miles long in this vicinity, which has now been cut up and is used in sections by the various ranches.

*Madrigal farm.*—Adjoining the Alexander farm is a 13-acre tract belonging to Mr. Madrigal. The irrigation plant consists of a 15-horsepower gasoline engine geared to a triplex pump delivering 300 gallons per minute from the river against a lift of 65 feet through 800 feet of 5.5-inch pipe. The engine uses 2 gallons of gasoline per hour, at a cost of 18.5 cents per gallon. Another gasoline engine of 10 horsepower, not now used, formerly ran a similar pump delivering 225 gallons on 1 gallon of gasoline per hour.

A small ditch, 20 inches wide on top and 10 inches deep, was used for conveying the water to the land, which was irrigated by the bed system, the beds being 10 by 100 feet and the entire flow being turned into one bed.

Ten acres were planted in onions and 3 in truck. The onions were irrigated every twelve days, requiring 8 to 10 irrigations during the season. They were planted October 1, transplanted November 15, and harvesting began April 1. Two and one-half to 3 acres of onions were irrigated per day of ten hours.

Truck was irrigated from August to March, partially by the bed and partially by the furrow system. The latter saved one-third of the water. The furrows were 100 feet long and 2.5 feet on centers. The flow of the pump was turned into three furrows.

Onions were planted 4.5 inches apart in rows 12 inches on centers. The yield of onions was 22,000 pounds per acre.

*Nye farm.*—Near the Alexander place is the farm of Mr. Nye, one of the oldest residents of the section, as well as a pioneer in irrigation. The farm comprises 25 acres, 23 acres being planted to onions, of which 13 were farmed by the owner and the remainder rented. The yield was considerably better on the part farmed by Mr. Nye than on the rented land. The pumping plant consisted of a 60-horsepower boiler, which supplied steam to a duplex steam pump 12 by 12 inches, delivering 900 gallons per minute from the river against a lift of 65 feet and forcing water through 350 feet of 8-inch pipe. The pump was set in a brick pit 15 feet in diameter and 15 feet deep. The fuel

used was coal, about 3 tons being required for a day's run of twelve hours. The main ditch is 4 feet wide on top and 2 feet deep.

Seed was planted October 1, 35 to 40 pounds per acre being used in the seed beds, equivalent to 3 pounds per acre after the onions were transplanted. The land was irrigated every ten to fifteen days during the season, the crop requiring 10 irrigations. For fertilizer manure from the stock yards was used, applied at the rate of 60 tons per acre, costing \$2.50 per ton. The entire onion beds of 23 acres could be irrigated in two days' run of fourteen hours each. Onions were irrigated by the bed system, the checks being 13 feet wide and 100 to 300 feet long. The smaller beds required the full flow of the pump four to five minutes and the larger beds fifteen to twenty minutes. Onions were spaced 5 inches apart in 13-inch rows. One irrigator could look after 10 acres. Transplanting 13 acres of onions required 40 men sixteen days, and harvesting the crop from the same required 40 men twenty days. The yield of the 13 acres farmed by Mr. Nye was 35,000 pounds per acre, while that of the rented land was but 15,000 to 20,000 pounds per acre.

Three acres of grapes brought \$260. Six tons of alfalfa per acre per year are raised, the land being irrigated every week.

*Johnson farm.*—Near Laredo, on the river, is the 4.5-acre farm of Mr. Johnson. A 45-horsepower boiler furnishes steam to a 12 by 14 inch steam end duplex pump delivering 770 gallons per minute from the river against a lift of 53 feet and forcing the water through 2,000 feet of 6-inch pipe. One man is required for the operation of the pump station. Fuel is mesquite, costing \$2.25 per cord delivered, and 1 cord is required for ten hours' run.

The soil is 3 to 30 feet deep and varies from a dark chocolate to a light color. The subsoil is partially rock. The land which slopes back from the river 7 feet in 0.5 mile holds moisture fairly well. It was planted to onions in beds spaced 5 inches apart, in rows 14 inches apart, and required five to eight hours run to irrigate the 4.5 acres, the flow of the pump being divided into two beds which were made 15 feet wide and 100 to 200 feet long. The onions required 8 to 10 irrigations per season and were irrigated about every ten days between December 1 and April 1. No fertilizer was used, but this year cowpeas are being grown, which will require two irrigations.

*Matteson farm.*—Mr. Matteson is installing on his farm, near Laredo, a plant for irrigating 15 acres. The plant consists of a pump station containing a 50-horsepower boiler and a 35-horsepower automatic engine belted to a No. 6 centrifugal pump discharging 1,500 gallons per minute through 400 feet of 9-inch pipe. The lift from the river is 53 feet.

*Cogley farm.*—Fifteen miles southeast of Laredo Mr. Cogley has a farm of 8 acres. The pump station has a 60-horsepower horizontal boiler which supplies steam at 80 pounds pressure to a pulsometer delivering from the river 500 gallons per minute through 700 feet of 8-inch pipe against a vertical lift of 62 feet. The fuel used was mesquite, costing 90 cents per cord, the wood being cut on the land of the owner. The consumption of fuel was 4 cords per day of ten hours, which was the length of time it took to irrigate the entire farm.

The ground was sown to onions irrigated by the bed system, the entire flow of the pump being utilized on each bed. Onions were planted in October, transplanted in December, and harvested the latter part of April. The yield was 32,000 pounds per acre. The land was irrigated every ten days and cultivated after each irrigation.

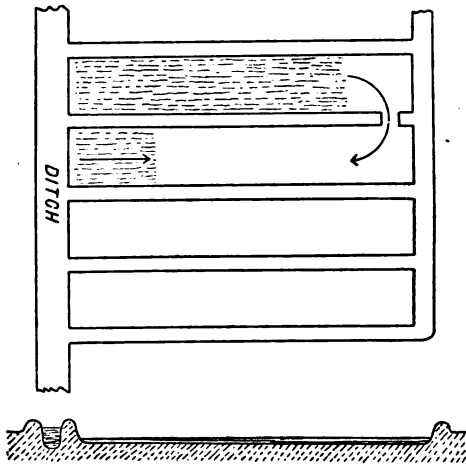

FIG. 61.—Bed Irrigation.

Two irrigators and one man to run the pump station were required. For fertilizer 200 tons of goat manure were used on the 8 acres. The soil is a light, sandy loam, very deep, with clay subsoil. From the main ditch, which is 4,000 feet long, the water enters 12-inch sewer pipes from which it is distributed to the land. Transplanting the onions took 18 men fifteen days, and harvesting required the same amount of labor. After the onion crop

had been harvested cowpeas were planted and up to the middle of July had not been irrigated.

*Harvey & Thompson plant.*—Near Laredo is a 20-acre ranch rented and farmed by Harvey & Thompson. The pumping plant consisted of an 80-horsepower boiler, supplying steam to a 6-inch pulsometer pump delivering 500 gallons per minute from the river, against a lift of 60 feet through 1,500 feet of 12-inch pipe. One man was required to operate the pumping plant, receiving 55 cents per day. Four tons of Laredo coal was consumed in a twelve-hour run, at a cost of \$1.50 per ton. The coal is of poor quality and the railroad company figures that 2 cords of wood are equivalent to 1 ton of this coal.

Thirty tons of sheep and goat manure were used per acre for fertilizer, at a cost of \$1 per ton in addition to the hauling, which was done by the tenants, and cost 40 cents per ton.

Onions were planted 4 inches apart in rows 12 inches apart. They were transplanted in December and harvested in April. The irrigation beds were 12 by 150 feet. It took the entire supply of the pump two and one-half minutes to irrigate each bed and twelve hours to irrigate 12 acres. The supply of water to each bed was stopped when the water had reached part way down and the check between the bed and the adjoining one below opened in order that the surplus water which arrived at the bottom of the bed might pass into the adjoining bed. For illustration see figure 61. Two men and a boss were required for the irrigation work. Field hands received \$2.25 per week with no Sunday work.

Fifty men transplanted 1.5 acres per day, and 60 men were required to gather, trim, pack, and load the yield from 1 acre—25,000 pounds (500 crates)—per day. In harvesting, the onions were plowed up while the tops were still green. This method, of course, destroyed a certain number of onions, but the lessees believed that the damage was more than equaled by the saving in labor over the customary method of pulling by hand. Onions yielded 20,000 to 30,000 pounds per acre, and the entire crop sold for \$12,200. The lessees estimated their net gain at \$7,500, as shown in the following statement:

Twenty acres onions.....	\$12, 200
Water and labor.....	2, 200
	<hr/>
Total gain .....	10, 000
One-fourth share to owner of plant.....	2, 500
	<hr/>
Net gain .....	7, 500

#### HIDALGO TO THE COAST.

Irrigable land in the vicinity of Hidalgo starts at a point about 15 miles upstream in a narrow strip which rapidly increases in width down to the mouth of the river. The country is filled with resacas (old river beds), some of which retain their supply of water throughout the year. The country is highest near the river and at first slopes away from the banks, gradually rising, however, to what is known as the second bench. At Hidalgo the vertical distance from the top of the river bank to extreme low water is 23 feet, the river at this point being subject to a rise of 10 to 12 feet. Land slopes also in the general direction of the river with a fall of about 1 foot per mile, the distance by river being about 2.5 times the distance by straight line. According to figures taken from a survey of the San Antonio and Aransas Pass Railroad line from Alice to Brownsville, via Hidalgo, land at the latter place is 20 feet above the average low-water stage of the river. Five and one-half miles to the north the ground falls 8 feet. Seven and one-half miles north of Hidalgo the elevation is 24 feet above the Hidalgo bank. The ground is nearly level for 6 miles,

after which it drops 15 feet in 2 miles. At Brownsville the average low-water stage of the river is 13 feet below the level of the land, while the elevation at Brownsville is 35 feet above the sea. At Santa Maria, 27 miles west of Brownsville, it is 73 feet; 43 miles west, 85 feet; 53 miles west, 110 feet. For about 20 miles north of Brownsville the ground slopes off gradually, having a fall of 18 feet in 15 miles. At the end of this distance there is an abrupt rise of 12 feet, after which the ground gradually slopes off again and then rises to the banks of the Arroyo Colorado, a stream which is usually dry. It heads a short distance above Santa Maria, and tide water extends 30 miles upstream from its mouth.

The land of the first bench, starting at the river, is composed of a light alluvial soil which cracks when it dries and when newly plowed requires a large quantity of water for irrigation. The timber is mainly mesquite, with a very heavy undergrowth. The land of the second bench is a black sandy loam and quite firm. It has not been flooded for some time and the timber is much heavier. After crossing the Arroyo Colorado the ground gradually becomes more sandy, until at the beginning of the sand belt, about 3 miles beyond El Sauz ranch and 52 miles north of Brownsville, the black sandy loam entirely disappears. Going northward the timber growth becomes lighter until it finally disappears at the beginning of the sand belt.

Until very recently labor along the river has been about 50 cents Mexican per day, or about 23 cents currency. Opening up the country, however, caused prices to rise about 50 per cent. Labor is practically entirely Mexican. Much land near Brownsville has been cleared at \$10 per acre. The usual method of procedure is to let contracts for clearing the land rather than to have the work done by day labor. Considering the nature of the land, some of which will yield as much as 8 cords of wood per acre, these figures seem exceedingly low. The clearing should pay for itself in fuel value.

Up to the past year this country was seriously handicapped in its development by lack of transportation facilities. The only means of getting supplies in was either by a 150-mile haul over sandy roads or by shipment by water to Port Isabel and transportation from there to Brownsville, 20 miles distant, over a steam railroad, which is in reality more of a tramway. Port Isabel is so situated that only light-draft boats can enter the harbor, and even these often have to stay outside in case the weather is at all rough. From Brownsville to Hidalgo, a distance of 70 miles, there is at present no railroad on the American side, though on the Mexican side a line runs from Reynosa, which is opposite Hidalgo, to Matamoros, opposite Brownsville, which has one mixed train every other day. However, there are no bridges across the river east of Eagle Pass. In July, 1904, a railroad line was completed between Robstown and Brownsville, which

was the signal for general celebration throughout the country. A branch line is at present being constructed to run near Hidalgo, which will greatly improve the prospects and conditions of the farm owners and enable them to enter into competition in the open markets.

Irrigation development in this country has been particularly marked the past few years, and now that the railroad has been completed it will be natural to look for a large increase in the products of the land. This country is one of the largest irrigation fields in the State of Texas, and the low lift, cheap fuel and labor, and early seasons all combine to make it one of the leading sections for irrigation on a large scale. The flow of the Rio Grande will not be nearly sufficient for all the irrigable land in this vicinity, but it will probably be some years before the low-water flow of the river will be entirely used. The resacas form natural storage reservoirs capable of aiding in the irrigation problem to a certain extent when the supply of the river shall be entirely utilized. In connection with reservoirs, however, the sediment carried by the river deserves careful consideration. It has been estimated by those familiar with the region that 100 miles of resaca de los Palmas, 60 miles of resaca de la Guera, and 50 miles of resaca Fresno form part of the possibilities of storage. By constructing earth dams every 6 or 8 miles these resacas would form storage basins 250 feet wide and 7 feet deep. In addition, the Arroyo Colorado could be dammed to form several basins of an average depth of 25 feet and a maximum depth of 40 feet. This stream has a fall of 55 feet from its head to its mouth, a distance of 200 miles and an average width of 300 feet. The adjacent land could be irrigated partly by gravity both north and south of the stream. The water of this stream is sometimes salty, due to local rains.

*Hidalgo Company.*—In the records of the county office at Hidalgo is a notice of appropriation made in 1896 in the name of the Hidalgo and Cameron Irrigation Company, appropriating all the unappropriated waters of the river and all the underflow, stored and rain waters, all the lakes and resacas, and all other water, in or out of sight. The company had intended to irrigate 800,000 acres by a canal 30 feet wide on the bottom, 8 feet deep, and side slopes of 60°, to be 100 miles in length, and to deliver 1,370 cubic feet of water per second. The canal was to divert water by gravity from the Rio Grande and run to a point 6 miles below Brownsville. The project, however, fell through entirely.

*Hidalgo Canal Company.*—This company has a pumping plant on the river a short distance above Hidalgo, by means of which it irrigates 300 acres. The plant consists of two 50-horsepower boilers, furnishing steam at 80 pounds pressure to two 50-horsepower throttling engines, each driving a vertical centrifugal submerged pump. The



engines and boilers are in the open, and have no protection against the weather. The plant was installed in anticipation of the necessity of moving it, due to caving of the river bank. It is operated by two firemen and one engineer per twelve-hour shift. Wages in Mexican money are as follows:

	Per day.
2 firemen, at \$1.25 per day-----	\$2. 50
2 helpers, at \$0.75 per day-----	1. 50
1 engineer, at \$1.50 per day-----	1. 50
1 engineer, at \$5.50 per day-----	5. 50
Total-----	\$ 11. 00

Fuel consumption is between 8 and 10 cords of wood in twenty-four hours, at \$1 per cord. The pumps are stated to deliver a combined flow of 10,000 gallons per minute against a lift of 23 feet maximum. A rough observation, made at a point about 600 yards from the pumping station, indicated a flow of 11 cubic feet per second, or 5,000 gallons per minute. The main canal is 50 feet wide and very shallow, with small banks. Its grade is 3.5 feet for the first mile, and its total length is 4 miles. The company has also one lateral canal 50 feet wide and another 25 feet wide, each 1 mile long. Some of the lateral canals are 6 feet wide and run in the direction of greatest slope. The land is planted in alfalfa, irrigated by the check system, the checks being on 2-inch contours. The land has considerable slope, and is very much cut up by this method. The check system is not suitable for irrigation on steep slopes, and some other method should be used unless the land is leveled off. The bottoms of the ditches are lower than the irrigable land, and it is customary after the land has been irrigated to drain the water back into the ditches. The banks of the canals were poorly constructed, and are subject to considerable leakage. When starting to irrigate for alfalfa, the entire flow of the pump ran four days and three nights for 30 acres. The fourth time this land was irrigated, after the alfalfa had grown, only twenty hours' flow was required. Alfalfa is the principal crop, and the land yields 9 to 11 crops of 0.75 ton each per year. Land and water for irrigation are furnished to the tenants of the company for two-fifths of the crop.

*Closner plant.*—One of the most successful irrigation plants in this part of the country belongs to John Closner, who irrigates 500 acres situated 6 miles below Hidalgo on the banks of the Rio Grande. The pumping plant consists of a simple noncondensing engine 14 by 14 inches, which drives an 18-inch centrifugal pump delivering 6,000 gallons per minute. The steam pressure used is 60 pounds. The plant cost about \$3,000. One engineer and two firemen are required per shift of twelve hours for the operation of this plant. The fuel

<sup>a</sup> Equals \$5 in currency.

consumption is 14 cords of wood in twenty-four hours, costing \$300 per month of twenty-five days. One engineer receives \$50 per month, one \$30 per month, and the firemen \$12 per month each. Eight men, who receive \$12 per month, are required to take care of the irrigation water. The pump is operated ten months per year.

The principal crops are sugar cane and alfalfa. Alfalfa irrigation began in February and cane irrigation in March. The irrigation of alfalfa ceased the middle of November, while water was discontinued on the cane about the middle of September. Cane was irrigated by the furrow system and during the hot season it received an irrigation every twenty to twenty-five days. The furrows are about 300 feet long and 7 feet center to center. Alfalfa was irrigated by flooding by the check system, the size of the checks varying from one-fourth to 5 acres. According to the owner's figures the cost of irrigation was \$8 per acre. The present plant supplies sufficient water for the irrigation of 700 acres. The lift from the river is the same as at Hidalgo, namely, 23 feet at low-water stage. From the middle of May to the middle of June and from the middle of August to the middle of September are the usual periods for high water in the river, the lowest water occurring between the middle of December and the first of April. The river is liable to sudden rises from floods caused by rains or the melting of snow in the mountains. At a point near Brownsville last summer the rise in the river was 6 feet in as many hours.

A sugar mill which handles the cane grown on Mr. Closner's farm has recently been materially enlarged.

*Other plants.*—J. Box has an irrigated farm adjoining the Closner place. Seventy-five acres are at present under irrigation and it is the intention of the owner to irrigate 200 acres with his plant, which consists of a 12-inch centrifugal pump delivering 4,000 gallons of water per minute. One engineer and one fireman are required for the operation of the plant. The water is used principally for the irrigation of corn.

Twelve miles below Hidalgo is the plant of La Blanca Agricultural Company, which is similar to that of Mr. Closner and irrigates about the same area. One hundred and twenty acres of alfalfa are irrigated in forty-eight hours. The principal crops grown are alfalfa, corn, and truck. Florencio Ganz has a plant very similar to the Box plant. From the plants just mentioned down to the plant of the Brownsville Land and Irrigation Company no irrigation is practiced at present, though there is much prospective irrigation.

*Brownsville Land and Irrigation Company.*—This company, capitalized at \$300,000, has been a most important factor in the development of the lower Rio Grande Valley. Its pumping plant, situated on the river bank 6 miles above Brownsville, is the only one in this

vicinity which has made any attempt at permanent installation. In all the other plants the idea seems to prevail that the bank of the river is going to cave sooner or later and that it will hence be necessary to move the machinery. The Brownsville Land and Irrigation Company has built a brick wall along the river front for a distance of 150 feet to protect the bank. This wall, as well as the foundation of the power house, rests on a clay bottom. The suction pipes of the pumps project through the wall into the river. A clay foundation is apt to be treacherous, and it would have been preferable to have driven piling underneath the foundation of the wall and power house.

The pumping plant, which is built next to the river bank, consists of the following apparatus: One 200-horsepower water-tube boiler supplies steam at 100 pounds pressure to an 18 by 42 inch 225-horsepower Corliss simple condensing engine, which is belted to a 36-inch double-suction centrifugal pump, the suction pipe of which is 42 inches in diameter and the discharge end of which is square with an area equal to that of a 36-inch circle. The engine speed is 70 revolutions per minute and the pump speed 164 revolutions per minute. The engine is provided with a surface condenser giving only about 15-inch vacuum. Two 72-inch by 18-foot horizontal multitubular boilers of 125 horsepower each supply steam to two throttling, non-condensing, slide-valve engines of 125 horsepower each operating at a speed of 120 revolutions per minute. Each engine is belted to a 24-inch centrifugal pump run at 180 revolutions per minute. The pumps have a 26-inch suction and 24-inch discharge. The capacity of the plant under a 12-foot lift is 40,000 gallons per minute from the 36-inch pump and 20,000 gallons per minute from each of the 24-inch pumps at rated speeds, the normal speed, however, being 10 per cent less than the rated.

The labor required for operating the plant is as follows: Three engineers, each of whom works on an eight-hour shift, and 10 laborers and 4 firemen, each working a twelve-hour shift. The operation of the 36-inch pump requires 1 fireman at \$1.50 Mexican and 2 helpers at \$1 Mexican to fire the boiler, the remainder of the plant requiring 1 fireman and 3 helpers per shift. The fuel consumption for the 36-inch pump is 11 cords of wood per twenty-four hours, the pump speed being 10 per cent less than given above. The remainder of the plant consumes 13 cords of wood in twenty-four hours with the same reduction in pump speed.

The pumps discharge into a flume whose top lies directly over the discharge pipes. The lift of water as expressed by the figures of the company is the vertical distance between the bottom of the flume and the level of the water in the river. However, as the water runs at considerable depth in the flume, 2 feet should be added to the rated lift to obtain the actual distance, which in this case would allow for

only the depth of water in the flume and not for the velocity head of the discharge. The rated lift is between 12 feet 9 inches and minus 16 inches, or, in other words, practically between 14 feet 9 inches and 8 inches. During high water, however, it is necessary to run the pumps slowly, although the level of the water in the river is above the level of the bottom of the canal. Twenty-six cords of wood are consumed in twenty-four hours under a 10-foot rated lift. When the lift falls off the fuel consumption is 30 to 32 cords per day.

The main canal is 100 feet wide and very shallow and has a fall of 6 inches per mile. Excavations for the banks were largely made by borrow pits on the inside next to the banks, the canal having a section, as shown in figure 62. The deposit made by the river in the beds of the canals is partly clay and partly sand, but in most of the canals near Brownsville it is clay, which cracks open when dry and becomes almost as hard as soapstone.

About 25 miles of main canal have been constructed and water is furnished to 7,000 acres, planted mostly to rice. Two crops of rice per year are grown on part of the land, but the second is decidedly smaller than the first. The irrigation seasons for rice are from

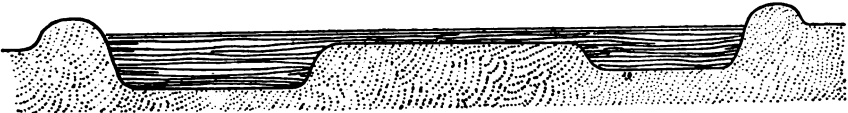

FIG. 62.—Section of Brownsville canal.

March 1 to November 1. The canal company figures that about 10 gallons of water per minute per acre are required during the season for rice irrigation. The first crop required one hundred days' irrigation and the second, sixty days. The land yields 4 to 17 sacks per acre, with an average of 10 sacks of 195 pounds each. The price realized for rice was between 2 and 3.4 cents per pound. For the irrigation of 6,000 acres of rice the yearly consumption of fuel was 2,250 cords of wood.

Rice land is irrigated by the check system of flooding, the areas of the checks varying up to 10 acres in extent. The bottoms of the ditches are in many places constructed considerably lower than the land itself in order to make the same ditch serve both for supplying water and to drain when it is necessary to draw the water off the land.

In addition to the rice, about 125 acres were planted in truck. The land for farming and water for irrigation of the same are furnished tenants for one-half the value of the crop, much of the land being farmed by renters. No measurement whatever was made of the water consumed by tenants.

Up to May 30, 1904, the 36-inch pump had operated forty-nine days and five hours, one 24-inch pump twenty-eight days and eight hours, and the other 24-inch pump nineteen days and two hours. The average corrected lift during this period was 11 feet 6 inches. During a test of the flow of the canal, made by the writer, the corrected lift was 12 feet 8 inches, and the quantity of water measured at a flume 1 mile from the power house was 64,800 gallons per minute. The conditions of operation of the machinery at the time were as follows:

36-inch pump, 63 revolutions per minute; engine, 147 revolutions per minute; pressure, 110 pounds; vacuum, 15 pounds.

24-inch pumps, 114 revolutions per minute; engine, 175 revolutions per minute; pressure, 90 pounds.

Mesquite, which is used for fuel, is rather green and when closely stacked weighs 3,700 pounds per cord. The price of same is \$1.60 to \$1.70 per cord. Brick construction is used very extensively in Brownsville, as it is cheaper than wood.

*The Brulaye plant.*—George Brulaye has an irrigation plant on the river 9 miles below Brownsville. His farm consists of 400 acres, of which 181 are at present under irrigation, 70 acres being in rice, 11 in corn, and 100 in cane. The lift from the river is about 15 feet at low water. The boilers supply steam to two engines, one of which drives a 15-inch and the other a 10-inch centrifugal pump. The 15-inch pump requires 6 cords of wood for a twelve hours' run, the 10-inch requiring 4 cords of wood for the same length of run. The pumping station is situated on the making bank of the river and the distance from the station to water has materially increased since the plant was first put in. At present the water is conveyed through a channel about 150 feet long to the suction pipe. At the time of the writer's visit the banks of the channel had caved in and all the pipes were filled with sand, and in consequence the plant was not in operation. A sugar mill was installed on the farm and the fuel consumption for both the power house and sugar mill was 700 cords per year. The engines and pumps are direct-connected units and were installed without adequate protection from the weather. The furrow system of irrigation is practiced for corn and cane.

On the Mexican side of the river there were several plants that are worthy of note.

*M. M. Mendiola plant.*—M. M. Mendiola, a well-known engineer in the employ of the Mexican Government, has an irrigation plant at Matamoras, across the river from Brownsville. A steam engine drives a centrifugal pump delivering 4,000 gallons per minute against a 22-foot lift. The fuel consumption is 8 cords of wood in twelve hours. The plant is sufficient for the irrigation of 300 acres of cane, though at present only 100 acres are irrigated. Sugar cane

requires six irrigations a year in dry weather. The plant is operated from 3 a. m. to 7 p. m. The irrigation season is from March to August, in which time the crop requires one hundred and fifty days' operation of the plant. Cotton is irrigated twice in dry years, once when planting and once when half grown. The pump station will irrigate 10 acres of land in twelve hours. All irrigation is done by flooding, the land being divided into checks and about half an acre in extent. It is flooded 8 inches deep, the owner preferring flooding to the furrow system, as it tends to kill the vermin. Corn in dry years receives two irrigations, one when it is planted in March and a second in May.

*The Fernandes plant.*—Near Matamoras is an irrigation ranch belonging to J. H. Fernandes, consisting of 600 acres, planted to rice. The pump capacity is 14,000 to 20,000 gallons per minute, but only one-third of this capacity is used for the present acreage. A 24-inch pump furnishes the water supply to the land, and it is the intention of the owner to irrigate 2,500 acres. A 15-inch centrifugal drainage pump is used in connection with this work. The water pumped by the latter is used for the irrigation of pasture.

*Sauto Company.*—The Sauto Company applied to the Mexican Government for an appropriation of 20 cubic meters of water per second, to be used for the irrigation of land near Matamoras. The application was refused, however, since the quantity asked for was more than one-half the minimum rate of flow of the river. The Government, however, said it would grant them 183 second-feet, the same being one-third of half of the minimum flow of the river, or a flow of 1,100 cubic feet per second. The company owned 100 square leagues of land, but it is thought possible that they may irrigate 10 square leagues with the flow which they would be allowed to appropriate. This would be a duty of over 300 acres to the second-foot, which is decidedly large considering the nature of the country. Up to July, 1904, the Sauto Company had taken no action on the offer of the Government.

On the San Diego River, 25 miles from Del Rio on the Mexican side, an irrigation company proposes to irrigate 60,000 acres of land from the river by a gravity system, with the aid of storage. The land to be irrigated lies in two tracts, the lower of which is 60 feet above the Rio Grande. There is a fall of 278 feet between the site of the proposed storage reservoir and the lower irrigable land. It is proposed to utilize the water power in two falls of 40 and 50 meters, respectively, for pumping water from the Rio Grande to assist in irrigation work. A large canal with a capacity of 4 cubic meters per second is intended for the irrigation of 30,000 acres, and a canal with a quarter of this capacity will be utilized for power purposes.

The Rio Grande was formerly navigable some distance above Hidalgo, but in recent years the sediment has deposited so rapidly that at present no attempt at navigation is made. The river is still classed as a navigable stream by the Government, and it may be considered an open question what effect the diversion of water would have on its legal aspect. Among the principal tributaries on the Mexican side may be mentioned the San Juan River, which empties into the Rio Grande 108 miles above Brownsville, and the Salavo River. The water of the former is of a good quality; the Salavo River is decidedly salty and alkaline.

#### NUECES, FRIO, AND LEONA RIVERS.

Beginning a short distance north of the Southern Pacific Railroad in Uvalde County the ground rises gradually to the mountains in the northern part of the county. Several rivers and creeks have their headwaters in the mountains, among which may be mentioned the Nueces, Leona, Frio, and Dry Frio rivers, all of which finally empty into the Nueces. The beds of the rivers in the mountains are filled with loose rock and gravel, through which the water percolates when the rivers are low. The river beds themselves are of rock, and where the gravel layer is thin surface flow appears. By the time the rivers reach the plains the flow has largely disappeared, except in times of wet weather. South of Uvalde, however, the Leona River always carries sufficient water to serve for considerable irrigation. On the visit of the writer to this district in July, 1904, the rivers were at an exceptionally low stage. In the mountains the flow from the Nueces and Frio rivers was utilized for irrigation, and the supply was sufficient for the present needs of the country. The river valleys in the mountains, while not wide, still have a considerable amount of land capable of being irrigated to good advantage. In general, however, it may be said that large tracts of irrigable land lies toward the center and south of Uvalde County, and to obtain irrigation water for this land would necessitate the construction of storage reservoirs. There are a few sites on these rivers where, from preliminary observations, it would seem that storage reservoirs could be built to advantage. There has been some talk of their construction, but no actual steps have been taken in this direction.

#### NUECES RIVER.

*Fern Lake Ranch Company.*—A few miles north of the town of Montell is a 190-acre tract owned by this company and irrigated by a ditch from the river. A dam 2.5 feet high and 4 feet base, built of gravel and willows, serves to raise the level of the water sufficiently to irrigate the land by gravity. Like other dams of this nature, it leaks

considerably, but as there is sufficient water in the river this is a matter of no consequence. The ditch is 3 feet wide on the bottom, 5 feet on top, and 3 feet deep. Water runs about 30 inches deep. The ditch is said to carry 3,000 gallons per minute. At the time of the writer's visit it was not full and was carrying, by measurement, about one-half this quantity of water. One hundred and twenty acres are planted in Johnson grass, irrigated every fifteen days; 35 acres in cotton, irrigated twice a season; 35 acres in corn, irrigated twice a season. The yield of corn was 30 bushels per acre.

The ditch full will irrigate all the corn and cotton land in fifteen days of twelve hours each, and Johnson grass in ten days. The latter is irrigated by the tablet system, the tablets being 40 to 60 feet by 200 to 300 yards long. One man can look out for the irrigation of Johnson grass at the above rate and two men for the irrigation of corn and cotton. The yield of Johnson grass is 1 ton per cutting and 4 cuttings per year.

*W. M. Jones ranch.*—A short distance below Montell, W. M. Jones irrigates 50 acres with water pumped from the river. A 6-horse-power gasoline engine drives a No. 3 centrifugal pump delivering 350 gallons per minute against a 27-foot lift. The engine uses 9 gallons of gasoline in ten hours, the cost of same being 12.5 to 18 cents per gallon.

Twenty acres were planted in cotton, which up to the end of July had received one irrigation; 30 acres in corn and sorghum, which received two irrigations per crop. A ten-hour run of the pump furnished sufficient water to irrigate 3 acres. The tablet system of irrigation is used, the tablets being 50 to 80 feet wide by 400 yards long. One man can irrigate 1.5 acres in a day with one-half the flow of the pump. Corn yielded 30 bushels per acre.

*Baylor ranch.*—A short distance below the Jones ranch Mr. Baylor irrigates 25 acres with water from Montell Creek, which, however, runs dry part of the time. A ditch about 18 inches wide runs 6 inches deep, delivering a flow of 800 gallons per minute. Four acres planted in corn were irrigated every fifteen days; 18 acres in Johnson grass were irrigated every fifteen days; 3 acres were planted in cane.

A rock-and-clay dam was used for diverting the water, which flowed into an earth tank 2 feet deep, 350 by 95 feet. The flow of the ditch will fill this tank in ten hours. The tank full will irrigate 4 acres in six hours. Johnson grass was irrigated by the tablet system, the tablets being 30 feet wide and 240 yards long. The yield of corn was 30 bushels per acre.

A few miles below this ranch an attempt was made a few years ago to dam the Nueces River to divert water into a ditch which was to irrigate a large area near the base of the mountains. At the dam



site selected the river had filled up to a depth of some 17 feet with rock and gravel, and to cut off the underflow from the same sheet piling was driven through the rocks. The piling was composed of three pieces of 3 by 12 held together in such a way as to form a tongue-and-groove boarding, the middle piece being offset. This attempted dam, however, was a dismal failure, as the sheet piling drove anything but straight through the bowlders and utterly failed to intercept the flow of water. Figure 63 shows a section of the river at the point of the attempted dam.

Still another difficulty encountered was in the construction of a ditch for diverting the water. The ground through which the ditch ran was gravelly and acted like a sieve. Only a short section of the ditch was constructed and that has now been abandoned.

At present there is a proposition to divert the river water at a point a short distance above this dam site, where the bed rock of the river comes to the surface. The projected plan involves the construction of a low dam at this point, whence the water will be carried by

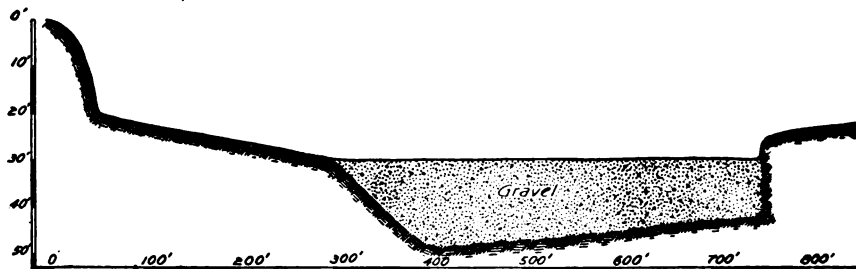

FIG. 63.—Section of Nueces River bed.

a pipe submerged in the river channel to a point about a mile distant, where the head of the ditch will be located. One idea of this plan is to avoid encountering the gravelly strata through which the old ditch ran. The water would then be conveyed by a ditch some 20 miles long to an earth reservoir built by damming some of the draws in the foothills. If this were carried out an immense quantity of land would be subject to irrigation. The main point about such an undertaking is the building of a reservoir of suitable size. The estimated storage capacity of the proposed one was 124,000,000 cubic feet. Allowing 18 acre-inches storage capacity for the irrigation of 1 acre would make this reservoir capable of irrigating 2,000 acres. A continuous supply from the river would of course increase to a considerable extent the acreage which would be subject to irrigation.

For this proposed reservoir the embankment is to be 5 feet higher than the level of high water, 14 feet wide on top, built with side slopes of 3 to 1. The maximum height of the dam will be 42 feet and the length 1,700 feet. The cubic yards of earth in the dam would be 310,000.

A measurement of the river at the proposed dam site, made in the latter part of July, 1904, showed a flow of 35 cubic feet per second. At the point where this measurement was made there was a considerable bed of gravel, which would add materially to the actual flow, which, as an approximation, was a total of perhaps 50 cubic feet per second.

*Dodson farm.*—A short distance below the site of the attempted dam is the farm of J. J. Dodson, who irrigates 144 acres with water pumped from the river. Two 40-horsepower boilers supply steam to a 65-horsepower throttling engine driving a No. 6 centrifugal pump delivering 1,000 gallons per minute against a head of 39 feet. The boilers consume 2 cords of mesquite in twelve hours' run. The mesquite grows on the land of the owner and the cost of cutting and hauling is \$1 per cord.

Three acres were planted in alfalfa which received two irrigations for each cutting. This was not a very successful crop. One hundred and fifteen acres were planted in cotton, which in 1904 received one irrigation. When the weather is dry the owner figures that two or three irrigations per season would be necessary. Two acres were planted in truck, 4 in sorghum, and 20 in corn. The latter received one irrigation, but in dry years would require two. The yield of corn was 30 bushels per acre. Part of the time it was necessary to run the plant day and night.

The tablet system was used for alfalfa and the furrow system for other crops. The flow of the pump would irrigate 8 acres in twelve hours by the furrow system and 3 acres in the same time by the tablet system. Alfalfa was laid off in tablets 25 by 300 feet. The rows in the furrow system were 600 feet long on 4-foot centers, the flow of the pump being divided between 2 to 3 rows. The time required to run through the rows was twenty to thirty minutes.

#### FRIO RIVER.

In this section of the country the term "head of water" is used as a kind of unit of measurement, meaning the amount of water that one man can handle to advantage in irrigation, and may be considered to be from about 1,000 to 1,500 gallons per minute, though it is naturally a widely varying quantity.

*Grigsby & Horton ditch.*—Grigsby & Horton own 120 acres of land near Lakey, which is irrigated by water diverted from the Frio through a ditch 3 feet wide on the bottom, 5 to 6 feet wide on top, and 2 feet deep. The ditch, which was constructed in 1897, is 2 miles long and has a grade of 2 inches in 300 feet. It is said to carry two "heads of water," and irrigates 60 acres of corn and 60 acres of cotton, each of which received two irrigations in 1904. The flow of the ditch is sufficient to irrigate 10 acres in twenty-four hours. At

present water is used mainly in the daytime. In very dry weather the ground should be irrigated every fifteen days. The soil is black and waxy, 2 feet deep, with clay subsoil. Corn will yield 30 to 35 bushels per acre and cotton three-fourths to 1 bale per acre. The owner figures that by irrigating day and night the amount of land irrigated could be doubled. Water is diverted from the creek by a log, brush, and gravel dam, which raises the water level 1 foot. The furrow system of irrigation is used, the furrows being 150 to 300 feet long. One head of water is divided between 8 to 10 rows, and twenty minutes' flow is required to irrigate furrows 300 feet long. The rows are 3.5-foot centers.

*Smith, Patterson & Watkins ditch.*—Near the town of Rio Frio a ditch, constructed by Smith, Patterson & Watkins in 1867, diverts water from the Frio River for the irrigation of 850 acres of land. The ditch is 5 feet wide at the bottom and 3 feet deep, set on a grade of one-sixteenth inch per rod, and delivers between 3,000 and 4,000 gallons per minute. Five hundred acres are planted in cotton and irrigated every twenty-one days, the yield being 1 bale to the acre; 300 acres are planted in corn, irrigated every twenty-one days, the yield being 45 bushels per acre; 50 acres are planted in oats and wheat, irrigated every twenty-one days. The yield of oats is 15 to 30 bushels and of wheat 20 bushels per acre. A small amount of truck is also grown. The ditch is 5 feet wide on the bottom, 3 feet deep, and 3.5 miles long, and its capacity is said to be 3.5 "heads," which would mean that a head in this case is equivalent to a flow of 1,000 gallons per minute. One head will irrigate 10 acres in twenty-four hours. Land, with water-right, rents for one-third of the crop, and labor costs \$12 to \$15 per month and board.

Ditch water is divided in proportion to the land to be irrigated, each field receiving water every three weeks, the water running continuously in the ditch. When the river is at its lowest stage this ditch consumes all the visible supply, though there is considerable more water under the gravel bed. The full supply of the ditch is required for irrigation. Land is watered by the tablet system, the tablets being 40 to 48 feet wide and the length varying up to 1,200 feet. The water is run 40 to 50 feet down the tablets from each opening made in the supply ditch.

Where the Frio River emerges from the mountains the valley narrows to about 600 feet and on either side for a height of about 60 feet the walls are solid rock, forming apparently a good site for a dam. Some years ago there was a project to build a dam at this point and convey the water by ditch to the plains near Uvalde, but no work was ever actually undertaken in this direction. The area of the watershed of the river up to the dam site has been estimated at 750 square miles, and the run-off in the mountains is undoubtedly high.

Several unsuccessful attempts have been made to find artesian water on the line of the Galveston, Harrisburg and San Antonio Railway from Uvalde to Sabinal. In a well 1,822 feet deep at Sabinal water rises to within 80 feet of the surface. At a point 18 miles to the west of Uvalde a well 1,500 feet deep was sunk, in which the water was 300 feet from the surface. Although the water disappears in dry weather in many of the rivers as they emerge from the hills, still it follows along under the river channel in many places, and the indications are that large surface wells can be obtained in some localities.

The city waterworks of Uvalde has a well from which the supply for the city is derived which is 100 feet deep. At a depth of 40 feet there is a stratum of gravel 3 to 4 feet thick, with clay below it. This was originally a dug well 20 feet square and 40 feet deep, but in 1897 the water gave out, whereupon three 6-inch open-bottom wells were drilled in the bottom of the old well 60 feet deeper. The water at present rises to 33 feet from the surface and is scarcely lowered by a pump with a capacity of 1,000 gallons per minute. A direct-acting steam pump delivers the water against a pressure of 45 pounds, with a suction lift of 6 feet. Two and one-half cords of oak or elm are consumed in eight hours, with a delivery of 800 gallons per minute.

Ike West has dug a well 30 feet deep and 5 feet square 5 miles from Uvalde. Water stands 4 feet deep in the well, which is about 400 yards from the Leona River. The water-bearing stratum consists of bowlders. The surface soil is a light-red sandy loam 6 feet deep, underlain by a clay subsoil. A 20-horsepower engine drives a vertical centrifugal pump for lifting water from the well.

Considerable irrigation is carried on below Uvalde with water taken from the Leona River. The river is dammed in several places by means of crib dams, which raise the water to a sufficient height to irrigate the land by gravity and at the same time serve as storage basins of small capacity. Three miles south of Uvalde is a rock-filled crib dam belonging to Mr. Patterson, resting on a rock bottom. The dam is 9 feet wide at the base, with the timbers notched and bolted together, and sets into the banks 20 feet. It is faced with an apron of 2-inch plank, which is covered with dirt to aid in making it water-tight. The dam is 140 feet long with the addition of the two 20-foot wings, and is 6½ feet high. The cost of construction was \$1,250, the work being let by contract. The timbers built for forming the crib work are about 14 inches in diameter on the small end and made of oak. The dam has lasted two years without accident, but so far has not passed through any severe flood. It backs the water up 2 miles in the river, which has an average width of 120 feet and a depth of 4 feet. The water can be drawn down 3½ feet. The ditch

which heads near the dam is 6 feet wide on the bottom, 9 feet on top, and 3 feet deep, with a slope of 2 feet to the mile. It is owned by a company, the stock being divided into six shares, of which Mr. Patterson owns  $3\frac{1}{2}$  shares. Eight hundred acres are now under irrigation from this ditch, which delivers a flow of 4,000 gallons per minute. Irrigation is carried on day and night; one share in the ditch entitled the holder to twenty-fours' flow of the ditch every six days. The irrigators take what water they please and regulate the same by a gate at the head of the ditch, no measurement of water being taken. A ditch man is employed whose duty it is to keep the ditch clean and in repair. Mr. Patterson's land, which is situated at the end of the ditch, 9 miles from Uvalde, in addition to the ditch supply receives water also from a pumping station on the river, adjoining his farm. A 50-horsepower boiler supplies steam to a duplex steam pump delivering 1,200 gallons per minute against a lift of 22 feet. The plant consumes  $1\frac{1}{2}$  cords of live oak or elm in twenty-four hours' operation. The cost of the wood is 60 cents a cord delivered at the pump. As the wood comes off the land of the owner, only the cost of cutting and hauling is included in these figures. For the past two years the pump has not been operated, as the ditch supplied sufficient water. However, in time of low water the pump is an additional security against an insufficient supply, the river between the dam and the pump being fed by a number of springs. Near the pumping station is a dam of natural rock which forms a reservoir 1 mile long and 75 feet wide, 15 feet deep in places. Mr. Patterson irrigates 500 acres, but thinks he would be able to irrigate twice this acreage with his present water supply. Two hundred acres are planted in cotton, irrigated four to five times each season, and 150 acres of Johnson grass, irrigated six to eight times; 70 acres of corn, irrigated four times. The Johnson grass is irrigated twice per cutting, and is usually cut four times a year. The cotton land formerly produced 1 bale per acre, but the ravages of the boll weevil have materially cut down this yield. Johnson grass yields 1 ton per acre per cutting and the corn 30 bushels. With the full flow of the ditch—4,000 gallons per minute—40 acres of land can be irrigated in twenty-four hours.

Irrigation throughout this district is carried on by the tablet system. The tablets are 36 feet wide and 300 feet long, and are mainly irrigated from the small ditches running lengthwise of the tablets, though occasionally a head ditch is used for this purpose. Canvas dams are used in the head ditches for stopping the flow of water. One man handles one-quarter of the full flow of the ditch, turning the same into one tablet. The irrigation season lasts practically all the year. T. E. Taylor irrigates 150 acres of corn and cotton from the Patterson ditch. J. L. Tyner irrigates 150 acres of corn, cotton,

and Johnson grass from the same source. Johnson grass, which formerly sold for \$15 per ton, now sells for \$10 per ton in Uvalde.

Below the Patterson place the Leona River is dammed to supply water to a ditch owned by A. A. Kelley, B. F. Wilson, and L. R. Norseworthy. Five hundred and fifteen acres are at present in cultivation from this ditch. Three hundred acres are owned by Mr. Kelley, who is entitled to six-twelfths of the flow; 175 acres by Mr. Wilson, who is entitled to five-twelfths, and 40 acres by Mr. Norseworthy, who has one-twelfth of the flow. The ditch is said to deliver four heads of water, or about 4,000 gallons per minute. One head will irrigate 1 acre per hour. Land in this vicinity sells for \$50 per acre, with water rights included, and rents for one-third of the crop. It is to be noted that the water right goes with the land.

The Kelley ditch is 6 feet wide on the bottom, 9 feet wide on top, and 3 feet deep, and the water runs in the same to a depth of about 2 feet. The slope of the ditch is 18 inches per mile and the length is 2 miles to the nearest farm which it supplies, and  $2\frac{1}{2}$  miles farther to the end of the ditch. It was built in 1870 and has been somewhat enlarged since then. The full flow of the ditch is said to irrigate 4 acres per hour.

J. C. Priddy irrigates 105 acres by the tablet system, 40 acres in corn, 60 in cotton, and 5 in cane.

*The Lewis plant.*—G. W. Lewis irrigates 220 acres of land lying a short distance south of the end of the Kelley ditch. Irrigation water is pumped from the Leona River, and the supply pumped is just sufficient to irrigate the land. A 45-horsepower throttling engine drives a 10-inch centrifugal pump running 310 revolutions per minute, delivering 2,400 gallons per minute against a lift of 23 feet. The fuel consumed is 5 cords of wood for twenty-four hours' run, in which time 10 acres of land can be irrigated. One hundred and seventy acres are planted in cotton, irrigated about every three weeks; 50 acres in corn, irrigated every three weeks. The tablet system of irrigation is used, two men handling the supply of water from the pump. This year the probable yield will be at least one-half bale of cotton to the acre. The boll weevil has caused considerable trouble in this vicinity. The crops received 5 irrigations in the year.

The main ditch is 6 feet wide on top and 18 inches deep and V-shaped. Some of the tablet ditches are as much as 200 feet apart, and one irrigator will turn one-half the supply of the pump into 20 rows, which are about 50 feet long.

*Batesville.*—The Comanche Ditch and Irrigation Company, which is about thirty years old, diverts water from the Leona River near Batesville and irrigates about 500 acres of corn, cotton, oats, Johnson grass, fruit, and truck. The ditch is about 8 feet wide on top, 3 feet deep, and water runs 2 to 2.5 feet deep in the same. It is said

to carry two heads of water. One head per hour per acre is allowed for irrigation, the irrigation period recurring every ten days. A dam composed of brush, dirt, and gravel 10 feet high forms a reservoir in the river bed 1.5 miles long, 30 feet wide, and 4 feet deep. It washes considerably with every freshet. When the supply of water falls off, one head of water is used instead of two and the time of use is correspondingly cut down. When the pumps farther up the river are operating there is sometimes not sufficient water for one head. The main idea of the dam was not so much for storage as to raise the water to a sufficient level to supply the ditch. Altogether about 640 acres owned by the company are subject to irrigation. The tablet and bed systems are used, the tablets being 45 to 60 feet wide and the beds 20 to 40 feet wide, with a length of 150 to 200 feet. One head of water will irrigate a bed in fifteen minutes.

In this vicinity there are indications of good surface wells. At a depth of 30 feet is a water-bearing gravel stratum 8 feet in thickness underlaid with sand and gravel strata. The water stands 35 to 45 feet below the surface of the ground.

Artesian water is found in the southwest part of Zavalla County, being a continuation of the artesian belt near Carrizo Springs. Ed English and B. H. Eskins have each two artesian wells, and James Odin has one in that vicinity used for irrigation, and there are also a few other artesian wells used for stock.

*Artesia.*—Near Artesia artesian water in small quantities has been discovered and there are at present in this vicinity seven open-bottom wells, 5 $\frac{3}{8}$ -inch casing, delivering a flow of 12 to 18 gallons per minute each. These wells are 500 feet deep, and are located within 1.5 miles of the railroad station. The artesian water-bearing stratum is fine sand. The wells were put down by horsepower machines, and cost \$1 per foot to complete. The total area irrigated is 75 acres, the main crops being truck and onions. Four acres of onion land gave a yield of 2.5 cars. In connection with irrigation there are two storage reservoirs 8 feet deep and 0.5 and 0.75 acre, respectively, in area.

*Cotulla.*—The Nueces River runs near the town of Cotulla and furnishes water for several irrigation plants in that vicinity. The surrounding country is very rolling, though occasional places are to be found where the land is sufficiently level for farming to good advantage. However, much of the hilly land is also farmed.

The supply of Nueces River is variable. In times of high water the discharge is very great, while at low water it practically disappears. The indications are, however, that there is a considerable sub-surface flow when water has disappeared entirely from the surface channel. Owing to the lay of the land pumping is necessary in order to irrigate. Some of the pump stations have been installed so

low down that they are entirely submerged during high water. This is a practice which can hardly be looked upon with favor.

*Hargus plant.*—This is 3 miles above Cotulla and is just being installed. It has a 60-horsepower boiler, with a 40-horsepower throttling engine, which is belted to a No. 6 centrifugal pump, having a 10-inch suction and 10½-inch discharge pipe of a total length of 660 feet. The lift of this plant is 35 feet and the flow of the pump is supposed to be 2,500 gallons per minute. In all probability the economic flow will not be more than one-half this, however. One hundred and thirty acres to be planted in onions and alfalfa will be irrigated. It is the intention of the owner to dam the river in order to provide storage for a small amount of water. The river has a fall of 8 inches per mile. In general the distances by river are about twice as long as by land.

*Caley plant.*—H. Caley irrigates 40 acres situated near the Hargus plant. A 30-horsepower boiler supplies steam to a 60-horsepower automatic engine driving a No. 3 centrifugal pump, delivering water to the field through a 3.5-inch pipe, the farthest point of delivery being 1,500 feet from the pump station. The height of this point of delivery above the river is about 40 feet. There are three outlets for the water in the pipe line. The flow of water is said to be 300 to 500 gallons per minute, depending upon which outlet is open. The fuel used is mesquite, 0.75 cord being consumed in twelve hours.

The river is dammed near the farm by a structure 3 feet high and 30 feet long, composed of loose rock on the lower side, while on the upper side is a wooden apron covered with dirt. Floods have caused no trouble with the dam, the water passing over the same without damage. It backs the water up 2 miles in the river, forming a reservoir with an average width of 35 feet when water is near the top of the dam. Before the dam was put in there was a shortage of water, but since the installation of the same no trouble has been experienced on this account.

Thirteen acres were planted in onions and the remainder in cantaloupes, tomatoes, corn, and truck. White Bermuda and Crystal Wax onions were sown and were spaced 3 to 4 inches apart in rows 12 inches apart. The crop was harvested April 15 and sold for 1.5 cents per pound, yielding \$3,349.

The land was irrigated by the furrow system every 15 days and it required twelve hours pumping to irrigate 2 to 4 acres. The furrows were 60 feet long. The season for irrigating tomatoes is October 1 to January.

With one irrigation 1.25 acres of corn yielded 80 bushels. Cotton land yielded without irrigation 1 bale per acre.

The soil is a black chocolate sandy loam 3 feet deep, with clay subsoil. No fertilizer was used.



One to two men are required to handle the water. The owner cuts his fuel and estimates it to cost 50 cents per cord. With a larger pipe he figures that he could irrigate 65 acres. Usually the plant is run in the day time only, but during the past season it ran six nights.

*Fuller plant.*—Near the Caley place is that of Mr. Fuller, comprising 15 acres. The pumping plant which draws water from the same storage consists of a 15-horsepower boiler, which supplies steam at 75 pounds pressure to a No. 7 pulsometer, lifting water 35 feet and delivering 400 gallons per minute through 460 feet of 4.75-inch pipe. The fuel consumed is 0.75 to 1 cord in twelve hours' run. The owner of the plant says he could irrigate with the flow of the pump 30 acres without night run. He irrigated 4 acres of truck with six hours' run of the plant, using the furrow system, but intends to change to the bed system. Land is irrigated every fifteen days, receiving six to eight irrigations per season. The yield of 1 acre of tomatoes brought \$300.

A short distance from these plants are two farms belonging to Mr. Goldtrap and Mr. Gates, respectively, which obtain water by pumping from a small lake.

*Goldtrap farm.*—This comprises 101 acres planted in corn, cane, cotton, and tomatoes and irrigated by the furrow system. The pumping plant consists of a 35-horsepower boiler and a 35-horsepower throttle engine belted to a centrifugal pump delivering a rated flow of 800 gallons per minute through 1,000 feet of 6-inch pipe against a lift of 40 feet. The fuel consumption is 0.5 to 0.75 cord of wood per day. To irrigate the entire area would require pumping six days of twelve hours each per week, and requires the services of two men for irrigating and one man for operating the pump station.

The furrow system of irrigation is used, the furrows being 60 to 150 feet long. Cotton is irrigated every sixteen days, with about four irrigations per season; corn every twenty days, with about three irrigations per crop. Cane received one irrigation per crop; tomatoes four irrigations per crop. Two crops of corn, cane, and tomatoes per year are gathered. Corn was planted in January and August; cane in the early spring and in June; tomatoes in January and August.

The size of the lake when full has been estimated at 0.5 mile long, 50 yards wide, and 8 feet deep. The lake derives its supply from the river which flows into the lake when the river rises 4 feet. Evaporation and seepage from the lake is about one-eighth inch per day, and about the same amount of water is taken out by the pumps of the two plants drawing from the lake.

The flow of the pump was turned into four to six rows. While irrigating the pump averaged four days' run per week.

A small part of the land was planted to onions, which were spaced 4 inches apart in rows 12 inches apart. They yielded 15,000 pounds

per acre, and the crop was all harvested by April 25. The onions were irrigated every ten days.

The soil is deep and is composed of a light waxy loam.

*Gates farm.*—Adjoining the Goldtrap farm is one of 100 acres belonging to Mr. Gates. A 30-horsepower boiler supplies steam to a 30-horsepower engine belted to a No. 5 centrifugal pump, delivering a flow of 850 gallons per minute from the lake against a vertical lift of 42.5 feet through 500 feet of 8-inch pipe. The fuel consumed is 0.75 cord of wood in ten hours. The pump is operated about one-quarter of the time during the irrigation season.

Eighty-three acres were planted to cotton, requiring 3 to 4 irrigations per season, from March 1 to August 1. The furrow system was used, the furrows being 50 to 100 yards long and 4 feet apart. The flow is turned into 3 to 7 furrows at the same time and it takes five minutes for the water to run through the same. The yield was 1 bale per acre. The boll weevil is causing considerable trouble in this section now.

Five acres of cane, 2 acres of corn, and 10 acres of tomatoes were also irrigated, the latter requiring irrigation every two weeks during dry weather.

The level of the lake does not vary much more than 1 foot and this variation may be expected within four months' time.

*Kech plant.*—Southeast of Cotulla, a short distance from the town, is the 25-acre farm of E. A. Kech. The pumping plant consists of a 15-horsepower boiler and a duplex pump delivering 250 to 300 gallons per minute against a head of 35 feet through 2,000 feet of 4-inch pipe. The plant consumed 0.75 cord mesquite in twelve hours. The pump draws its supply from a small reservoir in the river formed by a rock and dirt dam which in high water cuts out considerably.

Last year 15 acres were planted in onions and 10 acres in melons and corn. The latter were not irrigated. The onion land, after the removal of the crop, was planted in cowpeas and tomatoes, no irrigation being required for the cowpeas up to July. Onions were irrigated every twelve days by the furrow system. The furrows were 30 to 40 feet long, and the flow of the pump was turned into three or four furrows at a time. One man irrigated 3 acres of onions a day. The onions were planted 3 inches apart in 12-inch rows. The yield was 20,000 to 30,000 pounds per acre. The crop was harvested in May.

In irrigating for tomatoes the entire flow was turned down one furrow, making the amount considerably too great for the furrow and difficult to control.

*Seefeld plant.*—Adjoining the Kech place is the farm of R. H. Seefeld. A new plant is being installed to pump from the river and

consists of a 30-horsepower boiler and 25-horsepower throttling engine driving a No. 5 centrifugal pump delivering a rated flow of 1,000 gallons per minute against a head of 36 feet. The pump will deliver water into a galvanized flume lined with 42-inch sheets bent half-round, this form of construction being used since it is cheaper than pipe and avoids the loss in head which occurs in pumping through a small pipe. The flume has a slope of 18 inches in 625 feet. Last year a 15-horsepower boiler was used to supply steam to a direct-acting pump delivering 300 gallons per minute against a head of 36 feet and forcing the water through 700 feet of 4.25-inch pipe. One cord of wood was consumed in twelve hours' operation of the plant during which time 3.5 acres of onions could be irrigated. Wood costs \$1.50 per cord. The wages of a man for operation of plant were 55 cents per day. The cost of operating plant was \$2.25 per day.

Onions were spaced 3.5 inches apart in 12-inch rows and irrigated by the furrow system, the furrows being 30 to 50 feet long. The yield was 20,000 pounds per acre. No fertilizer except cowpeas was employed.

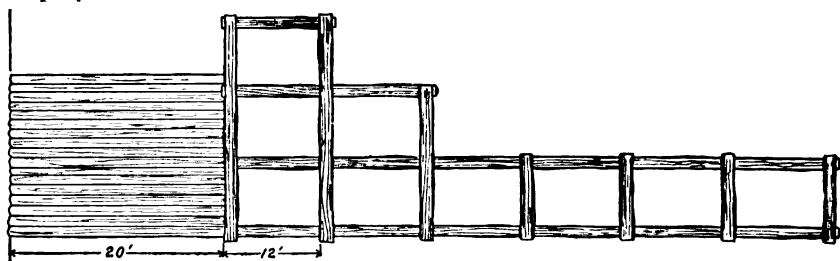
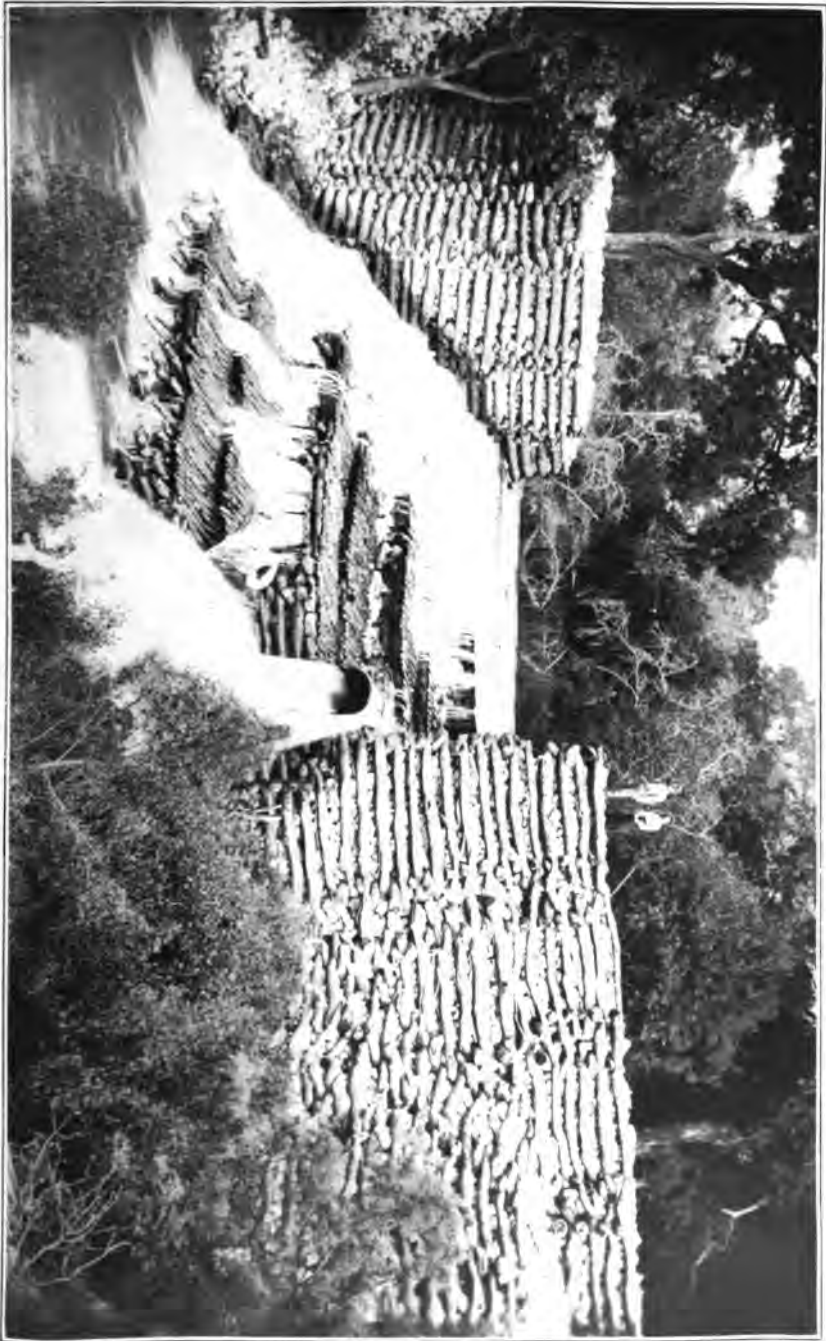

FIG. 64.—Plan of Taylor dam, Nueces River, Texas.

*Taylor plant.*—About 30 miles from Cotulla, on the road to Carrizo Springs, is an irrigation plant engineered by J. S. Taylor. The farm is situated on the northeast bank of the Nueces River, which is dammed by a rock-filled timber crib structure (see Pl. VII and fig. 64) 500 feet long over all and 110 feet wide at the base. The maximum height at the spillway is 32 feet, the wings being built up 10 feet higher than the rest of the structure. The dam rests on a clay foundation and is built up with timber cribs 12 feet square composed of rough logs spiked together with  $\frac{3}{8}$ -inch square spikes. The spillway, which is in the center of the dam, is 40 feet wide, and is built of rough logs spiked in place and held down also by rock, constructed in such a manner as to let the water down in a series of drops of 2 to 8 feet each, in a horizontal distance of 40 feet. The dam is back-filled with rock covered with dirt with a crest of 15 feet and a slope of 1 in 2. Six feet below the spillway is the top of the wastepipe, 3 feet in diameter, provided with a gate valve. The dam backs the water 10 miles up the river with a storage area estimated by Mr.



TAYLOR DAM, NUECES RIVER, TEXAS.



Taylor at 15 miles long, average width of 175 feet, and average depth of 15 feet, 5 miles of a branch of the river being included in this estimate.

The plant serves at present for the irrigation of 175 acres, of which 100 can be irrigated by gravity and 75 acres by pumping. The gravity canal is 9 feet wide on top and 3 feet deep near the head, and 8 feet wide on top, 3 feet on the bottom, and 1.5 feet deep near the end of the canal, which is 1.5 miles long. The grade is 1.5 feet per mile. A heavy cut was made where the canal heads near the dam and water can be drawn off by gravity not more than 2.5 feet below the top of the dam; therefore the gravity system can be used for the most part only when there is a flow in the river, and can make little use of the stored water. The canal is provided with a wooden head gate 10 feet wide and 6 feet high.

A No. 5 centrifugal pump driven by an 18-horsepower engine is used to lift water 12 feet above the level of the top of the spillway and delivers a flow of 1,200 gallons per minute. The flow of the pump was used to irrigate onions, corn, and cane. The furrow system was employed. The furrows for onions were 18 inches apart and 100 feet long. Onions were spaced 4 inches apart in 18-inch rows. The land was plowed and cultivated by the use of horses, the spacing being sufficiently wide to permit of this. The land was irrigated every eight to ten days and required four hours' run of the pump to irrigate an acre. In irrigating, the flow of the pump was turned into 20 rows at a time.

Onions were harvested May 1 and the yield was 11,000 to 16,000 pounds per acre. No fertilizer was used.

The dam as originally constructed was built with insufficient wings, which resulted in its washing out around the ends. The cost of the present dam and canal was \$35,000.

Irrigable land in the vicinity which originally sold for \$1.50 per acre now brings \$10 to \$15 per acre.

At the time of the writer's visit, about the middle of July, 1904, no water was flowing over the spillway of the dam.

#### LAKES NEAR CARRIZO SPRINGS.

Near Carrizo Springs is a chain of seven lakes which receive their water partially from the drainage of the surrounding land and partially from the river when water is sufficiently high. In fact, they afford additional channels through which the river water may flow in times of flood. The drainage area from which it is estimated that these lakes are fed is 100 by 25 miles. The overflow from the lakes runs into the river farther down. The following estimates have been

made by those familiar with the country as to the probable size of these lakes:

*Capacity of lakes near Carrizo Springs.*

Name of lake.	Length.	Width.	Depth.	Capacity.	Mean.
	<i>Miles.</i>	<i>Feet.</i>	<i>Feet.</i>	<i>Acre-feet.</i>	<i>Acre-feet.</i>
Rocky.....	1	180	11	259	259
	7	300	15	3,820	
Caymanche.....	6.5	225	11	1,950	2,650
	4	300	15	2,180	
	5	300	15	2,730	
Espantoso.....	5	225	11	1,500	2,200
	4	150	20	2,540	
	4	150	10	727	
Soldier.....	3	90	12	302	464
	3	75	10	272	
	.5	75	10	45	
McDonald.....	.16	240	9	42	60
	.33	300	10	120	
Buckhorn.....	.5	75	10	45	43
	.28	150	8	41	
	2.5	150	10	458	
Encenia.....	2	240	6	348	509
	4	150	10	727	

Near the center Caymanche Lake is about 200 yards in width. The ground near the lake is subject to flood in high-water periods. It is composed of an exceedingly rich black loam and is called locally of a "bayouky" nature. Going from the lake the ground rises gradually at first about 5 feet in 500 yards, and then is fairly level for a distance of about one-half mile or more. At the end of this stretch the rise is much more rapid. The land near the lake is covered with a fairly heavy growth of timber, mainly oak and mesquite. The average width of the "bayouky" country is between one-half and three-fourths mile, widening out toward the outlet of the lake.

There have been several plans for utilizing the water of these lakes for irrigation, but as yet no actual steps have been taken in the matter. The land lying near Rocky Lake has been bought with the idea of utilizing it for the growing of rice. Mr. J. S. Taylor had made plans for the erection of a dam across Caymanche Lake 1.75 miles long and 25 feet high, which he states would give a storage capacity of 12 by 3 miles, 15 feet deep.

CARRIZO SPRINGS.

With the exception of the irrigation from the Taylor dam, all irrigation around Carrizo Springs is carried on by means of water obtained from artesian wells. The proven artesian field in this vicinity is about 8 miles in width, running 16 miles southeast and an equal distance northwest of Carrizo Springs. The southwest line of the belt passes approximately through Carrizo Springs itself. The artesian strata evidently slope more rapidly than the ground toward the southeast, as is the general rule in all this part of Texas,

the result being that the artesian wells to the southeast are larger and deeper than those in the opposite direction, since the static pressure above the ground is greater, the general slope of the ground being toward the southeast.

The discovery of artesian water has made great increases in land values near Carrizo Springs. Lack of proper transportation facilities, however, is hampering at present the development of this region. A railroad line to either Eagle Pass or Cotulla, the nearest railroad stations, would be of the greatest assistance to the farmers.

The formation of earth usually encountered in drilling artesian wells north and east of Carrizo Springs is as follows:

Soil, 1 to 2.5 feet thick.

Clay, 2 to 10 feet thick.

Hardpan, 6 to 20 feet thick.

Sand rock (water does not rise from this, however), 16 to 20 feet thick.

Hardpan or soapstone, 25 to 75 feet thick.

Sand rock (water rises from this 10 feet), 8 to 10 feet thick.

This is followed by layers of soapstone and hardpan, below which is 20 to 30 feet of sand rock, the depth of this varying from 175 to 500 feet below the ground. This is followed again by soapstone, hardpan, and 100 feet of water rock, the latter being found at depths of 300 to 600 feet.

*Little farm.*—About 10 miles from Carrizo Springs, in the direction of Cotulla, is the farm of Mr. Little. Water is supplied by an artesian well 600 feet deep, 4.5 inches at the bottom and 5½ inches at the top. The flow is said to be 200 gallons per minute. Last year 23.5 acres were irrigated. Though it was a dry season, part of the well supply ran to waste.

A reservoir 40 by 100 yards at the bottom, with side slopes of 1 to 1.5, is being constructed. The top of the banks will be 6 feet above the ground, and the crown will be 5 feet wide. The owners of the place are building the reservoir themselves, at a cost of about 6 cents per yard of dirt. The banks of the reservoir are united to the subsoil of clay, the surface soil being removed.

Last year onions were grown on 16.5 acres on which no fertilizer was used. The onions were irrigated every eight days. The crop was harvested April 12, producing 25,000 pounds of white Bermuda onions per acre. They were spaced 4 inches apart, with a furrow between every other row of onions. The furrows were 2 feet 2 inches apart. Four inches was found to be too close to plant onions.

The land is owned by T. M. Berry and F. M. Shaw, who took charge of the place at the expiration of the Little lease during the summer. The owners will be able with the aid of the reservoir to irrigate 50 acres to be planted in alfalfa, corn, and onions. Corn was planted July 25.

*Hughes farm.*—Near the Berry-Shaw place is the Hughes farm, irrigated from an artesian well 640 feet deep, cased with 5⅜-inch



casing for 48 feet. The first flow was in sand rock at 350 feet. The well is in the center of a rectangular reservoir 130 by 40 feet. It takes the well ten hours to fill this reservoir 3 feet. This would mean a flow of 192 gallons per minute. The plant irrigated 50 acres of onions and corn, the water supply being just sufficient to irrigate every twelve days by the furrow system. Thirty-five acres were planted in onions and 15 acres in corn, the latter being planted in March and April. With the aid of the reservoir 3 acres per day were watered. Corn was irrigated every fifteen days in dry weather. One man looked after the irrigation.

The onions were spaced 3 by 18 inches. They matured May 1, and the yield was 16,000 pounds of red and white Bermudas per acre, which sold for 1.75 cents per pound. Transplanting the onions took 18 men thirty days and harvesting required the same amount of labor. No fertilizer was used on the land.

The rows were 150 feet long, and the water was turned into 10 to 15 rows, the time required for the water to flow through the rows being five to ten minutes.

The cost of putting down the well was \$1 per foot for the first 100 feet and 25 cents additional per foot for each succeeding 100 feet, without casing.

*Eardley place.*—A short distance from the Hughes farm is that of Mr. Eardley, irrigated by water from an artesian well 720 feet deep. The well started 12 inches and finished 10 inches in diameter. It is shut off by a valve when water is not desired. This well is by far the largest in this part of the country and is said to deliver a flow of 1,400 gallons per minute. It passes through three rock strata and is cased to the first stratum only with 10-inch casing. The flow of the well is used to irrigate 30 acres, 20 acres being in corn, planted April 1; 5 acres in onions, and 5 acres in truck. Corn was irrigated twice in the season and onions once a week. Only one-third of the flow of the well, it is estimated, was used to irrigate 5 acres of onions a day, requiring two or three irrigators. The onions were planted 4 inches apart in rows 18 inches on centers. The rows were 225 feet long, the land being very level. The main ditch is 4 feet wide and 18 inches deep. No fertilizer was used on the land. The yield of onions was 19,000 pounds per acre and of corn 35 bushels per acre. No reservoir was used in connection with the well, which should be capable of irrigating a tract much larger than the area at present watered.

*Patterson farm.*—Mr. Patterson owns 43 acres of irrigated land near the Eardley place. The water supply is obtained from two artesian wells, one of which is 600 feet deep, with 5½-inch casing, and the other 662 feet deep, 8 inches in diameter. An artesian water stratum is found at 240 feet, and a second one at 500 feet. The first well is cased for 90 feet down and cost \$1 per foot. The 8-inch well

is without casing. Each well flows 120 gallons per minute and discharges direct on the ground, no reservoir being used. The pressure of the wells was estimated to be 40 feet above the ground without flow. The second well irrigated 30 acres of corn, which was estimated by the owner to be its maximum capacity. The total irrigated area under both wells included 12 acres onions, 26 acres corn, and 5 acres truck. Of the 26 acres in corn, 3 were put in June corn, and yielded 40 bushels per acre. The remainder of the corn was planted in the spring.

Onions yielded 13,000 pounds per acre. They were spaced 5 inches apart in 18-inch rows. The onion furrows were 130 feet long, and the flow of one well was divided between 12 furrows at a time. Onions were irrigated three to six times, while corn was irrigated twice. The land was cultivated after each irrigation. The first onions, which were shipped April 10, brought 2 cents per pound in the field. The cost of hauling onions from Carrizo Springs to Cotulla, the nearest railroad point, is approximately one-half cent per pound.

The corn furrows were 400 feet long, and it took the water six hours to flow through them. All furrows were nearly level, and one well could irrigate an acre in twelve hours.

The soil is black waxy and black sandy about 18 inches deep, with a substratum of clay.

*Shaw farm.*—F. M. Shaw has 35 acres of irrigated land supplied with water from a 5 $\frac{3}{4}$ -inch well 380 feet deep, cased 60 feet. Water is found in sand rock, and will rise without flow at least 20 feet above the ground. The output of this well is said to be 150 gallons per minute. In connection with the well is a reservoir 178 feet inside top diameter, with a side slope of 1 to 1.5. The banks are clay 7 feet high and 6 feet wide on top. The reservoir cost 10 cents a cubic yard for material handled. It takes six days to fill the reservoir within 6 inches of the top. In a dry year Mr. Shaw figures that he could irrigate 30 acres. The crops grown were as follows:

Seventeen acres of corn, planted in March.

Twelve acres of alfalfa yielded 8 crops of 1 ton each per acre, irrigated by flooding after each cutting.

Six acres of onions yielded 23,000 pounds per acre.

The onions were spaced 4 inches apart in rows 12 inches apart. They were shipped the last of April and May. Onions and corn were irrigated by the furrow system. With the reservoir full and the additional flow of the well, 20 acres can be irrigated in two days, two men being needed to handle the water.

*McDaniel & McCaleb farm.*—This farm consists of 100 acres, irrigated with the flow of three wells. Two of the wells discharge into a reservoir 120 by 420 feet top inside measurements and 8 feet deep.

The reservoir fills with the discharge of these two wells at the rate of 1 inch in two hours. Allowing for the slope of the banks of 1 on 1.5 would, however, make the total output of these two wells 230 gallons per minute. The third well will deliver about 100 gallons per minute, and its reservoir is 120 by 210 feet at the top on the inside. The reservoirs were built by the owners of the land. In order to make the banks compact, teams with scrapers were driven around the reservoir on the embankment. The cost was estimated at 8 cents per yard of material handled.

The wells are about 400 feet deep and 6 inches in diameter. The first well mentioned is cased 86 feet, and the last two only 20 feet.

One of the ditches leading from the reservoir is made on top of a fill and is lined with 3 inches of clay, which was applied in the following manner: The ditch is 2 feet wide on top and 8 inches deep, curved in section. After the earth had settled the section was made uniform by dragging a board of the desired cross-section along the ditch. After this had been done the clay was hauled to the head of the ditch and mixed into a mortar, which was run down the ditch by the aid of water, another wooden templet being used to give the clay the proper shape. Two scrapers and four men could line 1,200 feet of ditch in three days. In applying the clay mortar it can be run up the ditch in the manner outlined to good advantage for a distance of 100 yards. In order to keep the clay from cracking a small supply of water is usually kept in the ditch. The ditch was given a fall of 1 inch in 64 feet. The method utilized of setting the ditch on proper grade was by means of a plumb bob attached to a T board. When the plumb line was a given distance off center, the ditch was at proper grade.

The irrigated land was planted 25 acres in onions, 25 acres in corn, 5 acres in sorghum, and 45 acres in truck. Eight acres of the onion land were subsequently planted to corn and tomatoes. The onions yielded 22,000 pounds per acre. No fertilizer was used last year, but this year the owners will use artificial fertilizer rather than manure, on account of the danger of Bermuda grass, which has been a source of great annoyance to farmers. Some of the onions, which were shipped as early as March 26, brought 5½ cents per pound. These were planted in September and transplanted November 1. They were planted 6 inches apart in rows 9 inches apart, the furrows being 3 feet apart. This made a furrow every 3 rows of onions. This year, however, the furrows will be 6 feet apart and the onions 4.5 inches apart, in rows 9 inches apart, there being accordingly one furrow for every 5 rows of onions. The owners are convinced that owing to the nature of the ground this system of irrigation will be perfectly satisfactory and that the onions will all receive sufficient water. This allows for closer planting than is customary.

Sorghum and corn were irrigated every fourteen days, truck every eight days. Furrows are 200 to 400 feet long, but the former are considered preferable. It takes the water about thirty minutes to run through the furrows, and 12 to 15 furrows are irrigated at a time. Part of the land which is hilly will be leveled off in order to put it in better shape for irrigation. This is a plan which might be followed elsewhere to good advantage.

The owners estimate that the flow of the wells, with the reservoirs, will irrigate 200 acres.

*Moore place.*—Mr. Moore has put down an 8-inch well 400 feet deep, cased 100 feet. At 175 feet a weak artesian flow was struck which increased somewhat at 215 feet. At 375 feet it received a considerable increase. This water will be used in irrigation.

*Arnold farm.*—This farm has an 8-inch well 480 feet deep delivering a measured flow of 40 gallons per minute. Seven acres of corn were irrigated from the well, water being applied every eight days. The flow of the well will irrigate 2 acres of new-plowed land in four twenty-four hour days and in the same time 5 acres of old land, the respective irrigation depths in inches being 1.7 and 4.2. The furrows are 400 feet long and it takes the water six hours to run through them.

The discharge pipe from the well stands 3 feet above the ground, thus forcing the well to work against needless additional head. The well is provided with a throttle valve and when this valve is closed water is forced up around the outside of the casing. This shows clearly the point previously mentioned in the chapter on wells—the possibility of considerable loss of water by opening a path of communication between artesian strata and other pervious strata.

*Shipp farm.*—Near the Arnold place O. E. Shipp has an irrigated tract supplied with water from two artesian wells, one of which is 365 feet deep with 55 feet of 4½-inch casing, and the other 417 feet deep with 65 feet of 6-inch casing. The owner estimates that the two wells can irrigate 30 acres without reservoir; with reservoir, a larger area. He thinks that there is a considerable loss of water from the wells, due to their being improperly cased. Water will rise without flow 18 to 20 feet above the ground. The first well has a flow of 15 gallons per minute and the second 25 gallons per minute.

The land is irrigated by the furrow system, the furrows being 300 to 500 feet long. It takes two to six hours to run the water through the furrows. Corn is irrigated twice a season, onions every ten days, truck every week, and sorghum and grapes every two weeks. Corn not irrigated yielded 30 to 35 bushels per acre, while irrigated corn yielded 40 bushels. The two wells will irrigate about 2 acres per day. The soil is of a black sandy nature, 18 inches to 5 feet deep, with a clay subsoil.

*Richardson ranch.*—The largest ranch in the vicinity of Carrizo Springs belongs to Asher Richardson and contains 550 acres of irrigable land, although at present only 400 acres have been irrigated. Water is furnished from two wells 650 feet deep cased down 90 feet. One well is 6-inch and the other 12-inch. Water rises without flow in these wells 75 to 80 feet. A circular reservoir 8 feet high and covering 7 acres is in course of construction. The base of the bank is 50 feet wide and the crown 8 feet wide. The reservoir will have a 6-foot clay core.

The two wells are 100 yards apart, and the second well did not affect the flow of the first. Artesian water was found at 390 feet and 650 feet in white sandstone. The output of the 6-inch well is 234 gallons per minute and the combined output of the two wells, as measured after the water from the 6-inch well had gone through 100 yards of ditch, was 520 gallons per minute. These outputs are by weir measurements made by the writer.

The land irrigated includes 100 acres of corn planted in February, receiving one irrigation; 200 acres of cotton, one irrigation; 75 acres of barley and oats, two irrigations a season; 25 acres of truck, irrigated every ten days. Having no reservoir, the land is irrigated day and night, and it requires seven days for the flow of the two wells to irrigate 100 acres of corn.

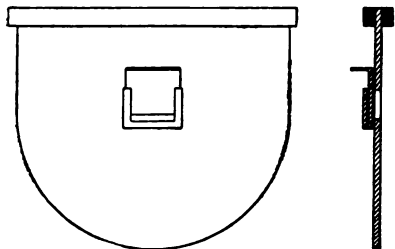

FIG. 65.—Regulating gate for laterals.

The furrows are 150 to 1,350 feet long, the average being 300 feet. The flow of the two wells was divided between 15 rows and took an hour to go through furrows 300 yards long. The rows were 3.5 feet apart for cotton. The main ditch was 3 feet wide and 1 foot deep, the slope varying from 1 in 1,000 to 3 in 1,000. The laterals had a slope of 1 in 1,000 and the furrows the same or less. The furrows in many places are curved. A marker was used on the plow to locate the next furrow in order to keep the lines parallel.

Gates were used in the laterals for regulating the supply of water and dividing the same properly. Some regulating gates used were made of a semicircular piece of sheet metal, provided with a slide in the center which could be forced down into the laterals. (Fig. 65.)

*Knight farm.*—Adjoining the Richardson place is the farm of Mr. Knight, containing 27 acres, which will be irrigated with water from an 8-inch artesian well 640 feet deep. The well delivers about 125 gallons per minute. Five acres of corn can be irrigated with the flow of the well in two days of twelve hours each. Two acres of

onions can be irrigated in one day. No reservoir is used. Last year 2 acres of onions and 15 acres of corn were irrigated. The onions were planted in December, spaced 4 inches apart in rows 16 inches apart. The flow of the well was divided between 30 furrows, taking about one and a half hours to irrigate the same. The yield of onions was 25,000 pounds per acre. In irrigating corn the water was turned into 8 furrows at a time and took about an hour to run through. The furrows are 150 feet long. No fertilizer was used.

*Pollard farm.*—Adjoining the Knight farm is the farm of Charles Pollard. It has a 10-inch well, 640 feet deep, cased 35 feet. The well formerly had a considerably larger flow than at present, but has filled up until it is now only 420 feet deep. The present flow is 120 gallons per minute and is used to irrigate 38 acres, no reservoir being employed.

In 1903-4 there were 24 acres in corn, 7 in sweet potatoes, and 7 in truck. This year 18 acres will be planted in onions and the same area in corn. The onions required irrigation every ten days and corn every fifteen days. The onions were planted 3.5 inches apart in 16-inch rows. They yielded 16,000 pounds per acre. It took twenty-five to forty hours' flow of the well to irrigate 8.5 acres of onion land a depth of 1 inch per irrigation. Forty-eight hours' continuous flow of the well was required to irrigate 4.5 acres of sandy land when very dry. Black sandy loam is considered best for onions.

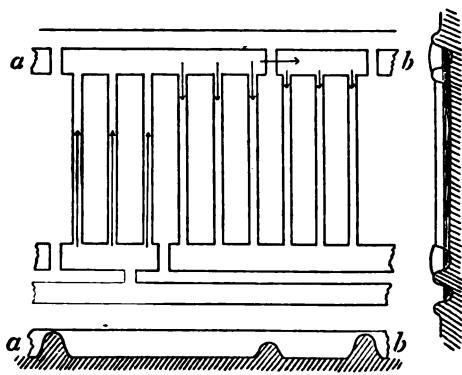

FIG. 66.—Furrow Irrigation in Texas.

Corn furrows were 200 feet long. The flow of the well was usually divided between 15 furrows, requiring about three hours to run through the same. Night irrigation of corn was carried on in the following manner: At the lower end of the furrows was a small ditch perpendicular to the same. This ditch was opened between the furrows, into which the water was turned, and a sufficient number of adjacent furrows, so that the water which ran down and through the ends of the furrows, being irrigated from the lateral, would go along the ditch and up the adjacent furrows, partially irrigating the same. (See fig. 66.) While this is somewhat wasteful of water, still it saves night attendance.

Considerable trouble has been experienced from smut spoiling the corn. The yield of corn was 25 to 40 bushels per acre.

*Jeffrey and Cowan farm.*—Augustus Jeffrey and W. C. Cowan own 12 acres of irrigated land, supplied with water from a  $5\frac{3}{8}$ -inch well 332 feet deep. Water is taken into an earth tank through a 2.5-inch pipe, which necessarily cuts down the supply. The tank is 60 by 100 feet at the top, inside, and 4 feet deep, the banks having a 4-foot crown and 20-foot base with slopes of 1 to 2. The well fills the tank at the rate of 4 feet in forty-eight hours, hence has a capacity of 50 gallons per minute. No trouble is experienced from seepage. Eight and one-half acres were planted in onions and the remainder of the area in corn and truck. The furrow system of irrigation is employed. Onions were spaced 5 inches apart in rows 14 and 18 inches apart, the irrigating furrows coming in the 18-inch intervals, with two rows of onions between. The yield was 9,000 to 10,000 pounds per acre. No fertilizer was used. Harvesting began April 10.

The flow was divided between four to six furrows and irrigated two-thirds of an acre per day of twelve hours. This rate of irrigation lowered the water in the reservoir about 6 inches. To irrigate  $1\frac{1}{2}$  acres of onions per day required two irrigators.

The land is quite level and is a red and chocolate sandy loam, the surface soil being 2.5 feet, underlain by a clay subsoil. The red sand bakes considerably. The owners consider waxy land best for onions. The onion land is set out in black-eyed peas, which will later be plowed under for fertilizer.

*Burton farm.*—This comprises 40 acres, subject to irrigation from two artesian wells, each  $5\frac{3}{8}$  inches in diameter and 400 feet deep, which discharge into a reservoir 450 by 100 feet, inside top dimensions, with banks 6 to 7 feet above the ground. The crown of the reservoir is 6 feet. It was built by contract at 10 cents per cubic yard for material handled. The wells fill the reservoir 6 inches in twenty-four hours, giving a flow of 103 gallons per minute for the two. This, of course, allows for seepage and evaporation in the reservoir.

Six acres were in onions, irrigated every eight to ten days. Three acres in sorghum received two to three irrigations per season. One acre in cane was irrigated every ten days. Eight acres in corn received two to three irrigations per season. Two and one-half acres in truck were irrigated every ten days. The 6 acres in onions were irrigated in two days' time, with a fall of 4 inches in the reservoir. The water used for this irrigation included, also, the flow of the well for thirty-six hours; hence 2 inches was the depth required for the irrigation. Two men irrigated 5 acres of corn in twelve hours. All irrigation was done by the furrow system, the onion furrows being 330 feet long. The flow as utilized was run into ten to twelve rows, and required fifteen minutes to run through them. The owner figures

that in very dry years the plant could irrigate about 20 acres to good advantage. The soil is a black sandy loam.

Onions were spaced 4 inches apart in 18-inch rows. They yielded 13,000 pounds per acre. After the onion crop was removed, the land was sown with black-eyed peas.

Some of the corn furrows were 900 feet long.

*Rector place.*—W. E. Rector has recently put down a 6 $\frac{3}{8}$ -inch well, 380 feet deep, delivering a flow of about 65 gallons per minute, with which he irrigated 3.5 acres last year and will irrigate 10 acres this year. Last year 1.5 acres of onions yielded 14,000 pounds.

*Foster place.*—J. P. Foster irrigates 12 acres with water from two 5 $\frac{5}{8}$ -inch wells, 384 feet deep and about 50 yards apart, delivering a flow of about 33 gallons per minute each. There is no reservoir on the land, and it is the common practice to irrigate only in the daytime, though occasionally the land has been irrigated at night. Mr. Foster estimates that when the second of his wells was sunk the first well decreased to about four-fifths of its previous flow. The cost of the wells was \$1 per foot.

Five acres were planted late in the season in onions, which were irrigated every twelve days. The yield was 8,000 pounds per acre.

Four acres were planted in corn in January and received two irrigations. Three acres were planted in truck, irrigated every three weeks.

Under good conditions it takes the combined flow of the wells two days of twelve hours each to irrigate an acre, though occasionally twice this quantity of water had to be used per acre. The onions were planted in rows 150 feet long. The water was divided between eight furrows and required forty minutes to run through them.

The soil is of a black and red waxy nature, about 18 inches deep, with clay subsoil.

*Moehrig place.*—Fritz Moehrig irrigates 30 acres from two 6 $\frac{1}{4}$ -inch wells, one 550 and the other 420 feet deep. The capacity of the wells is about 40 gallons per minute each. No reservoir is employed, and the owner figures that he can not irrigate more land with the present supply of water. Water for irrigation is seldom used at night.

Eleven acres were planted in onions, irrigated every seven days, and 10 acres in corn, which was planted in March and irrigated every fourteen days. Nine acres were planted in truck, irrigated every twelve days.

The land was irrigated by the furrow system, furrows being 200 to 300 feet long. One well irrigated five to eight furrows in one-half to one hour. When the onion land is irrigated every week, one well can irrigate an acre in ten hours, but when the irrigations are less frequent it will irrigate one-half this area in the same time.



The onions were spaced 4 inches apart in rows 16 inches apart. The yield was 14,000 pounds per acre. They were harvested April 1, and the land was subsequently planted in black-eyed peas, which were irrigated every two weeks.

The ground is black, red, and white sandy clay loam; 18 inches to 2 feet deep, which bakes when irrigated. The subsoil is clay.

*Owen farm.*—J. C. Owen irrigates 20 acres with the flow of two wells, one of which is  $5\frac{3}{16}$  inches in diameter and 636 feet deep. The main flow of this well, which is cased 60 feet, comes from the 315-foot level. The owner estimates that this well delivered 60 gallons per minute, though this has now been reduced about one-half, owing to the other well, which was sunk 400 yards away. The flow of the first well was very much throttled, being led into a reservoir through two 1.5-inch pipes. The reservoir is 100 by 300 feet, top inside measurements, and 6 feet deep. Its banks are sloped 1 to 2.

The second well is  $6\frac{1}{4}$  inches in diameter and 360 feet deep, delivering about 60 gallons per minute. The owner will build another reservoir, with the intention of irrigating 40 acres with the aid of a third well. The ground level of the second well is 4 to 5 feet lower than at the first well, which accounts for the increase in discharge.

Ten acres were planted in corn, irrigated every ten to fifteen days. Seven acres in cotton received two irrigations per season; 2 acres in cane, the same, and 1 acre in truck was irrigated every eight days. Ten acres of corn can be irrigated in three days with the combined flow of the wells and reservoir.

*Kendall place.*—W. L. Kendall irrigates 15 acres from a 4-inch artesian well 406 feet deep, said to deliver 87 gallons per minute. The land was planted in onions and corn, the latter being sown in March and July.

A reservoir has been constructed, 60 by 30 yards inside top dimensions and 6 feet deep. The banks are built up with clay core, but the reservoir leaks slightly.

The land is irrigated every eight to ten days, and with the well and reservoir the owner figures that 15 acres is about the limit of capacity.

A 3-inch artesian well 357 feet deep supplies water to stock.

*Oden farm.*—Sixteen miles north of Carrizo Springs, J. Oden has 48 acres under irrigation. Water is supplied from a  $4\frac{1}{4}$ -inch well 449 feet deep, cased 165 feet. The owner thinks it should be cased 330 feet to prevent caving, as it is necessary occasionally to clean out the well. The casing is landed in rock 8 feet thick.

A reservoir 8 feet high and 125 feet inside bottom diameter is being constructed for use in connection with the well. The banks will have a slope of 1 to 2 and the crown will be 8 feet.

Fifteen acres were planted in corn, 17 in broom corn, 6 in cotton, and 10 in truck. The furrow system of irrigation was used, the fur-

rows being 30 to 100 yards long. The well will irrigate 2 acres in twelve hours. The water was divided between 10 to 15 short furrows and between 5 to 6 long furrows at a time.

The cost of boring the well was \$1 per foot for the first 500 feet, the owner furnishing the casing. The well has a head without flow of 12 feet above ground, and is said to have a capacity of 300 gallons per minute.

*English farm.*—Mr. English irrigates without reservoir 100 acres with two 6-inch wells 380 feet deep, delivering 75 to 100 gallons per minute.

#### PEARSALL.

The soil in this vicinity is mainly of a light sandy nature. Near Pearsall are several small irrigation plants which derive their water supply from pumped wells.

*Maney farm.*—About 4 miles southeast of Moore is a plant owned by E. P. and Mason Maney, which derives its supply of water from two 5½-inch wells 100 feet deep. A 4-horsepower gasoline engine operates two deep-well pumps, 3¼ by 36 inches, delivering, when running at 30 strokes per minute, 50 gallons per minute per pump. The pumps lowered the water in the wells over 20 feet. The pump cylinders are 75 feet from the surface of the ground. The level of standing ground water was 35 feet below the surface of the ground. The pumps elevated the water 4 feet above the ground and utilized 5 to 7 gallons of gasoline in ten hours, at a cost of 18 cents per gallon.

The wells discharge into a storage tank 60 feet base inside diameter and 80 feet top inside diameter, with a depth of 3.5 feet. The base of the reservoir bank is 20 feet and the crown 6 feet. The banks are composed of stiff clay. The cost of the reservoir by contract was \$50. There is considerable loss from seepage from the reservoir and no attempt has been made to puddle or tamp the earth. One and one-half to 2 inches of water are lost per night due to this cause. The water comes from a porous sand rock which extends from 42 feet down to 100 feet below the ground. The wells are cased 44 feet.

Nine acres of onions were irrigated by the plant and yielded 100,000 pounds gross. No fertilizer was used on the ground, which was irrigated every six to ten days. It was necessary to run the pumps four nights during the irrigation season. The bed system of irrigation was used, the beds being 12 to 30 feet wide and 70 yards long. The plant could irrigate one acre in ten hours. The soil is 2 to 6 feet deep.

It takes fifteen hours' pumping to fill the reservoir, and with the reservoir full and the pumps running 3 acres could be irrigated in six hours.

*Harkness farm.*—A. C. B. Harkness irrigates 4 acres at Pearsall with water from a  $5\frac{3}{8}$ -inch well 100 feet deep, the water-bearing stratum being sand rock. Ground water stands 45 feet below the surface of the ground and the end of the suction pipe in the well is 70 feet below the ground. A deep-well pump,  $3\frac{3}{4}$  by 30, run at 38 strokes per minute, delivering a flow of 60 gallons per minute at an elevation of 4 feet above the ground, is operated by an 8-horsepower gasoline engine, consuming 5 gallons in ten hours. The land produced 15,000 pounds of onions per acre. On the same farm was a 6-inch well 150 feet deep. The cost of these wells was 50 cents per foot. No casing was used as it was found to be unnecessary.

*Hess farm.*—W. D. Hess irrigates 6 acres with water from two pumped wells, 105 and 108 feet deep, respectively. The water stratum is sand rock and runs from about 60 to 95 feet below the ground. The wells are cased for a distance of 12 feet. A 6-horsepower gasoline engine drives two deep-well pumps,  $4\frac{1}{2}$  by 28 and  $3\frac{3}{4}$  by 36, respectively, lifting the water 7.5 feet above the ground. The combined flow of the pumps is 125 gallons per minute. The engine uses 5 gallons of gasoline in ten hours, the cost being 15 cents per gallon. Ground water stands 38 feet below the ground. The ends of the suction pipes in the wells are 75 and 85 feet, respectively, below the ground.

The pumps discharge into a reservoir 75 feet square inside bottom, 7.5 feet deep, crown 4 feet, and width of base of bank 34 feet. The pumps will fill the reservoir in forty hours. There is a coating of clay 4 inches thick on the inside of the reservoir, which was built by the owner at a cost of \$170, or about  $7\frac{1}{2}$  cents per yard.

One and one-third acres were planted in onions, irrigated every eight days. Four and two-thirds acres were planted in truck, irrigated every twelve days. The pumps without the reservoir will irrigate 1 acre in twelve hours. Fully 2 acres can be irrigated with the reservoir alone. Onions are irrigated by the bed system, the beds being 10 feet wide by 200 feet long. The beds were flooded crosswise, but next year will be irrigated by flooding from the end, as is done in other sections. The onions were placed 5 inches apart in rows 14 inches on centers. Twenty tons of stable manure per acre were used for fertilizer. Cowpeas have been planted this year. The onions were planted late, and owing to this cause the yield was but 10,000 pounds per acre.

*Patterson farm.*—Tom Patterson irrigates 8.5 acres with water from a  $5\frac{3}{8}$ -inch open bottom well 240 feet deep, water being in a purple sand stratum cased 216 feet. A 4-horsepower gasoline engine drives a  $3\frac{3}{4}$  by 24 inch deep-well pump, running 38 strokes per minute and delivering a flow of 45 gallons per minute. Ground water stands 60 feet below the level of the ground and is elevated by the pump 6

feet above the ground. The end of the pump cylinder is 160 feet below the ground. The engine consumes 6 gallons of gasoline in ten hours at a cost of 18 cents per gallon. The pump discharges into an earth tank 40 by 80 feet inside base measurement, 4.5 feet deep, side slope 1 to 2. The pump will fill the reservoir 1 foot in ten hours. One-half tankful will irrigate 1.5 acres of onions in three hours. One tankful can irrigate the entire acreage in melons.

Seven acres were planted in watermelons and 1.5 acres in onions. The furrow system of irrigation is used, the furrows for onions being 2 feet apart with 2 rows of onions 8 inches apart between each pair of furrows, and the furrows for melons being 12 feet apart. Onions were spaced 6 inches apart in rows which were 70 yards long. The average length of time required for water to flow through the furrows was 5 minutes.

*Trickey farm.*—W. Trickey irrigates 23 acres with water from an 8-inch well 121 feet deep and a 6.5-inch well 201 feet deep, each well having 6 feet of casing. The water stratum runs from 65 to 121 feet below the ground. The ground water stands 46 feet below the ground surface and the bottom of the cylinders of the pumps is 60 feet below the ground level. A 6-horsepower gasoline engine drives a 3 $\frac{3}{4}$  by 31 inch and a 3 $\frac{3}{4}$  by 36 inch deep-well pump, running at a speed of 33 strokes per minute. The water is lifted 6.5 feet above the ground. The engine consumes 5 gallons of gasoline per ten hours, the cost of same being 17 cents per gallon. A 300,000-gallon reservoir, 60 by 75 feet bottom inside dimensions, 7 feet high, side slope 1 to 2, crown 3 feet, is used in connection with the pumps, which deliver a combined flow of 110 gallons per minute.

Seven acres planted in onions were irrigated every ten days; 2 acres in alfalfa were irrigated every two months; one-half acre in ribbon cane, 2 acres in tomatoes, 1 acre in cabbage, 9 acres in sweet potatoes, 1 acre in truck, and 1 acre in beans were irrigated every three weeks.

Commonly the ground is irrigated from the pump without the reservoir. Four acres of onions can be irrigated in twelve hours without the reservoir.

Onions are irrigated by the furrow system, the rows being 14 inches apart and the onions spaced 5 inches apart. The length of the furrows is 125 feet and the flow of the pumps was divided between five furrows. The onions were planted late and no fertilizer was used. The yield was 9,300 pounds per acre. It is intended to plant cowpeas on the onion land. Sweet potatoes took practically the same quantity of water as onions.

Alfalfa was irrigated by flooding, the beds being 30 by 60 feet, and was used for grazing. On the farm were 150 peach, pear, and plum trees, which were doing well.

*Berry farm.*—J. E. Berry irrigates 7 acres 4 miles south of Moore with water from a pumped well. The end of the pump cylinder is 60 feet below the ground level. A 6-horsepower gasoline engine runs a 3 $\frac{3}{4}$  by 30 inch pump. Three acres were planted in onions, 1 in tomatoes, and 3 in corn and cantaloupes. The onions were planted late and yielded 8,000 pounds per acre.

*Bennett farm.*—John Bennett irrigated 10 acres near Derby with water pumped from a 10 and an 8 inch well, each of which is 200 feet deep. The ground water is 40 feet and the pump cylinders 60 feet below the ground level. A 2 $\frac{1}{2}$ -horsepower engine drives a deep-well pump supplying 50 gallons per minute to a reservoir, and a 6-horsepower gasoline engine is utilized for driving another pump delivering 70 gallons direct to the land. The land was planted in onions, which yielded 10,000 pounds per acre.

*Coker farm.*—J. M. Coker irrigates 16 acres near Devine by pumping water from a well 110 feet deep. The pump is a 4 $\frac{3}{4}$  by 20 inch deep-well and runs 30 strokes per minute. The consumption of gasoline is 6 gallons in ten hours. A tank 55 by 22 yards inside top measurement by 8 feet deep is utilized in connection with the pump. In twelve hours the supply of the tank and pump can irrigate 4 acres. The crops grown are onions, sweet potatoes, and truck.

Starting about 12 miles southeast of Pearsall there are 15 artesian wells 165 to 675 feet deep delivering a flow of 10 to 85 gallons per minute. These wells belong to the Keystone Land and Cattle Company and are used for stock purposes.

In the vicinity of Pleasanton there are also several small artesian wells, used mainly for stock purposes.

Mr. Harry Landa, of New Braunfels, who owns the land where the springs supplying the Comal River are situated, has made a park of the surrounding country, which is one of the garden spots of Texas. The waters of Comal River, clear as crystal, gush forth from the rocks and flow into a small artificial lake, whence the greater part of the water is diverted into a canal, through which it flows about one-half mile into the fore bay for supplying power to two 350-horsepower turbines, one of which drives a cotton-seed oil mill, a corn sheller, and two No. 5 centrifugal pumps for supplying adjacent fields with irrigation water; the other operates a corn mill, flour mill, ice plant, and electric lighting and power plant. The fall is about 21 feet when the river is very low. High water in the Guadalupe River, which seldom occurs, cuts this figure in two.

These centrifugal pumps run about 700 revolutions per minute and deliver a measured flow of 350 gallons per minute each. They discharge through about 300 feet of 6-inch pipe into wooden pressure boxes 12 by 12 by 15 feet. From there the water is distributed through 8 and 10 inch sewer pipes to hydrants, the farthest of which

is about 1,500 feet distant. It takes about two and one-half hours to irrigate an acre with the flow of one pump when the ground is dry, but not cracked. This is equivalent to a depth of 1.95 inches per irrigation.

The hydrants which supply the fields with irrigation water are peculiar in construction. As will be seen by referring to figure 67, water is admitted through a supply pipe *a*, which connects with the pressure box. The water level will stand at *l*. Water is supplied through the opening *h* to the outlet *o*. The plugs *p*, faced with leather and usually provided with iron handles, serve to cut off the flow of water from hydrants from which it is not desired to irrigate. The hydrants are constructed of brick and are about 6 feet high. They are usually provided with 12-inch plugs for the outlets. This plant of two centrifugal pumps supplies two fields with water, which is distributed a considerable distance with practically no loss.

From the lake in Landa Park there is another outlet besides the canal, which supplies the turbines. The water from this source is used to drive an undershot wheel, which in turn drives a rotary pump with an 8-inch discharge pipe, which supplies a reservoir on top of a hill near by with a flow of about 500 gallons per minute. Water is taken from this reservoir through an iron pipe into a pressure box and thence distributed to hydrants in the manner already described. The land is rented, and water is supplied for one-half of the crop produced. The renter is also furnished, free of cost, with wagons and stock.

The flow of Comal River through the canal was measured August 18, 1904, and was 236 cubic feet per second. The irrigated land is all of a black waxy consistency. The principal crop raised was onions, which were harvested May 1. In order to make an attractive appearance for sale the onions were all washed off after harvesting. The yield averaged 24,000 pounds to the acre, the maximum yield being 39,000 pounds. Onions and potatoes were irrigated about every twenty days by the furrow system, the onions receiving about seven irrigations and the potatoes three or four irrigations per year.

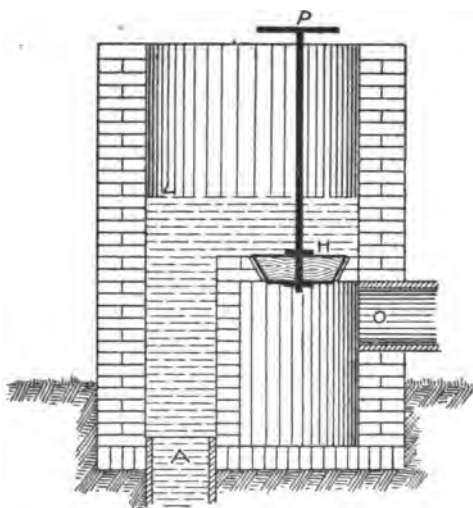

FIG. 67.—Hydrant in use at New Braunfels, Tex.

The two 5-inch pumps irrigated 70 acres, of which 39 were planted in onions, 30 in potatoes, and 1 in truck. Potatoes averaged 200 bushels per acre. The cost of labor was 75 cents to \$1 per day.

#### ALTGELD RANCH.

About two miles south of New Braunfels is a ranch owned by Mr. Altgeld, supplied with water from a spring 60 feet deep, which on August 18, 1904, gave a measured discharge of 120 gallons per minute. This spring is situated in the center of a small pool or tank, which can be used for a limited storage of water. According to Mr. Altgeld's observation the spring water will rise without flow to a height of only 2.5 feet above its present level. He is at present constructing a much larger tank in addition to the present basin and figures on the installation of a pump. Owing to the small hydrostatic head available for causing flow from the spring, it is natural to expect that there would be great increase in the amount of water supplied and that good results could be obtained by the installation of a pump. Ten hours' flow of the spring was required per acre irrigated by bed flooding when the alfalfa was on level ground. This is equivalent to a depth of 2.7 inches per irrigation. When the alfalfa is on hillside 2.5 acres are irrigated in the same time. This would mean a depth of water of only 1.1 inches. As the hydrostatic head of the spring is so small the flow may vary considerably in a short time from changes in the head of the spring. For the irrigation of corn the flow of this spring in ten hours will irrigate 2 acres. This would mean a depth of 1.3 inches per irrigation. Alfalfa produces five or six crops of a ton each per acre and \$15 a ton is the average price realized. One acre of unirrigated land produced 25 bushels of corn to the acre. An acre next to it irrigated gave a yield of 75 bushels. Land in the vicinity of New Braunfels not subject to irrigation can be bought for \$50 an acre, whereas irrigated land brings \$150.

#### TESTS OF PUMPS AND IRRIGATION PLANTS.

The following tables contain results of tests of irrigation and pumping plants at San Antonio and Beeville.

The first table gives the results of tests to ascertain the quantity of water applied for irrigation. The land near Beeville was nearly all of a black, sandy description, while the land at San Antonio was of a black, waxy variety.

The headings of the table explain fully the results.

At Beeville the Grissett farm was the only one which did not employ a reservoir, but pumped water directly onto the land. None of the plants at San Antonio used reservoirs.

*Irrigation tests.*

Name.	Area irrigated.	Depth of irrigation.	Time since last irrigation.	Condition of soil.	Kind of soil.	Spacing of furrows.	Rate of flow per furrow per minute.	Time required to run through furrow.
	<i>Acres.</i>	<i>Inches.</i>	<i>Days.</i>			<i>Feet.</i>	<i>Galls.</i>	<i>Minutes.</i>
<b>Beeville:</b>								
Muckleroy .....	0.11	0.83	60	Very dry	B. S. <sup>a</sup>		27	
Mock .....	.06	.43	5	Dry	B. S. L. <sup>a</sup>	254 by 1.6.	34	7
	.07	.20	1		do			
	.09	.30	1		do			
Grissett .....	.43	1.51		Dry	B. S. L. <sup>a</sup>	254	24	
	.08	.75	10	do	L. S. L. <sup>a</sup>	310 by 3.	28	32
	.05	.26	2	Moist	do	240 by 2.5.	16	11
McDowell .....	.05	1.19	160	Very dry	do	396 by 3.	24	8
	.04	.83	3	do	do	396 by 3.	22	41
	2.13	1.02	8	Fairly moist.	B. S. L. <sup>a</sup>			
Rankin .....	1.33	1.55	10	do	do			
	1	1.67	8	do	do			
	.03	.75	10	do	do	468 by 3.	30	20
	.06	.85	11	do	do	468 by 3.	22	35
	.06	1.11	18	do	do	468 by 3.	24	41
	.13	1.22	21	Dry	do	480 by 3.	14	80
Elliott .....	.03	1.26	16	Fairly moist.	do	468 by 3.	55	20
	.07	1	30	Dry	do	480 by 3.	19	47
	.07	.30	.5	Wet	do	480 by 3.	27	12
	.10	1.18	30	Dry	do	480 by 3.	19	57
	.07	.30	.5	Wet	do	480 by 3.	17	21
<b>San Antonio:</b>								
<b>Meerscheidt:</b>	1.03	7.15		Dry				
	4.40	7.80			B. W. <sup>a</sup>			
	8.20	6.28			do			
	.81	3.57			do			
	.33	9.30			do			
<b>Wautrs:</b>	1.06	1.54			do			
	.81	4.13			do			
	.55	6.94			do			
	1.66	4.13			do			
	6.04	4.10			do			
	5.06	5.30			do			
<b>Collins:</b>	3.13	4.78			do			
	4.03	3.67			do			
	2.95	9.13			do			
	3.14	6.45			do			
	6.50	6.70			do			

<sup>a</sup> B. S. = black sandy; B. S. L. = black sandy loam; L. S. L. = light sandy loam; B. W. = black waxy.

*Summary of irrigation tests.*

Name.	Area irrigated.	Depth of irrigation.	Quantity of water applied.
	<i>Acres.</i>	<i>Inches.</i>	<i>Acre-in.</i>
<b>Beeville:</b>			
Muckleroy .....	0.11	0.83	0.09
Mock .....	.22	.90	.07
Grissett .....	.43	1.51	.65
McDowell .....	.22	.75	.17
Rankin .....	3.46	1.33	4.60
Elliott .....	.62	1.13	.70
<b>Total</b> .....	<b>5.06</b>	<b>1.24</b>	<b>6.28</b>
<b>San Antonio:</b>			
<b>Meerscheidt—</b>			
Gasoline .....	1.03	7.15	7.37
Steam .....	12.90	6.80	85.70
Wautrs .....	5.33	3.75	20.00
Collins .....	30.90	5.50	170.00
<b>Total</b> .....	<b>49.86</b>	<b>5.68</b>	<b>283.07</b>

The table brings out most prominently the relation between depth of water used in comparison with the supply. The farms at San Antonio had a much larger supply on which to draw and used the



water much more extravagantly than at Beeville, the average depth of irrigation at Beeville being 1.24 inches and at San Antonio 5.68 inches, or nearly five time as much.

The following table gives the results of tests of gasoline pumping plants. All of the pumps at Beeville were of the deep-well variety. The pump at Meercheidt's was centrifugal. The ratio of explosions to misses was in most cases very small, the engines being much under-loaded. As a result the consumption of gasoline per horsepower hour was exceedingly high, and the cost of operation considerably greater than it should be. Deep-well pumps should operate under not over half a gallon of gasoline per water horsepower hour.

*Results of tests of gasoline pumping plants.*

	Muckle-roy.	Mock.	Grissett.	McDowell.	Rankin.	Meer-scheidt.
Pump:						No. 6.
Size.....inches.....	3½ by 24	2½ by 13½	3½ by 20½	2½ by 10	3½ by 24	
Speed.....rev. per min.....	29	28	27½	47	31½	
Engine:						
Size.....horsepower.....	2½	1½	4	1½	2	12
Speed.....rev. per min.....	360	328	268	390	300	
Explosions.....per min.....	32	44	102	43	50	
Misses.....do.....	143	120	27	152	140	
Engine load.....per cent.....	18	27	79	22	26	100
Head.....feet.....	44.5	92	59	61.5	63	53.1
Rate of flow.....gals. per min.....	28	5.4	28	11	36.5	433
Water horsepower.....	.314	.125	.417	.171	.58	3.63
Gasoline per hour.....gals.....	.422	.136	.35	.274	a .394	1.43
Gasoline per water-horsepower hour.....gals.....	1.34	1.09	.84	1.06	a .68	.394
Gasoline per acre-foot raised 1 foot.....gals.....	1.84	1.49	1.15	2.27	a .96	.54
Gasoline per acre-foot, gallons.....	82	187	68	140	a 59	47
Cost of gasoline per gallon, cents.....	14	14	14	14	14	13
Cost of gasoline per water-horsepower hour.....cents.....	18.8	15.3	11.8	23.2	a 9.5	5.1
Cost of gasoline per acre-foot raised 1 foot.....cents.....	25.7	20.9	16.1	31.8	a 13	7
Cost of gasoline per acre-foot.....	\$11.40	\$19.20	\$9.50	\$19.50	a \$8.00	\$2.30

<sup>a</sup> Average of several observations.

The following table shows the results of tests of two steam pumping plants in San Antonio. In test No. 1 there was a leak in the suction side of the pump, resulting in a very low vacuum and consequent inefficient operation of the pump. The weight of water evaporated was calculated from the amount of water supplied to the boiler by the pump, no allowance being made for the moisture in the steam delivered to the engine. In the Meerscheidt plant the boiler was fed by a pump, no allowance being made for the steam used by the pump, which is hence credited to the engine. The Wautrs plant used an injector instead of a pump for boiler feed water. If saturated steam is supplied to an engine, the weight of the steam consumed per horsepower is dependent on the difference of temperatures between the entering steam and exhaust. The line marked "Theoretical pounds of steam per horsepower hour" represents the amount

of steam required provided the engine were operated at 100 per cent efficiency. In the next line is given the engine efficiency, which is the ratio of theoretical steam consumed by the engine to the steam per indicated horsepower hour. In the next line is the given efficiency of the engine, allowing 8 per cent of the apparent steam consumption for moisture and for operating the feed pump. In the last column is given the total combined engine and pump efficiency, which is the ratio of the total energy output of the pump to the energy which is furnished by the required weight of steam, with 8 per cent allowance, as above.

*Tests of steam pumping plants, San Antonio, Tex., 1904.*

	Meerscheidt & Stieren.			Wautrs.
Boiler:				
Type.....	Horizontal M. T.....			Vertical M. T.
Size.....	80 H. P.....			12 H. P.
Engine:				
Type.....	Simple automatic noncondensing.....			
Size.....	80 H. P., 12 inch by 16 inch.....			
Pump:				
Type.....	Centrifugal special.....			Direct-acting steam.
Size.....	No. 8.....			
Kind of fuel.....	Lytle coal.....			Mesquite roots.
Cost of fuel..... per ton	\$1.75.....			
	Test 1.	Test 2.	Test 3.	
Consumption of fuel per hour..... pounds.....		733	718	111.
Water evaporated per pound of fuel..... do.....		3.20	3.11	2.07.
Water evaporated per pound of fuel from and at 212° F..... pounds.....		3.55	3.46	2.42.
Steam per I. H. P. hour..... do.....		41.3		
Steam per W. H. P. hour..... do.....		75		205.
Fuel per I. H. P. hour..... do.....		12.9		
Fuel per W. H. P. hour..... do.....		23.3		103.
Fuel per acre-foot raised 1 foot..... do.....		31.9		141.
Fuel per acre-foot pumped.....		1,620		4,350.
Water evaporated per hour..... pounds.....	1,790	2,340	2,290	229.
Cost of fuel per acre-foot raised 1 foot..... cents.....		2.8		
Cost of fuel per acre-foot pumped.....		\$1.42		
Cost of fuel per W. H. P. hour..... cents.....		2.04		
I. H. P.....		56.7		
Head..... feet.....		50.8		90.9.
Discharge..... g. p. m.....		2,417		142.
Water horsepower.....		31.2		1.074.
Combined pump and engine efficiency..... per cent.....		55		
Temperature of feed water..... ° F.....	140	140	140	75.
Steam pressure..... pounds.....	89	76	68	62.
Engine..... r. p. m.....	177	174	166	64. <sup>a</sup>
Pump..... do.....	407	403	383	
Suction gauge, inches in mercury.....	10.6	22.2		25.
Calculated head lost in friction in discharge pipe and velocity head..... feet.....		3.6		
Lift..... do.....		21.4		2.6.
Theoretical pounds steam per H. P. hour..... pounds.....	18	19.4		21.3.
Engine efficiency..... per cent.....		41		
Engine efficiency, allowing 8 per cent for moisture and steam for feed pump..... per cent.....		51		
Engine and pump efficiency, allowing 8 per cent for moisture and steam for feed pump..... per cent.....		28.1		11.3.

<sup>a</sup> Strokes per minute.

During test No. 1 there was a leak in the suction of the pump, thus cutting down the discharge and also the head against which the pump operated. In test No. 2 the combined efficiency of the pump

and engine, which is the ratio of the water horsepower output to the indicated horsepower, is 55 per cent, which is a good result. The engine efficiency of 51 per cent is also not bad, considering that the engine is operating under about 70 per cent load. The water evaporated per pound of fuel is exceedingly low. This, however, is due to the poor grade of fuel which is used; owing to this the fireman was hardly able to keep up steam during the test.

The results of the test of the Wautrs plant gave a steam consumption per horsepower-hour of 205 pounds, as against 75 pounds with the Meerscheidt plant. This is due to the poor efficiency of the direct-acting steam pump. Although the boiler is considerably smaller, still the results of evaporations show that 1 pound of coal used in the Meerscheidt plant performed the same amount of evaporation as  $1\frac{1}{2}$  pounds of wood. This would give an equivalent evaporation efficiency in the two cases of 1 ton of coal against 1 cord of wood weighing 3,000 pounds.

#### SUMMARY.

Several tables have been prepared to summarize the results of the foregoing investigations. The figures given in the tables are derived mainly from the data in the text and are based largely upon information furnished by the farmers and not upon actual measurements; hence there will undoubtedly be found discrepancies in results in individual cases. Still, the number of plants is so large that possible individual errors will be greatly minimized in the average results. The tables of performances of plants are useful not alone for statistical purposes but to indicate the sources of undue expense, as well as the means by which this may be avoided. The results shown in these tables point very clearly to methods by which considerable improvement may be expected over present conditions. In the preparation of the tables assumptions have been made, mainly with regard to cost of fuel and labor, only where the conditions of neighboring plants seem to warrant the same. There are two kinds of averages, viz, the straight and the weighted. For example, the average flow per acre for several farms may be secured in two ways: (1) The straight average will be secured by dividing the sum of the averages for the several farms by the number of farms; (2) the weighted average will be secured by dividing the total flow to all the farms by the total acreage. The straight average is probably of more value from the agricultural point of view, since it gives the results attained on the average farm and is a good indication of what others may expect to do. The weighted average is better for statistical purposes, because it is the true average per unit of area.

**AREA AND CROPS.**

In the districts investigated there were approximately 30,000 acres of irrigated land, devoted more largely to rice than to any other one crop. The following table gives the recorded acreages of the various crops:

*Areas of crops in districts investigated.*

Crop.	Area irrigated.	Percentage.	Crop.	Area irrigated.	Percentage.
	<i>Acres.</i>			<i>Acres.</i>	
Truck.....	2,917	10	Sorghum.....	147	1
Onions.....	462	2	Johnson grass.....	1,871	5
Corn.....	4,843	17	Rice.....	18,325	48
Cane.....	966	4			
Alfalfa.....	1,447	5	Total.....	27,780	100
Cotton.....	2,278	8			

**METHODS OF IRRIGATION.**

The methods of irrigation at present in use are mainly furrow, check, bed, and tablet systems. In the matter of adopting a system of irrigation there is a strong tendency for each man to imitate his neighbors. Thus one is almost certain to find the same system of irrigation used exclusively throughout any district, independent of whether it is suitable for conditions encountered. The system of irrigation most commonly used in Texas is the furrow system. Usually the water for irrigation is turned into a temporary head ditch, from which it is divided among several furrows. This system necessitates the constant attendance of the irrigator to see that the water is evenly divided among the different furrows. The furrow system of irrigation, which is now being used in California, governs the flow of water to different furrows by small wooden boxes or pieces of pipe set temporarily in the head ditch opposite each furrow. This system insures an equal distribution of water among the different furrows, removing the danger of the ground at the entrance to the furrow washing away and hence distributing the water unequally. It enables an irrigator to accomplish much more work in a given space of time, as, after once the water has been started into the furrows no further attention is required until the irrigation is completed. The old-fashioned method, however, of furrow irrigation prevails throughout Texas, no devices being used for controlling the flow at the entrance.

In onion culture the bed system is in common use. The land is laid out in beds about 12 feet wide and 100 to 200 feet long. Between the beds small levees are thrown up. The supply ditch runs along the head of the beds, and water which is admitted to them from this ditch flows along the beds in the form of sheet, covering the entire ground. This method is used occasionally for alfalfa and truck.

In the tablet system of irrigation the ground is laid off in rectangles, called tablets, from 30 to 40 feet wide and 150 to 500 feet long. At the head of these tablets is the ditch, which supplies water in turn to ditches running between tablets. From these ditches the tablets are watered by making cuts in the bank, from which the water is spread out to irrigate part of the length of the tablet. When this is wet the ditch bank is closed and another break made to irrigate farther down, and so on at as many places as may be necessary to irrigate the field. The boundaries of the tablets running lengthwise are alternately levees and ditches.

The check system of irrigation is used principally for rice, and sometimes for alfalfa. The basin system is used to a limited extent for the irrigation of trees. In the distribution of water, in some places canvas dams are used in lateral ditches to cut off the lower part of the ditch. Some more permanent installation, such as wooden gates and drops, would be decidedly preferable, as the additional cost of installation would soon be saved through smaller expenditures for labor.

The following table brings together the information collected as to sizes of beds and tablets, lengths of furrows, etc. The abbreviations in the column showing kind of soil are as follows: B. S., black sandy; B. W., black waxy; S., sandy; L. S., light sandy; A., alluvial; B. L., black loam.

*Irrigation practice.*

No. of plant.	System.	Length of furrow or bed or area of check.	Distance between furrows or bed width.	Rate of flow per furrow or bed.	Time required to run through furrow or bed or into check.	Kind of soil.
			<i>Feet.</i>	<i>Gallons per minute.</i>	<i>Minutes.</i>	
1	Check	0.5-8 acres				B. W.
2	do	8 acres				B. W.
3	do	To 40 acres				B. W.
5	do	1-15 acres				B. W.
6	do	3-25 acres				B. W.
16	do	To 200 acres				B. W.
19c	Bed	300-600 feet	10.0			B. W.
19d	do	do	10.0			B. W.
20	Furrow	450 feet			105	B. W.
29	do	225 feet			15	B. W.
30	do	360 feet			60-300	B. W.
31	do	300 feet	3.0		60-240	B. W.
32	do	do	3.5		To 600	B. W.
34	do	200 feet			30-60	B. W.
34.5	do	300 feet				S.
35	Bed	110 feet	13.0			B. S.
37	do	100 feet	12.0		10	A.
37	Furrow	200-600 feet				A.
38	do	750 feet			60	B. S.
39	Bed	100 feet	12.0		7	B. S.
48	Furrow	310 feet	3.0		30	S.
49	do	50-400 feet	3.0	20	8-41	L. S.
53	do	254 feet	1.6	34	7	B. S.
54	do	470 feet	3.0	25	12-80	B. S.
60	do	To 600 feet				B. W.
86	Bed	400-700 feet	50.0			A.
87	do	150 feet	30.0			A.

\*Average 38.

*Irrigation practice—Continued.*

No. of plant.	System.	Length of furrow or bed or area of check.	Distance between furrows or bed width.	Rate of flow per furrow or bed.	Time required to run through furrow or bed or into check.	Kind of soil.
				Gallons per minute.	Minutes.	
			Feet.			
89	Bed	104 feet	12.0	235	9	A.
90	do	150 feet	13.0	800		A.
91	do	100 feet	10.0	300	5	A.
92	do	100-300 feet	13.0	900	4-20	A.
93	do	100-200 feet	15.0	385	5-9	A.
96	do	150 feet	12.0	500	2-3	A.
98	Furrow	300 feet	7.0			A.
98	Check	0.25-5 acres				A.
101	do	To 10 acres				A.
105	Tablet	600-900 feet	50.0			
106	do	To 1,200 feet	65.0			
107	do	720 feet	30.0			
108	do	300 feet	25.0			S.
108	Furrow	600 feet	4.0	350	15	S.
109	do	150-300 feet	3.5	150	28	B. W.
110	Tablet	To 1,200 feet	44.0			B. W.
110. 75	do	300 feet	36.0			B. L.
112	do	150-300 feet	53.0			B. L.
112	Bed	80 feet	30.0	1,000	15	B. L.
114	Furrow	60 feet				B. L.
116	do	60-150 feet				B. S.
117	do	150-300 feet	4.0	210	5	B. S.
118	do	30-40 feet	1.0	75		S.
119	do	30-50 feet	1.0			S.
120	do	100 feet	1.5	60		S.
122	do	150 feet	1.5		8	B. S.
123	do	225 feet	1.5			B. S.
124	do	130 feet	1.5	10		B. S.
124	do	400 feet			300	B. S.
126	do	200-400 feet	3.0		30	B. S.
128	do	400 feet			300	S.
129	do	350-500 feet			120-300	B. S.
130	do	150-1,550 feet	3.5	35		B. S.
131	do	150 feet	1.3	4	90	S.
131	do	150 feet		16	60	S.
132	do	200 feet		8	180	S.
134	do	330 feet			15	S.
136	do	150 feet		8	40	B. W.
137	do	200-300 feet		7	45	L.
140	do	90-800 feet				
142	Bed	210 feet	21.0			S.
144	do	200 feet	10.0			S.
145	Furrow	210 feet	12.0			S.
146	do	125 feet	1.2	22	3	S.
146	Bed	60 feet	30.0			S.

Experiments made by the United States Department of Agriculture to determine the amount of water used by the various systems of irrigation show that the furrow system required considerable less water than flooding the land, and that irrigation by means of deep furrows required less water than irrigation by means of shallow furrows. In some soils the system of flooding can not be used to advantage owing to the baking of the ground. If the ground is of such consistency as to bake when dry, the furrow system should be used. The advantages of the furrow system for the irrigation of a crop over systems of flooding are that it requires less water and that it leaves the soil in much better condition. The finely pulverized top layer of soil is a great benefit in assisting vegetation and in keeping out the intense heat of the sun. In many places in Texas more cultivation and less irrigation would produce very beneficial results.

## DUTY OF WATER.

The quantity of water used for irrigation varies widely in different parts of the country. Where it is abundant there is a natural tendency to use it to excess; where it is scarce the reverse is found to be the case. Results of tests made to determine the depth of water used in irrigation for a limited number of cases have shown that between 1 and 8 inches were used per irrigation. Where the higher limit was used the ground became exceedingly boggy, and crops were probably damaged by the excess of water. Among truck farmers it is common to irrigate once in 7 to once in 14 days in the driest weather. Ten days will represent a fair average of opinion in the matter. Where land is irrigated so often it will of course require considerably less water per irrigation than in cases where irrigations are far apart. The quantity of water required for irrigation, which was commonly measured by the depth to which the water would cover the land were it evenly spread out, depends upon so many factors—such as the frequency of irrigation, condition of the soil, kind of soil, seepage losses in ditches, and, last but not least, the irrigator himself, that it is not easy to arrive at definite conclusions with regard to the same.

The following table gives the averages from the tables showing for the various crops the frequency of irrigation, the number of irrigations per season, the depth of water applied per irrigation, and the depth per season:

*Duty of water in southern Texas.*

Crop.	Frequency of irrigation.	Irrigations per season.	Depth of water per irrigation.	Depth of water per season.
	Days.		Inches.	
Alfalfa .....	38	9	5.1	5.72
Cane .....	13	5	3.6	2.50
Corn .....	16	3	4.4	1.53
Cotton .....	21	3	5.5	1.80
Johnson grass .....	37	7	6.1	3.51
Onions .....	a 11	11	2.4	2.40
Rice .....				5.12
Sorghum .....	13	4	3.5	1.86
Truck .....	12	6	2.8	1.30
Average for all crops .....			4.2	2.67

\* Irrigated less frequently early in the season than later; the average is given.

It will be noticed that the figures in the last column of the table are not calculated from those in the other columns, but are computed independently. The figures showing the depths per irrigation are averages of all statements showing this, while those showing depths per season are averages of all statements from which the total for the season can be computed. These averages naturally include different plants, and hence will not check.

Expressing the duty of water in the flow required per acre, rather than in depth of water received by the land, the statements from the plants reported on give the following averages:

*Rate of water supply per acre.*

Area irrigated .....	acres..	25, 030. 50
Rate of supply .....	gallons per minute..	303, 320. 00
Corresponding rate of supply per acre .....	do.....	12. 10
Straight average rate of supply .....	do.....	16. 40
Average depth of irrigation .....	feet..	2. 67
Average irrigation factor <sup>a</sup> .....	per cent..	15. 10

**LABOR AND COST OF IRRIGATING.**

The following table gives averages made from the data secured relating to the labor required for irrigation and its cost:

Cost of labor per day .....	\$0. 59
Labor per irrigation per acre .....	days.. .42
Cost per irrigation per acre .....	\$0. 31
Labor for irrigation per acre per year .....	days.. 3. 07
Cost for irrigation per acre per year .....	\$1. 96

**CROP RETURNS.**

The following table shows the average crop returns per acre:

	Unit.	Crop yields.	Assumed value per unit.	Value of crop per acre.
Alfalfa .....	Ton .....	5. 9	\$15. 00	\$88. 50
Corn .....	Bushel .....	41. 0	.50	20. 50
Cotton .....	Bale .....	8	50. 00	40. 00
Johnson grass .....	Ton .....	3. 0	12. 00	36. 00
Onions .....	Pound .....	18, 612. 0	.02	372. 24
Rice .....	do .....	2, 140. 0	.02	42. 80
Sorghum .....	Ton .....	4. 0		

**ONION CULTURE.**

While only a small percentage of the area reported upon is devoted to onions, the last table shows that this crop yields by far the largest returns of any grown. This fact and the great interest taken in onion culture in certain sections led to the collection of information as to onion culture. The following tables give the returns secured by six persons who were irrigating onions and the expenses incurred in raising the crops.

<sup>a</sup> Ratio of the given depth to the depth to which the land would have been covered by the given volume flowing continuously for one year.



*Returns of onion crop.*

Area.	Gross yield.	Gross returns.	Yield per acre.	Returns per acre.
<i>Acres.</i>	<i>Pounds.</i>		<i>Pounds.</i>	
75	1,462,500	\$25,000	19,500	\$341.33
6	120,000	2,500	20,000	416.67
40	1,200,000	26,000	30,000	650.00
13	455,000	9,000	34,300	662.30
20	500,000	12,200	25,000	610.00
13	223,000	3,349	17,154	257.62
167	3,960,500	78,649	23,716	470.95

Approximately 500 acres were planted in onions, the average yield reported being 20,497 pounds per acre, giving a gross yield of 10,000,000 pounds in the year 1904.

The following table shows the average cost per acre of raising onions, as well as the gross and net returns:

*Cost of raising onions.*

	Per acre.
Plowing and harrowing.....	\$2.00
Laying off beds or furrows.....	2.00
Eleven cultivations.....	5.00
Transplanting.....	16.36
Harvesting.....	12.95
Fertilizer.....	15.87
Irrigation water.....	25.55
Labor for irrigating 11 times.....	3.41
<b>Total</b> .....	<b>83.14</b>
Interest on investment in land, 7 per cent on \$30.....	2.10
<b>Total</b> .....	<b>85.24</b>
Returns: 20,497 pounds at 2 cents per pound.....	409.94
Expenses.....	85.24
<b>Profit</b> .....	<b>324.70</b>

The cost of irrigation water is considerably higher than it should be, owing largely to the fact that the pumping stations installed are considerably larger than required for the areas irrigated, and the fixed charges of plants are correspondingly high.

**RESERVOIRS.**

Many artificial reservoirs built of earth are in use in irrigation in Texas. Some of them are supplied with water by windmills, while others derive their supply from pumped and artesian wells. In most of this work considerable care has been taken in construction, and as a rule tanks of this nature have been fairly successful. There are, however, several instances where the soil was unfavorable and the construction poor, where difficulty has been experienced in making

reservoirs water-tight. The usual method of construction is to plow down to the clay under the bank of the reservoir to make a tight joint and then tamp the bank thoroughly during construction by the teams making a circle of the reservoir after having dumped their loads of dirt. Sometimes a layer of clay is placed on the inside bank of the reservoir, and in other instances dirt alone is used in the formation of the banks. Some of the reservoir banks are constructed of black, waxy soil having suitable consistency without the addition of clay to answer all the requirements. Should the clay be used in reservoir embankments the best place in which to put it is the center of the bank, where it will be protected from the air and where there would be no danger of cracking. A thorough joint should be made between the embankment of the reservoir and the ground itself. If the ground is of such nature that it would not hold water a trench should be dug to the nearest impervious stratum and a proper joint made there with the bank. In some of the reservoirs where trouble has been experienced in making them water-tight this has been remedied by puddling, by driving stock around inside while the soil is wet. One large reservoir with clay stratum below the ground appeared to be on porous ground and water went through it like a sieve. After tamping and puddling, however, no difficulty was experienced in making it water-tight. In many of the reservoirs of Texas borrow pits for the banks have been made on the inside. As it is impossible to empty these by gravity they are frequently stocked with fish.

Near Beeville, where the soil is largely of a sandy consistency, some difficulty has been experienced in making the reservoirs hold water. Some of the reservoirs have been lined with a coating of tar to make them water-tight. A description of the method of mixing the lining is given under the head "Beeville" (p. 404).

Most of the reservoirs in use in the region investigated have been constructed with a slope of 1 to 2 or 1 to  $1\frac{1}{2}$  inside and outside. This, in many cases, is too steep for the slope on the inside of the reservoir. This eventually results in the caving of the banks, which finally assume a more gradual incline. The proper slope to give the bank of a reservoir depends largely upon the material of which the banks are constructed as well as on the wave action on the sides. As a rule 1 to 3 on the inside and 1 to 2 on the outside will give suitable proportions. Where reservoirs are of any extent the banks should be protected against the action of waves. The usual method of protection is the use of riprap, laid on about 10 inches in thickness, made of assorted sizes of rough stone.

Contracts for reservoir construction are commonly let by the cubic yard of earth handled, the average cost of most of the reservoirs

being 10 cents per yard, most of the earth being obtained near by, necessitating only short hauls. In the computations following, 10 cents per cubic yard will be assumed as the cost of all such work, though with high embankments and longer hauls the cost will increase; but for embankments up to 10 feet there should be no material increase in cost of construction. The earth or clay for embankments is usually plowed and then handled by drag scrapers.

Reservoir capacity with reference to the size of a given plant may be conveniently reckoned in terms of the number of hours the total flow from the supply of water will require to fill the reservoir. The total area irrigated by the aid of artificial reservoirs is in the neighborhood of 2,000 acres. One of the most important factors in improving the irrigation facilities of the country and utilizing its resources to the fullest extent is the judicious use of reservoirs. Natural reservoir sites are few and often inconveniently located. In much of the country in Texas, on the other hand, artificial reservoirs may be built entirely in embankment wherever desired, provided the subsoil is suitable for retaining water. These reservoirs could be used for the storage of artesian well water, river water supplied by gravity, or pumped water. A study of the use made of artesian well water indicates that of the wells which are used for irrigation only about 20 per cent of the total available water supply is actually utilized, the remainder going to waste, although under present conditions the wells themselves may have reached their practical limit of irrigation. In other words, throughout a great part of the year well water not desired for irrigation will go to waste. Artesian wells will be subject to a certain annual expense which will represent the cost of the total amount of water furnished by them, and which will be taken at 12 per cent of first cost for all wells, made up of 7 per cent for interest and taxes and 5 per cent for depreciation and repairs, the latter to include all possible costs in connection with the wells, such as sand pumping, etc., as well as the elements of depreciation of wells due to deterioration of casing and to the supply falling off, owing to increased number of neighboring wells. The annual cost of the well is independent of the amount of water obtained from it. Thus, if only one-fifth of the well's supply is used the water per unit of volume will be five times as expensive as if the entire supply were used. While large sums of money have been expended for artesian wells, little has been done in the way of utilizing the resources of these wells to anything like their fullest extent.

The construction of reservoirs in general is a thing which should not be gone into in a haphazard manner. The conditions of the case should be carefully studied from the standpoints of rainfall, evaporation, seepage, time and amount of the water supply, and time and duration of the irrigation season. One very obvious method of

increasing the use of well water is by means of diversified farming, by planting crops requiring water at different periods of the year, instead of attempting to raise one crop only which will require irrigation for a brief period.

Throughout Texas there are many districts where at certain seasons of the year large amounts of water run to waste, while at other seasons the rivers run practically dry. In most localities no natural reservoir sites are obtainable, and to store the water would necessitate the construction of entire artificial reservoirs, as well as the installation of pumping plants to raise the water sufficiently to flow into the reservoirs. A study of the possibilities of reservoir construction indicates that such a water supply may be turned to the greatest practical advantage at a cost for irrigation water considerably below present figures for pumping, and that lands hitherto without an available water supply may experience the beneficial effect of irrigation.

A summary of the reservoir data shows a gross capacity of 123 acre-feet for 35 reservoirs, the total cost of construction being \$9,033. These reservoirs aided in the irrigation of 1,704 acres. The average cost of reservoirs per acre-foot was \$73.

In consideration of the use of reservoirs with artesian wells it should be borne in mind that artesian pressure will raise the water in the well without flow a certain height above the ground level, known as the static head. It is this head which is effective in creating pressure, causing the flow of water. Should the static head be large, a few feet additional pressure against the well will not have a great effect upon the discharge, but should it be comparatively small the additional pressure of a few feet of water would materially affect the output.

The pipe supplying the reservoir should therefore not be taken over the top of the reservoir bank, as is commonly done; it should be taken into the reservoir through the bank at the lowest point, in order that the maximum pressure operating against artesian flow may be as small as possible while the reservoir is filling up. If the static head of the well is very low an outlet should be provided from the well directly into the ditch used for irrigation, and a valve should be placed between the well and the reservoir in order that when the well is discharging into the ditch it may not have to supply water against the additional head caused by the water in the reservoir. Also, a separate discharge should be provided from the reservoir itself. This would necessitate at least three valves. Where piping is taken through the bank into the reservoir care should be taken to so design the connections that it will not be necessary to disturb this piping in any way to get at any of the valves or at the well itself. For this reason the pipe entering the reservoir should be provided with a flange connection. Any tend-

ency to disturb the pipe where it passes through the reservoir bank is liable to start a leak, resulting in much trouble. The piping leading from the wells should be arranged in such a manner that the interior of the well would be easily accessible. For this purpose a vertical T with the plug in the top end or else removable-flange connections should be provided in order to allow access to the inside of the well should it be necessary to sand-pump the same. Precautions should always be taken against malicious or thoughtless people throwing things down the well. In some of the wells which the writer saw, the top of the casing was provided with an elbow connected with horizontal pipe which went through the reservoir bank, all joints being screw joints, no flange couplings being used. Were it ever desired to get at these wells it would be impossible to do so without disturbing the earth around the pipe which enters the reservoir. This method of construction should by all means be avoided.

#### ARTESIAN WELLS.

The following table gives information as to the cost and capacity of and area irrigated by various artesian wells in Texas:

##### *Cost of artesian wells in Texas.*

Average cost per gallon per minute (straight average)----	\$21. 62
Average cost per gallon per minute for irrigation wells <sup>a</sup> (weighted average)-----	\$8. 30
Area irrigated -----acres--	1, 406
Average cost per acre irrigated (straight average)-----	\$71. 00
Average cost per acre irrigated (weighted average)-----	\$57. 77
Annual cost per acre irrigated-----	\$8. 63
Average cost per acre-foot-----	\$2. 86

In order to simplify the work of calculation it has been assumed that the wells to certain depths cost a certain amount per foot and that deeper wells cost a certain additional amount per foot of total depth, which varies for each additional 100 feet. This method is not very accurate, but as the figures are only approximate and the cost of boring is liable to vary considerably for different wells of the same depth, the figures may be regarded as sufficiently accurate for practical purposes. The following approximate assumptions have been made in figuring the cost of boring 6-inch wells:

King and Kenedy ranches:	
\$1.00 per foot to	900 feet.
1.10 per foot to	1,000 feet.
1.20 per foot to	1,100 feet.

---

<sup>a</sup> Wells delivering 7,618 gallons per minute cost \$63,272.

**King and Kenedy ranches—Continued.**

- \$1.30 per foot to 1,200 feet.
- 1.40 per foot to 1,300 feet.
- 1.50 per foot to 1,400 feet.
- 1.60 per foot to 1,500 feet.

**Around Carrizo Springs:**

- \$1.00 per foot to 400 feet.
- 1.10 per foot to 500 feet.
- 1.20 per foot to 600 feet.
- 1.30 per foot to 700 feet.
- 1.40 per foot to 800 feet.
- 1.50 per foot to 900 feet.
- 1.60 per foot to 1,000 feet.

The following summary shows the cost of irrigation and the irrigation factors of a few artesian wells in the vicinity of Carrizo Springs:

*Cost of irrigation.*

No.	Cost of well—		Annual cost per acre.	Irrigation factor.
	Per gallon per minute.	Per acre-foot used.		
122...	\$5.77	\$1.06	\$2.71	<i>Per cent.</i> 40.6
124...	5.54	4.01	3.73	10.3
125...	2.85	1.17	1.48	18.2
130...	3.96	1.74	.68	16.9
134...	-----	-----	-----	12.3
136...	11.62	5.08	7.64	17.0
137...	15.00	4.09	4.91	27.3
<b>Total</b> ....	44.73	17.16	21.10	142.6
<b>Average.</b>	7.46	2.86	3.52	20.4

**PUMPED WELLS.**

The following summary gives information on the cost and output of pumped wells. These have been rated at the cost per gallon per minute rate of pumping. It should be borne in mind that, provided the well capacity is not exceeded, this cost is dependent upon the capacity of the pump installed and is not fixed, as is the case with artesian wells.

*Cost of pumped wells.*

Average cost per gallon per minute (straight average)-----	\$6.13
Average cost per gallon per minute (weighted average)-----	\$2.75
Area irrigated-----acres..	934
Cost per acre irrigated (straight average)-----	\$15.25
Cost per acre irrigated (weighted average)-----	\$14.79

It will be noted that the cost per gallon per minute is considerably less than the corresponding cost for artesian wells, being practically one-third as great. To this must be added the cost of pumping machinery to make a comparison.

The average cost of pumping plants as shown by the report is as follows.

*Cost of pumping plants.*

Description.	Assumed cost.	Area irrigated.	Number of plants.	Average cost per acre irrigated.	
				Straight.	Weighted.
Steam plants:		<i>Acres.</i>			
Wood .....	\$100,940	9,790.5	26	\$79.32	\$11.23
Coal .....	18,800	855.0	6	90.75	19.05
Oil .....	85,300	5,100.0	2	15.00	16.73
Electric plants .....	3,000	400.0	1	7.50	7.50
Gasoline plants .....	19,140	483.5	21	109.40	39.69
Total .....	234,180	16,629.0	56	88.24	14.12

From the above tables the following comparative statement is made up:

*Comparative cost of artesian and pumped wells.*

	Straight.	Weighted.
Average cost of pumped wells and machinery per acre irrigated.....	\$103.49	\$28.91
Average cost of artesian wells per acre irrigated.....	71.00	57.77

The wide difference between the straight and weighted averages of the cost of pumping plants is caused by the extremely high cost for some of the small pumping plants. One plant, watering but 4.5 acres, cost \$778 per acre, while the largest plant included watered 6,000 acres, at a cost of \$6 per acre—0.77 of 1 per cent as much as the small plant.

**PUMPING PLANTS.**

The following table summarizes the data on the apparatus installed and the capacity of the various pumping stations, as well as the irrigation factors. The capacity of the pumps, in gallons per minute per acre irrigated, is calculated from the total capacity and the area actually under irrigation. The irrigation factor was calculated by dividing the total hours run per year by 8,760, the number of hours in a year. The investment in pumping plants was approximately \$310,000.

*Capacity of pumping plants.*

Area irrigated .....	acres..	17,190.0
Gross capacity of boilers.....	horsepower..	5,732.0
Steam engines.....	total horsepower..	4,227.0
Gasoline engines .....	do.....	181.0
Water motors .....	do.....	225.0
Electric motors .....	do.....	100.0
Steam engines.....	number of plants..	31.0
Gasoline engines .....	do.....	28.0
Water motors .....	do.....	1.0
Electric motors .....	do.....	1.0
Steam engines.....	average horsepower..	136.0
Gasoline engines .....	do.....	6.0
Water motors .....	do.....	225.0
Electric motors.....	do.....	100.0

Gross capacity of pumps.....gallons per minute..	265,992.0
Average pump capacity.....do.....	3,640.0
Average pump capacity per acre (straight average), gal- lons per minute.....	21.4
Average pump capacity per acre (weighted average), gal- lons per minute.....	14.3
Average daily run.....hours..	15.0
Average irrigation factor.....per cent..	14.0

The following table gives data on capacity, lift, and water horsepower of various plants, as well as the cost of fuel consumption per water horsepower. The water horsepower is calculated by dividing the product of the capacity in gallons per minute and lift in feet by 3,960 and making no allowance for losses of head in the piping.

*Consumption of fuel per water horsepower.*

Fuel.	Average lift.	Water horse-power.		Consumption of fuel per water-horsepower-hour.	Cost of fuel.	Cost of fuel per water-horsepower-hour.
		Gross.	Average.			
<b>Steam:</b>	<i>Feet.</i>					
Wood.....	36	868	28.4	0.01852 cord.....	\$1.46 per cord.....	\$0.027
Coal.....	54	297	39.1	39.60000 pounds.....	1.58 per ton.....	.031
Oil.....	45	1,034	517.0	.02420 barrel.....	.82 per barrel.....	.020
<b>Total.....</b>	<b>40</b>	<b>2,199</b>	<b>50.0</b>			
Water.....	42	100	98.8	2.22000 horsepower-hours.....	.0075 per horse-power-hour.....	.017
Electricity.....	46	52	52.3	.50000 gallon.....	.1580 per gallon.....	.088
Gasoline.....	64	60	2.1			
<b>Total.....</b>	<b>50</b>	<b>2,411</b>	<b>32.6</b>			

It will be noted that the cost of wood, coal, and oil was particularly low, but gasoline, on the contrary, is necessarily an expensive fuel. A very large saving could be made in the operation of gasoline plants by the use of distillate, which is nearly as efficient as gasoline. However, this is an article which is scarcely known throughout Texas, though quite commonly used in California.

Based on the figures given in the fuel table in the column "Number of B. T. U.'s per pound" (p. 366), the following are the weights of the various kinds of fuel required to generate 1 horsepower-hour provided the efficiency were 100 per cent:

*Heat value of fuels.*

[Pound per horsepower-hour.]

<b>Coal:</b>	
McAlester.....	0.186
Lehigh.....	.214
Eagle Pass.....	.247
Rockdale.....	.411
Lytle.....	.530
Carr.....	.369
Laredo.....	.300
<b>Oil.....</b>	<b>.133</b>
<b>Wood.....</b>	<b>.565</b>



Allowing 310 pounds of oil per barrel would require under the same conditions 0.000430 barrel per horsepower-hour. Allowing 3,500 pounds of wood per cord would correspondingly require 0.000161 cord of wood per horsepower-hour.

The losses of efficiency in a pumping plant may be segregated in the following manner:

- (1) Losses in the boiler and piping.
- (2) Losses in the cylinder of the steam engine, due to condensation, etc.
- (3) Losses in the mechanical efficiency of the engine.
- (4) Losses in the belting and pump.
- (5) Losses in the piping.

The most important loss of heat is one which it is theoretically impossible to avoid, but which may be reduced by increasing the pressure of steam supplied to the engine by superheating or by the use of condensers. The following table gives the theoretical efficiency and steam consumption in pounds per hour for various pressures of steam supplied to the engine, taken from Peabody's *Thermodynamics of the Steam Engine*:

*Efficiency and consumption of a perfect steam engine operating on the Carnot cycle.*

Initial pressure by the gauge above the atmosphere.	Condensing engines.		Noncondensing engines.	
	Efficiency.	Pounds of steam per horsepower-hour.	Efficiency.	Pounds of steam per horsepower-hour.
15	0.189	14.3	0.063	50.9
30	.215	12.8	.064	32.8
60	.248	11.4	.124	22.9
100	.278	10.5	.157	18.4
150	.302	9.8	.186	16.0
200	.320	9.5	.207	14.6
300	.347	9.0	.238	13.1

The theoretical figures can, of course, never be attained, but serve merely as a standard of comparison for the actual results. The following figures may be taken to represent approximately average conditions which should obtain in pumping plants installed in Texas, consisting of noncondensing steam engine driving centrifugal pump:

*Efficiencies of elements of pumping plants.*

	Per cent.
Boiler efficiency -----	65.0
Theoretical efficiency of a perfect noncondensing engine at 100 pounds gauge pressure -----	15.7
Efficiency of engine cylinder -----	55.0
Mechanical efficiency of engine -----	85.0
Pump efficiency -----	55.0
Efficiency of piping -----	95.0

The product of these efficiencies would give the combined efficiency of plant, representing the ratio of the actual work performed in lifting the water to the number of units of work available in the corresponding quantity of coal consumed, which in this case would be 2.5 per cent. On the basis of the theoretical quantity of fuel required per horsepower-hour the following efficiencies have been calculated for the plants in Texas:

*Efficiencies of pumping plants.*

Description.	Fuel efficiency.	Description.	Fuel efficiency.
<b>Wood:</b>	<i>Per cent.</i>	<b>Wood—Continued.</b>	<i>Per cent.</i>
No. 2.....	1.5	No. 116.....	2.5
No. 3.....	2.9	No. 117.....	2.0
No. 4.....	2.1	No. 118.....	.6
No. 5.....	1.7	No. 119.....	.5
No. 10.....	.9	Total.....	47.9
No. 11.....	.3	Average.....	1.5
No. 11.....	.2	<b>Oil:</b>	
No. 11.....	.5	No. 6.....	1.0
No. 30.....	.5	No. 16.....	14.2
No. 35.....	1.2	Total.....	15.2
No. 37.....	1.3	Average.....	7.6
No. 38.....	3.7	<b>Coal:</b>	
No. 84.....	1.8	No. 21.....	1.9
No. 88.....	4.1	No. 30.....	.8
No. 93.....	1.6	No. 34.....	2.1
No. 95.....	1.3	No. 85.....	2.1
No. 97.....	1.4	No. 87.....	1.7
No. 98.....	1.0	No. 90.....	.6
No. 101.....	3.5	No. 92.....	.9
No. 101.....	3.0	No. 93.....	.3
No. 102.....	.7	Total.....	10.4
No. 103.....	1.4	Average.....	1.3
No. 106.....	.9	Total.....	73.5
No. 110.50.....	1.2	Average.....	1.8
No. 110.75.....	1.7		
No. 111.....	1.1		
No. 114.....	1.0		
No. 115.....	.8		

In a certain large pumping station, designed with great care to give the highest efficiency, the fuel consumption was only 1.25 pounds of coal per water-horsepower-hour output, corresponding to a combined efficiency of 15 per cent.

### PUMPING.

#### METHOD OF ARRIVING AT COST.

In figuring the cost of irrigation, particularly in the case of pumping plants, it is a very common mistake to neglect entirely all allowance for interest on the investment, depreciation of the plant, repairs, renewals, and sometimes labor, fuel expense being regarded as the sole expense of operation. As a consequence the results obtained may be far from the true state of affairs. The cost for pumping water may be subdivided into three classifications: (1) Interest on the investment and depreciation of the plant; (2) operating expenses, repairs, and renewals, and (3) fuel expense.

The interest is of course independent of the time of operation, and the depreciation of the plant is also to a large extent independent of

the same, while the operating expenses may be considered in one sense dependent solely on the time of operation of the pumps. But this is not strictly true, since it is often impossible to engage labor on these terms owing to variations in weather, and the employer must often pay the engineer his full time. In small plants it is not uncommon to find the engineers employed on other work on the farm when the pumps are not running. This applies particularly to cases where the operation of the plants is not continuous over a long period of time.

Repairs and renewals are partly dependent on the length of time of operation. Depreciation, repairs, and renewals are commonly figured as a percentage of the first cost of the plant. In steam plants fuel expense, while depending mainly on the time of operation and the load, is nevertheless dependent also upon the number of times the plant is started and stopped. If the steam is allowed to go down between the stopping and starting of the plant it is commonly assumed that it will require two hours' fuel supply at full load to get up steam in starting.

In considering the percentage values of first cost which ought to be assigned to the various quantities making up the cost of pumping, circumstances and care of apparatus, of course, have a material effect. Seven per cent may be considered as a fair value to allow for interest and taxes on the entire plant; depreciation will vary from 2 to 30 per cent, depending upon the apparatus, its use and abuse; 8 to 10 per cent should be sufficient to represent depreciation of pumping plants if reasonable care is used; 2 per cent should be sufficient to cover depreciation of iron pipe; repairs and renewals commonly require 2 to 20 per cent of the original investment. Allowing 7 per cent for interest and taxes, 10 per cent for depreciation and 3 per cent for repairs and renewals gives a total of 20 per cent per annum of the original cost to be allowed for these items. With any sort of proper supervision this should be on the safe side for power-house work, though of course this will not allow for accidents which may occur through carelessness. Irrigation plants, particularly the small ones, are usually subject to quite heavy deterioration. They are generally poorly set up, exposed to dust and dirt getting into the working parts of the engines from insufficient housing, and as a result the real cost of pumping is higher than it should be. The annual fixed charges of pumping plants have been figured at 20 per cent on the pumping-plant investment, and 12 per cent on the remainder of the investment, such as pipe line, reservoir, and wells.

In the following table the cost of power is segregated under the heads of fuel expense, labor expense, and fixed charges per water-horsepower-hour. The amount of power required for raising 1 acre-foot of water 1 foot is 1.37 horsepower-hours, hence the column

representing this quantity in the table is easily obtained from the preceding column of "Total cost per water-horsepower-hour." The cost per acre-foot is obtained by multiplying the preceding column by the total lift and the cost per acre irrigated by multiplying the cost per acre-foot by the average annual depth of irrigation. The last column in the table gives the pump investment per acre irrigated. The results given are the straight averages of the results for the several plants.

Average cost of pumping water.

	Cost per water-horsepower-hour.				Cost per foot, acre-foot.	Cost per acre-foot.	Cost per acre irrigated.	Investment per acre.
	Fuel.	Labor.	Fixed charges.	Total.				
<b>Steam:</b>	<i>Cents.</i>	<i>Cents.</i>	<i>Cents.</i>	<i>Cents.</i>	<i>Cents.</i>			
Wood.....	2.76	1.24	12.93	17.45	23.91	\$10.71	\$16.83	\$74.00
Coal.....	2.97	.49	10.89	14.16	19.41	11.56	18.44	91.00
Oil.....	.76	.17	1.08	2.50	3.42	1.56	5.75	15.00
<b>Average.....</b>	<b>2.71</b>	<b>1.04</b>	<b>1.57</b>	<b>8.95</b>	<b>21.60</b>	<b>10.27</b>	<b>16.40</b>	<b>73.00</b>
<b>Electricity.....</b>	<b>1.68</b>	<b>.32</b>	<b>.56</b>	<b>2.56</b>	<b>3.51</b>	<b>1.61</b>	<b>6.83</b>	<b>8.00</b>
<b>Gasoline.....</b>	<b>8.65</b>	<b>.03</b>	<b>14.46</b>	<b>22.20</b>	<b>30.45</b>	<b>18.40</b>	<b>28.90</b>	<b>109.00</b>
<b>Average.....</b>	<b>4.85</b>	<b>.60</b>	<b>12.72</b>	<b>17.25</b>	<b>23.66</b>	<b>12.38</b>	<b>19.75</b>	<b>85.00</b>

The cost of gasoline plants per unit of water pumped is far in excess of the cost of other plants. This is due mainly to the small size of the gasoline plants, since naturally the relative cost of small units is considerably higher than that of large units.

The following table gives the total annual water-horsepower-hours as well as the segregated and total annual expense for various plants. The table is classified according to fuels. Wood-burning plants are further classified under the heads of rice-irrigation plants and plants used in irrigating other crops. Gasoline plant No. 9 is also used for rice irrigation.

Total cost of pumping water.

	Area irrigated.	Annual water-horsepower-hours.	Total annual cost.			
			Fuel.	Labor.	Fixed charges.	Total.
<b>Wood for fuel:</b>	<i>Acres.</i>					
Rice.....	7,461.0	817,685	\$9,283	\$4,633	\$10,916	\$24,832
Other crops.....	1,423.5	449,664	5,801	1,815	9,524	17,140
<b>Total.....</b>	<b>8,883.5</b>	<b>1,267,349</b>	<b>15,084</b>	<b>6,448</b>	<b>20,440</b>	<b>41,972</b>
<b>Gasoline for fuel.....</b>	<b>311.0</b>	<b>28,630</b>	<b>1,535</b>	<b>53</b>	<b>3,844</b>	<b>4,432</b>
<b>Coal for fuel.....</b>	<b>855.0</b>	<b>253,025</b>	<b>3,683</b>	<b>1,049</b>	<b>4,962</b>	<b>9,724</b>
<b>Oil for fuel.....</b>	<b>5,100.0</b>	<b>1,428,400</b>	<b>16,386</b>	<b>2,521</b>	<b>17,060</b>	<b>35,977</b>
<b>Electricity.....</b>	<b>400.0</b>	<b>108,700</b>	<b>1,792</b>	<b>342</b>	<b>600</b>	<b>2,734</b>
<b>Total for steam plants<sup>a</sup>.....</b>	<b>14,838.5</b>	<b>2,950,774</b>	<b>35,163</b>	<b>10,018</b>	<b>42,492</b>	<b>87,673</b>
<b>Rice.....</b>	<b>12,610.0</b>	<b>2,254,015</b>	<b>28,075</b>	<b>7,154</b>	<b>28,244</b>	<b>61,473</b>
<b>Other crops.....</b>	<b>2,589.5</b>	<b>724,789</b>	<b>10,023</b>	<b>2,917</b>	<b>18,082</b>	<b>31,632</b>
<b>Total.....</b>	<b>15,199.5</b>	<b>2,978,804</b>	<b>38,098</b>	<b>10,071</b>	<b>46,336</b>	<b>93,105</b>

<sup>a</sup> The totals here do not include the items "Gasoline for fuel" and "Electricity."

From this summary the following summary of segregated and total charges per acre irrigated and per water-horsepower-hour is

obtained. This summary gives the weighted averages and is to be contrasted with the summary on page 507, which is obtained by averaging the results for the various plants.

*Cost of pumping per acre and per water-horsepower-hour.*

	Annual cost per acre irrigated.				Cost per water-horsepower-hour.				Cost per acre-foot raised 1 foot.
	Fuel.	Labor.	Fixed charges.	Total.	Fuel.	Labor.	Fixed charges.	Total.	
Wood for fuel:					<i>Cents.</i>	<i>Cents.</i>	<i>Cents.</i>	<i>Cents.</i>	<i>Cents.</i>
Rice.....	\$1.25	\$1.62	\$1.47	\$3.34	1.14	0.57	1.33	3.04	4.17
Other crops.....	4.08	1.27	6.69	12.04	1.29	.40	2.12	3.81	5.22
Total.....	1.70	.73	2.30	4.73	1.19	.51	1.61	3.31	4.53
Gasoline for fuel.....	4.93	.13	12.36	17.46	5.48	.19	13.73	19.40	26.00
Coal for fuel.....	4.31	1.23	5.84	11.38	1.44	.41	1.96	3.81	5.22
Oil for fuel.....	3.22	.49	3.35	7.06	1.15	.18	1.19	2.52	3.45
Electricity.....	4.50	.85	1.50	6.83	1.68	.32	1.56	2.56	3.51
For all steam plants.....	2.37	.67	2.87	5.91	1.19	.34	1.44	2.97	4.07
Total results:									
Rice.....	2.07	.56	2.24	4.87	1.16	.32	1.25	2.73	3.74
Other crops.....	4.10	1.13	6.98	12.21	1.46	.40	2.50	4.96	5.98
Total.....	2.41	.66	3.05	6.13	1.23	.34	1.56	3.13	4.29

It will be seen that the average cost of irrigation per acre per year lies between \$4.87 for rice-irrigation plants and \$12.21 for plants irrigating other crops, and between \$4.73 for wood-burning plants and \$17.46 for gasoline plants. The lowest cost of irrigation was under plant No. 101, and was \$2.19 per acre per year.

It is particularly to be noted that throughout the fixed charges are higher than charges for fuel, the total average fixed charges per acre irrigated being approximately equal to the sum of the charges for fuel and labor. In some cases the fixed charges make the cost of power far out of proportion to the other charges. It may perhaps be considered that in the column of fixed charges some allowance should be made for the small use made of some of the plants, but the deterioration can not by any means be considered as ceasing when the plant is not in operation; in fact, in many instances, owing to the rusting of the machinery, it would rather increase than decrease from disuse. A fixed charge of 20 per cent as assumed would then allow 7 per cent for interest, 3 per cent for repairs and renewals, and 10 per cent for depreciation, corresponding to a life for the plant of ten years. As shown on page 491, the average irrigation factor is but 14 per cent, indicating that the plants are used on an average only one-seventh of the time. In order to cut down the expense of irrigation the irrigation factor itself should be increased. This may be done in the following manner:

If a plant were designed for the irrigation of a certain crop requiring water only in May, June, and July, and demanding the maximum rate of flow continuously for these three months, the irrigation factor would be 25 per cent. If another crop were to require water in August, September, and October, under the same conditions the irrigation factor would also be 25 per cent. Were the maximum supply in the two cases to be the same, and were both crops watered from the

same pumping plant without storage, the irrigation factor would then be 50 per cent instead of 25 per cent. The only additional expense of water for the second crop would be for operation, the fixed expenses being practically not increased. The larger the fixed expense with reference to the operating expense the greater is the inducement for improvement in the irrigation factor by diversified farming.

Suppose, for example, an irrigation plant were installed for irrigating 50 acres of land at a first cost of \$2,500. Allowing 7 per cent for interest and 13 per cent for depreciation, repairs, etc., would make a total fixed cost per year of \$500. If fuel and labor for continuous operation of the plant three months in the year cost \$500 the annual cost of operation would be \$1,000, provided the plant were operated three months of the year. Provided, now, that it is required to irrigate an additional tract of land requiring the same quantity of water during three other months of the year, this would necessitate an additional expense of \$500, or a total expense of \$1,500 per year, and hence at an expense of \$15 per acre instead of \$20 per acre, which would have been the cost had the first tract alone been irrigated.

In general, two plans may be followed to increase the irrigation factor—(1) construction of reservoirs and (2) the use of water at different seasons. Of course if the dry season is of brief duration, say two or three months, it is possible that little may be done under the latter plan, but provided the dry season is uncertain and of long duration considerable may be done by judicious management and varied crops. Additional water may be furnished at nearly the cost of the additional operating expenses, and it is usually poor policy to let the plant lie idle part of the year when it should be bringing in revenue. This is perhaps largely caused by owners failing to appreciate the large fixed expense under which they operate.

In order to cut down the fixed charges it would appear that it is important to have a low first cost of plant, particularly where fuel is as cheap as in Texas. The greater part of the pumping is performed by means of centrifugal pumps, which are in general by far the cheapest part of the plant. It is the poorest kind of economy, however, to invest in a cheap pump of this nature, provided the cheapness is secured at the expense of efficiency, as the necessary increase of boiler and engine equipment would much more than make up for any saving which might be made in this manner, aside from increased fuel expense.

The cost of labor for operation of pumping plants is exceptionally low, and hence conditions are correspondingly favorable for economy in this direction. One of the main advantages of gasoline lies in the saving of labor, particularly in small plants. The cheapness of

labor, however, would indicate the inadvisability of installing gasoline plants of any capacity, if no cheaper form of the fuel, such as distillate, is available for use in gasoline engines.

One of the main savings in the use of fuel oil over other fuels lies in the greatly diminished labor of firing. This is a matter of importance in plants of considerable size only and is further minimized by the cheapness of labor.

The smaller irrigation plants in Texas, requiring up to about 20 horsepower, have usually been run by gasoline engines, and plants over this size by steam. In the majority of cases steam plants are equipped with steam engines, though a few of them have direct-acting steam pumps and others have pulsometers. While the use of the last two methods of pumping would involve probably a minimum in the way of initial expense and have the advantage of simplicity of operation, their use is not generally to be recommended on account of the high steam consumption. Were compound steam pumps to be used, considerably better economy could be obtained than with pumps not compounded, but these have so far not found their way into the field. The majority of the steam engines for plants of 20 to 100 horsepower are of the throttling variety and consequently do not make efficient use of the steam. Where fuel is as cheap as it is in many parts of Texas it is true that simplicity may count for quite a little in the operation of the plant, considering the kind of labor which is usually employed for the same; still, automatic engines in plants of any size should justify the additional expense in the saving of fuel.

By far the greater proportion of the steam pipes leading from the boilers to the engines have no covering and the loss by condensation is considerable. As an approximation, it may be said that 80 square feet of exposed steam-radiating surface demand 1 boiler horsepower. A little extra care and money spent in installation of plants would be amply repaid. In all the territory covered there is only one irrigation pumping plant of any size in which due consideration appears to have been given to economy of operation. This is the plant of Ross Clark. It is the only plant which has water-tube boilers, compound condensing engines which condense, and centrifugal pump directly connected to the engine. Direct connection is here made by a rigid coupling.

In order to direct-connect machinery with a rigid coupling the foundation must be particularly good, as otherwise it would be better to use a flexible coupling to avoid possible strains from the shafts getting out of line. Direct-connected units do away with loss in belting, usually 5 to 10 per cent, besides saving considerable space. It requires, however, a proper combination of pump and engine to be effective.

The automatic engines are to be preferred to throttling engines on the ground of efficiency, although more expensive to install. Few of the stations use condensers, and in the majority of places where they were used not over 16-inch vacuum was obtained, indicating either poor design or operation of the plants. In many of the pumping stations some simple form of gravity or jet condenser could be used for condensing the steam in the engine which would probably increase considerably the efficiency of the plant.

Single-acting deep-well pumps, 2.5 to 6 inches in diameter, with a stroke of 15 to 20 inches, are used extensively. These are driven by a power head as a general thing, though occasionally they are driven by means of a walking beam. The efficiency of this type of pump with a lift of 60 to 70 feet will usually be between 40 and 50 per cent, and although not high, they are usually the most efficient pumps that can be used in the conditions under which they operate, namely, a small quantity of water and a high lift, considered together with the fact that no pit is necessary to bring the pump nearer the water, the pump being inserted in the well. It is a common fallacy to assume that the lift is dependent upon the position of the bottom of the suction pipe attached to the pump cylinder. Of course this is not the case, as the lift is measured from the surface of the water standing in the well on the outside of the suction pipe.

In the case of most wells operated by deep-well pumps the pump cylinder and casing usually fit the well so closely that it is extremely difficult, if not impossible, to measure the actual distance of the level of the well water below the ground, particularly when the well is being pumped. Should there be room between the well casing and the pump cylinder for the insertion of a small pipe the water level may be determined very accurately by means of the method which the writer has used. A one-eighth-inch pipe will answer very well the requirements of the case. By blowing down the pipe it is a very simple matter to tell instantly when the surface of the water in the well has been reached, as the concussion of the air bubbles emerging from the end of the pipe under water will give very definite indication thereof. Knowing the length of the pipe, the distance to standing water in the well is easily obtained. In one well which was tested by this means the water level seemed quite indeterminate, varying perceptibly. However, by observation it was ascertained that this variation was due to the unequal flow naturally occasioned by the pump, the level being highest just before the pump started to deliver water on the upstroke.

In figuring the lift of well water allowance has been made in the wells, which were not measured, for the probable distance which the water would be drawn down, based on the rather limited information which could be obtained on this subject.



There are two sources of loss in pumping plants—(1) on entrance to the piping and (2) on discharge from the end of the pipe—which could easily be greatly reduced by suitable design. While in many cases these losses are small and negligible, in others, particularly with low-head plants, they are liable to represent a considerable percentage consumption of energy, which should by all means be reduced, since this can be done very simply and cheaply. The energy of water discharged from the end of a pipe varies with the square of the velocity of discharge, and a velocity of 8 feet per second is represented by the energy required to lift the quantity discharged 1 foot higher than necessary. A taper joint of gradually increasing section will largely overcome the loss of head in discharge. Since the discharge varies with the fourth power of the diameter, by increasing the diameter of the pipe 42 per cent the discharge would be reduced to one-fourth of its previous value, and by doubling the diameter would be reduced to one-sixteenth of its previous value. At the entrance to a straight pipe projecting into a body of water there is a loss of energy equivalent to one-half of the velocity head in the pipe itself. This can be easily avoided by bellng the pipe at entrance. A bell-shaped entrance is preferable to a cone-shaped, though the latter will often be a decided improvement over a straight pipe. It is no uncommon sight to find discharge pipes throughout Texas throwing water into the air considerably higher than the level of the discharged water, owing to the high velocity head in the piping. It is obvious to even a casual observer that this represents a considerable loss of power.

#### PRACTICAL POINTS ON INCREASED EFFICIENCY OF PLANTS.

Deep-well pumping plants are sometimes provided with stuffing boxes near the ground level, in order to force the water to a few feet greater elevation. It is not uncommon for a large amount of power to be consumed in the stuffing boxes, due to either the pump rod being bent or to the gland being screwed down too tightly. In fact, if gasoline engines are used for operation, it is not difficult to put such a load on the engine by screwing down the gland as to bring the engine to a standstill. With intelligent care stuffing boxes should cause no trouble, but as commonly operated in such plants, if the stuffing box leaks the operator will simply screw the gland tighter until the leak has been stopped. In order to prevent leaks in stuffing boxes the packing should be taken out at least once a week and oiled and coated with graphite. Packing to be effective should retain its elasticity, and if in that condition it would require only light pressure from the gland to prevent leakage. Stuffing boxes can be avoided in most cases by the use of a walking beam connected with the pump and by running the continuation of the discharge pipe to a sufficient

height. Where apparatus will not receive due attention this is to be preferred for obvious reasons.

With deep-well pumps all the work is commonly on the upstroke. This necessitates larger engines and means more wear and tear on machinery than if the power required were equally divided between the up and down strokes. When a walking beam is used, by properly adjusting the weight on the end away from the pump, work on the two halves of the stroke can be very nearly equalized. The sound of the machinery operating furnishes the best clue to the amount of weight which is best to use. A long, strong spring can be used if desired on deep-well pumps without a walking beam, the spring being attached directly to the pump rod and being put under considerable initial tension; but this would be generally more expensive than a walking beam.

But little attention is commonly paid to the leakage from deep-well pumps until the leakage has become very bad. The leather pump cups are frequently left in so long that they become badly worn and allow very large leakage of water, thus materially reducing the output of the pump. The leakage may be judged by the speed at which water sinks in the well pipe when the pump is at rest. In several windmill plants visited, the pumps when operated at slow speed delivered no water, owing to undue leakage. While many kinds of machinery will run without attention, to obtain the best results they should always be kept in good condition and should receive frequent overhauling.

When a gasoline engine is operating at full load it will, as usually constructed, have an explosion every other stroke. The percentage of load may be judged approximately by the ratio of the total number of explosions to the total possible number of explosions per minute, which can be counted without difficulty. This would be more accurate by deducting from each the explosions per minute required to run the motor unloaded. Gasoline engines require a certain mixture of air and gasoline in the cylinder to obtain the best results from the fuel. If the mixture is too strong or too weak the best results can not be obtained. Thus by allowing too great a flow of gasoline to the engine a large amount of fuel may be wasted. The proper mixture of gasoline and air will depend in part on the quality of gasoline used. Most gasoline engines are provided with a small needle valve for regulating the flow of gasoline, with two positions marked—one for the gasoline supply for starting and the other for operation. By not setting this valve to the right point considerable gasoline may be wasted. In general, it is well to throttle the supply of gasoline to a point where the rate of explosion starts to increase or the speed to fall off. Losses due to improper setting of this valve may be very large. In California distillate has been used directly

in the engine cylinders in place of gasoline, thus reducing greatly the cost of operating plants.

The following tables give detailed information regarding artesian wells and pumped wells in southern Texas:

*Location and description of artesian wells in southern Texas.*

Location.	Number of wells.	Name of well.	Kind of well.	Rated flow.	Measured flow.	Size of well.	Depth of well.	Head of well above ground.	Water strata.
				Gal- lons per min- ute.	Gal- lons per min- ute.	In.	Feet.	Feet.	
Inez	1		Open bottom	10			222		
Do	1		do	50			179		
Do	1		do	30			705		
Do	1		do	10			180		
Do	1		do	10			425		
Do	1		do	60			127		
Do	1		do	60			114		
Do	1		do	20			50		
Do	1		do	9			127		
Do	1		do	30			148		
Do	1		do	8			17		
Do	1		do	30			202		
Do	1		do	20		2	330		
Do	1		do	9		2	50		
Do	1		do	30		2	327		
Do	1		do	150		12	900		
Do	1		do	30		5	880	28	
Port Lavaca	1		Strainer	62		7	900		Sand.
Do	1		do	173		7	950		Do.
Do	1		do	173		10	1,100		Do.
Do	1		do	35		7	900		Do.
Victoria	1			100			1,032		
San Antonio	1		Open bottom	700		10	1,020	11	Caverns.
Do	4		do			8	880	35	Do.
Do	5		do		{ 4,170 each }	12	880	35	Do.
Do	1		do					57	Do.
Do	1		do		{ 1,080 +60 }	12	700	17	Do.
Do	1		do	800		10	640	17	Do.
Do	1		do		6	6	1,500	15	Do.
Do	1		do		45	6	1,474	16	Lime rock.
Do	1		do	300		6	1,200	20	Caverns.
Do	1		do	200		4	884	20	Do.
Santa Gertrudas	1	Santa Gertrudas	Strainer		81	5 $\frac{1}{2}$	565		Sand.
Do	1	Kingsville	do		113				Do.
Lapara	1	Paistle I	do		250	5 $\frac{1}{2}$	700		Do.
Do	1	Miffin	do	180		6 $\frac{1}{2}$	740		Do.
Do	1	Esperanza	do	a 230		6 $\frac{1}{2}$	740		Do.
Do	1	Bariosa	do	a 240		6 $\frac{1}{2}$	700		Do.
Do	1	Serpa	do		307	6 $\frac{1}{2}$	617		Do.
Do	1	Turcott	do	a 300		6 $\frac{1}{2}$	737		Do.
Do	1	Alegos	do		212	5 $\frac{1}{2}$	865		Do.
Katherine	1	Katherine		60		6 $\frac{1}{2}$	730		Do.
Do	1	Comal		100		3	82 $\frac{1}{2}$		Do.
Do	1	Marana		20		2 $\frac{1}{2}$	500		Do.
Do	1	St Thomas		60		6 $\frac{1}{2}$	730		Do.
El Sauz	1	El Sauz	Strainer		127	5 $\frac{1}{2}$	1,462		Do.
Do	1	Rosita		a 170		5 $\frac{1}{2}$	1,100		Do.
Do	1	Rudolf		340		5 $\frac{1}{2}$	940		Do.
Do	1	Saltillo	Strainer	a 75			900		Do.
Do	1	Noria	do	a 175		4 $\frac{1}{2}$	900		Do.
Falfurrias	1		Open bottom		80	5 $\frac{1}{2}$			Do.
Do	2			a 80					Do.
25 miles south of Falfurrias	2				{ 73 54 }	5 $\frac{1}{2}$			
Carrizo Springs	1		Open bottom	200		5 $\frac{1}{2}$	600		Sand rock.
Do	1		do	192		5 $\frac{1}{2}$	640		Do.
Do	1		do	1,400		12	720		Do.

a Estimated.

Location and description of artesian wells in southern Texas—Continued.

Location.	Number of wells.	Name of well.	Kind of well.	Rated flow.		Measured flow.	Size of well.	Depth of well.	Head of well above ground.	Water strata.
				Gal- lons per min- ute.	Gal- lons per min- ute.					
Carrizo Springs	2		{ Open bottom	120			In. 5½	Feet. 800	Feet. 40	Sand rock.
Do	1		{ do	120			8	662	40	
Do	1		{ do	150			5½	380		Do.
Do	3		{ do			b 230	6			Do.
Do	1		{ do			b 100	6	400		
Do	2		{ do	15			8	490		Do.
Do	2		{ do	25			4½	365	19	Do.
Do	2		{ do				6	417	19	Do.
Do	2		{ Open bottom			a 234	6	650	77	Do.
Do	1		{ do			a 300	12	650	77	Do.
Do	1		{ do	a 125			8	640		Do.
Do	1		{ do				10	640		Do.
Do	1		{ do			b 50	5½	332		Do.
Do	2		{ do			b 103		400		Do.
Do	1		{ do	a 65			6½	380		Do.
Do	2		{ do	a 33			5½	384		Do.
Do	2		{ do	a 33			5½	384		Do.
Do	2		{ do	80			6½	550		Do.
Do	2		{ do				6½	420		Do.
Do	2		{ Open bottom	30			5½	636		Do.
Do	1		{ do	60			4	406		Do.
Do	1		{ do	300			4½	449	12	Do.
Do	2		{ do	175			6	380		Do.

a Estimated.

b Calculated.

Location and cost of artesian wells in southern Texas.

Location.	Casing.		Cost per foot.		Total cost.	Cost per gallon per minute.	Area irrigated.	Estimated irrigated area.	Cost per acre irrigated.	Cost per acre well is estimated to irrigate.	Annual cost per acre irrigated.
	Length.	Di- ame- ter.	Bor- ing.	Cas- ing.							
Inez	Feet. 300	In. 12						Acres.			
Do	380	9									
Do	210	6									
Do	515	5									
Do	385	2									
Port Lavaca					\$8,300.00	\$101.50					
Do					6,650.00	38.45					
Do					11,000.00	63.65					
Do					6,300.00	180.00					
Victoria											
San Antonio	854	10	\$4.20	\$1.80	5,394.00	7.72	35.0		\$154.00	\$269.70	\$19.48
Do	650	8	2.50	1.00	3,250.00						
Do	650	12	5.30	1.70	5,770.00	1.38					
Do							18.5	100			
Do					10,000.00	8.78	180.0	500	55.56	20.00	6.88
Do	1,500	6	2.50	.75	4,875.00	6.10	50.0	90	97.50	54.17	11.70
Do		6			4,000.00	89.00	50.0		80.00		9.60
Do		6	2.50	.75	3,900.00	13.00	25.0	30	156.00	130.00	19.72
Do		4½			3,500.00	17.50	21.0		166.67		20.00
Santa Gertrudas			1.00		985.00	12.25					
Do			1.00								
Lapara	200	5½	1.00	.78							
Do	500	4½		.64	1,176.00	4.70					
Do	371	6½		1.00							
Do	386	5½	1.00	.78	1,475.00	8.20					
Do	60	4½		.64							

Location and cost of artesian wells in southern Texas—Continued.

Location.	Casing.		Cost per foot.		Total cost.	Cost per gallon per minute.	Area irrigated.	Estimated irrigable area.	Cost per acre irrigated.	Cost per acre well is estimated to irrigate.	Annual cost per acre irrigated.
	Length.	Diameter.	Boring.	Casing.							
	Feet.	In.					Acres.	Acres.			
Lapara.....	840	6 <sup>1</sup> / <sub>2</sub>		\$1.00	\$1,418.00	\$5.46					
Do.....	385	5 <sup>3</sup> / <sub>8</sub>		.78							
Do.....	60	4 <sup>1</sup> / <sub>2</sub>		.64							
Do.....	411	6 <sup>1</sup> / <sub>2</sub>		1.00							
Do.....	225	5 <sup>3</sup> / <sub>8</sub>	1.00	.78	1,388.00	5.76					
Do.....	160	4 <sup>1</sup> / <sub>2</sub>		.64							
Do.....	60	6 <sup>1</sup> / <sub>2</sub>		1.00							
Do.....	460	5 <sup>3</sup> / <sub>8</sub>	1.00	.78	1,251.00	4.08					
Do.....	180	4 <sup>1</sup> / <sub>2</sub>		.64							
Do.....	425	6 <sup>1</sup> / <sub>2</sub>		1.00							
Do.....	247	5 <sup>3</sup> / <sub>8</sub>	1.00	.78	1,555.00	5.18					
Do.....	248	4 <sup>1</sup> / <sub>2</sub>		.64							
Do.....	560	5 <sup>3</sup> / <sub>8</sub>		.78							
Do.....	700	4 <sup>1</sup> / <sub>2</sub>	1.10	.64	1,561.00	7.37					
Do.....	100	3 <sup>1</sup> / <sub>2</sub>		.53							
Katherine.....	500	6 <sup>1</sup> / <sub>2</sub>	1.00	.96	1,357.00	22.60					
Do.....	230	4 <sup>1</sup> / <sub>2</sub>		.64							
Do.....	500	6 <sup>1</sup> / <sub>2</sub>	1.00	.96	1,357.00	22.60					
Do.....	230	4 <sup>1</sup> / <sub>2</sub>		.64							
El Sauz.....	800	5 <sup>3</sup> / <sub>8</sub>	1.60	.78	3,477.00	27.36					
Do.....	600	4 <sup>1</sup> / <sub>2</sub>		.64							
Do.....	Start	5 <sup>3</sup> / <sub>8</sub>	1.30	.78	2,000.00	11.75					
Do.....	End 60	2 <sup>1</sup> / <sub>2</sub>		.38							
Do.....	Start	6 <sup>1</sup> / <sub>2</sub>	1.20	1.00	1,900.00	5.60					
Do.....	End 300	4 <sup>1</sup> / <sub>2</sub>		.64							
Do.....	End 300	3 <sup>1</sup> / <sub>2</sub>	1.20	.50	1,655.00						
Do.....	900	4 <sup>1</sup> / <sub>2</sub>		.64							
Carrizo Springs.....	Start	5 <sup>1</sup> / <sub>2</sub>		.89			23.5	50			
Do.....	End	4 <sup>1</sup> / <sub>2</sub>		.67			50.0	50	\$22.14	\$22.14	\$2.66
Do.....	48	5 <sup>3</sup> / <sub>8</sub>	1.67	.78	1,107.00	5.77	30.0				
Do.....	(a)	10		1.00							
Do.....	90	5 <sup>1</sup> / <sub>2</sub>		.85	686.00	5.56	43.0	60	31.90	22.14	3.82
Do.....	60	5 <sup>1</sup> / <sub>2</sub>	1.00	.81	662.00	5.51	35.0		12.30		1.48
Do.....	86	6	1.00	.90							
Do.....	20	6	1.00	.90	1,312.00	3.97	100.0	200	18.12	6.51	1.57
Do.....	20	6	1.00	.90							
Do.....				1.10	600.00	15.00	7.0		85.71		10.28
Do.....	55	4 <sup>1</sup> / <sub>2</sub>	1.00	.69	408.00	28.85		30		30.73	
Do.....	65	6	1.10	.90	518.00	20.70					
Do.....	90	6	1.30	.90	926.00	3.95	400.0				
Do.....				2.04							
Do.....											
Do.....	35	10		1.56							
Do.....											
Do.....											
Do.....											
Do.....											
Do.....			1.00		384.00	11.62					
Do.....			1.00		384.00	11.62					
Do.....			1.10		1,200.00	15.00					
Do.....											
Do.....											
Do.....											
Do.....											
Do.....	165	4 <sup>1</sup> / <sub>2</sub>	1.00	.60	548.00	1.83	48.0		11.41		1.37
Do.....							100.0				

a To first water stratum.

Location and description of pumped wells used for irrigation in southern Texas.

Location.	Number of wells.	Distance water drawn down by pumping.	Kind of well.	Rated flow.	Measured flow.	Size of well.	Depth of well.	Distance from ground to standing water.	Water strata.
Victoria	2	24	Strainer	Gals. per minute. 600	Gals. per minute. 12	In. 12	Feet. 100	Feet. 36	Sand and gravel.
Do	1	24	do	500	700	12	90	36	Do.
Do	1	5		70		11 1/2	115	54	Sand.
Inez	3	33		a 300		8	230	25	Do.
				a 150		8			
				a 300		8	270	17	Do.
San Antonio	2		Open bottom.	80		8	713		Lime rock.
Do	1				.800		705		Do.
Do	2		Open bottom.	15		6	1,000	76	Do.
Do	1	45	do	35		6	860	145	Do.
Do	1	31	do		2,417	12	1,005	2	Do.
Do	1	35	do	45	438	6	980	2	Do.
Beeville	1		do			5 3/8	100	65	Porous rock.
Do	1	(b)	do		37	5 3/8	175	40	
Do	1		do			6 1/2	90		
Do	1		do			8	60	35	Gravel.
Do	1		do	.28		5 3/8	59	24	Sand.
Do	1		do			6	160	44	
Do	1		do			5 3/8	100	45	
Do	1		Dug			7 1/2	80		
Do	1		Open bottom.		5	5 3/8	93	50	
Do	1	64	do		234	6 1/2	225	40	Sand.
Uvalde	3	(d)	do	1,000		6	100	33	Gravel.
Moore	2	20	do	50		5 1/2	100	36	Sand rock.
Do	1		do	80		5 1/2	100	45	Do.
Pearsall	1		do	80		6	105	38	Do.
Do	2		do	125		6	108		Do.
Do	1		do	45		5 3/8	240	60	Do.
Do	2		do	110		8	121	46	Do.
Do	2		do			6 1/2	201	46	
Do	2		do	120		10	200	40	Do.
Do	2		do			8			
Devine	1		do	46		8	110		

a Estimated.

b Six inches per gallon per minute.

c Square.

d Slightly.

*Location and cost of pumped wells used for irrigation in southern Texas.*

Location.	Casing.		Cost per foot.		Total cost.	Cost per gallon per minute.	Area irrigated.	Estimated irrigable area.	Cost per acre irrigated.	Cost per acre well is estimated to irrigate.	Time required to fill reservoir.
	Length	Diameter.	Boring.	Casing.							
	Feet.	In.					Acres.	Acres.			Hours.
Victoria							20.0				76
Do.							50.0				
Inez							200.0	200			
San Antonio	500	8	\$3.25	\$1.00	\$2,815	\$35.20					
Do.							86.0				
Do.	45	12	3.30	1.70	4,500	1.86	350.0		\$12.88		
Do.	850	10									
Do.	970	6	2.01	.75	2,700	6.22	120.0	200	22.50	\$13.50	
Beeville	175	5 1/2	.50	.60	193	5.20	20.0		9.65		
Do.	40	6 1/2	.50	.80	77		10.0		7.70		
Do.	60	6	.50	.75	75	2.50	7.0		10.71		
Do.	53	5 1/2	.55	.60	64	2.29					
Do.					70	14.00	4.0				
Uvalde	180	6									
Do.	40	20									
Moore	44	5 1/2	.50	.70	81	1.62	9.0		18.00		
Do.	44	5 1/2									
Pearsall			.50		50	.87	4.0		12.25		
Do.	12	6	.50	.75	62		6.0		20.83		
Do.	12	6	.50	.75	63		6.0				
Do.	216	5 1/2	.50	.60	250	5.55	8.5		29.40		
Do.	6	8	.70	1.00	91						
Do.	6	6 1/2	.50	.85	108	1.79	23.0		8.61		

\* Feet square.

*Investment per acre irrigated by pumping plants in southern Texas.*

	Cost of pumping plants.	Total investment.	Area irrigated.	Investment per acre.	
				Pumping plant.	Total.
Steam:			Acres.		
Wood	\$109,940.00	\$119,125.00	9,790.5	\$11.21	\$12.18
Coal	18,800.00	30,500.00	855.0	19.67	35.70
Oil	85,900.00	85,900.00	5,100.0	16.72	16.72
Total	212,040.00	234,925.00	15,745.5	13.47	14.92
Electricity	3,000.00	3,000.00	400.0	7.50	7.50
Gasoline	18,290.00	31,530.00	483.5	37.90	65.20
Total	233,330.00	269,455.00	16,629.0	14.00	16.20

*Investment per water horsepower pumping plants in southern Texas.*

	Cost of pumping plant.	Total investment.	Water horsepower.	Investment per water horsepower.	
				Pumping plant.	Total.
Steam:					
Wood	\$117,690.00	\$126,875.00	807.70	\$146.00	\$157.00
Coal	18,800.00	32,500.00	206.36	91.00	158.00
Oil	85,900.00	85,900.00	1,084.00	83.00	83.00
Total	221,790.00	244,675.00	2,048.06	106.00	119.00
Electricity	3,000.00	3,000.00	52.30	57.00	57.00
Gasoline	21,455.00	35,815.00	56.12	382.00	638.00
Total	246,245.00	283,490.00	2,156.48	114.00	132.00

*Annual expenses of pumping water, using different kinds of fuel.*

WOOD.

Area irrigated.	Annual water-horse-power hours.	Annual expenses.			
		Fuel.	Labor.	Fixed charges.	Total.
<i>Acres.</i>					
180.0	60,000	\$1,273	\$150	\$466	\$1,889
350.0	120,000	1,000	625	618	2,243
280.0	52,000	593	218	728	1,539
406.0	106,700	768	683	890	2,251
64.0	4,860	128	107	200	435
200.0	9,650	676	200	302	1,178
	4,825	676	200	301	1,177
	9,650	450	200	301	951
6,000.0	450,000	3,720	2,250	7,200	13,170
7,480.0	817,685	9,283	4,633	10,916	24,832
26.0	1,786	17	23	166	206
250.0	252,500	1,994	681	4,000	6,675
4.5	630	14	3	548	565
8.0	1,065	50	8	1,550	1,608
500.0	167,800	2,535	840	570	3,945
144.0	5,710	97	32	512	641
220.0	36,800	827	110	380	1,317
40.0	5,170	129	53	420	602
15.0	636	20	8	198	226
101.0	2,910	29	15	440	484
100.0	3,415	42	19	366	427
15.0	1,222	47	23	374	444
1,423.5	449,664	5,801	1,815	9,524	17,140

COAL.

120.0	56,600	1,278	196	1,140	2,616
300.0	62,700	507	238	880	1,625
350.0	122,400	1,366	563	1,296	3,255
40.0	7,060	270	25	418	713
25.0	4,425	112	14	440	566
20.0	1,820	120	11	818	949
855.0	255,025	3,683	1,049	4,992	9,724

OIL.

3,800.0	1,270,000	16,000	2,283	13,800	32,063
1,500.0	158,400	386	238	3,260	3,884
5,100.0	1,428,400	16,386	2,521	17,060	35,977

GASOLINE.

20.0	1,540	94	-----	197	291
50.0	7,930	396	-----	268	664
86.0	6,780	285	53	1,150	1,488
8.0	1,050	60	-----	170	230
20.0	1,330	126	-----	168	294
7.0	88	10	-----	100	110
6.0	1,390	100	-----	344	444
13.0	1,604	122	-----	404	526
13.0	1,640	80	-----	344	424
50.0	797	46	-----	120	166
9.0	1,428	103	-----	157	290
6.0	1,364	53	-----	212	265
23.0	1,127	60	-----	210	270
311.0	28,090	1,535	53	3,844	5,432

ELECTRICITY.

400.0	106,700	1,792	342	600	2,734
-------	---------	-------	-----	-----	-------



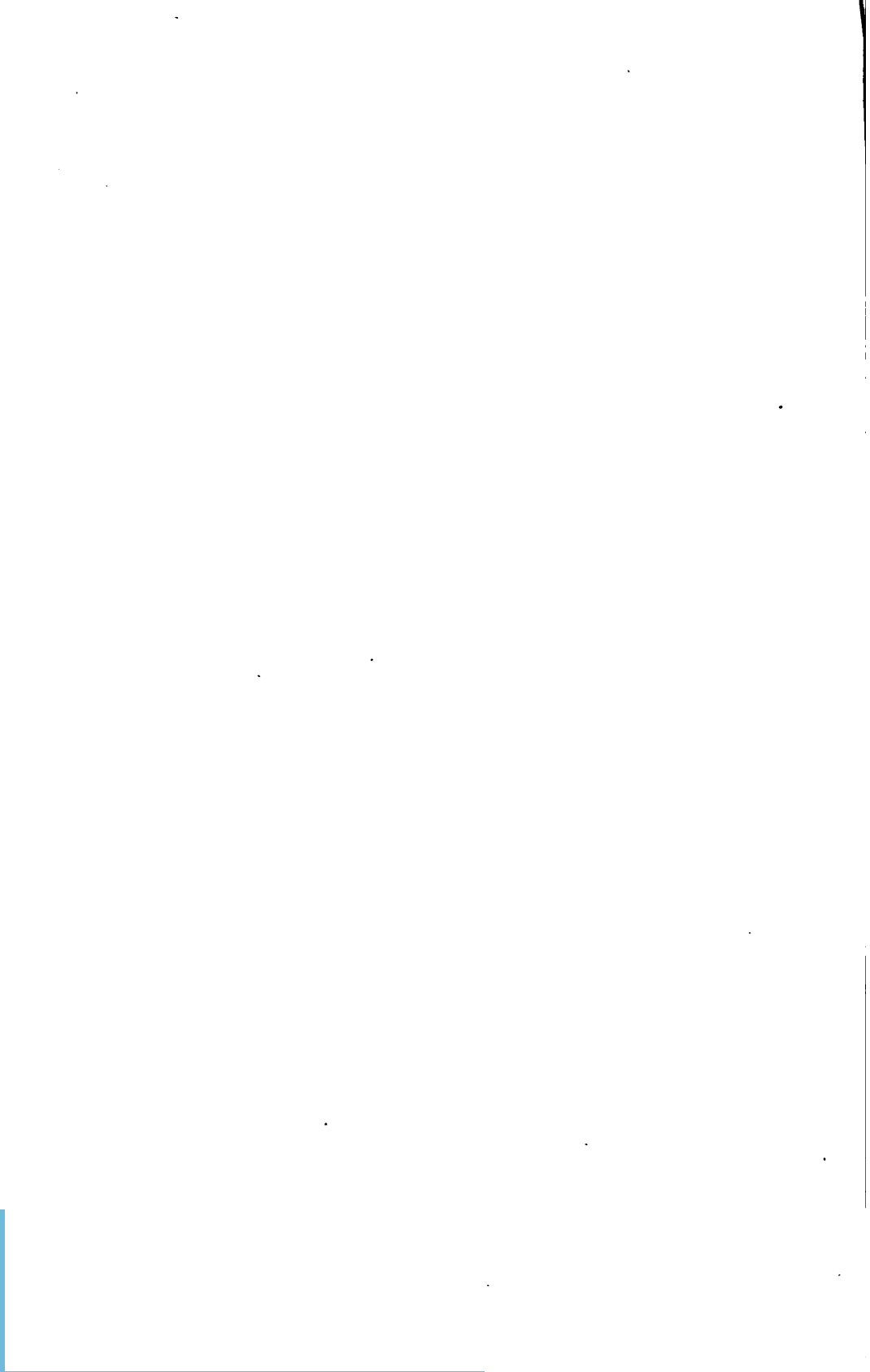

# RICE IRRIGATION IN LOUISIANA AND TEXAS IN 1903 AND 1904.

By W. B. GREGORY,

*Professor of Mechanical Engineering, Tulane University.*

## THE SEASON OF 1903.

The copious rains of the winter and spring and the tardiness of the warm weather were accountable for a delay in planting of from three to four weeks during the season of 1903. It was impossible to plow the ground at the usual time and the backwardness of the season made it undesirable to plant the rice as early as usual. A cold north wind, about the 1st of June, seemed to blast the tender leaves of the rice plants in some sections, causing fear of permanent injury to the early rice. The abnormally cool weather continued until about the middle of June, after which time the climatic conditions for the remainder of the season were almost ideal. The temperature was high and the air possessed considerable humidity; the frequent rains were distributed over the entire rice belt. Of course there were small sections in which the rainfall was not as plentiful and as well distributed as in others, but in general the rainfall was sufficient to produce Providence rice throughout the rice belt. However, the rainfall was not sufficiently great to cause the large pumping plants to close down; in fact, many of them reported an average season, so far as the amount of water pumped was concerned. But in cases where new pumping plants had been hastily erected and where trouble was experienced on that account enough rain fell to produce a good crop in many cases where, in average years, complete failure would have resulted.

There was no increase in the total acreage of the rice crop in Louisiana in 1903 over that of the preceding year. In the vicinity of Crowley there was a reduction in acreage variously estimated at from 20 to 25 per cent. This was partly due to the inability of farmers to prepare the land in time to finish seeding at a date early enough to promise a fair crop. Another cause was the fact that on land where rice had been raised for several years it had become evident that the soil needed a rest and that it would be unprofitable to continue planting the same fields in rice indefinitely. In Texas there was an increase in acreage due to the development of new territory; this increase was about 25 per cent over the acreage of the previous year.

The weather prevailing during the growing season, after the middle of June, when cold spring changed to warm summer, was, as has been said, very favorable to the rapid growth of the rice. The appearance of the crop was good, giving promise of a bountiful harvest. Dry weather prevailed from the beginning of harvest and long after the last of the rice had been thrashed and removed from the fields.

A belief was prevalent during the early days of the thrashing season that the yield of the entire crop would be above that of the average years, but as the thrashing was continued it became evident that the crop grown from late planting was yielding much less than that of the earlier planting. The best yields were obtained from fields planted before May 1. Good yields were obtained from seeding during the first half of May, while the yield from rice planted late in May and in June was not so good.

The quality of the crop was excellent and there was not as much red rice as usual. The early rice proved to be superior to the late in quality as well as quantity.

The spring of 1904 found nearly 1,000,000 pockets, 100,000,000 pounds, or nearly one-fifth of the total crop of 1903, in the various mills and warehouses of the rice country, because the owners were unwilling to sell at the prevailing low prices.

#### THE SEASON OF 1904.

The dry weather which prevailed during the harvesting season of 1903 extended into the winter months up to the time of preparation for a new crop. The situation was then relieved by sufficient rain to render the soil moist and in good condition to receive the seed throughout most of the rice country. Even in places where little rain had fallen there was some moisture in the soil. Much of the plowing had been finished by February 15, and two or three weeks later some early rice was sown.

While there was enough moisture in the soil to insure the germination of the seed, the rains had not been sufficient to affect the streams which are used for irrigation purposes. In the latter part of February salt water was reported in the Calcasieu River north of Lake Charles, a very unusual occurrence at any season of the year.

An opening had been made in the temporary structure of the Mermentau dam in August, 1903, to allow the navigation of the river. (See p. 520.) Before March 1, when the dam was closed by the permanent structure, the salt water had entered the lower river, and as the rainfall was very light there was no surface drainage to be carried off and consequently there was no current. The amount of salt water present in the lower river was great enough to cause some apprehension early in the season, and as soon as irrigation was begun

the pumps produced a backward flow. By the latter part of May there was a scarcity of water throughout the rice country, both in streams and wells.

The weather of the first two weeks of April was abnormally cool and had a bad effect on the early rice. During the latter part of April more or less abundant rain fell over nearly all the rice belt. The evaporation was high, due to the warm weather, and the soil was capable of absorbing a considerable quantity of water; as a result, the surface drainage which found its way into the irrigating streams was too small to have an appreciable effect in raising the level of these streams.

In the Mermentau country, when it had become evident that there was a possibility of trouble with the salt water, the owner of each pumping plant was desirous of getting as much of the fresh water as was possible before the salt invasion; besides, the rice needed much water. The effect of continued, universal pumping was to hasten the time when the water was too salty to be used in irrigating rice.

During the first week of June the condition of the crop in both Louisiana and Texas was fairly good. There was need of rain and some signs of distress in fields of young rice. At this time some of the plants along the Laccasine and the lower parts of the Mermentau were pumping brackish water; a similar state of affairs existed south of Beaumont on Taylors Bayou. The plant of the Abbeville Canal Company, taking water from Bayou Vermilion, was closed down because of salt water on June 21, and did not resume pumping until July 9. While pumping plants near Crowley were pumping a part of the time and the water was comparatively fresh, many of the plants farther down the river had ceased to pump. Near Lowry pumping was discontinued as early as June 13. The Lichtenstein & Hechinger plant, on Bayou Queue de Tortue, stopped pumping on June 27, when it became known that a sample of water taken the previous day contained 142 grains of salt per gallon.

About June 20 the rice country of Texas received abundant rains, and a week later there were plentiful rains in the Louisiana rice district. Well-distributed rains continued throughout the remainder of the irrigation season and into the harvesting time for the early rice. So much rain fell that the last ten days of June practically marked the end of the pumping season for most of the large plants, although they did a little desultory pumping after that time.

The rainfall was not only sufficient in many cases to supply the needs of the growing rice, but also soon raised the water in the rivers and bayous. Before these heavy rains occurred the Mermentau and its tributaries had had their water level considerably reduced, so much so that at times the water on the inside of the dam was 4 feet lower than mean-tide level.

Samples of water were taken on July 18 and 19 at various points on the Mermentau, including water from the Gulf side of the dam and as far upstream as the village of Mermentau. These samples were sent to Washington and analyses made by the Bureau of Chemistry of the United States Department of Agriculture.

It will be noted that this was after the rains had become general throughout that district. The stream had risen somewhat at this time. For instance, the Bayou Plaquemine, at the Miller-Morris plant, had risen about 1.5 feet above the lowest level recorded, which was during the last week of June. The samples obtained, therefore, in all probability do not exhibit the worst conditions of the season of 1904, but they show that the problem was serious and that the opportune rainfall was quite necessary to avert a calamity and save the late rice.

The principal salts that have an injurious effect on the rice crop are sodium chlorid, or common salt, magnesium chlorid, and potassium chlorid. The reports of analyses made of irrigation waters in this part of the country have usually been approximate, and all the chlorid has been computed as sodium chlorid and the amount contained given as so many grains per gallon of water analyzed. For the above reasons, and to render the results of general interest and in such form that the principal result will not be lost in too much detail, the complete results will not be given, and only the number of grains of the chlorids of sodium, magnesium, and potassium computed per gallon of water. As a matter of interest it may be said that the amount of magnesium chlorid varied from about 6.4 to 13 per cent of the total amount of the chlorids, and the potassium chlorid from about 1.7 to 2.7 per cent of the total amount.

The table given below shows the locality where the samples were taken and the amount of salts present. All samples were taken within 2 feet of the surface of the water. Previous analyses, made in 1902 by the Bureau of Chemistry, showed conclusively that the amount of salt is much greater in the deeper water.

*Salts in water taken from the Mermentau River July 18 and 19, 1904.*

	Grains per gallon.
Seaside of Mermentau dam.....	1, 167
Upper side of Mermentau dam.....	802
Center of Mud Lake.....	635
Lower end of Grand Lake.....	240
Center of Grand Lake.....	211
Upper end of Grand Lake.....	186
Halfway between Lowry and Houcks.....	175
Center of Lake Arthur.....	161
Mermentau River at mouth of Bayou Queue de Tortue.....	67
Bayou Queue de Tortue at Lightenstein & Hechinger plant..	132
Mermentau River at Mermentau, La.....	74

The effect of the rainfall and the resultant irregularity in the demand for water in different parts of the territory is shown by a comparison of the water taken from the Mermentau at the mouth of Bayou Queue de Tortue with that taken at the Lightenstein & Hechinger plant. The result given in the table is the mean of two samples, one taken at a depth of 6 feet and the other at a depth of 20 feet. For some reason the first sample showed a greater amount of salt than that taken at a greater depth. However, two samples taken August 13 showed a greater amount of salt at a lower depth. These samples were taken at depths of 6 and 21 feet and showed an average amount of only 7.5 grains of salt per gallon.

The harvest season was unusually early. Rain continued almost daily several weeks after harvesting was begun, causing considerable damage to the early crop, much of which was chalky or overripe and of a poor quality. By October 1 harvesting was reported more than half finished on the Gulf coast. Only a small amount of thrashing had been done up to this time, owing to the prevalence of local showers.

The rice harvested from the late planting was of a better quality than the early rice, as the climatic conditions for harvesting and thrashing were much improved later in the season. However, the crop of 1904 was inferior to that of 1903, both in quantity and quality, and this inferiority was not confined to the rice raised along streams where salt water had appeared. While undoubtedly there was some damage done by irrigation with salt water, even the so-called "river" rice, irrigated with water from the Mississippi, and also that of the Teche country, were in every way inferior to the previous crop. The climatic conditions up to October 1 were very unusual, in fact different from any yet experienced since the development of the rice industry in this section. Growing weather continued through September, the days and nights being warm and the daily rains supplying the moisture to keep the air well saturated. In some instances a second crop of rice was raised, an unheard-of experience previous to last year.

The effect of the moisture was to render the rice chalky, and to take away its milling qualities. The weather after October 1 was favorable to harvesting and thrashing, but the grain proved inferior, although an improvement on that gathered during the wet period. It seems to be an impossibility to have more than an average crop in any instance from late sowing.

The problem of disposing of the rice crop has been the cause of considerable advertising during the last two years. The Rice Kitchen at the Louisiana Purchase Exposition at St. Louis did much toward making rice extensively and favorably known as a food. Several

large concerns in the North and West have been retailing a fair grade of rice for 5 cents per pound, a price considerably below that usually charged.

A distributing company was organized at Crowley and began business on August 1. It controls several large rice mills, buys and sells on commission, and conducts a general warehousing business. Several sales of considerable magnitude have been made by this company in foreign countries.

The area planted to rice in Louisiana in 1904 was reported by the United States Department of Agriculture to be 376,500 acres, while that of Texas was 234,200 acres. The total area in the United States was 662,006 acres. The combined acreage of Louisiana and Texas is therefore 99.2 per cent of the total area.

### METHODS OF FARMING.

The broad low contour levee advocated in a previous publication on rice irrigation<sup>a</sup> has not been generally adopted; however, it is growing in favor, and was used to some extent in the vicinity of Crowley during the last two seasons. Its construction is more expensive and requires more time than the older form of levee. A road machine is needed for its construction, and many of the small farmers do not own one of these implements. The growing of rice, rather than weeds, on the levees is certainly desirable, as is the ability to drive all implements used in the cultivation of the land and in planting and harvesting the rice over the levees in any direction, instead of treating each "cut" as a separate field. The difference of level of the land within a "cut" is much less than that used in the early days of rice planting; 2.5 to 3 inches is commonly used now, while as much as 6 inches was not unusual a few years ago. The rays of the sun penetrate and warm shallow water, but have little effect with a depth of half a foot. Often the best rice in the field is raised on top of the broad levees, where the ground is wet but is not covered with water. In former times, when the difference of level between the highest and the lowest ground in a "cut" was half a foot, it was noticed that often the finest rice grew on the highest ground, which was sometimes covered with water and sometimes without water on its surface. Fresh water applied to a rice field two or three times in a season will give better results than when water is allowed to stand on the fields continuously throughout the irrigating season.

By the use of the broad levee the available area for rice is increased over the old method and the field is kept free from weeds. Levees of either class ought to be of sufficient height and strength to hold a reasonable amount of rainfall and so effect an economy of

---

<sup>a</sup> U. S. Dept. Agr., Office of Experiment Stations Bul. 113.

flood water. However, the downpours in some parts of the rice country during the seasons of 1903 and 1904 were so excessive that the depth of water on the fields would have been too great, even if the field was in need of irrigation at the time; in such a case part of the water must necessarily be wasted.

Water, as used in rice irrigation in Louisiana and Texas, not only supplies a necessary condition for the growth of the plant, but also contributes to the success of the rice crop by destroying the weeds. Rice is an aquatic plant and thrives in water, but too great a depth causes the stalks to "spindle" up, and later in the season to be more readily blown down by winds and storms. Excellent rice has been raised on ground that was not submerged, but merely moist, but to use this method generally would require some cultivation to get rid of the weeds. By the present system of culture the weeds are killed when the ground is flooded with water, as few of them are aquatic.

The cool weather of April, 1904, prevented the early rice from being flooded at the usual times, and when flooded the plants were attacked in many sections by a white worm about one-fourth to three-eighths of an inch in length and having a red head. These worms flourished best in grass-infested fields. To turn the water off and dry the land was an effective method of disposing of this pest, but in grassy fields turning the water off meant giving up the rice to the grass, while keeping it on the fields meant ruin from worms. About the time water was turned off of fields that had been planted early it became necessary to irrigate the late planting. At this time, as already noted, water was very low in streams and in wells, while evaporation was high. This condition gave the weeds and grass a chance at the late rice, which went through the experience of the early planting. The result was a thin stand in many instances. Of course, there were some fields which produced large yields.

The condition of the soil for late planting in 1904 was such that much rice was planted deeper than usual, and this resulted in slow growth. The lack of moisture was relieved in part by timely rains, which helped to save the stand.

During the season of 1904, crops in the rice country have been diversified more than ever before. This result was brought about, at least partially, by the low price of rice and the high price of cotton. Farmers have raised a large part of the supplies which they need, and in many instances have realized good returns on crops other than rice.

Cotton was planted in southwestern Louisiana in 1904 to a greater extent than in former years. In fact, up to a year or two ago cotton was looked upon as one of the impossible crops for that region. Good crops were reported in some instances, but in general the season was too wet for cotton. Another difficulty was found in the lack of drainage, the importance of which was often underestimated, and



which was rendered difficult by the fact that the rice land is nearly level and the amount of surface water large.

The poorer grades of rice are being used to feed stock, and it is claimed that this is the only way in which a value above the cost of production can be realized. Rice will undoubtedly continue to be the principal crop of the coast country, the cotton, corn, potatoes, and garden truck being incidental. These enable the farmers to become independent of the merchant and to live well without getting hopelessly in debt during years when the rice crop fails to fulfill expectations. There is a growing realization of the fact that it is a much better policy on the part of farmers to plant only the amount of rice that can be properly attended to rather than to sow more land than can be thoroughly prepared, watered, and harvested.

As a money crop, rice must be of good quality to be a success, as only the higher grades are profitable to raise at present prices. In the future greater care will be exercised in the selection of seed, in the preparation of the land, in applying water, and in every detail which will tend to produce a better grade of rice.

Much of the rice land of Texas, of recent development, is a black, waxy soil of great fertility. The cost of working this land is perhaps \$3 per acre more than the cost of working clay or clay-loam soils, but the increase in yield is sufficient to more than compensate the increased cost of production.

### THE WATERWEED.

A strange weed has appeared in the rice country of southwestern Louisiana and eastern Texas. It had been sufficiently distributed during the season of 1903 to attract attention and cause some apprehension, although it had been observed in the vicinity of Gueydan, La., about four years previous. This plant is popularly known as the "waterweed." Specimens sent to the United States Department of Agriculture at Washington were identified as *Pongatium zeylanicum*, a native of the tropics of South America, but rather widely distributed in the tropics of both hemispheres. The mature plant attains a height of from 4 to 6 feet. It has a hollow stalk about one-half inch in diameter, and its leaves are about 3 inches long and 1½ inches broad. The roots are large and spongy, showing the aquatic nature of the plant. Its growth is rapid. It is propagated entirely from the seeds, which are abundant and very minute, and which are doubtless distributed through the fields by the irrigating water, as the plant grows along canals and laterals as well as in the rice fields. Unlike most of the weeds with which the rice farmer has to contend, this weed is not killed by the flood water of the rice fields, but, on the contrary, flourishes in water.

Undoubtedly this pest was introduced through imported seed rice. As the weed has already proved a nuisance in localities where it is best known, seed rice should be carefully selected, especially in sections where the weed has not yet appeared. Seed production can be prevented by hand pulling where thinly distributed through the fields; on the levees the plants may be cut. Where the plant has become abundant, it may be necessary to resort to rotation of crops, planting some other crop which requires thorough cultivation instead of rice. It is absolutely necessary to destroy the plants on the levees and waterways before sufficiently advanced to mature seeds if the rice fields are to be protected from its invasion. Little attention was given to the eradication of this weed during the season of 1903 in parts of the rice country where it was observed for the first time, and its nature was almost unknown.

The waterweed appeared in the Crowley district during the latter part of June, 1904. It did not give serious trouble last year, as it was found that Honduras rice planted early got possession of the ground and was unaffected by the weed; Japan rice was not as successful in combating the pest.

While all weeds are undesirable, the waterweed will probably not prove a greater nuisance than many others.

#### **DRAINAGE. .**

The wet seasons of 1903 and 1904 have emphasized the need of good drainage for the rice fields, highways, etc. A fall of 1 inch in 100 feet gives good, quick drainage in removing the water from the rice fields. The drainage necessary for cotton and other crops has already been referred to. In some instances it has been found desirable, where the drainage outlet for a considerable area passes under a flume of the canal, to install a small pumping plant and return the drainage water to the canal.

Drainage projects of considerable magnitude are being considered for various parts of the lowlands of south Louisiana. One of the most important of these was organized three years ago and had for its object the reclamation of fourteen entire townships situated in the eighth ward of Vermilion Parish. The tract extends from Bayou Queue de Tortue on the north to the Gulf of Mexico on the south, embracing 280,000 acres of land, most of which has been unfit for cultivation, owing to its being partially submerged, but which when properly drained will be classed with the most productive in that part of the State.

The funds for this work have been provided by means of a 5-mill tax on all the property covered by the district, this tax enabling the district to issue bonds to the amount of \$60,000, which, it is estimated, will be sufficient to complete the work.

Thirty-eight miles of main canals will be cut, and as many laterals as may be required to thoroughly drain the land of the district. The work of dredging these canals was begun in May, 1903, and up to September, 1904, 17 miles had been completed, 9 of which lie south of Gueydan, leading toward Grand Lake, which is to be the southern outlet, and 8 miles in a northwesterly direction, with drainage into Bayou Queue de Tortue. Two dredging outfits are now constantly at work. The main canals average 20 feet in width at the bottom on the upper levels, and 40 feet at the outlet, near Grand Lake, the depth being from 3 to 4 feet. It is estimated that the main system of canals will be completed by April, 1905, and that the necessary laterals will be finished before the end of the year. Some of the land that has thus far been reclaimed is being broken for planting next year. Reclamation of similar lands in the near future by private enterprises will doubtless add to the area of tillable land in this section.

#### **EFFECT OF SALT WATER.**

Crops were raised in 1903 on land which had been liberally irrigated with salt water in 1901 and 1902. During these two years, where the salt water had been used on comparatively young rice the result was invariably disastrous, but where the rice was well advanced toward maturity the effect in many cases was hardly noticeable.

The heavy rains of the winter of 1902 and spring of 1903 did much toward washing the salt out of the soil. On many fields where the allowance of salt water for the two previous years had been liberal a good average crop was raised during the season of 1903, and the quality of the rice was excellent. The verdict among the rice farmers seems to be that no permanent injury to the soil has resulted from the salt water.

The experiences of 1901 and 1902 had taught farmers to be careful about irrigating with salt water. There was no trouble from this source in 1903, while in 1904 the condition looked extremely serious for rice farms irrigating from streams subject to salt invasion. Doubtless some damage was done by the salt water before July 1, after which time the plentiful rains relieved the situation.

At many of the large pumping plants a close watch was kept for salt water, and when it appeared pumping was stopped. In the lower Mermentau district there was probably too little water applied to the rice in some instances for this reason, but farther upstream, on account of opportune rains, there was very little harm done.

### THE MERMENTAU DAM.

The seasons of 1901 and 1902 were disastrous to the rice men who obtained from the Mermentau River and its tributaries water to irrigate their crops. The demand for water had become so great during those years that salt water flowed in from the Gulf of Mexico and was pumped into the canals and used on the rice land, doing great damage to the crop. It was determined by some of the leading rice men of that section that this should not be repeated in 1903. Accordingly the Rice Irrigation and Improvement Association of Crowley was formed. Mr. Miron Abbott was elected president and Mr. George H. Tinker secretary, and a thorough canvass was made of territory affected by going to each town of the entire district, holding meetings, and explaining the methods and plans to be employed to combat the salt water. The spirit of cooperation was sufficiently strong to insure the success of the scheme; however, as the subscriptions were entirely voluntary many who were to reap the benefits of the undertaking did not contribute. Funds for carrying on the work were solicited at the rate of 50 cents per acre irrigated.

The crop failure of the previous season and consequent financial depression caused some delay in starting, and it was not until April 13, 1903, that the board of directors felt justified in proceeding with the work. The first pile was driven on May 30.

The abundant rainfall during the winter and early spring of 1903 gave a supply of fresh water in the Mermentau and its tributaries which was much greater than that of an average year. Nevertheless, since the area of rice land using water from this source had increased to about 200,000 acres, and in spite of the abundance of fresh water, it was thought advisable to push the work rapidly to avoid any possible trouble with salt water. Samples of water were systematically taken and analyzed during the early days of summer to determine the amount of salt present.

After the pumping season was well begun it was found that in spite of the abundant rainfall and consequent large surface drainage, tending to augment the supply of fresh water in the river, the salt water had worked its way up the river 63 miles from its mouth to a point very near Lake Arthur before it was finally cut off by means of the temporary dam. The mixing of the fresh and salt waters was largely due to the action of the tides, as well as to the fact that pumps along the Mermentau and its tributaries appropriate large quantities of the normal flow. The appearance of the salt water was so sudden and its increase so rapid that it became evident early in June that it must be shut out if the crop of 1903 was to be saved. Accordingly, the work was carried on day and night, and on June 19 the temporary dam was completed. It is believed that this prompt action

saved the crop of 1903. From this date until August 2, when the channel was again opened by removing the sheet piling forming the dam, there was an average head of 3 feet of fresh water above low tide held by the dam.

The drought which set in about the time harvesting was begun in 1903 and continued through the winter reduced the flow of water in the river and allowed the tides to mix the salt water far above the dam before the permanent structure was in place to keep it out. As the lock was incomplete, the opening had to be left in the dam, as the river could not be closed to navigation.

The dam is located  $1\frac{1}{2}$  miles below the village of Grand Chenier and below every bayou or other intake for salt water. It is 8 miles from the Gulf by river and 3 miles by land. This site was selected because the Mermentau is here only 422 feet wide and the banks are higher than at any other point below Grand Lake, the east bank being 8 feet above high tides, and the west bank, separated from the channel by 400 feet of marsh, is about 3 feet above high tide. From the west end of the dam, which is 422 feet in length, is a levee extending across the marsh to the west bank. Across the channel of the river were driven 108 piles in two parallel lines, the lines being 18 feet apart and the piles 8 feet from center to center. (Pl. VIII.) Piles 46 feet in length, 14 inches in diameter at the large end, and not less than 8 inches in diameter at the small end were used. The channel is 13 feet deep. The bed is composed of silt to a depth of 8 feet. Below the silt is hard blue clay; still lower is a layer of shells and quicksand, below which is red clay.

Between the two lines of piles was constructed a cofferdam, wherein was built the permanent structure, the inner rows of piles being 10 feet 10 inches from center to center. Against the upper line of outside piles was built the temporary dam of Wakefield piling 9 inches thick. Each Wakefield pile consists of three planks bolted together to form tongue and groove, which serve the double purpose of guiding the successive piles as they are driven and of making good joints between them. This temporary dam formed one of the walls of the cofferdam within which the permanent structure was built.

Still another row of Wakefield piling was used temporarily 2 feet outside of that, placed along the two outer rows of round piles for a large portion of the length of the dam. This was necessary because the action of the tides had caused the temporary dam to sway back and forth, and thus had helped to render it unfit to withstand, without great leakage, the pressure due to a considerable difference of head of water when the cofferdam was pumped out. These leaks had to be stopped by means of a "puddle chamber," filled with earth between the two rows of Wakefield piling just referred to.

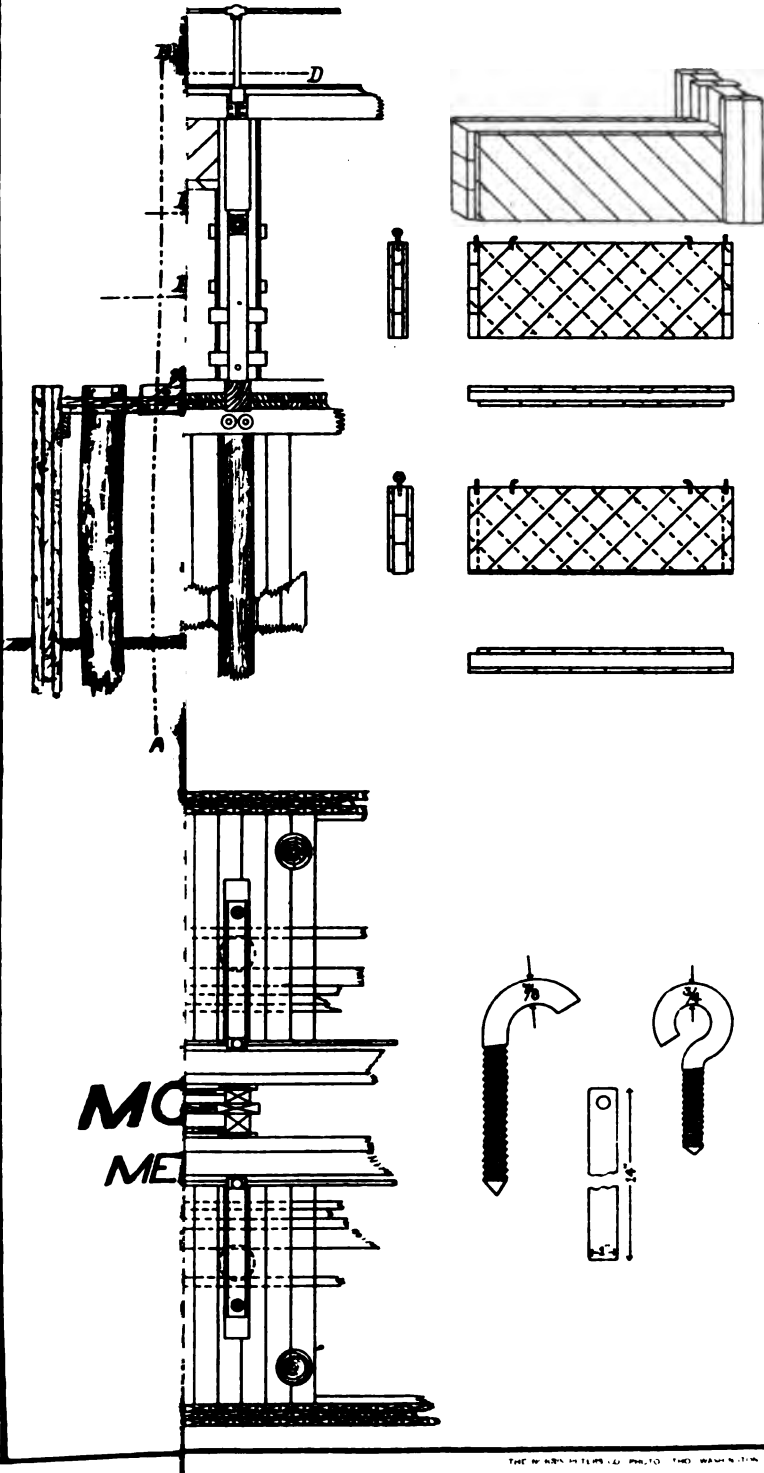



In the finished dam the outside rows of sheet piling have been removed, and the inner rows in the same have been cut off even with the top of the crosspieces, on which the superstructure is built. These piles were cut off after being firmly fastened to the dam proper by cutting first the round piles and then the sheet piling as far as possible from the inside and then breaking off the outside planks. The entire space between the two outer rows of Wakefield piling and the double floor shown in the cross section was "water filled" with earth, which contributes to the solidity and stability of the structure.

At the north end of the dam is a lock for the passage of vessels, with double gates both upstream and downstream. The lock is 150 feet long between the centers of its gates, is nearly 40 feet wide in the clear, and carries 8 feet of water below mean low water. Pipes 36 inches in diameter, both above and below the dam, provided with valves, are used to level up the water in this lock when desired. In the superstructure of the dam there are forty 10-foot shutters, which may be lifted in times of high water, leaving only the frame work to resist the passage of the water. This structure has been so designed that the openings are ample to accommodate any flood that is likely to occur.

All the timber used in the construction of the dam was treated with creosote, with the exception of the inside planks of the two inside rows of sheet piling, which are out of reach of the teredo, and the outer rows of sheet piling on either side, which were considered as temporary and were utilized merely to strengthen the structure. The creosote not only prevents the decay of the timber, but also protects it from the teredo, or shipworm, which eagerly attacks ordinary wood submerged in salt water and eventually destroys it. One and one-half millions of feet of lumber were required. The cost of the dam was approximately \$130,000.

It is believed that the dam will not only shut out salt water, but will also be the means of storing fresh water of the great natural reservoirs—Grand Lake, Lake Arthur, and Lake Miserie—besides a number of small lakes and thousands of acres of marsh land. The permanent structure of the dam was completed July 21, 1904, while sufficient progress had been made to shut out the water about March 1.

The estimated cost of the dam was greatly exceeded, as the magnitude of the undertaking was not realized until the work was well under way. It soon became evident that it would be impossible to pay for the dam by means of voluntary contributions, for, as already noted, many refused to contribute; accordingly an appeal was made to the United States Government. A committee was sent to Washington to ask Congress to contribute to the project, but without success. State aid was next sought and a bill introduced in the



Louisiana legislature providing for an appropriation of \$60,000 to complete the work. The bill was opposed on the ground that it was unconstitutional, and was abandoned.

Near the end of the session of the generally assembly, about July, 1904, a bill was introduced creating the board of commissioners for the Mermentau levee district, with authority to levy taxes on crops produced, property, and land in the territory specified in the act, which was practically the whole of the Mermentau watershed. Some of the provisions of the act are briefly as follows:

(1) To provide a tax on products raised in the levee district. This tax was not to exceed  $2\frac{1}{2}$  cents per sack of rice raised by means of water obtained from the Mermentau or its tributaries, and a similar tax on cotton, sugar, fruit, etc.

(2) To provide a levee tax of 10 mills on all property subject to taxation for levee purposes.

(3) To provide a tax not exceeding  $2\frac{1}{2}$  cents per acre on all land subject to irrigation within the levee district and \$50 per mile for all standard-gauge railroads within the district.

(4) Provision prohibiting all common carriers from receiving or removing produce on which the tax has not been paid and fixing a penalty for the violation of this provision.

(5) Provision authorizing and empowering the board of commissioners to issue bonds to the amount of \$200,000, the proceeds of which are to be used to pay for work done or in the purchase of levees, locks, and dams, and other works erected and purchased for the protection of the levee district.

The board of commissioners of the Mermentau levee district was appointed by the governor about the middle of September, 1904. In an address to the people of the district, published by the press of that section, they declared:

The purpose and intent of the proposed law was no more and no less than this: That the proposed levee district should be maintained by its pro rata of the State's engineer fund, and by a tax not to exceed  $2\frac{1}{2}$  cents per bag on rice raised on lands irrigated by water drawn from the Mermentau or its tributaries. It was contemplated that this tax should be paid by persons or corporations actually pumping water from the Mermentau and its tributaries—not by the users of such water, but by the pumpers of the water; that is, by the canal companies and persons maintaining private plants.

They further declared:

This pledge and public declaration means no more and it means no less than this: That if the law stands on the statute books and we are permitted to execute it, we shall levy no tax except the tax of not to exceed  $2\frac{1}{2}$  cents a bag on rice raised on lands watered from the Mermentau and its tributaries and contiguous lakes, which tax shall be paid by corporations or individuals actually pumping the water, irrespective of who uses the water.

It was claimed that the tax of 2½ cents per acre on land and the 10-mill levee tax would never be levied; that they were inserted to facilitate the issuing of bonds, and without these provisions it would be impossible to dispose of the bonds.

The opposition says that there is no guaranty that the board of commissioners will always be of this mind, and while the board first appointed may endeavor to carry out this plan, there is no guaranty that this will be the policy in the future with the possibility of a different personnel on the board. Meetings were held by men opposed to the act in various parts of the district, and it was decided to fight the law in the courts. Meanwhile, the board of commissioners had not organized and had never held a meeting.

An injunction was granted against the board on October 8, "enjoining, restricting, and prohibiting them, individually and collectively, from performing any of the functions or exercising any of the powers conferred on them by the law creating the Mermentau levee district, or in any way attempting to organize or carry into effect the provisions of said act."

Such is the present status of the case, which it is expected will be taken up during the present term of the district court.

Mention has previously been made of the lowering of the water behind the dam during the season of 1904 to a depth of 4 feet below mean tide level. The lowering of the water level caused some difficulty to navigation in the lower lakes. The United States engineer in charge of the territory in which the dam was built called upon the Rice Irrigation and Improvement Association to answer some questions regarding the dam and its effect on navigation. The answers to the questions were in substance as follows:

The Mermentau dam has saved the crop of 1904.

There is practically no freight traffic on the Mermentau during the summer season; the traffic on the river is practically all dependent on the rice crop. It is not considered that any damage has resulted; on the contrary, navigation would be ruined through the failure of the rice crop.

Dredging has been contemplated for bars which exist at the lower end of Grand Lake and at the mouth of the Laccasine in order to restore normal depth.

If the season could be begun with 2 feet of water impounded and the level reduced 4 feet it is possible that the present acreage of rice could be irrigated, for it is claimed that 2 feet above mean tide level means considerable more than 2 feet below on account of the spreading of the water over a large area of marsh land and swamp. Farming in the Mermentau country is becoming more and more diversified, causing a decrease in the acreage of rice to be irrigated.

The problem of keeping out the salt water is important not only to the rice growers along the Mermentau and its tributaries, but also to those having interests along Bayou Vermilion and Calcasieu River

in Louisiana and Taylors and Hildebrants bayous in Texas. In some of these cases there is a difference in the problem due to the lack of storage capacity. Along streams with a very limited supply of water it would be disastrous to increase the acreage of rice indefinitely, as that would mean ruin to all concerned.

#### USE OF WATER.

In many cases much more water was used during the season of 1903 than was absolutely needed by the crop. Two farmers along the canals, having the right to demand water as needed, often had their fields flooded to the full capacity of their levees to hold the water, just before a liberal rainfall occurred. This surplus water could not be held by the levees and would have given an undesirable depth of water over the fields if it could have been held, and so had to be wasted. The canal owners could but regret this waste, while the farmer, who was paying for the irrigation by means of a portion of his crop, regardless of the amount of water used, probably did not feel the same interest in the problem. It seems likely that some method of cooperation between the company furnishing the water and the men using it might result in its more economical use. If all water could be sold by measurement there would be a common interest which would of necessity develop a spirit of cooperation.

The owners of small farms, with their own wells and pumping outfits, are the masters of their own water supplies; they have the disadvantage due to small plants that are comparatively wasteful of fuel and must lose the benefits to be derived from doing things on a large scale, which the canal companies, with their larger and more economical plants, enjoy.

In some localities the small plants and wells are alone possible; in others, the planter may choose between the two methods. The experience of the first year in operating a large canal system has often been unsatisfactory because of unforeseen difficulties, such as breaking down of machinery or levees, or trouble due to inexperience. These troubles seldom appear after the first year; yet a failure to make a crop often leads to a desire on the part of the farmer to be able to regulate his own supply by having an independent plant. On the other hand, the small plants have been known to develop defects and to cause disappointments in various ways. Among the men who have tried both ways there are to be found advocates of each method. The conclusion arrived at is always governed by individual experience and must be settled according to local conditions.

Conditions during the season of 1904 were quite abnormal as regards the use of water. The field experimented with in Texas was late rice, and the two in Louisiana were even later. In every case the

irrigating was commenced in June. The abundant rains, which started during the latter part of June and continued throughout the remainder of the season, had the effect of reducing the amount of flood water to an unusually low amount in both cases in Louisiana, and to some extent in Texas. The conditions were different at the Texas station, as the field was watered from a well and there was no rainfall during the first three weeks of June and comparatively little for nearly a month following August 15. In one case in Louisiana the flood water was 5.01 inches of depth over the field and in the other 5.44 inches of depth. The former one was on a field near Estherwood, La., the same one experimented with last year, when 12.67 inches depth of flood water was required. These figures show the peculiarities of the season in a striking manner.

It is interesting to note that about four-fifths of the water used in 1904 was applied during the first three weeks after irrigation started, and that the rate at which it was applied was about the same as the rate in 1903, but the flooding season was shorter.

The early rice received a much larger quantity than the late rice in 1904, for the total water pumped into the Miller-Morris canal, from which the field was supplied, was sufficient to cover the entire area irrigated to a depth of 19.77 inches, the larger part of which was used on the early rice.

Individual farmers differ in their methods of flooding rice and in the amount of water which they consider will produce the best results. It is probable that other fields in this section, which were planted at the same time as those experimented with, received more water for this reason. While the peculiarities of the season of 1904 resulted in a large amount of flood waters for early and a small amount for late rice, another season with different meteorological conditions might reverse the order. Continued, well-distributed rains are accompanied by a humid atmosphere favorable to the growth of rice. The climatic conditions may render rainwater more efficient than the corresponding amount of flood water. Many consider rain as necessary for the successful raising of a rice crop, at least for the best results.

While some successful planters contend that it is only necessary to have the soil saturated with moisture, others claim that best results are obtained from a considerable depth of water up to the time of harvest. Apparently farmers are learning to use water more economically, realizing that it is possible to have too much as well as too little. As previously stated, water as commonly used in rice irrigation on the Gulf coast kills grass and weeds as well as supplying an essential to the growth of rice, and as the rice is not cultivated and weeds are rarely pulled, this function of water is important. In the following pages yields are stated in sacks per acre.

The results were obtained at the thrasher in the field. Rough rice as it comes from the thrasher is usually placed in sacks; the weight of the sack varies from 160 to 200 pounds, with an average value of about 180 pounds. Rice is sold in the rough by the barrel, which represents a weight of 162 pounds.

The unit of clean rice is the pocket which weighs 100 pounds. In general a barrel, or 162 pounds, of rough rice will produce 100 pounds, or 1 pocket of merchantable clean rice. The barrel, or 44 pounds, is not used as a unit in the measurement of rice in the Gulf coast country.

The price per sack for the crop of 1904 has varied from \$1.25 to \$2.30 per sack for Japan rice and from \$1.25 to \$3.30 per sack for Honduras.

#### DUTY OF WATER AT ESTHERWOOD, LA., IN 1903.

Two stations for the measurement of water used, of rainfall, and of evaporation were maintained in the rice country of Louisiana

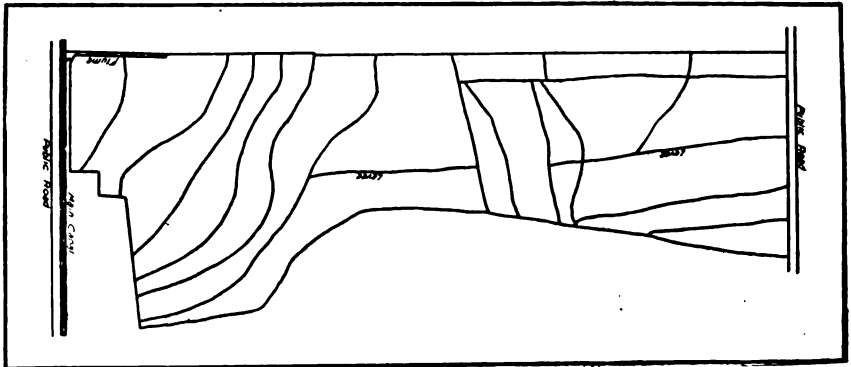

FIG. 68.—Plan of rice field at Estherwood, La.

and Texas during the irrigation season of 1903. One of these stations was located on the main canal of the Miller-Morris Canal, Irrigation and Land Company, about 3.5 miles south of Estherwood, La., while the other was located on a lateral on the main canal of the San Bernardo Rice Canal Company, of Austin County, Tex., about 10 miles northeast of Eagle Lake.

The soil about Estherwood is quite similar to that at Crowley and is characteristic of Acadia Parish. It may be designated as a loam clay. The subsoil is a heavy clay, in some places considerably stratified. The tract of land selected was located on the farm of S. A. Robbins and contained 170.68 acres, by accurate survey.

On this area water was used. However, the rice was not harvested on an area of 4.35 acres, on a portion of which the crop was so poor

that it was not considered worth while to harvest, and on another portion of which it was a total failure. About 1 acre of this latter was covered with the waterweed (*Pongatium zeylanicum*), which had attained a height of about 4 feet, no rice growing with it. The net area from which rice was harvested was 166.33 acres. Japan rice was raised, the total yield being 1,860 sacks, or 10.89 sacks per acre irrigated.

The measuring flume was located on the main canal. Figure 68 shows the plan of the field and the location of the levees. The rain gauge and evaporation tank were located in the field near by. The crop was planted about April 25. Irrigation was begun on May 29 and concluded on August 22, although water was not turned off until the following week. During this period the field received through the flume enough water to cover it to a depth of 12.67 inches. The rainfall during the irrigation season amounted to 19 inches, while the evaporation was 15.69 inches. This left 15.98 inches of water to supply that absorbed by the soil and taken up by the rice plants during the period of growth. The rainfall was over 20 per cent in excess of the flood water.

The following table shows the depth of water received by the Estherwood rice field during the thirteen weeks of the irrigation season, and also the weekly rainfall and evaporation at the station:

*Depth of water used on Estherwood rice field and rainfall and evaporation each week of the irrigation season of 1903.*

Week ending—	Flood water.	Rainfall.	Evapo-ration.
	<i>Inches.</i>	<i>Inches.</i>	<i>Inches.</i>
May 31 .....	1.90	1.20	0.68
June 6 .....	.40	.00	1.00
June 13 .....	2.01	1.00	.25
June 20 .....	2.11	2.58	.33
June 27 .....	1.15	3.31	1.81
July 4 .....	.05	2.00	1.25
July 11 .....	.01	1.92	1.42
July 18 .....	2.64	.79	1.91
July 25 .....	.05	.00	.94
August 1 .....	.19	3.00	1.44
August 8 .....	.00	1.00	1.37
August 15 .....	1.11	.54	1.42
August 22 .....	1.05	.70	.58
August 29 .....	.60	.96	1.44
Total .....	12.67	19.00	15.69

### DUTY OF WATER AT EAGLE LAKE, TEX., IN 1903.

The land of the San Bernardo Rice Canal Company is a red, sandy loam mixed with clay and has a heavy clay subsoil. The nature of the surface soil is quite variable, being in some places nearly a pure loam and in others composed almost entirely of clay; in general, however, it is a mixture of the two. The tract of land selected was surveyed and found to contain 71.18 acres; on a part of this field Hon-

durans rice was grown and on another part Japan rice. The total yield was 635 sacks, or 8.92 sacks per acre. The field was planted about May 10. The measuring flume was located on a lateral, as shown in the plat of the experimental field (fig. 69). The evaporation tank was placed near the flume, while for convenience of reading the rain gauge was located near the residence, a short distance from the field. Irrigation was begun June 30 and concluded September 2, while the water was turned off a week later. During this period the field received enough water through the flume to cover it to a depth

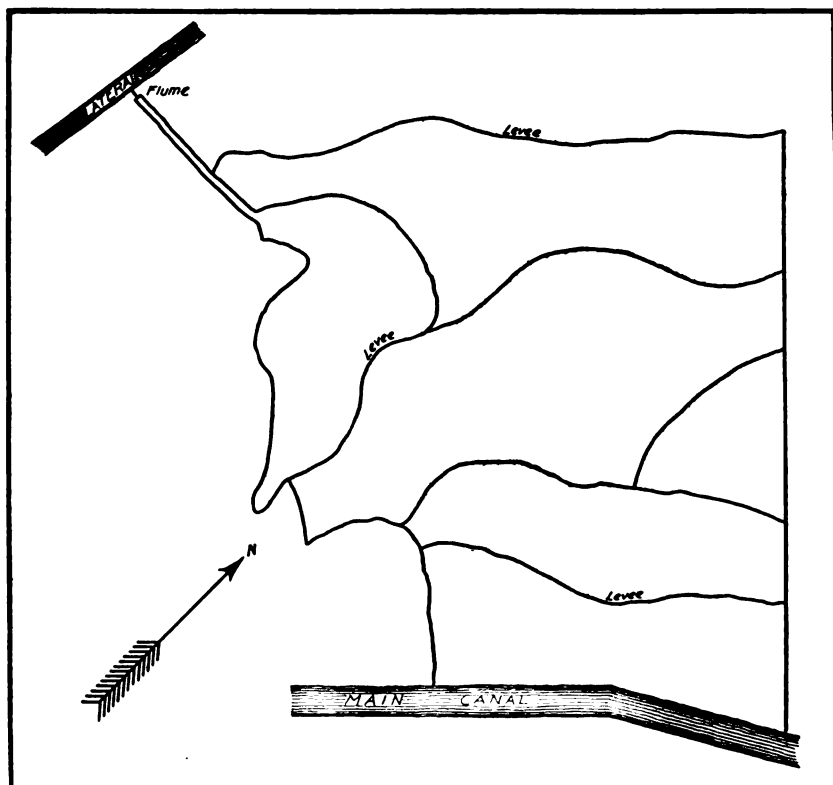

FIG. 69.—Plan of rice field at Eagle Lake, Tex.

of 7.37 inches. The rainfall during the irrigation season was 13.78 inches and the evaporation 9.83 inches. This left 11.32 inches net depth of water received by the land. During the week ending August 1 there was a very remarkable rainfall of 7.52 inches; the rice field had been liberally irrigated about two weeks previous and had received a small additional amount of water only a few days before this abnormal rainfall. The result was that there was an undesirable depth of water, even if the levees were capable of holding it, and so a portion of the water was wasted by cutting the levees.

There was no accurate way to measure the amount wasted, but it was estimated at one-half the total rainfall for that week, or 3.76 inches. Again, a break in an outside levee during the latter part of August caused a loss of water, which was replenished by the irrigation of August 31 and September 1 and 2. The amount of water used during these three days amounted to a depth of 0.77 inch. The amount of water on the field previous to this break was probably sufficient to mature the crop had no loss occurred at that time. All the measurements at this station were taken with the greatest care and are absolutely reliable; they are of great interest in spite of the fact that the net amount of water is not definitely known. If we disregard the two losses referred to above, the net depth of water absorbed by the soil and taken up by the rice plants during the irrigation season was 11.32 inches, while if we accept the estimate that one-half of the rainfall during the week ending August 1 was wasted, the net depth is reduced to 7.56 inches. Undoubtedly the true amount was somewhere between these two extremes, and therefore is of value, as it represents the minimum depth of water measured previous to 1904 in rice irrigation.

The following table shows the depth of water received by the Eagle Lake rice field during the ten weeks of the irrigation season, and also the weekly rainfall and evaporation at the station.

*Depth of water used on Eagle Lake rice field, and rainfall and evaporation each week of the irrigation season of 1903.*

Week ending—	Flood water.	Rainfall.	Evaporation.
	Inches.	Inches.	Inches.
July 4.....	2.44	2.77	0.85
July 11.....	.82	.00	.60
July 18.....	2.96	.00	1.20
July 25.....	.00	.00	1.20
August 1.....	.09	7.52	1.16
August 8.....	.00	.95	1.19
August 15.....	.00	.37	.49
August 22.....	.06	1.05	.82
August 29.....	.23	.73	.13
September 5.....	.77	.07	.67
September 12.....	.00	.16	.64
September 19.....	.00	.16	.88
Total.....	7.37	13.78	9.83

\* One-half wasted, making total rainfall retained on field 10.02 inches.

### DUTY OF WATER IN 1904.

During the irrigation season of 1904, three stations, for the measurement of water used, of rainfall, and of evaporation, were maintained in the rice country of the Gulf coast; two of these were in Louisiana and one in Texas.



Of the two stations in Louisiana, one was near Estherwood, on the farm of S. A. Robbins, the field experimented with being a part of that on which measurements had been made during the season of 1903. The other station was located near Crowley, on land owned by Abbott Brothers. Both of these experiment fields received water from large canal systems, the first from the Miller-Morris and the second from Abbott Brothers' canal.

The station in Texas was located on the farm of Mr. S. Phelps, in Wharton County near Nottawa, about 50 miles west of Houston. The water used was obtained from a shallow well and the records are the first obtained in well irrigation.

#### DUTY OF WATER AT ESTHERWOOD, LA., IN 1904.

Water measurements were made, as already stated, on a portion of the experiment field used last season, the area being 98.6 acres. Water was received through the same flume and all observations were taken by the same observer as during the season of 1903. The 1904 crop was later. The first flooding occurred between June 8 and June 20. Two other small floodings occurred later, but the quantity used in both cases was very small. The long period from June 30 to August 19 in which no flood water was applied to the field illustrated the peculiarity of the season of 1904 in this section, the rainfall being ample to offset evaporation and supply the needs of the rice for the greater part of July and a part of August.

Irrigation was begun June 9 and concluded August 27, and water was turned off about September 3. During this period the field received through the flume enough water to cover it to a depth of 5.01 inches. The rainfall during the irrigating season amounted to 18.52 inches, while the evaporation was 14.91 inches. This left 8.62 inches of water to supply that absorbed by the soil and taken up by the rice plants during the period of growth. The latter quantity is comparatively small. This field of rice, after receiving one flooding, experienced continued rain and the rains were accompanied by a humid atmosphere. No water was wasted on this field, and on the other hand, the rice did not suffer for water.

The yield, on the 98.6 acres planted, was 790 sacks, or almost exactly 8 sacks to the acre, nearly 3 sacks less than the previous year. Japan rice was raised.

The following table shows the depth of water received by the Estherwood rice field during the thirteen weeks of the irrigation season, and also the weekly rainfall and evaporation at the station.

*Depth of water used on Estherwood rice field, and rainfall and evaporation each week of the irrigation season of 1904.*

Week ending—	Flood water.	Rainfall.	Evaporation.
	<i>Inches.</i>	<i>Inches.</i>	<i>Inches.</i>
June 11.....	0.12	0.52	0.58
June 18.....	2.96	.21	1.68
June 25.....	.43	.00	.56
July 2.....	.61	2.05	1.93
July 9.....	.00	2.82	1.07
July 16.....	.00	3.26	1.51
July 23.....	.00	1.40	1.33
July 30.....	.00	3.96	.62
August 6.....	.00	.53	.84
August 13.....	.00	1.73	.67
August 20.....	.00	.44	1.75
August 27.....	.89	1.40	1.34
September 3.....	.00	.80	1.05
<b>Total.....</b>	<b>5.01</b>	<b>18.52</b>	<b>14.91</b>

#### DUTY OF WATER AT CROWLEY, LA., IN 1904.

The station near Crowley was located on land owned by Abbott Brothers, a short distance from the field on which water measurements were made in 1901. The rice was sown late and was first irrigated June 15, and continued to receive some water each day up to and including July 11. After this date there was a period of forty-three days in which no flood water was used. During the last days of August a small amount of flood water was again used. Water was turned off the field about September 17. During this period the field received through the flume enough water to cover it to a depth of 5.44 inches. The rainfall during the irrigation season amounted to 20.54 inches, while the evaporation was 13.30 inches. This left 12.68 inches of water to supply that absorbed by the soil and taken up by the rice plants during the period of growth.

The rainfall is seen to be nearly four times the depth of the flood water, the ratio being nearly the same as that at Estherwood during the season of 1904.

The area of the experimental field was 62 acres. From this area 334 sacks of rice were harvested, or an average of 5.38 sacks per acre, which is below the average yield for the Crowley district. The field was rather grassy.

*Depth of water used on Crowley rice field, and rainfall and evaporation each week of the irrigation season of 1904.*

Week ending—	Flood water.	Rainfall.	Evaporation.
	<i>Inches.</i>	<i>Inches.</i>	<i>Inches.</i>
June 18.....	0.93	3.60	1.96
June 25.....	.55	.00	1.44
July 2.....	1.62	1.95	1.70
July 9.....	1.51	.66	.90
July 16.....	.47	2.95	.91
July 23.....	.00	1.92	1.32
July 30.....	.00	.58	.70
August 6.....	.00	.58	.82
August 13.....	.00	4.98	.44
August 20.....	.00	.17	.88
August 27.....	.01	1.14	.46
September 3.....	.35	1.28	.68
September 10.....	.00	1.83	.73
September 17.....	.00	.00	.36
Total.....	5.44	20.54	13.30

#### DUTY OF WATER AT NOTTOWA, TEX., IN 1904.

The soil about Nottowa is a sandy loam with clay subsoil, the clay being 6 inches to 18 inches below the surface. There is a stratum of water-bearing sand and gravel underlying the clay, the thickness of the stratum varying from 12 to 20 feet, and its top being about the same distance below the surface of the soil. The field experimented with was supplied with water by means of a 5-inch horizontal-shaft centrifugal pump, rope driven from a countershaft, which in turn was driven by means of a belt from a 20-horsepower gasoline engine. The entire amount of water pumped by this plant was used on a 60-acre field, on which a crop was grown consisting in part of Japan and in part of Honduras rice. The yield was about 600 sacks, or 10 sacks per acre. The crop was sown the last week of May. Pumping was begun on June 3, and was continued daily up to and including August 3. By this time the rains in that section of Texas had become frequent and sufficiently abundant to make it possible that further pumping would be unnecessary. However, it was decided to resume pumping on August 22, and for over two weeks following that date water was again obtained from the well to flood the rice. All the water pumped was measured by means of a weir, as there was sufficient fall to allow its installation.

From June 19 to July 17 there was more or less trouble with the pump and rope drive, causing some delay, while both before and after this period the amount of water furnished was fairly uniform.

*Duty of water used on Nottawa rice field, irrigated by means of a well; also rainfall and evaporation each week of the season of 1904.*

Week ending—	Flood water.	Rainfall.	Evaporation.
	Inches.	Inches.	Inches.
June 4.....	0.25	0.00	1.50
June 11.....	1.60	.00	1.55
June 18.....	1.76	.00	1.60
June 25.....	.82	2.87	1.38
July 2.....	1.01	.50	1.37
July 9.....	1.34	1.30	1.05
July 16.....	2.02	.00	1.25
July 23.....	1.34	1.85	1.10
July 30.....	1.26	1.35	1.10
August 6.....	.60	1.65	1.03
August 13.....	.00	2.35	.82
August 20.....	.00	.45	.83
August 27.....	.28	.00	.81
September 3.....	.37	.45	1.01
September 10.....	.27	.40	.40
September 17.....	.00	4.50	.50
September 24.....	.00	.40	.65
October 1.....	.00	1.30	.30
<b>Total.....</b>	<b>14.12</b>	<b>19.97</b>	<b>18.25</b>

#### COMPARISON OF RESULTS OF WATER MEASUREMENTS IN RICE IRRIGATION FOR FOUR YEARS.

A comparison of the results of the measurements of the water required in rice irrigation during the last four years is of interest, as the dry seasons of 1901 and 1902 differed from those of 1903 and 1904 to a marked degree. The season of 1903 had a backward spring, following a winter of plentiful rain. The soil contained much moisture at the beginning of the season, and the continued and well-distributed rainfalls furnished water not only directly to the fields, but also gave a bountiful supply to the pumping plants.

The season of 1904 opened very early, with the soil in good condition to receive the crop, while for later planting it was too dry. The drought of the winter preceding the irrigating season of 1904 had been the cause of a shortage in the supply of irrigating water in streams and in wells. The rains of the latter part of June and on through the remainder of the season were timely, but nevertheless accompanied by peculiar climatic conditions, different from any previously experienced. The crop of 1904 was light in yield and poor in quality.

The table following gives a summary of results obtained in the water measurements of the last four years:

*Summary of results of measurements of the amount of water used in rice irrigation for the years 1901, 1902, 1903, and 1904.*

Year.	Location of station.	Depth from canal.	Rain-fall.	Total depth.	Evapo-ration.	Net depth. <sup>a</sup>	Season. <sup>b</sup>	Average evapo-ration per day.
		<i>Inches.</i>	<i>Inches.</i>	<i>Inches.</i>	<i>Inches.</i>	<i>Inches.</i>	<i>Days.</i>	<i>Inches.</i>
c 1901	Crowley, La. ....	16.47	10.04	26.51	14.47	12.04	63	0.230
c 1901	Raywood, Tex. ....	19.66	9.15	28.81	16.06	12.78	71	.226
d 1902	do. ....	19.71	11.08	30.79	11.08	13.34	91	.122
d 1902	Lake Charles, La. ....	23.64	7.10	30.74	11.53	19.21	77	.150
1903	Estherwood, La. ....	12.67	19.00	31.67	15.69	15.96	96	.100
1903	Eagle Lake, Tex. ....	7.37	13.46	20.83	9.83	7.56 to 11.32	84	.117
1904	Estherwood, La. ....	5.01	18.52	23.53	14.91	8.62	91	.164
1904	Crowley, La. ....	5.44	20.54	25.97	13.30	12.68	96	.136
1904	Nottawa, Tex. ....	14.12	19.97	34.09	18.25	15.84	119	.153
	Average .....	13.79	14.32	28.10	.....	c 13.52	.....	.162

<sup>a</sup> Water absorbed by soil and taken up by rice plants.

<sup>b</sup> Number of days in which rainfall and evaporation were measured.

<sup>c</sup> U. S. Dept. Agr., Office of Experiment Stations Bul. 113.

<sup>d</sup> U. S. Dept. Agr., Office of Experiment Stations Bul. 133.

\* Using the mean of No. 6.

### EVAPORATION.

The evaporation per day during the irrigation period as shown in the last column is interesting. It will be seen that the average result is 0.162 inch per day loss in depth, although the results show in one week an average of 0.226 inch per day, while in another week the amount is only 0.117 inch per day. These results were obtained for conditions approximating those in the rice fields and not for open reservoirs or canals. The methods of measuring evaporation were the same in all these years. In each case the evaporation tank was shaded to approximate conditions in the rice fields.

### PUMPING PLANTS.

The first pumping plant of any size used in rice irrigation in Louisiana and Texas employed a form of pump which had been used previous to the invention of the reciprocating steam engine. This pump consisted of vessels of cast iron, into which steam at a moderate pressure was introduced. On condensing the steam by means of a spray of water a vacuum was formed and water entered through suction pipes, partially filling the vacuum. The vessels were placed sufficiently high to allow the water to flow from them to the land to be irrigated. Of course valves were opened automatically to accomplish the various steps referred to above.

The process of pumping was necessarily slow, and consequently the capacity of a plant of moderate size was small when compared to plants of similar size but operating on more modern systems.

Worse than this, the pumps failed to act at a time when water was most needed, because the water used for condensing had become too warm, and consequently the vacuum formed was not sufficient to raise the water to the height of the vessels.

The prototype of this pumping engine was described in 1663 by an English nobleman, Edward Somerset, second Marquis of Worcester, who had used it to elevate water at his home, Raglan Castle. In all essentials the engine installed in 1894 on Bayou Plaquemine, near Crowley, La., agreed with the ancient model. However, in the older pump the water was forced from the vessels to a higher level by the direct action of steam on its upper surface. The engine above referred to was more of a scientific toy than a practical pumping engine. Savery obtained a patent in 1698 on an improved design of a "fire" engine of this type. His engine was the first to employ steam in removing water from the deep mines of Cornwall, England. It was used for many years for this purpose, and, in spite of great defects, was a pronounced success for that time. The results of a test of one of these engines made in 1774 show that about one-half of 1 per cent of the energy present in the fuel was utilized as useful work, a result which is comparable with that of many of the simple noncondensing pumps of today, in which steam at a little less than boiler pressure is carried for full length of stroke—such pumps as are used for boiler feeders.

In marked contrast to this crude beginning are the large pumping plants now used in the rice belt, many of them employing the most approved modern machinery—the boilers, engines, and pumps often of the latest design, furnishing water economically and in immense quantities.

#### **PUMPING PLANTS OF THE LARGE CANALS.**

The equipment of the pumping plants of the rice irrigation canals is, in general, good. Already the working of the law of the survival of the fittest is weeding out the poorly designed plants and resulting in good examples of engineering where changes have been made and in the newer plants. Occasionally, however, examples are to be found in which crude, wasteful machinery is used, operated by unskilled labor, at great expense for fuel and repairs.

There are also many plants in which all the machinery is mechanically good, but the requirements for economy are entirely lacking. The fault is usually with the engines.

Boilers of various designs are used to furnish steam to the engines. Either the fire-tube or the water-tube type will give results that are similar as to economy, provided they are properly designed and the boiler capacity is sufficient to furnish steam to the engines without forcing. Often the deciding factor in the selecting of a steam boiler

for a particular locality and use is the ease with which it can be cleaned and repaired, if the water used is such that scale or sediment is deposited.

While there is much to be learned in regard to the different types of pumps used in the large irrigation plants, enough is already known to enable the designer of a new plant to avoid serious errors as to capacity or efficiency.

The selection of a proper engine is one of the most important considerations in the design of a pumping plant, for, as has already been stated, the engine is a large factor in determining whether a plant shall be economical or wasteful. The engines used vary from the compound-condensing Corliss down to the ordinary noncondensing slide-valve engine. In any case, the problem is one of adjusting and equalizing the annual interest and depreciation on the increased cost of the more expensive plant, with the amount it would save in fuel over the uneconomical plant.

While individual cases will vary within wide limits, depending on particular conditions, such as economic loading and the size of the units employed, yet in general it may be said for the engines commonly used in the larger pumping plants of the rice country that the consumption of steam per indicated horsepower hour is about as follows:

	Pounds.
Compound condensing Corliss.....	15-20
One-cylinder Corliss .....	25-30
Plain slide valve.....	30-40

If the mean values, as given above, be taken as a means of comparison the following results are obtained:

	Pounds.
Compound condensing Corliss.....	17½
One-cylinder Corliss .....	27½
Plain slide valve.....	35

When it is remembered that the plain slide-valve engine to produce a certain horsepower requires two times as much steam and that the one-cylinder Corliss requires 1.57 times as much as the compound condensing Corliss requires for the same work in the average case, it will be seen that not only a great economy of fuel can be effected, but that the boiler equipment for a given output may be materially reduced by using the economical engine. The use of feed-water heaters to utilize a part of the heat of the exhaust steam will produce an economy of as much as 10 per cent in some instances, making the comparison a little less striking than that given above. However, the amount saved on the boiler equipment in an economical plant over the cost of boilers to supply steam to wasteful engines for an uneconomical plant is often nearly sufficient to offset the higher cost of the better engine, making the first cost practically the same in the

two cases. Even if the first cost of the economical plant is slightly more, the operating expenses will be reduced sufficiently to more than compensate for the increased cost. Two plants of equal capacity, one economical and the other wasteful, may each be entirely satisfactory so far as smoothness of running and reliability are concerned, but the cost of fuel in the two cases will be very different. The better-designed plants furnished water at a cost for fuel, labor, maintenance, etc., of from \$2 to \$3 per acre irrigated during the seasons of 1903 and 1904, while with the more wasteful plants the cost was as much as \$4 per acre. The need of an economical plant is especially felt where the water has to be lifted to a considerable height. The cost of fuel depends on proximity to the oil fields when fuel is crude oil or to railroads where coal is used. Many of the large plants near the oil fields have pipe lines from the oil fields or storage tanks on lines of railroads.

Up to the past two years the planting of rice under favorable conditions has produced handsome profits and questions of economy have been too often overlooked. But as the margin of profit has become less the question of the economical operation of pumping plants has become of vital importance.

#### **RESULTS AT TWO LARGE PUMPING PLANTS.**

During the season of 1904 complete records were kept at two large pumping plants in Louisiana of all important facts in connection with the operation of the plants for the season. These records included the hours and minutes of each day's run, the boiler, engines, and pumps used, the level of the water supply, and the amount of fuel.

A comparison has been made from these daily records showing the relative cost of pumping water in the two cases. This comparison is interesting, as the plants are both large, the head pumped against, while not the same, is approximately so, and the difference in head has been considered in the comparison. The pumps were of different types in the two cases, but the approximate efficiency of each type is known.

The most striking difference in the two plants is to be found in their engine equipment, for in one case the most wasteful type is used, while in the other a very economical type is employed.

#### **THE MILLER-MORRIS PLANT.**

The plant of the Miller-Morris Canal Irrigation and Land Company is located near Estherwood, La., and takes its water from Bayou Plaquemine. Its equipment consists of two boilers, 72 inches in diameter and 16 feet in length, each containing one hundred and



twenty 3-inch tubes, and eight boilers 60 inches in diameter by 16 feet long, each containing forty-six  $3\frac{1}{2}$ -inch tubes. All the boilers are horizontal return tubular. There are five engines, four of which are 125 horsepower and one of 250 horsepower; all are of the simple, noncondensing, slide-valve type.

Centrifugal pumps are used; they are connected to the engines by means of rope drives. Four of these pumps have a nominal capacity of 16,000 gallons per minute, or 35.6 cubic feet per second each. Two have a nominal capacity of 8,000 gallons per minute, or 17.8 cubic feet per second.

The plant was visited early in May, 1904, and the flume rated with the various pumps in use, starting with one and adding pumps successively until the whole plant was in operation. At this time the plan was to use a water register on the flume, and so have a record of all water pumped into the main canal during the entire season. This plan had to be abandoned, as the water of the canal backed up into the flume, and as the level of the main canal fluctuated the records were worthless. However, in measuring the discharge from the pumps, the amount thrown by similar pumps in each case was approximately the same, and the result so consistent that it was found feasible to take the records of daily runs and, knowing the hours and minutes that pumps were operated, to compute the discharge on this basis. The level of the water in the bayou varied somewhat during the season, but it is believed that the quantity of water thrown in a given time by any of the pumps was practically constant, as the speed of the engines was increased as the level of the supply fell and the plant handled in an intelligent and satisfactory manner throughout. Of course, it is impossible to have absolutely accurate measurements under these circumstances, but the error is certainly not over 10 per cent, and probably is much less. The plant was put in order and the first pumping of the season occurred just after the middle of April; the greater part of the pumping occurred, however, between the dates of May 10 and July 1. Small amounts were pumped the third week of July and the latter part of August, and pumping was discontinued on August 31. During this time a volume of 541,577,400 cubic feet of water, or 12,432 acre-feet, was pumped. The area irrigated was 7,544 acres, the average yield from which was about 8.6 sacks per acre. The water pumped was sufficient to cover the area irrigated to a depth of 1.648 feet, or 19.77 inches.

The average head pumped against was 20.2 feet; it was computed by multiplying the amounts of water pumped in periods of time in which the head did not vary greatly, by the average head for each period, and dividing the sum of these products by the total amount of water pumped. The total amount of useful work done in pump-

ing the water against the average head was 341,870,233 foot-tons. The fuel used was crude oil and the amount used was 8,473 barrels of 42 gallons each. The cost per barrel was 70 cents delivered at the plant. The work done per barrel of oil was 40,348 foot-tons.

#### THE ABBEVILLE PLANT.

The pumping plant of the Abbeville Canal Company is located on Bayou Vermilion a short distance below Abbeville. Its equipment consists of two horizontal return tubular boilers 72 inches in diameter by 16 feet in length, each containing 70 tubes 4 inches in diameter. There are two tandem compound condensing Corliss engines, of about 250 horsepower each, direct connected to Connersville pumps, each having a capacity of 40,000 gallons, or 88.8 cubic feet per second. These pumps are of the rotary or chamber-wheel type, and, unlike the centrifugal pump, their action is positive. It has been claimed that these pumps are meters, and that they therefore deliver an amount of water at each revolution which is equal in volume to the displacement of the pump; but it is probable that the slip in every case is appreciable, inasmuch as it is impossible to make these pumps mechanically perfect. Experience shows that this slip will amount to 5 to 15 per cent, depending on circumstances—such as the age of the plant, care and adjustment of pumps, the head pumped against, etc. It is believed that the slip of the pumps at this plant during the season of 1904 was probably as low as 5 per cent. The discharge was computed on the basis of pump displacement, knowing the hours and minutes pumps were operated each day and the revolutions per minute. Pumping was begun on April 10 and ended on August 10. During this time a volume of 450,526,231 cubic feet, or 10,343 acre-feet, of water was pumped against an average head of 17.5 feet. Nearly 88 per cent of this water was pumped before June 20.

The area irrigated was 5,175 acres. The water was therefore sufficient to cover this area to a depth of almost exactly 2 feet. The total yield was 46,445 sacks of rice, or an average of nearly 9 sacks per acre. The total amount of useful work done in pumping the water against the average head was 246,381,532 foot-tons. The fuel used was crude oil, and 1,950 barrels were required. The cost was 81 cents per barrel, f. o. b. Abbeville.

The work done per barrel of oil was 126,350 foot-tons. A comparison of total cost of operating these two plants would be of interest, but of course local conditions affect the cost of operating each plant. The age of the plant will largely govern the amount of repairs required, while if the canal system be included the contour of the country and consequent number of wooden flumes or high embankments will be different in individual cases. Proximity to the oil fields or to main lines of railroad reduces the cost of fuel, as already noted.

The point to which attention is particularly called is the amount of work done per barrel of oil, which at the Miller-Morris was 40,348 foot-tons, and at the Abbeville plant 126,350. These amounts are in ratio of 1 to 3.13. This difference in the total efficiency is not to be entirely charged to the difference in the engines used, as the rotary pumps of the Abbeville plant are probably more efficient than the centrifugal pumps of the Miller-Morris plant. The truth of this statement does not follow because one type is necessarily more economical than the other, for both will show splendid efficiencies under proper conditions. The centrifugal pumps must be run at their economical speeds for best results, while the efficiency of the rotary pump is not so dependent on speed. The economical plant had the advantage of operating larger units, which are always slightly more efficient than small units. It had the further advantage of pumps direct connected to engines, while the wasteful plant was rope driven.

For a contemplated plant of approximately the size of the two mentioned above, to furnish a stated amount of water pumped against a required head, it has been found that the total cost erected complete, including building, foundations, boilers, engines, pumps, accessories, piping, etc., at the present prices will not be far from \$100 per water horsepower—that is, for every horsepower of useful work given out by the pumps, in case compound condensing Corliss engines are used, or engines in the same class as regards efficiency. The less economical plant with the cheapest form of slide-valve engines will cost about 10 per cent less.

A comparison to determine which of these two plants would be the better from a financial standpoint would include not only the cost of operating, but also the interest on the money at the current rate—say, 5 per cent—and the depreciation of each plant at about 10 per cent per annum. With fuel oil, the favorite fuel in this season, the cost for labor of operating would be practically the same in the two cases, while if coal is used the increased boiler capacity and fuel consumption would call for more firemen and more labor in handling coal in the wasteful plant.

When this comparison is made it will be found in the average case that the saving in fuel with the compound condensing engines will more than offset the difference in the interest on the investment and depreciation and that the more expensive plant is the best proposition.

#### SMALL PUMPING PLANTS.

On rice farms that are irrigated by means of wells, two general types of engines are used—the steam engine and gasoline or oil engine. The steam engines, being of comparatively small size, are usually simple, noncondensing; sometimes traction engines are used

and some of these are compound. As the pumping and thrashing seasons never conflict, the small farmer is enabled to use his traction engine for both purposes and thus effect an economy in equipment. Many of these small plants consist of a stationary boiler and a horizontal engine. Sometimes two pumps are run from a single engine, the wells being 50 to 75 feet apart. These small traction and noncondensing stationary engines are very wasteful of steam and consequently of fuel, but are reliable and require but little skill to operate.

Gasoline engines are extensively used in some localities. When properly installed and adjusted this type of engine is satisfactory, usually requiring less attention and skill than the steam engine and operating more economically. In at least one make of these engines a "generator" has been used whereby the more volatile portions of crude oil are distilled and used as fuel instead of gasoline. The heavy residue, containing asphaltum, tar, etc., must be removed from the generator at intervals of three or four days. This involves some labor and trouble at a time when the rice farmer is busy attending to field levees and the distribution of water. The experience of the men who have used this apparatus differed; some reported that their engines ran with crude oil quite as well as with gasoline, while others encountered difficulties. The cost of operating with crude oil is about one-half that of operating with gasoline. The heavy residue obtained in the process of distillation is quite as good for burning in a furnace to produce steam as is the crude oil. In some cases it has been exchanged barrel for barrel with a neighbor who used a steam plant.

Many of the men who operated engines by means of crude-oil distillate in 1903 preferred to employ gasoline in 1904, for although gasoline is more expensive this objection was offset by increased reliability.

A central plant in which an electric current is generated has been employed to furnish power to run several pumps scattered over a rice farm. A 6-inch pump will, in most localities, furnish sufficient water for 75 to 100 acres of rice. By suitably spacing the wells a large area may be watered economically in this way, as the canals and laterals required by this system are comparatively small, and the cost of wire and poles for the electrical transmission might for some conditions be less than the canals of the usual system would cost. In case the problem is to be worked out on a large scale the units at the central station would be sufficiently large to justify the use of very economical machinery.

### FUELS.

Crude oil continues to be used as a fuel in localities adjacent to the oil fields and quite generally throughout the rice country. The oil-producing area of Louisiana and Texas has been considerably increased during the last year. Many believe that a practically inexhaustible supply of oil will be found, and should this prove true, crude oil will continue to be the favorite fuel of this section. The discovery of oil in Texas preceded by a few years only the falling off in the production of fields of Indiana and Ohio. The demand for refined oil must be met first and the surplus crude oil used for fuel purposes. The problem of refining the crude oil from some sections of this territory is peculiar, but no doubt will eventually be successfully accomplished. Refineries are being established, and if the price of the crude oil to be refined does not become too great and therefore prohibit its use as a fuel, it will continue to be used to generate steam. At present there appears to be an assured supply for at least the next five years. Meanwhile, it is likely that new fields will be discovered.

Fuel oil is used not only in the pumping plants of the rice country, but in all kinds of service, from traction engines to locomotives, as well as in various commercial power plants.

Coal is used in some localities, but the comparatively long distance from the coal fields makes it expensive. It is less easily handled than oil and requires more labor in firing.

### TEXAS STORAGE DAMS.

The rivers of Texas are subject to floods, which are often sudden and disastrous. On account of the abnormal rainfall of the winter of 1902 and spring of 1903, the floods were unusually severe. The beds of the rivers, in which storage dams are placed, are in many places composed of sand and gravel to a depth of 20 or 30 feet before clay is reached. Water percolates through this bed, so that there is in reality more or less flow when the surface of the bed of the stream is dry and the sand drifting over it.

The problem of designing a dam that will be able to withstand the terrific floods which sometimes occur in these Texas streams and rivers is a different one when the nature of the soil is considered. Sand and gravel yield with the greatest ease to erosion, due to whirlpools or to rapid flow of water. For a permanent dam it is absolutely necessary to guard against erosion, for in this material, when once erosion is well started, it is almost impossible to check or stop its action. If the dam be of any but the most substantial material and design disaster is reasonably certain to follow a sudden downpour of

rain in the watershed of the stream whose waters it is desired to impound.

During the season of 1903 two dams in Texas were visited which are used exclusively for irrigation purposes. In both cases the dams had failed, and in one instance had failed more than once.

### **UNPOLISHED RICE.**

After the husk and cuticle of the rice grain are removed, the outer portion, which is of a dull white color, contains most of the fats and albuminoids. Custom demands that this outer portion be removed and a pearly luster be given to the grain, as it is sold entirely on its appearance. The process by which this is done is called "polishing." The "brush" and accessories used to polish rice sometimes require 30 to 40 per cent of the total power of the mill.

In oriental countries rice is never polished. The value of the cereal as a food is much greater when unpolished, as polished rice is nearly pure starch. The fats and gluten of the outer portion of the grain give it flavor and render it far more palatable than when polished.

The process of milling would be simplified and cheapened, as less power would be required if the rice were not polished; a saving would be effected, not only in the cost of milling, but also in the quantity of rice. The amount removed by the process of polishing amounts to 2 or 3 per cent, by weight. Unpolished rice is never offered for sale and is never used in this country outside of the rural districts where it is prepared by mortar and pestle in the most primitive fashion. Many persons have never seen the unpolished article and would not buy it if offered, as its appearance is unprepossessing. There are few who realize that by improving its appearance its value as a food has been greatly reduced. Under these circumstances the mill men are compelled to polish their rice in order to sell it.

### **OIL AND FEED FROM RICE.**

During the season of 1904 a mill has been erected at Crowley, La., for producing feed and corn products. Rice, rice bran, and corn are the principal constituents of the feed produced. Oil is obtained from the rice bran and is said to be similar to palm oil, of an excellent quality, suitable for the manufacture of toilet soap. When it becomes better known it may be found suitable for many other purposes.

The oil in rice bran causes it to become rancid and to heat in warm climates. In this condition it is distasteful and harmful to stock. The removal of the oil, therefore, not only gives a valuable by-product, but also improves the keeping qualities of the feed.

### RICE STRAW.

Some rice straw is now used as a forage for stock, and the straw is sometimes baled and placed on the market. But only a very small percentage of the total yield is used in this way. Thousands of tons are allowed to waste each year, as it is considered a rather undesirable by-product, of small value. From a single point of observation in the rice country it is not unusual to count as many as a dozen immense piles of straw which are not being utilized in any way.

The men who have so rapidly developed the rice industry in Louisiana and Texas have had so many new problems to solve along other lines that the rice straw has been almost neglected. The growing scarcity of paper material in the last few years, and especially of wood pulp, has caused a consideration of rice straw as a substitute in the manufacture of paper. In China and Japan an excellent grade of paper is made from this material, and it is believed that factories will eventually be established in this section for the manufacture of paper and strawboard.

# RICE IRRIGATION ON THE PRAIRIE LAND OF ARKANSAS.

By C. E. TAIT,

*Assistant in Irrigation and Drainage Investigations.*

Arkansas contains some distinctly prairie land situated in the central eastern portion of the State. This land is very flat and has an altitude of 216 feet. The soil is not rich and rarely exceeds 8 inches in depth. The prairies are very wet during the spring season, but during the late summer and fall become dry. Cotton and corn have not been successfully grown on the prairie land, and for years the problem has been to find out what crop would be profitable to the farmers.

Just after the close of the civil war the prairie land could be bought for 50 cents per acre. The value has steadily advanced since that time, and the prices asked at present vary from \$8 to \$25 per acre. It is probably safe to say that two-thirds of the land has never been cultivated. The native grass is allowed to grow, and in recent years a good part of this has been cut and marketed for hay, although the growth on many acres is burned off each fall.

## **EARLY EXPERIMENTS.**

Four or five years ago the attention of the public was called to the small pieces of rice which were being grown in the low swampy places along the bayou. Among the most successful in this kind of rice culture were certain negroes, who raised enough rice for their own table use. In 1899 Mr. W. H. Fuller, a farmer living on Prairie Longue, near Carlisle, Ark., who had come to the State from Ohio, commenced preparations for growing rice by irrigation, believing that rice could be grown on the prairie land as successfully as it was in southern Louisiana. He drilled a 4-inch well and provided a pump with such ample power that when the machinery was started the strainer on the well collapsed. The rice sown that year was a failure, but Mr. Fuller, being still determined to make it a success, rented his farm and went to Louisiana, where he remained four years in the rice district about Crowley and Jennings.

In 1902 arrangements were made for a rice experiment on the farm of John Morris, which was just across the road from Mr. Fuller's farm. A small stock company was organized in the town of Lonoke,



where a number of merchants and enterprising citizens each contributed \$25 to form a fund for making preparations for the irrigation of the rice. Judge George Sibley was president of the company and Mr. W. H. Vivion, a fruit grower near Lonoke, was secretary. They arranged with Mr. Morris to have the rice grown on his farm and under his management. The Arkansas Experiment Station was interested in the test to be made and furnished the seed, but having little funds for the purpose could not lend any more material assistance. While this attempt at growing rice was only partially successful, it has been the means of bringing about more attempts in the same direction.

A 10-inch well was drilled on Mr. Morris's farm. Water was struck at a depth of 70 feet. Twenty feet of Cook strainer was then placed in the water-bearing stratum, making the total depth of the well 90 feet. The well was drilled by local men who had had no previous experience, but when it was time to place the strainer the services of a well driller of Memphis, Tenn., were secured. When water was struck, it rose in the well to within 27 feet of the surface. The pump used was a 6-inch Morris centrifugal of the horizontal type, which was placed in a pit 25 feet deep, making it necessary for the water to be drawn 2 feet to the pump by suction. The pit was round, 10 feet in diameter, and was curbed with brick. The power was furnished by a 12-horsepower engine and stationary boiler. The engine was placed with the band wheel directly over the top of the pit, and the belt hung vertically to the 10-inch pulley on the horizontal shaft of the pump below. It was found that this was a very poor arrangement, for all the sag in the belt was at the lower pulley, and it was almost impossible to prevent slipping. Two heavy idlers were used before the belt would work at all. Many other difficulties were experienced in getting the machinery to operate. The first pump used could not be made to raise any water at all. After three days of hard labor the pump was run backward, which also failed to give any result, and it was then taken out and a new pump sent for. The second pump worked fairly well, but it was found that the power was barely sufficient. While the engine was rated at 12 horsepower, it was probably not capable of developing that much. The pump being above the water level, it was necessary to prime it in starting. It finally became necessary to haul water in a portable tank and turn it into the discharge pipe of the pump when the machinery was started.

About 30 acres of rice was planted. After it had been flooded, the levees, which had been carelessly made, broke and a great part of the water which was pumped was lost, the result being that only about 5 acres received as much water as was needed. The yield on this was very large and was enough to indicate that rice could be successfully

grown if the problem of a water supply could be solved. The experiment was continued in 1903 and was more successful. The levees had set, and while the well and pump did not furnish enough water for the entire acreage all the water raised was used. It is claimed that that part of the rice which received a sufficient quantity of water yielded 90 bushels to the acre.

### RICE EXPERIMENT STATION.

In 1904 arrangements were made for a cooperative experiment with the Arkansas Experiment Station. The fund set aside for this work by the irrigation and drainage investigations was \$1,500 and that set aside by the Arkansas Station was \$1,000, making a total of \$2,500 available for carrying on the work to July, 1905.

Several things were to be determined by the experiment. It would show whether the poor prairie soil was capable of growing rice or not. Lonoke is 300 miles north of the Louisiana-Texas belt, and the rice could not be planted as early as it is in the South, but the experiment would show whether or not the summer season was long enough to mature a crop. While the well at Lonoke does not extend to the bottom of the water-bearing stratum found and while the pump does not exhaust the well, a complete test of the amount of water that can be secured and pumped has not been made, but the experiment would prove whether or not water could be pumped from wells in quantities sufficient to make rice growing possible. In addition to testing the possibilities of rice culture the experiment was designed to determine by the most practical method the cost of sinking wells, of the installation of pumping machinery, and of the cost of pumping water, and this when compared with the results would determine the practicability of the entire work. The experiment also would show the amount of water required for the irrigation of rice.

The Arkansas Experiment Station arranged for the use of 160 acres belonging to Mr. W. P. Fletcher, located about 1.5 miles west of Lonoke, Lonoke County, Ark. The land is among the best to be found on the Arkansas prairies, but had never been under cultivation. It had formerly been used as a common pasture and was not fenced. Mr. Fletcher agreed to fence the land and to build a house on it to be occupied by the one having charge of the raising of the rice, if it was desired. Only about 10 acres were broken for experimental purposes, and after the 160-acre tract had been fenced and the house built about 40 acres were inclosed by a fence which surrounded the experimental tract, in order that the remainder might be used for pasture. It was arranged that the irrigation and drainage investigations should make preparations for the irrigation of the rice, which included the sinking of a well, the installation of pumping machinery, and the con-

struction of levees around the field to hold the water, after which the Arkansas Experiment Station was to take charge of the farm and operate the pumping plant.

The first step to be taken toward securing the water supply was to make arrangements for the sinking of the well. It was believed from the great number of small wells for domestic purposes and from the well at the Morris place that water would be found at a depth of 70 to 80 feet below the surface. It was not known how thick this water-bearing stratum was, because no wells had yet been drilled deep enough to go through it. It was decided that an 8-inch well having 30 feet of strainer placed entirely in the water-bearing stratum, if possible, should furnish plenty of water for the experimental work, and bids were accordingly received from all the well drillers in Little Rock and Memphis. The contract was let at \$4 per foot, the contractor furnishing pipe and strainer. It called for the completion of the well within twenty days of the date of the contract, or by March 24. It is believed that the price paid is reasonable and compared very favorably with the price paid in the rice districts of Louisiana and Texas, where there are many well drillers in competition.

The well was begun by boring with an earth auger to a depth of 27 feet, where quicksand was struck, which caved in, and other means had to be used. The pipe was then inserted and the well was finished by the use of the sand bucket.

The strainer agreed upon and the kind with which the well was supplied was made by drilling 1,100  $1\frac{1}{4}$ -inch holes in 30 feet of 6-inch well casing, the holes being arranged in 6 rows around the pipe. The pipe was then filed and tinned, after which irrigating gauze made of copper wire, having heavy wires running around the pipe with lighter wire running along the pipe, was wound about the casing and soldered in 6 rows between the rows of holes. Gauze of this kind is sometimes woven very closely, which keeps out very fine sand, but which, of course, does not admit much water to the well. The gauze which was used, being of heavy wire and woven openly, served to admit plenty of water, and as the sand encountered was rather coarse, the strainer was well adapted to the conditions. The crimped fashion in which the gauze is woven allows water to pass through the strainer at any point, whether it be directly over a hole in the well casing or not, after which it may flow along the pipe under the gauze until it reaches one of the holes. This gives the strainer almost the full advantage of the entire area of the perforations, while if the water could not enter at any point and follow along the pipe the actual opening would be greatly reduced by the space taken by the wires covering the holes. Several other strainers have been designed recently which accomplish this purpose.

One hundred feet of pipe was used in sinking the well. Water was struck at a depth of 80 feet, and in thirty minutes a measurement was made and the water level was found to be only 27 feet below the surface. This was in the evening. The next morning when work was begun it was found that the water had risen to within 26 feet 3 inches of the surface, which level was maintained.

The various strata encountered in sinking the well consisted of yellow and brown clays 5 to 14 feet thick, separated by 5-foot layers of white or red sand to a depth of about 70 feet, where fine sand, water bearing to a small degree, was found. A few inches of blue clay at 74 feet separated this fine sand from a coarse white sand below, which was also water bearing. Then 6 inches of hard clay was perforated at a depth of 80 feet, below which was found the excellent water-bearing sand and gravel to a depth of 114 feet, the total depth of the well. The latter is the stratum from which the well derives its water. The sand is rather coarse, containing gravel as large as 2 inches in diameter. When the 6 inches of blue clay was perforated by the sand bucket the force of the water, which seemed to be confined under pressure below this stratum, drove the sand bucket upward several feet.

The strainer was placed by lowering it in the 8-inch pipe and using a smaller sand bucket. It was the intention to sink the well only deep enough to allow the entire length of the strainer to be set in the water-bearing stratum, and had there been no obstacle in the way it would have been necessary to place the bottom of the strainer at a depth of only 110 feet and the 8-inch pipe could then have been withdrawn 20 feet, leaving the strainer all exposed; but since the water rose to a depth of 26 feet 3 inches from the surface, it was desired that a joint of the pipe be left at a depth of 30 feet, where the pump could be attached. The joints of 8-inch pipe were in 10 and 20 foot lengths, and it was found that the arrangement would not allow a joint to come at a depth of 30 feet, so it was necessary to sink the strainer 10 feet farther to bring about the proper condition. An attempt was made by the well drillers to do this, but after a depth of 114 feet was reached the strainer could not be lowered any farther. After working two days with the sand bucket without gaining anything, it was decided that the strainer could not be lowered any farther by this means, for the sand and gravel rose to the bottom of the strainer as fast as it was taken out by the sand bucket. The 8-inch pipe was then withdrawn 10 feet, leaving the upper 6 feet of the strainer inside of the pipe. The upper end of the strainer carried a lead packing, the upper edge of which was expanded until it was clamped to the inner side of the 8-inch pipe, thus making a rigid connection between the pipe and the strainer. (Fig. 70.) This was accomplished by means of a cone-shaped tool which was lowered in the well and allowed to fall on the lead packing. The lower end of the strainer was then

closed by means of two disks which were fastened together on an iron rod about 1 foot apart. This was forced to the bottom of the strainer and two buckets of gravel was poured in on top of it. (Fig. 71.)

The well was begun on March 20 and completed May 2. The 30 feet of strainer cost the contractors \$90. The price paid them for the well was \$456. The well being completed, the next procedure was to dig a pit deep enough to allow the pump to be submerged. The kind of pump decided on was a 4-inch vertical centrifugal, which

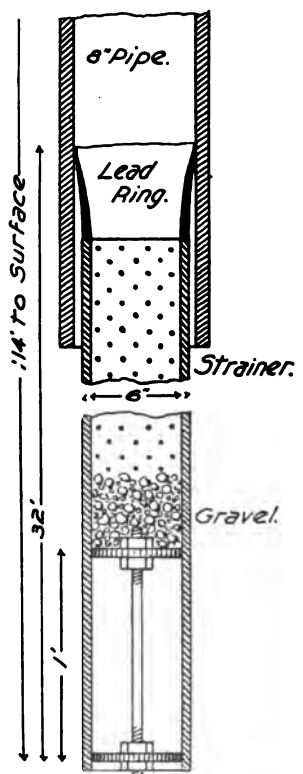

FIG. 70.—Method of making joint between strainer and well casing.

was placed in the bottom of a pit 30 feet deep and 6 feet square. The pit was curbed with 2-inch cypress, having corner posts made of 4 by 4 timbers. This was made up in four sections and was dropped into the pit as the digging progressed. It was possible for two men only to work in the pit, and during the first part of the digging two men were required for drawing the earth out with block and tackle. Heavy rains fell while the pit was being dug and the earth caved in, clamping the curbing so tightly that it was lowered with difficulty. When quicksand, at a depth of 27 feet, was struck the greatest difficulty was encountered. While this stratum did not contain a great amount of water, it rose from the bottom very rapidly. While it was hard to sink the shovel in the sand, it seemed to move upward very freely. It required about five days to lower the pit the last 3 feet. The curbing could not be moved any farther, being clamped by the sand, and it was necessary to make a sand box out of 1-inch lumber 3 feet deep, which was lowered to the bottom of the pit and driven with a sledge down into the sand.

This shut off some of the water which had made the digging so difficult. When the pit had been lowered to the joint in the pipe at 30 feet a large wooden clamp was placed just below the joint to support the pipe to which the pump was to be attached later. It was necessary to dig a small hole about 1 foot deep and about 2 by 3 feet to allow this clamp to be placed below the coupling of the pipe. It required fully a half day's digging to accomplish this. These difficulties have been encountered by the rice growers in Louisiana and Texas, in some cases it being impossible to dig the pits as low as desired.

One dollar and a half a day was paid for labor in digging until the quicksand was struck. After this it became necessary for the men to work in water and \$2 per day was paid. The lumber used in the curbing cost \$15 per 1,000 feet and the cost of the curbing was \$28.60. Boiler, engine, pump, and all accessories cost \$858.58.

After the pit was finished the upper 30 feet of pipe was removed. There was not room in the pit to use pipe wrenches, and it was necessary to cut the coupling with a cold chisel. This was done with great difficulty, as the water poured out into the bottom of the pit as soon as an opening was made. The top of the pipe was temporarily closed with a wooden plug. The suction pipe of the pump was 5 inches in diameter, and it was necessary to use a reducing fitting to make the connection between the pump and the 8-inch pipe. This had been attached to the pump on top of the ground and the whole was lowered into the well by block and tackle, ready to be attached to the well pipe as soon as the wooden plug was removed. In making this connection the water rushed out so that the men were working in water 4 feet deep before it was finished. It was then necessary to withdraw the water from the pit by means of buckets until the wooden framework to which the pump was to be bolted could be placed. This framework was made of oak timbers 4 by 6 inches and braced to the well curbing with 2 by 4 cypress timbers.

The vertical shafting was then placed in the pit, being supported by seven bearings attached to timbers spiked to the curbing. At the upper end the shafting carried a 10-inch pulley which received the power from the engine. Two bearings were placed close to the pulley at this point, one just above and one just below it, and an oak framework built at the top of the well supported these. The 10-inch pulley was placed low on the vertical shaft and an idler placed above the belt leading to the 10-inch pulley at an angle of about 45°. The idler could be adjusted to hold the belt down and to tighten it. The distance between the engine shaft and the vertical shaft was 16 feet. Forty feet of belting was used, and this was passed around the fly wheel (54 inches in diameter) and the 10-inch pulley. Had the belt been longer it would have been much easier to adjust. Two-ply belting 8 inches wide was used, and it is believed that had it been a little wider it would not have given so much trouble by stretching. Sixty inches of belt was taken out the first three days.

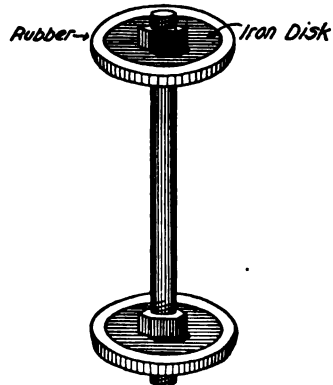

FIG. 71.—Disks for closing bottom of well casing.

The total lift of water was 29 feet. Theoretically it requires only about  $3\frac{1}{2}$  horsepower to lift 500 gallons of water per minute this height, but it was thought best to use a 12-horsepower engine, and this was ordered. The contract for the machinery included a guaranty that the 4-inch pump would raise 470 gallons per minute with the power and machinery furnished under a lift of 50 feet. It was not known what effect pumping would have on the water level, and an endeavor was made to provide ample power to raise the water, even should it be lowered to that depth. The contractors being anxious to have the machinery make a good showing, delivered an 18-horsepower engine, which has been used, although a 12-horsepower was preferred and would have been large enough. It is an 8 by 13 cylinder center-crank throttling engine. The fly wheel is 54 inches in diameter. With the first three days of pumping the engine was not run at as high speed as may be done later, on account of the stretching of the belt and of the necessary slight adjustments in the bearings of the vertical shaft from the pump. The average speed was 150 revolutions per minute, which would give to the pump 810 revolutions per minute, provided there was no slipping in the belt. The engine was placed on a foundation of 9 by 12 inch oak timbers. Two timbers 10 feet long were first placed on the ground and on top of these three short timbers 3 feet long were laid, then two timbers 7 feet long were laid lengthwise on these and the engine bed bolted through the entire framework. While this does not make as good a foundation as brick, stone, or cement, it has been found to be very good for the small engine used and was much less expensive.

Steam is furnished the engine by a 20-horsepower boiler, which is portable on skids, but has return flues, with smoke-box extension and a combustion chamber just behind the fire box. This approaches the condition of a stationary bricked-up boiler, but at the same time is portable and may be easily moved if at any time the experimental work should be given up and it become necessary to move the machinery elsewhere. Twenty feet of smokestack was used, which gives a strong draft. The boiler was fitted with two injectors, which draw water from the discharge of the pump for filling the boiler.

The complete pumping outfit was purchased from one firm, at a total cost of \$858.59. The items are as follows:

One 20-horsepower boiler, with smoke-box extension door and stack saddle, grate bars, bearing bars, bridge wall, fire-brick lining, pop safety-valve, steam gauge, siphon water column, glass water tube, gauge cocks, feed check, and blow-off valve, 2 Penberthy injectors, 20 feet smokestack, and 80 feet guy wire.

One 8 by 13 18-horsepower throttling center-crank engine, with 52-inch band wheel in place of square rim fly wheel, 36-inch band wheel, automatic governor, governor belt, throttle valve, oil cups, sight-feed cylinder lubricator, foundation bolts, oil can, and wrench.

One No. 4 vertical centrifugal pump, with upper half of coupling bored for 1½-inch shaft.

Thirty-five feet 1½-inch cold-rolled shafting.

One fitted flange shaft coupling.

Seven 1½-inch adjustable vertical boxes.

Forty feet 8-inch 4-ply Gandy belting, with 3 sets of fasteners.

Thirty-nine feet 4-inch black pipe.

One 4-inch coupling.

One 4-inch elbow.

Twenty feet 1½-inch pipe.

Four 1½-inch malleable elbows.

Ten feet 3-inch pipe.

Two 3-inch malleable elbows.

Seven close-pipe nipples.

One reducer, 8 inch to 5 inch.

One gallon cylinder oil.

One gallon lubricating oil.

In running the engine at a speed of about 150 revolutions per minute, the steam pressure was maintained at about 60 pounds. It was found that this was very easily done. Slack coal could have been purchased in Lonoke for \$1.90 per ton, but it was decided that it would be more economical to use a better grade of coal, and the experiment station purchased two carloads of hard coal, costing \$2.80 per ton.

Arrangements were made by the experiment station for the construction of a shed to protect the machinery. Since a very short belt was used, a shed 24 by 40 feet with 8-foot posts covered the well, as well as the engine and boiler. Galvanized-iron roofing was used. The total cost of the shed was \$95.

The well was placed about 60 feet from the edge of the rice field, on the highest side. The discharge pipe used on the pump was 4 inches in diameter, and an elbow was used at the top, with a short piece of pipe, from which the water was discharged into a pool about 10 feet in diameter. The water was then carried from this pool to the edge of the rice field by a small ditch, which was built slightly above the ground, with the earth removed from the pit. In this ditch a 1-foot Cipolletti weir was placed for measuring the water. When the water was discharged into the pool, it settled and passed into the weir flume with practically no velocity. The levee on the upper side of the rice field was only about 1 foot high. It was not only necessary to raise the water to the surface of the ground, but it had to be raised high enough to give about 1 foot fall for the weir and 1 foot fall where it passed over the levee into the rice field. This makes the lift slightly higher than would be necessary had not arrangements been made for measuring the water. A continuous record of the depth of water passing over the weir is kept by an automatic register.



No attempt has been made to ascertain just what effect the pumping has had on the water level by use of a vacuum gauge or other means, but since the pump is submerged  $3\frac{1}{2}$  feet it is known that the water level is not drafted down that much, for when the pump was first started it was stopped for just a few minutes many times in order to make some adjustments, and it was not necessary to prime the pump in starting again. It is not known whether the joint made between the pump and the well is water-tight or not, but the indications are that it is, for the first three days of pumping did not lower the water standing in the pit any perceptible amount. It is reasonable to suppose that the pumping did lower the water in the well a slight amount, and had there been any connection between the water in the pump and the water in the pit the same level would have been maintained in both.

Knowing the fatal results on account of insecure levees at the Morris farm, great care was taken in the construction of the levees about

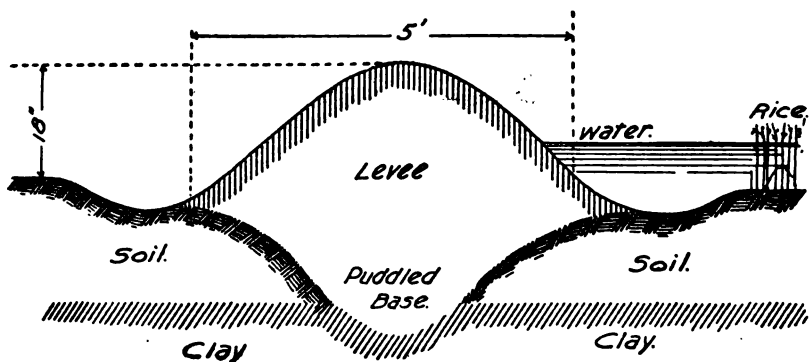

FIG. 72.—Section of field levee, Lonoke, Ark.

the rice field. The levees were placed about 5 feet in from the edge of the plowed ground. A trench about 8 inches deep was first made with a 16-inch plow, throwing the earth out in both directions. This trench extended to the clay which underlaid the soil. The earth was then thrown back into this trench and at the same time horses were ridden about the field on the levee to puddle it. (Fig. 72.) The levees were constructed when the ground was so wet that it was with great difficulty that the teams were driven through some of the lowest places. After the trench had been filled, the levees were thrown up by the use of the large plow and a crowder constructed of boards 2 inches thick and 12 inches wide. This machine was shaped like the letter A, having one side 10 feet long, which in using had a tendency to run in the direction the team was driven. The other side was only 4 feet long and was the one which crowded the earth up on the levee. The horses were kept going over the levee as the earth was thrown

up, which kept it well puddled, and the earth was packed down into the trench which was first dug. No trouble has been experienced with the levees. They have not broken, and practically no water has seeped through the bases of them.

The prairies about Lonoke are dotted with small mounds in many places, resembling very much the mounds found in the oil fields about Beaumont, Tex. These rise 1 to 2 feet above the level of the prairie, and at their base they are 10 to 75 feet in diameter. The rice field contained five of these mounds. One of the small levees through the middle of the fields dividing the different plats of rice was arranged so that it crossed two of the mounds, making it unnecessary for these to be removed. Two of the other mounds were removed by teams and scrapers, but the remaining one was left in order that it might be shown just what the result would be of raising rice without removing the mounds.

#### **PLANTING, WATERING, AND HARVESTING RICE.**

The work of the Arkansas Experiment Station in connection with the rice experiments was begun in February, when the sod was broken. Soon after this had been done, heavy rains came, and it was not until May 1 that the ground was again dry enough to be put in condition for the sowing of the rice. It was disked and cross disked, and then harrowed. The first sowing of rice was made with Japan seed on May 3, and included about 5.5 acres. Soon after this more heavy rain fell. The rainfall at Lonoke for February was 2.40 inches; March, 5.94 inches; April, 3.14 inches; May, 2.20 inches, and in June, up to and including the 23d, 7.12 inches. In planting the first rice a wheat drill was used. This was set for planting to a depth of less than 1 inch, but on examination it was found that most of the seed was placed more than 1 inch beneath the surface. Rains fell soon after the sowing was made, and when the ground dried out it baked and crusted over on top. Examinations were made from time to time to determine how the seed was germinating. It was found that only a small part of the seed sprouted at all, and many of these did not get through the crust on the surface. The small stems curled over and were not able to penetrate the crust, the result being that the stand was very poor. This was probably not due altogether to the deep planting and the crusty surface, for it is believed that the seed was too old.

On May 17 1 acre of Honduras rice was drilled, the drill being set to deposit the seed as near the surface as was possible. This seed was procured from Mr. Morris, who had raised it the year before on his farm near Carlisle. On May 23 1 acre was sown with what is commonly known as upland rice. This seed had been grown in small

patches by farmers in the vicinity of Lonoke, and was furnished by Mr. W. P. Fletcher. The seed resembles the Japan seed in size and shape. On May 20 1.05 acres of the ground which had been sown with Japan rice was disked, it being evident that the stand would not warrant any endeavor to raise the crop by irrigation. This plat was adjacent to the Honduras rice and was replanted with Honduras seed. The other 4 acres which had been sown with Japan rice were not disked, but 1 bushel per acre of new Japan seed was sown broadcast and harrowed in. This seed was also procured from Mr. Morris.

While the heavy rainfall throughout the spring up until the time of planting the rice had been a great disadvantage, it is probable that it was a great help in the sprouting of the rice later. The pumping plant was not ready for operation until June 23, but the 7.12 inches of rain which fell during the first twenty-three days of June was undoubtedly a great help in bringing the rice up.

Some of the best rice growers in Louisiana advise turning water on young rice for a short time only, when it should be turned off and fresh water put on. They claim that the ground should be kept moist, but that the tops should not be covered, and until the rice is 4 to 6 inches high water should not be left standing on it. After the first sowing of Japan rice had been replanted the stand obtained was satisfactory. From 1.25 to 1.5 bushels per acre had been sown where only one sowing was made.

On June 23, when the pump was first operated, all the rice was growing nicely. The earliest Honduras was about 10 inches high, the Upland about 6 inches high, and the later Honduras and the Japan rice about 4 inches high. The ground was still slightly moist when water was first turned on the field, and it had not at any time crushed over since the seed was planted.

One levee was run through the middle of the field, which separated the two plats of Honduras rice from the plats of Japan and Upland rice. Levels taken before the well was located indicated that the fall from the highest to the lowest corner of the rice field was 6 inches. This intermediate levee divided the field into two water levels, and had it not been for this it would have been necessary to cover the lower side of the field more than 6 inches deep in order that the upper side be kept moist. With the present arrangement, the greatest depth at any point on the field need be only slightly more than 3 inches to keep the entire field moist. The greater the fall in any field where flooding is necessary, the greater the amount of water required to cover it, and for this reason land should be very level for rice growing. If it is necessary to make a great many levees across a field, the space taken up by them will make a material deduction from the total area, and it is much more convenient to use teams in large compartments than in small ones. The levee through the middle of the

field was not made with the same precaution as the outer levee, but was made by throwing up two furrows with a 16-inch plow. If any water seeps through this levee from the upper side to the lower side it is not lost altogether.

The ditch from the pumping plant discharges the water on the upper side and the middle levee is cut to admit water to the lower side. The earliest rice is on the upper side, for it needs the water first, and water can be held on it for some time before it is turned onto the lower side of the field. Other things being equal, the early rice will need to be drained first, and after the pumping has been stopped the water can all be drained from the upper side, but held on the lower side as long as it is needed. In the fall, when the entire field is to be drained, it will only be necessary to cut the levee on the lower side, which will allow the water to run to a small stream only about one-half mile away, which will carry it to the bayou separating Prairie Longue from Grand Prairie.

After the pumping plant had been operated three days it was turned over to the Arkansas Experiment Station. It was placed in charge of Mr. G. E. Chase by Mr. W. G. Vincenheller, director. The entire area was covered in five days' pumping at ten hours per day. The following tables give the time of pumping, amount of water pumped, and the rainfall and evaporation during the season:

*Water pumped for rice irrigation at Lonoke, 1904.*

Day.	June.		July.		August.		September.	
	Hours pumping.	Gallons per minute.	Hours pumping.	Gallons per minute.	Hours pumping.	Gallons per minute.	Hours pumping.	Gallons per minute.
1								
2			7.50	432	3.00	496	9.00	435
3							6.00	414
4					7.50	467		
5			10.00	441	5.25	503		
6								
7								
8			4.00	411				
9			3.00	402				
10					8.50	442	7.00	402
11								
12								
13			6.50	547	8.50	385		
14								
15			3.00	451				
16			5.50	351			8.00	366
17					7.50	461		
18								
19								
20					7.00	466		
21					8.00	383		
22			3.50	505				
23	0.50	404	6.50	400				
24	7.25	390						
25	4.25	408			6.00	388		
26								
27	1.25	534						
28	4.25	443	7.50	459				
29	3.00	451						
30			8.00	386			6.00	259
31					9.00	387		
Total	19.50		72.00		63.25		36.00	
Average		438		438		428		356

## Rainfall and evaporation at Lonoke, 1904.

Week ending—	Rainfall.	Evapora- tion.	Week ending—	Rainfall.	Evapora- tion.
	<i>Feet.</i>	<i>Feet.</i>		<i>Feet.</i>	<i>Feet.</i>
June 29.....	0.1375	0.0131	September 1.....	0.1050	0.0371
July 7.....	.1738	.0184	September 8.....	.0041	.0271
July 14.....	.0800	.0304	September 15.....		.0336
July 21.....		.0357	September 22.....	.0291	.0251
July 28.....	.0200	.0385	September 29.....	.0125	.0311
August 4.....		.0358	September 30 <sup>a</sup> .....		.0051
August 11.....	.0366	.0367	Total.....	.7954	.4429
August 18.....	.0483	.0386			
August 25.....	.1025	.0659			

<sup>a</sup> One day.

The total volume of water pumped was 15 acre-feet, enough to cover 10 acres of the experimental plat to a depth of 1.5 feet. The rainfall for the season after pumping began was 0.8 foot, making a total depth of 2.3 feet of water received by the rice plats.

The yields are reported as follows by Mr. W. P. Fletcher, the owner of the land:

*Honduras rice.*—On the 16th day of May, 1904, 1½ bushels of Honduras rice were sowed with drill on 1 acre of ground. This rice was cut on the 4th day of October, 1904, and thrashed on the 16th day of November, 1904. The yield was 28 bushels per acre.

On the 30th day of May, 1904, 3½ bushels of Honduras rice were sown on 3 acres of land. This was cut on the 18th day of October, 1904. The water should have remained on all of the rice at least two weeks longer, especially on the late sowing. The last sowing of the Honduras rice was entirely too late. The water was taken off too early and the crop was not well filled, and on account of the thrasher being broken no portion of this rice was thrashed.

*Upland rice.*—On the 24th day of May, 1904, 1 bushel of upland rice (rice that is grown without water) was sown on 1 acre of land. One dozen bundles was thrashed and yielded 1 bushel. There were 52 dozen bundles upon the acre, making a yield of 52 bushels per acre. The greater portion of the upland rice was not well filled, which may be accounted for in two ways: (1) It was upland rice and not intended to have water applied, and (2) it was sown later than it should have been.

*Japan rice.*—On the 30th day of May, 1904, 4 bushels of Japan rice were sowed broadcast and disked in on 3 acres of land. This was cut on the 4th day of October, 1904, and thrashed on the 16th day of November, 1904. Two dozen bundles were thrashed and yielded 1½ bushels per dozen. There were 55 dozen bundles per acre. Estimating the yield of the Japan rice from the amount thrashed from the two dozen bundles the yield was 96½ bushels per acre, making a total of 288½ bushels of Japan rice from 3 acres.

There were only 8 acres in all sown. Three acres were not thrashed and 5 acres poorly thrashed and from actual measurements before the breaking of the machine and estimates made from them that were thrashed the yield was 323 bushels from the 5 acres, which would be equal to 64½ bushels per acre.

### OTHER PUMPING PLANTS USED FOR RICE IRRIGATION IN ARKANSAS IN 1904.

In addition to the experiment work at Lonoke, three other rice farms were operated in 1904. One was that of W. H. Fuller near Carlisle, another that of A. Boysen on the prairie near Wheatley, and another the Morris farm, where work was continued. (See pp. 560, 563.) These experiments were valuable to the public as well as the work at Lonoke, and information has been collected in regard to the cost and results of each.

#### THE MORRIS PLANT.

The work at the Morris farm during the past season was conducted by E. L. Morris, son of John Morris, who started the work two years before. Upon the return of W. H. Fuller from Louisiana with well-drilling machinery, Mr. Morris purchased one-half interest in the machinery and after first sinking a well for Mr. Fuller, moved the machinery to the Morris farm and put down another 10-inch well beside the old well in the same pit.

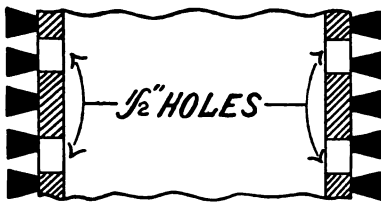

FIG. 73.—Section of strainer.

The 6-inch Morris centrifugal pump of horizontal type was then connected to both wells in an endeavor to increase the capacity of the plant. On these wells a Cook strainer was used. This is a brass strainer having slots beveled in such a manner that the opening is wider on the inside

of the pipe than on the outside, so that any particles which enter the slot at all easily pass into the well and either sink to the bottom or are drawn out by the pump. (Fig. 73.) The strainer used in this case has fine mesh, and as the wells were only 90 feet deep and as water was struck at 70 feet, the two wells had only 40 feet of strainer in all. It was found that no great advantage was gained by sinking the second well so near the old one, which indicates that the amount of water entering the well may be limited not only by the strainer itself but by the gravel around the strainer. It is also probable that had the additional 20 feet of strainer which the second well gave been placed at the bottom of the old well, making it penetrate the water-bearing stratum to a greater depth, the results would have been better, for in this case the pressure would be greater on the lower part of the strainer and the water level at the well would not be drawn down to a point so near the bottom of the strainer.

Fifty acres of rice were planted on the Morris farm in 1904, but only 25 acres were watered. This produced 1,790 bushels of very

plump rice, making 71.6 bushels per acre. It is impossible to learn the cost of the Morris pumping plant, but it is known that it was much greater than it need have been, and it has been shown that it is much cheaper in the end to construct a pumping plant with more care and forethought. The many expensive alterations that have been made would have been unnecessary had the plant been constructed properly in the first place, and it can never be made an efficient one.

#### THE FULLER PLANT.

Mr. W. H. Fuller, who, as has been before stated, determined to make rice growing a success, went to Crowley and Jennings, La., after the failure of the well near Carlisle, to get experience in rice culture. After spending four years there, he returned to his farm, bringing with him machinery and pipe for sinking 10-inch wells by the jet process. A test well of 3-inch pipe was first made, which struck the water-bearing stratum at a depth of 70 feet and penetrated entirely through it, reaching clay at a depth of 140 feet. Therefore Mr. Fuller decided to use 60 feet of strainer, which was to be set entirely in the water-bearing gravel. In this he used excellent judgment, for he is now able to get the greatest possible amount of water out of that stratum with one well. In the jet system it is necessary to decide on the amount of strainer to be used before the large pipe is started, for the strainer is first started in the ground and the joints of pipe attached to it as the well is lowered, instead of first sinking the pipe and dropping the strainer inside of it and then pulling the pipe back far enough to expose the strainer, as was done with the sand-pump process at Lonoke. In the latter case the strainer is said to be telescoped.

The jet process is a novel one. After the test well has been withdrawn, the first joint of the strainer is started rotating. Having an auger attached at its lower end, it penetrates the ground following the opening made by the test well. The accompanying sketch will show more clearly the method (fig. 74). A is the strainer, B is the auger attached to its lower end, C is the test pipe, which has now been placed inside of the strainer pipe, D is packing of chaff between the strainer pipe and the test well pipe, which keeps water out of the strainer. The auger at the bottom is slightly larger in diameter than the strainer, which leaves a small space outside of the strainer, marked E. The machinery not only keeps the pipes rotating, but by means of a force pump muddy water is constantly forced down through the test pipe and by means of a specially designed base the water passes up on the outside of the strainer, taking out the borings of the auger with it. During the entire process, a man is kept stirring mud into the water in a pool from which the

pump takes its supply. The rotation of the pipe may be stopped, but the muddy water is kept moving throughout the entire process, day and night, with no interruption other than is necessary to attach a new joint of test pipe. After all of the strainer is in the ground the well casing above it is attached, which, of course, requires no packing between it and the test pipe. When the well has been lowered to the desired depth, the test pipe is unscrewed at the bottom and, together with the chaff packing, is taken out, which completes the process. The auger can not be removed and a new one is required for each well made. A peculiar feature is a wooden ball valve at the bottom of the well, marked F, which allows the muddy water to pass downward to the auger, but as soon as the test pipe is withdrawn and the pressure of the muddy water released water and sand passing upward raise the wooden ball until it closes the opening permanently.

The strainer used on Mr. Fuller's well was made of ordinary casing by having slots sawed on the outside transversely to the length of the pipe. These slots, of course, are not beveled as those in the Cook strainer, and on account of the curvature of the pipe are slightly longer on the outside than on the inside. The slots are about 1 inch long and about 1 inch apart.

The water-bearing stratum, which seems to underlie the entire Arkansas prairie at about the same depth, was struck at a depth of 70 feet. This well is the only one that has penetrated deep enough to throw any light on the thickness of this stratum. It is the general belief that beneath the clay underlying it there is more water and that if wells were placed

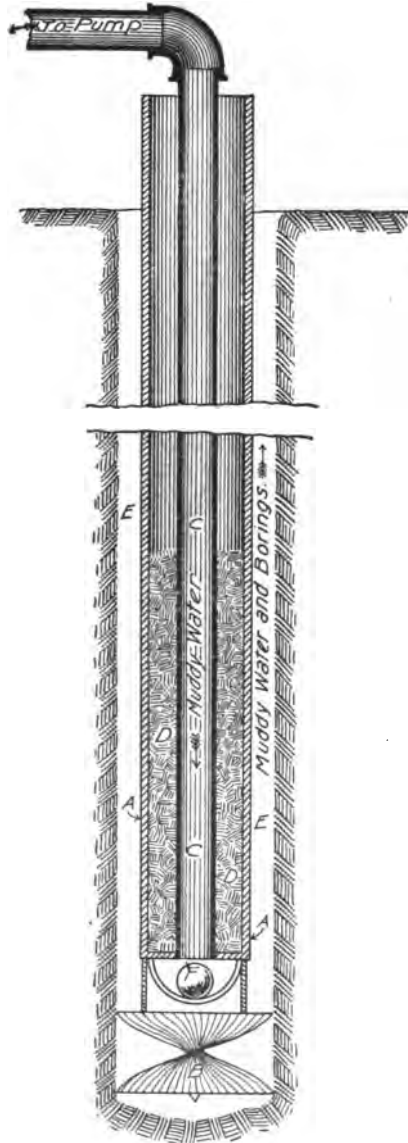

FIG. 74.—Jet process of sinking wells.



deep enough artesian water might be had. The lift at Mr. Fuller's plant is 27 feet, which is practically the same as the lift at the Lonoke plant. A pit 6 feet square was dug and curbed with 2-inch cypress lumber. No preparation had been made for securing a joint at a proper point to attach the pump, and the well casing was cut off with a cold chisel and a pipe coupling was heated at the bottom of the pit and was shrunken on to the top of the well casing to which the pump was secured. Meanwhile the water was exhausted by the force pump on the well-drilling apparatus. A 6-inch vertical centrifugal pump was used. It was the intention to submerge the pump 3 feet, but the shrinking of the coupling to the well casing was done under such great difficulties that the pump was submerged only 8 inches. Power was furnished by a 25-horsepower engine, commercial rating, and a stationary boiler of 35 horsepower, commercial rating. The following list gives the cost of the year's work:

*Cost of Fuller pumping plant.*

One 25-horsepower engine } -----	\$747. 00
One 35-horsepower boiler } -----	
3,500 bricks for setting boilers.....	35. 00
Fire brick for furnace.....	6. 40
Lime.....	4. 45
Hauling brick .....	17. 25
Repairs for boiler .....	3. 40
Shafting for pump.....	9. 75
One 6-inch centrifugal Kingford pump.....	140. 00
One belt and repairs.....	33. 80
Bolts.....	. 80
Hard oil .....	1. 50
Flue cleaner.....	1. 00
Lumber for shed boiler, etc.....	44. 00
Packing.....	1. 25
Teapot for cylinder oil .....	. 10
Pipes .....	. 50
Rods for boiler .....	3. 60
Hauling engine .....	20. 00
Repairs for boiler .....	2. 00
Engine oil.....	12. 00
One 10-inch well, 140 feet; 10-inch casing; 10-inch screen, 60 feet.....	630. 00
Coupling for well .....	11. 35
Bolts.....	. 50
Spikes .....	1. 50
Digging pit and setting pump.....	75. 00
One jet and pipe .....	14. 00
Rosin .....	1. 00
Two sticks belt dressing.....	1. 00
Plowing, harrowing, disking, and seeding 70 acres, at \$3.50 per acre .....	245. 00
140 bushels seed rice on 70 acres.....	140. 00

55 tons coal, at \$2.20 per ton.....	\$121.00
Hauling coal.....	55.00
Two shovels.....	1.85
Punchers for coal.....	1.75
35 cords wood, at \$2 per cord.....	70.00
Running pump for 70 acres, 50 days, 10 hours per day, 1 engineer and 1 levee tender.....	140.00
One rice binder.....	135.00
Harvesting.....	70.00
Shocking grain.....	40.00
Binder twine.....	33.00
Thrashing 5,225 bushels rice, by D. B. Perkins, at 3 cents..	156.75
Help in thrashing.....	120.00
<b>Total</b> .....	<b>3, 147.50</b>

Mr. Fuller sowed 9 acres of rice April 1, but was compelled to wait for a while on account of rains. The last sowing was made May 15. When the irrigation was begun, it took seventeen days and eleven nights to cover the entire 70 acres of rice which had been sown. After this it was not necessary to run the plant continuously. When running continuously it was found that if the pump stopped for a short time the water in the well was drawn below the pump and it was necessary to prime the pump in starting again, but if the pump was not started for several hours the water regained its original level, submerging the pump. The only measurement made on the discharge of this plant was a float measurement when the plant had just been started and while the steam pressure was yet low. This measurement indicated the discharge at that time to be about 750 gallons per minute, but it is believed that it exceeded 1,000 gallons per minute at other times. The 70 acres yielded 5,225 bushels of rice, being 74.6 bushels per acre.

**THE BOYSEN PLANT.**

A. Boyesen, who is a resident of Chicago, but a large owner of land in Arkansas, made preparations in the spring of 1904 for the growing of rice by irrigation. A pumping plant was constructed on his 3,500-acre ranch near Wheatley. A 10-inch well was sunk to a depth of 83 feet, on which 32 feet of second-hand Cook strainer was used. This strainer had been used by the Memphis Water Company, and was originally a very fine mesh, but became worn too much for use in fine sand. It was thought suitable for the coarser material found under the Arkansas prairies. The lower 43 feet of the well is in water-bearing sand, and the water rose to within 32 feet of the surface. A 6-inch vertical centrifugal Morris pump was used in a pit 6 by 6, curbed with 2-inch cypress lumber. Instead of the pump being attached directly to the top of the well pipe and

submerged it was attached to a 7-inch drop pipe 8 feet long. This pipe entered the top of the wall casing, leaving the pump 2 feet above the water level. The power was furnished by a rated 15-horsepower traction engine. The plant has not been efficient. When the engine was run at full speed the water in the well was drained to the bottom of the drop pipe, at which instant the discharge ceased, and the engine being relieved of work ran for a short time at very high speed; but as soon as the water level raised to the drop pipe the pump would again begin to work. It was therefore impossible to run the pump faster than about 500 revolutions per minute, which did not allow the water level to be drawn as far down as the lower end of the drop pipe. The result was that the discharge was only about 100 gallons per minute.

The digging of the pit cost \$50. The 10-inch well was made by Memphis well drillers. The man in charge of the well machinery was paid \$15 per day and an assistant was paid \$2 per day. In addition, the entire expense of bringing the drilling machinery and these men from Memphis and return was borne. The cost of the entire plant was \$1,850, of which \$100 was for the building.

An inexperienced engineer, who was employed to superintend the work, in addition to using bad judgment in the construction of the pumping plant, made an error in running levels and did not locate the well on the highest side of the rice field. This was not known until water was turned on the field, when it was found that 5 acres out of the total 17 which had been planted could not be irrigated. The 12 acres produced 1,068 bushels of rice, or 89 bushels per acre. This was Honduras rice, and the grain was finer in appearance than the seed rice which was purchased in New Orleans. There was no market for it in the locality and it is being fed to cattle and hogs. Mr. Boysen believes that even this use of it makes it a profitable crop. He also states that the yield of straw was about 6 tons to the acre, which the cattle seemed to eat as well as hay.

#### **DIVERSIFIED FARMING.**

It is the belief of many well acquainted with the situation that late vegetables grown by irrigation will in the long run be far more profitable than rice, as they think that the demand for rice will not increase as fast as the production and that the price will be lowered. Louisiana rice growers claim that in 1903 the supply was equal to the demand, if not greater, and many of them did not advocate any increased acreage in 1904. While it is believed that this condition of affairs will not come about as soon as is expected by many of the rice growers, it is certain that the farmers may realize as much from vegetables as from rice, provided the former can be grown success-

fully. Recently much interest has been taken in the growing of vegetables on the prairies. W. H. Vivion, who was one of the most energetic in the rice experiments at the Morris farm, expects to irrigate late vegetables from a small well on his fruit farm near Lonoke. He will use a small gasoline engine to pump water. C. V. Russell, a large cotton grower near Lonoke, also expects to make preparations for the irrigation of late vegetables this season. A great deal of interest is also being taken in the vicinity of Stuttgart 25 miles southeast of Lonoke. E. E. Sampson, of this locality, has purchased pumping machinery which he expects to install on Bayou Meto, to pump water for the irrigation of vegetables. The people here are particularly interested in drainage, and some of the wet prairie lands have been drained with great success.

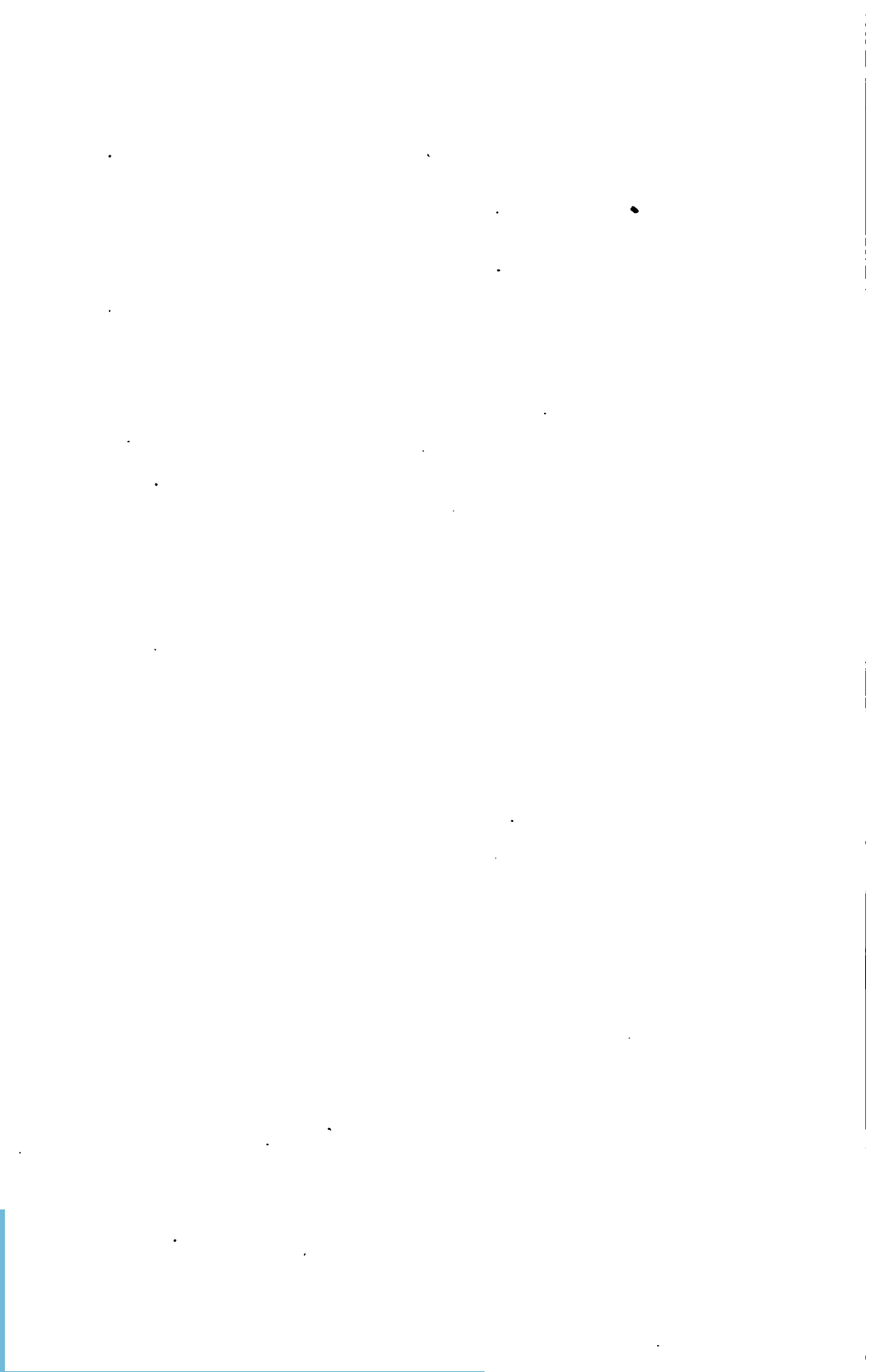

# IRRIGATION EXPERIMENTS AT FORT HAYS, KANS., 1903 AND 1904.

By J. G. HANEY,  
*Superintendent Fort Hays Substation.*

The experiments here reported were carried on at the Fort Hays Branch Experiment Station of the Kansas State Agricultural College in cooperation between the station and the irrigation and drainage investigations of the United States Department of Agriculture. The station is located at Hays, the county seat of Ellis County, Kans.

Fort Hays was established during the days of Indian troubles in the West, and for a long time was one of the most important of the western posts. In 1887 the further need of a military post was obviated by the removal of the Indians to Indian Territory, the troops were withdrawn, and the reservation and buildings were turned over to the Department of the Interior. The reservation comprised 7,500 acres of good land, and after much legislation it was ceded to the State of Kansas for the establishment of a western branch of its experiment station and a normal school. Work was begun on the experiment station in March, 1902.

The station is located between the ninety-ninth and one hundredth meridians, and about 150 miles east of the western line of the State. Conditions are therefore fairly representative of those in the semi-arid portion of the State. It is in a section where extensive irrigation from streams is impossible on account of the limited water supply. This station is therefore especially fitted for carrying on experiments to determine the possibilities and value of irrigation upon the semiarid plains where it must be supplemental to some other style of farming.

## **THE WORK OF 1903.**

The work was to be conducted by using the underground water, as the streams are usually dry when water is most needed. It is known in this section of the State that if shale beds are struck without finding water it is useless to go farther unless the shale is gone through. This may be from 200 to 500 feet.

The first prospect was made with a churn drill with a 6-inch bit. The location is about halfway up the rise from the creek bottom to the upland. Shale was found 30 feet from the surface and is overlaid with a thin stratum of sand, in which there is a small flow of

water. The hole was sunk 30 feet into the shale, which formed a basin, and the well furnishes enough water for a few head of stock.

At the second prospect, 500 feet north of the first, just at the edge of the creek bottom and 11 feet lower, shale was found at the same depth—30 feet—which shows that there is a dip toward the creek, which is 80 rods distant from the bottom well. Sand and rock were encountered at the second prospect 20 feet down, and contained an abundant flow of water. This was dug out 6 feet in diameter, and is used to furnish water for general use at the station.

Four other prospects were made in the vicinity and showed the same dip of shale. Two of these were also in the bottom, but farther from the stream, which has an easterly course at this point, and were dry; the two others, which would have made fair wells, were near the creek, and showed the shale to have a dip of about 10 feet in 500 toward the creek. One prospect was made on high land, nearly one-half mile from the creek. Shale was found at a depth of 47 feet, and no water at all.

A prospect was made one-half mile down the creek from the location of those mentioned. The creek at this place runs east for nearly half a mile, then south the same distance. The bottom here is wide and slopes toward the southeast. The best location for a well on this bottom would be at the upper northwest end, near the creek. Shale was found at a depth of 40 feet, but above this shale was about 14 feet of sand and gravel, much of which is very coarse. At this place the irrigation well was put down. However, another prospect was made here, 50 rods back from the creek, and nearly the same conditions found as at the first. A mile farther down the creek two prospects were made in a rather small bend near the bank, and very little water was found. The last prospect made was on the highest land on the station and nearly half a mile from the creek. Shale was found at 62 feet, and above it was found 10 feet of sand containing water. The prospector said he saw no reason why it would not be just as strong a flow of water as any found. In all, twelve prospects were made, only five of which showed strong flows of water, and it is doubtful if more than three of these would furnish water enough for irrigation purposes.

The irrigation well is located in the northwest corner of the northeast quarter of section 9 and near the creek. Excavation was begun April 11. The well is circular in form and 13 feet in diameter. As soon as necessary a hoist was arranged and operated with a traction engine.

The first water was struck at 24 feet in a layer of very fine sand and clay, nearly quicksand. Below this a hard stratum of dark gumbo was found. The water coming through the fine sand caused trouble immediately, as the soil above caved. The gumbo below the

sand was not solid enough to support a temporary wall, as was found after considerable work. A heavy curb was then built of 3-inch lumber by cutting the plank in segments and spiking them firmly. Four thicknesses were placed one on top of the other and spliced, so as to make the curb 18 inches thick. The inside diameter of the curb was 9.5 feet, which made the outside diameter 12.5 feet, so that it easily went into the well. The two lower courses of the curb were set in 3 inches, so that blocks of plank about 1 foot long and sharpened could be spiked against these and form a cutter around the curb, and as the blocks were sharpened from the inside the edge of the cutter was flush with the outside of the curb. This curb was lowered and set and an 18-inch wall of rock laid on it. The stone was carefully dressed, wedge shaped, and chinked with spalls, as there was a great deal of pressure against the wall. After a few courses of rock were laid sand and mud were taken from the inside of the curb, which allowed it to settle, and as it settled more stone was laid on top.

As soon as the flow of water began to bother, a Knowles pump with a 14-inch discharge and 5-inch suction was set in a frame suspended from the top and later set on a plank laid on the wall and raised when necessary.

After the fine sand and gumbo were passed, the wall was sunk in clean sand and gravel to shale, which was 16 feet below where the curb was set. For the last 5 feet the water gave a great deal of trouble, and it was necessary to get another boiler to supply the steam for the pump.

The superintendent of the Union Pacific Railway water service estimated at the time that the pump was throwing 22,000 gallons per hour. The flow of water brought in a great deal of sand, and it was necessary to take out perhaps several times the volume of the well. This also made it necessary to fill in behind the wall after shale was reached. The wall was built of stone to a point above the water and cave, then finished with brick.

The water rises 16 feet in the well, or within 24 feet of the surface. Just under the surface of the water two 8 by 10 inch timbers were laid in the wall across the well to support the pump. Timbers were also put in at intervals of 7 feet above the water to support the shaft, as the vertical style of pump is used. The pump, a 4-inch vertical centrifugal, is hung in a frame 4 feet below the surface of the water. This insures the pump being primed when starting, and it doubtless would be an advantage to have the pump even lower. The frame at the top of the well is built very strong, as the pull of the engine is against the shaft. The pump is operated with the traction engine, and the regular thrasher belt used.



**COST OF WELL.**

A detailed statement of the cost of the well is given below. While it may appear that the cost is quite high, it is believed to be very nearly what a well of this kind under the same conditions may be expected to cost. At the beginning it was not known what would be encountered in putting it down. There is no doubt, however, that another well could be put down at less cost, now that the conditions are understood. The superintendent of the work was a former employee of the Union Pacific Railroad water service and was paid \$3 per day; engineers, diggers, and masons, \$2, and common helpers, \$1.50 per day. The following are the items of expense:

*Cost of well.*

Labor of digging, walling, etc.....		\$398.42
Use of engine, 19½ days, at \$3.....		58.50
Coal for engine, ½ ton per day at \$6.....		58.50
11.8 cords of stone, at \$9.25.....		109.15
2,500 brick, at \$13.25 per 1,000.....		33.12
4 sacks cement, at \$1.05.....		4.20
	Feet.	
3 by 15 plank used in curb.....	608	
Two 8 by 10 12-foot.....	160	
Nine 6 by 6 12-foot.....	324	
Two 8 by 8 16-foot.....	170	
Boxing for pump.....	100	
Total .....	1,362, at \$30 per 1,000..	40.86
Team, 4 days' grading.....		10.00
200 feet of 1-inch rope.....		13.00
2 barrels.....		2.00
Blacksmith work.....		15.00
4-inch centrifugal pump, complete.....		115.37
Freight on pump.....		7.53
Total .....		865.65

**THE IRRIGATION FIELD.**

The field in which the irrigation plats are located was broken in May, 1902. No crop was grown on the sod and it was not plowed again until March, 1903. The plows were then run deeper than the breakers had gone and the land was packed and harrowed immediately afterwards. As the spring was cold and wet and the work generally delayed, the ground became very weedy and was again plowed, packed, and harrowed before planting in May.

The plats, nine in number, were laid out to secure the most uniform slope from the well. They contain 2 acres each and are 60 rods long, with an alley dividing them cross-wise at the middle. The well is at

the northwest corner and the plats extend southeast from the well. Only the north half of each plat is irrigated, the south half being given the same treatment in every other respect.

The soil is a dark loam with enough sand to make it work nicely, but not enough to make any trouble from seepage. As indicated in the digging of the well, the soil has the same color and appearance in every respect from the surface to water. Beginning about 5 feet from the surface and extending 3 or 4 feet farther, a dry stratum is found. The soil is harder here than above or below, but not different in other respects.

#### CROPS, 1903.

The planting was much later than it should have been, the potatoes being planted May 18-26, and the corn and beets at the same time. But the ground was in good condition and everything started nicely. The Kaw Valley Early Ohio seed potatoes were very poor in quality, largely owing to the lateness of the season. Cabbage was not planted until June 22. All planting was done in the ordinary manner and ordinary cultivation was given the crops. On July 10 it began to appear that the crops needed water, so the pump was started.

A 1-foot weir was used in measuring the water pumped, and, as it had been made for some time and was not properly set, it gave considerable trouble and prevented getting an accurate record. The crops were given one irrigation, the water being run down each space between the rows, but the soil had been thrown up against the row so that the plants were not submerged. It was found to be a great advantage to have the furrow well cleared for the water to run in, or the upper ends of the rows would become too wet.

The fall in the field is 1.5 feet to 30 rods, which appears to be about right. By having the furrows well cleared, and running the full flow of the pump into one furrow, the water will run the full length of the plat in 30 minutes and will wet the soil very nicely between rows. The amount of water taken up by the soil would greatly surprise the beginner. By running the water down every other furrow (rows  $3\frac{1}{2}$  feet apart) 2.5 inches is required—that is, the amount of water required would cover the whole plat 2.5 inches deep.

#### COST OF IRRIGATION.

There are various changes that will be made in the plant used that will increase its efficiency. The total lift of water when the pump is taking the full capacity of the well is 42 feet. The average flow, as registered by the weir, and which was low on account of leaks, is 0.52 cubic foot per second. The discharge would equal 4.96 acre-inches in ten hours. The engine, a 12-horsepower traction, consumed an average of 113 pounds of coal per hour. The coal used is

from the Leavenworth mines and is of very poor quality. The plant requires an engine and one man to attend the water.

Only one irrigation of the crops was made, from July 11 to 24, and a total of ninety-nine and one-half hours' pumping was required to cover 7 acres, including all the crops mentioned in the tables. This, at the average rate of discharge of the pump, covered 7 acres to a depth of 7.33 inches, or 51.31 acre-inches, with an average lift of 42 feet.

With coal at \$6 per ton, engine at \$2 per day, and water tender at \$1.50 per day, it makes the cost of water for these items, delivered on one field, \$1.41 per acre-inch, or \$10.34 per acre, for the quantity used, but with the improvements that will be made, this cost can, without doubt, be considerably reduced.

When the water in the well is at its highest point, which submerges the pump 4 feet, there is a total lift of only 28 feet. The discharge of the pump is practically double what it is at a lift of 42 feet. This would reduce the cost to one-half if the water would hold at its highest, which shows the advantage of shallow wells and the disadvantage of deep ones.

It may be said in justice to the subject that the work done should hardly be considered as fully representing the possibilities. The season was unusually rainy, the land new, the seeding late, and no previous expenditure had been made. The work will be carried on from year to year and it is expected that the results will be more satisfactory.

#### RAINFALL AND EVAPORATION.

A rain gauge and evaporation tank were kept in the field. The former was the Government type, and the latter consisted of a galvanized-iron tank, 3 feet deep and 3 feet in diameter, set in the ground so that the top of the tank was a few inches above the surface. This was kept filled with water to within 6 or 8 inches from the top, and measurements were made every week.

The following table gives the rainfall and evaporation by periods from the beginning of the crop's growing to the first killing frost, May 25 to September 13:

*Rainfall and evaporation at Hays, Kans., May 26 to September 5, 1903.*

Period.	Rainfall.	Evapora- tion.	Period.	Rainfall.	Evapora- tion.
	<i>Inches.</i>	<i>Inches.</i>		<i>Inches.</i>	<i>Inches.</i>
May 26-30 .....	8.87	0.396	July 25-August 1 .....	2.27	1.044
May 30-June 6 .....	.25	.324	August 1-8 .....	.00	1.236
June 6-13 .....	.25	1.500	August 8-16 .....	1.74	2.136
June 13-20 .....	1.64	.636	August 16-22 .....	1.64	2.952
June 20-27 .....	1.70	.720	August 22-30 .....	.32	1.208
June 27-July 4 .....	.00	1.980	August 30-September 5 .....	.18	1.464
July 4-11 .....	.03	2.160			
July 11-18 .....	.23	1.200	Total .....	14.07	20.684
July 18-25 .....	.00	1.728			

The following table shows yield per acre of irrigated and nonirrigated potatoes:

*Yield per acre of irrigated and nonirrigated potatoes.*

Variety.	Width between rows.	Yield per acre.			Gain by irrigation.		
		Large.	Small.	Total.	Large.	Small.	Per cent. <sup>a</sup>
	<i>Inches.</i>	<i>Bushels.</i>	<i>Bushels.</i>	<i>Bushels.</i>	<i>Bushels.</i>	<i>Bushels.</i>	
Burbank, irrigated.....	36	63.92	41.25	105.17	37.26	14.08	15
Burbank, not irrigated.....	36	26.66	27.22	53.88			
Kaw Valley, Ohio, irrigated.....	36	30.83	37.22	77.05	21.98	6.52	50
Kaw Valley, Ohio, not irrigated.....	36	17.85	30.70	48.55			
Kaw Valley, Ohio, irrigated.....	30	49.51	32.63	82.16	30.86	4.31	75
Kaw Valley, Ohio, not irrigated.....	80	18.65	28.32	46.99			

<sup>a</sup> Based on total yield.

While the yield was low, the results of irrigation are very marked. The low yield can be attributed to the late planting, as there was not a large number of potatoes in a hill. Also, the land being new, did not admit of best results. The potatoes were sold in the open market for prices ranging from 50 to 65 cents per bushel for the large ones and about 10 cents less per bushel for the small ones. Calling the average price 55 cents per bushel for large and 45 cents for small potatoes, the increased value due to irrigation was \$26.92, \$15.02, and \$18.91 per acre, respectively, for the plats given in the preceding table. The cost of irrigation (see p. 572) was \$10.34 per acre. If the cost of the plant is charged to the 7 acres irrigated, this will amount to \$123.66 per acre. Interest on this at 6 per cent is \$7.42, and a similar charge for depreciation brings the entire annual cost of irrigation up to \$25.18 per acre, just about equal to the value of the largest increased yield reported.

*Yield per acre of irrigated and nonirrigated mangel-wurzels.*

Irrigated .....	pounds..	42, 100
Nonirrigated .....	do.....	31, 200
Gain due to irrigation.....	do.....	10, 900
Gain due to irrigation.....	per cent..	35

Cabbage was irrigated twice, July 10 and 23.

*Effect of irrigation on cabbage as compared with that not irrigated.*

	"Sure head."	
	Irrigated.	Not irrigated.
Total plants.....	456	456
Number of good heads.....	195	94
Second-grade heads.....	141	111
Average weight per head.....	pounds.. 2.88	2.27
Plants not producing heads.....	120	251
Percentage of plants not producing heads.....	per cent.. 26.5	55

The following table shows yield of varieties of corn, irrigated, not irrigated, and gain resulting from irrigation:

*Yield of varieties of irrigated and nonirrigated corn, and gain resulting from irrigation.*

Variety.	Yield per acre.		Gain per acre due to irrigation.	
	Irrigated.	Not irrigated.		
	<i>Bushels.</i>	<i>Bushels.</i>	<i>Bushels.</i>	<i>Per cent.</i>
Smith Center Yellow.....	45.14	37.14	8	22
Minnesota No. 13.....	34.66	27.14	7.52	26
Colorado Yellow No. 1.....	23.52	20.47	3.05	15
Australian White No. 2.....	38.17	27.83	10.34	35
Colorado No. 3.....	35.94	27.83	8.11	29

While it is not expected that corn will be a crop that it will pay to irrigate, it is important to know whether irrigation will prevent the damage done by hot winds.

### THE WORK OF 1904.

The irrigation of growing crops in this section necessarily comes at a time when labor is high priced, owing to the great demand for harvest hands. Hence the work this year included winter irrigation, as during the winter and early spring it is much less expensive to apply water. Also, in case the supply is taken from streams water can be used which usually goes to waste.

The planting of the plats was planned so that each crop would be included in the test of winter and summer irrigation. Winter irrigation was to consist of giving the land one good wetting before plowing in the spring and no subsequent irrigation. Summer irrigation was to consist of irrigating the crops when it appeared that they needed moisture.

The preparation of the land was such as would be given any field by a thoroughly practical farmer. The plats are laid out so that the irrigated and not irrigated parts receive identically the same treatment except the application of water to the irrigated part. The land being new it was plowed only an inch or so deeper than previously, or 6 or 7 inches. The plats planted to sugar beets were subsoiled 6 to 8 inches deeper than the plowing and the subsoiler run in each furrow behind the plow.

There is no doubt that previous treatment will affect crops. Hence the following table is given to show what was previously grown on the various plats. The land was broken in 1902 and bore no crops previous to 1903.

*Previous use of experimental plats.*

Plat.	1903 crop.	Treatment, 1903.	1904 crop.
1	Potatoes .....	One-half irrigated; <sup>a</sup> ground plowed after potatoes were dug.	Sugar beets, winter irrigation.
2	Potatoes, west one-half; cabbage, east one-half.	One-half irrigated, potato ground plowed afterwards; cabbage ground not.	Sugar beets, summer irrigation.
3	Corn .....	One-half irrigated.....	Potatoes, winter irrigation.
4	do .....	do .....	Potatoes, summer irrigation.
5	Kafir, west one-half; sorghum, east one-half.	Not irrigated.....	Kafir corn, west one-half winter and east one-half summer irrigation. <sup>b</sup>
6	Soy beans and cowpeas ...	One-half irrigated.....	Sorghum, west one-half winter, east one-half summer irrigation.
7	Mangels and sugar beets..	Very poor stand secured; ground plowed and harrowed in July.	Corn, west one-half winter and east one-half summer irrigation.
8	Corn .....	One-half irrigated.....	Potatoes, no irrigation.
9	do .....	do .....	West one-half potatoes, no irrigation; east one-half pencillaria, one-half irrigation.

<sup>a</sup> Irrigated half is always north half of plat.  
<sup>b</sup> Refers to east or west half of north half of plat.

**CHANGES IN PUMPING PLANT.**

Several changes were made in the pumping plant which increased its efficiency: (1) It was possible to lower the discharge pipe 2 feet by resetting the weir, and (2) the well being on the bank of a creek having running water in it nearly the whole year, a pipe was put from near the level of the water in the creek through the bank into the well. A dam was then built across the creek, raising the water about 3.5 feet above the regular level of the water in the well. The 6-inch pipe put through the bank was 30 feet long and had a fall of about 2 feet in that distance. The pipe nearly supplied the capacity of the pump at a lift of 28 to 30 feet. At starting the water would be 3.5 feet above the ground-water level, and the pump would lower this 4 or 6 feet. The weir reading showed about 1 cubic foot per second at this lift.

Between the pumping for the winter irrigation in April and that for the summer irrigation the dam went out, and another was built which did not raise the water so high by a foot. This decrease in head allowed the pump to lower the water several feet below the level of the former head maintained, and showed a decrease in discharge of approximately 0.1 cubic foot, or gave the pump a discharge of 0.9 cubic foot per second.

The cost of winter irrigation, with the 3.5 foot head of water to supply the pump, was approximately 75 cents per acre-inch, delivered on the field. In thirty-two hours 33.9 acre-inches were pumped. Fuel and labor cost the same as in 1903—that is, coal, \$6 per ton; engineer, \$2 per day; water tender, \$1.50 per day. In 1903 the lift was 42 feet, and the cost was \$1.41 per acre-inch, as against 30-foot

lift the present season and a cost of 75 cents per acre-inch. For the first twelve hours of pumping the pump did not discharge its full capacity, as it was windy, the belt slipped, and other difficulties were encountered. During one period of thirteen hours' pumping during the winter irrigation water cost but 68 cents per acre-inch, delivered on the field.

But one irrigation was given the plats for summer irrigation. This required twenty-eight hours' pumping, during which period 28.14 acre-inches were pumped, at a cost of 81 cents per acre-inch, delivered on the field. The increase in cost over the winter irrigation is due to having 1 foot less head of water, which allowed the pump to lower the level in the well 4 to 6 feet below the level held during winter irrigation.

The following table compares the three periods of pumping. Coal cost, \$6 per ton; engineer, \$2 per day; water tender, \$1.50 per day. The lift is only an approximation, as the level varied from time to time.

*Cost of pumping water.*

	1908.	1904.	
		Winter irrigation.	Summer irrigation.
Hours pumped .....	99.5	32	28
Coal burned ..... pounds..	12,600	4,900	4,400
Lift .....	40-42	28-30	34-36
Approximate rate of discharge per second .. cubic feet..	.52	1.07	1.01
Water pumped .....	51.31	33.90	28.14
Cost per acre-inch .....	\$1.41	\$0.75	\$0.81
Coal per acre-inch .....	245	144	156

#### WINTER IRRIGATION.

Checks were made with a ridger, 4 feet apart and the long way of the plats, and water turned into several of these at a time. As soon as water had reached the opposite end of the plat it was turned back and the flow shut off.

The ridger was made of two 4 by 6 pieces, 4 feet long, bolted in a V shape, with an opening about 4 feet at one end and 8 inches at the other. A plate of heavy strap iron was bolted on the inner lower edges of the sides to protect them from wear. The ridger was drawn with the wide end forward, so that the dirt scraped up by the two sides made an even ridge as it passed out at the back or narrow opening. The plats to be irrigated were all treated alike, and as soon as dry enough they were plowed, the land packed and harrowed. If it was not possible to plow the plat as soon as in condition, a harrow was put on to restore a soil mulch.

The variation in the amount of water which the plats seem to have taken was perhaps due to stopping the pump for noon or night on

one plat before it was finished, and not on all. If the stop was made when the water was but part way over it, it would be necessary to run over the wet portion again after the first water had been taken up. Whether the ground had been fall plowed also made a difference in the amount of water taken, as is seen by comparing plats 1 and 3. Plat 1, having been in potatoes, was fall plowed, while No. 3, being in corn, was not fall plowed.

The alfalfa that was irrigated was sown the year previous and is not a very good stand. The cutting of weeds, etc., of the previous year was left on the field, which made it difficult to run the water over it. This doubtless accounts for the large amount put on. However, there is no doubt that the effect of this one irrigation will show for a number of years.

#### SUMMER IRRIGATION.

The crops were given a good cultivation and made a good, vigorous growth from the beginning. It will be noticed that while the rainfall during May and June was not abundant, it was very evenly distributed and kept all crops growing nicely. While the potatoes and beets did not seem to suffer, it was noticed that they did not appear quite so thrifty as on the winter-irrigated plats, and it is probable that an irrigation about June 15 would have been a great help.

Irrigation was begun June 28, and after one hour pumping work was stopped by one of the hardest, heaviest rains of the season. Harvest began immediately after this attempted irrigation and it was July 26 before the work could be resumed. In the meantime the potato crop was practically matured and subsequent watering would doubtless have been detrimental. At this time it could be distinctly noticed that the winter-irrigated plats were in the best condition. The corn, Kafir corn, and sorghum on the winter-watered plats had made a growth of 8 inches to 1 foot more than on the other plats. The period of cultivation was practically over, but the soil had not been ridged up along the rows. To clear the rows for irrigation, a flat, broad shovel (duck-foot) was put on a cultivator and run between the rows. This made a good opening for the water and kept it away from the plants. The crops all shaded the ground, so no further cultivation was given.

All the plats responded very readily to the watering, soon showing an improvement over the winter-irrigated ones.



### CULTIVATION AND WEATHER.

These features have been mentioned at other places, but not specifically. The cultivation began as soon as the land was plowed. The plows were followed with the subsurface packer, and this with a harrow. The crops were planted immediately after the plowing and soil mulch maintained by use of the harrow and weeder until the crops were too large for these tools. The plats of sugar beets did not receive this treatment after they were up, as the plants are too tender, but as soon as possible the spring-tooth cultivator was used.

After the other crops were too large for the harrow or weeder, the small-shoveled, 4-gang cultivator was used as often as necessary to keep the weeds down and the soil in good condition. This required a cultivation after every rain that formed a crust to any extent.

The sugar beets were given one cultivation before thinning. The seed was planted very thick and when the plants had about four leaves they were thinned to one plant to every 6 inches and at the same time all weeds were removed. It was necessary to hoe the beets once after thinning, as they spread widely and the weeds can not be taken out of the row.

The weather has also been spoken of as being generally favorable, but there is no doubt that there was a slight deficit in the rainfall throughout the season. By reference to the following table it will be seen that the rainfall for April, May, June, and July—the four growing months—was but 10.53 inches for the entire period, and previous to this period there had been very little rain for months. However, the very even distribution of the rains and the absence of any long dry periods gave the crops a chance to make full use of all the moisture that fell.

### RAINFALL AND EVAPORATION.

Observations of rainfall and evaporation were conducted on the irrigation field similar to those of 1903. (See p. 572.) The rain gauge and large evaporation tank were set at the northwest corner of the field. Measurements were taken once each week throughout the period from April 28 to October 29. These are given in the accompanying table, as are also notes on the general weather of the period.

*Weather conditions at Hays, Kans., 1904.*

Date.	Rainfall.	Evapo- ration.	Wind.	Weather.
	<i>Feet.</i>	<i>Feet.</i>		
April 28-May 8	0.247	0.182	Southeast	Cloudy, moderate.
May 8-14	.000	.218	North	Mild, bright
May 14-21	.018	.116	South to south- east.	Partly cloudy, mild.
May 21-28	.011	.088	East to south- east.	Partly cloudy, warmer.
May 28-June 4	.064	.069	Northwest	Showery, mild.
June 4-11	.015	.089	South	Less cloudy, fogs and mist.
June 11-18	.055	.098	Southeast	Warmer, partly cloudy.
June 18-25	.066	.117	South, east	Showers, warm.
June 25-July 2	.163	.036	East, south	Stormy, warm.
July 2-9	.038	.081	do	Showers, cooler.
July 9-16	.003	.151	South	Clear, warmer
July 16-23	.053	.104	South, east	Clear, hot days.
July 23-30	.010	.182	Southeast	Windy, cooler.
July 30-August 6	.108	.064	East, southeast	Clearer, mild.
August 6-13	.022	.105	do	Clear, warmer.
August 13-20	.147	.056	East	Cloudy, wet, warm.
August 20-27	.002	.149	Southeast	Clearer, warm.
August 27-September 3	.000	.035	Northwest	Clear, cooler.
September 3-10	.000	.111	West	Clear, moderate.
September 10-17	.111	.111	East, southeast	Partly cloudy, warm.
September 17-24	.005	.082	East, south	Partly cloudy.
September 24-October 1	.084	.070	South to south- east.	Showery, cooler.
October 1-8	.000	.072	South, east	Partly cloudy, moderate.
October 8-16	.007	.102	South	Threatening, moderate.
October 16-22	.004	.065	Northwest	Partly cloudy, cooler.
October 22-29	.000	.066	West to north- west.	Clear, moderate.
Total	1.144	2.619		

NOTE.—From January 1 to April 28, 1904, the total rainfall was 0.049 foot.

**CROPS AND RESULTS.**

The crops irrigated were sugar beets, Burbank and Early Ohio potatoes, Black-hull white Kafir corn, Colman sorghum, Kellogg's Pride of Saline corn, Pearl millet (or pencillaria), and alfalfa. It may be said that all the crops responded favorably to the irrigation.

The beets, Kafir corn, sorghum, and pencillaria were planted in drills 21 inches apart. The potato seed was cut but little and dropped one seed in a hill 18 inches apart, the rows being 30 inches apart. The corn was planted on the surface, one stalk in a hill, 16 inches apart, width of rows being 36 inches. The sorghum, Kafir corn, and pencillaria were cut with a corn harvester, the corn husked from the shock, sorted into good, marketable ears and nubbins and weighed. The fodder was likewise weighed. The heads were cut from the Kafir corn, sorghum, and pencillaria, thrashed, and weighed. The heads were weighed before thrashing also, so as to obtain full weight of fodder and grain. The potatoes were dug in the usual manner and sorted into an extra-good market class and second grade. The beets were pulled, topped, and weighed; then put in a root house. Samples of the beets were sent to the chemical department of the Kansas Agricultural College and the Greeley Sugar Company, of Greeley, Colo., for analysis. The results of these analyses follow.

*By Agricultural College, Manhattan, Kans.*

	Average weight.	Sugar in juice.	Coefficient of purity.
Winter irrigated .....	Pounds. 2.79	Per cent. 13.91	Per cent. 78.1
Summer irrigated .....	2.25	12.71	79.4
No irrigation .....	1.86	14.15	79.8

*By the Greeley Sugar Company, Greeley, Colo.*

	Number of beets.	Average weight.	Sugar in juice.	Sugar in beets.	Purity.
Winter irrigated:		Ounces.	Per cent.	Per cent.	Per cent.
Large .....	.5	67.59	14	12.60	78.5
Small .....	5	23.60	15	13.50	77.7
Summer irrigated:					
Large .....	5	70.40	13.4	12.06	75.2
Small .....	5	28.16	14.8	13.30	79.5
No irrigation:					
Large .....	5	42.94	13.8	12.40	77
Small .....	5	19.71	15.5	13.95	82

Accompanying the Greeley Sugar Company's report on the analysis was a letter from the manager of the plant, from which the following extract is taken :

The results show that none of the beets were ripe. We divided each lot into two samples—large and small—so that you might see how much more preferable an average-sized beet is for sugar than a very large one. We claim that the maximum size for a good sugar beet is 3 pounds, while the average ones come nearer 1.5 pounds. The small beets of the not irrigated sample were the only ones of the whole lot that could be termed of commercial value, and even they were not good enough to be very encouraging from a manufacturer's point of view.

We would judge from the general appearance of the beets, they being somewhat stubby and a large proportion having grown above ground, that the soil had been prepared to as great a depth (10 to 12 inches) as we find necessary to give the best results.

Thus it would seem that the beets were oversize and green at taking the sample; but they usually would have time to fully mature before heavy frost. Owing to long distance from factory the freight rates prohibit shipping the beets. The yields of beets are shown in the following table:

*Sugar beets.*

Acreage.	Season.	Irrigated.				Not irrigated		Gain due to irrigation.	
		Date watered.	Water applied.	Yield per acre.	Sugar test.	Yield per acre.	Sugar test.	Tons.	Per cent.
1	Winter .....	Apr. 12	Inches. 5.70	Tons. 16.52	Per cent. 13.91	Tons. 14.14	Per cent. 14.15	Tons. 2.38	Per cent. 16.83
1	Summer .....	July 26	5.31	19.57	12.71	14.36	14.15	5.21	36.28

POTATOES.

The potatoes are of very fine quality, and command a price over the stock shipped in from irrigated districts. The yield might have been increased by planting thicker on the irrigated plat, but this would have interfered with determining the effect of using water. It has been the intention throughout these experiments that only the addition of water should be responsible for any variation in yield. The following table gives the yields of potatoes:

*Yields of potatoes.*

BURBANK.

Acreage.	Season.	Date watered.	Irrigated.				Not irrigated.			Gain due to irrigation.			
			Water applied.	First grade.	Second grade.	Total.	First grade.	Second grade.	Total.	First grade.	Second grade.	Total.	
	Winter....	Apr. 12-13...	In. 3.83	Bush. 71.06	Bush. 25.76	Bush. 96.84	Bush. 49.24	Bush. 24.52	Bush. 73.76	Bush. 21.84	Bush. 1.24	Tons. 23.08	P. ct. 31.29
	Summer...	June 28.....	1.01	53.94	25.50	79.44	34.54	23.52	58.06	19.40	1.98	21.38	36.82

KAW VALLEY OHIO.

	Winter....	Apr. 12-13...	3.83	57.34	49.12	106.46	30.84	34.74	65.58	26.50	14.38	40.88	62.33
	Summer...	June 28.....	1.01	50.04	24.24	74.28	31.56	31.16	62.72	18.48	-6.92	11.56	18.43

The potatoes sold for the same prices as in 1903, 50 to 60 cents per bushel for large, and 40 to 55 cents per bushel for small ones. Taking average prices of 55 and 45 cents per bushel for the two grades, computing interest and depreciation as in 1903, at \$14.84 per acre, and taking the cost of pumping as given on page 576, gives the following statement of the financial results from the irrigation of potatoes:

*Comparative statement of cost of irrigation and crop returns.*

Kind.	Value of increased yield due to irrigation.	Cost of water.		
		Interest and depreciation.	Pumping, etc.	Total.
Winter irrigated (Burbank).....	\$12.57	\$14.84	\$2.87	\$17.71
Summer irrigated (Burbank).....	11.56	14.84	.82	15.87
Winter irrigated (Kaw Valley Ohio).....	21.05	14.84	2.87	17.71
Summer irrigated (Kaw Valley Ohio).....	7.05	14.84	.82	15.66

The table shows quite largely increased yields due to irrigation, but in one case only is this increase large enough to repay the cost of delivering the water on the field. The cost of delivering the water was \$8.61 greater than the value of the increased yield due to the

summer irrigation of the Kaw Valley Ohio potatoes, and \$5.14 and \$4.10 greater, respectively, for the winter irrigated and the summer irrigated Burbanks. In case of the winter irrigated Kaw Valley Ohio variety, the value of the increased yield was \$3.34 greater than the cost of delivering the water; but this should not be looked upon as a net profit due to irrigation, for to the cost of delivering the water should be added the expense of checking the land in preparation for the application of the water, and, also, the extra expense of digging and marketing the larger crop of potatoes. It is hardly fair, however, to charge the entire cost of plant to the 7 acres irrigated, as the pumping of water enough for this tract requires but a few hours, and the same equipment would serve a much larger area. The cost of raising water is also much greater than the average reported from other places. The experiments show that irrigation makes a large increase in yields, but the cost is excessive. It is possible that this cost can be reduced to come well within the value of increased yields, leaving a good margin of profit from irrigation.

## OTHER CROPS.

The following tables show the results of experiments with other crops:

*Yields of Kafir corn, sorghum, and Pencillaria.*

## KAFIR CORN.

Acre age.	Season.	Date watered.	Irrigated.				Not irrigated, yield per acre.		Gain due to irrigation.			
			Water applied.	Yield per acre.			Seed.	Fodder.	Gain due to irrigation.			
				Seed.	Fodder.	Yield per acre.			Seed.	Fodder.	Seed.	Fodder.
↓	Winter.....	April 13-15.	In.	Bush.	Tons.	Bush.	Tons.	Bush.	Per ct.	Tons.	Per ct.	
↓	Summer.....	July 27.....	4.02	42.86	3.02	44.64	1.72	-1.78	-3.98	1.90	75.50	
				35.36	4.50	19.64	1.72	15.72	80.04	2.78	161.60	

## SORGHUM (COLMAN).

↓	Winter.....	April 15.....	3.04	35.36	7.18	32.86	2.69	2.50	7.60	4.49	165.9
↓	Summer.....	July 27.....	5.54	40	7.53	35.70	2.69	4.80	12.04	4.84	179.9

## PENCILLARIA.

↓	Summer.....	July 29.....	2.34	14.08	4.78	7.78	3.38	7.8	93.8	1.4	41.42
---	-------------	--------------	------	-------	------	------	------	-----	------	-----	-------

*Yield of corn (Kellogg's Pride of Salina).*

Acre age.	Season.	Date watered.	Water applied.	Irrigated.					Not irrigated.	
				Yield per acre.					Yield per acre.	
				First grade.	Second grade.	Total feed.	Total fodder.	First grade.	Second grade.	
↓	Winter....	April 15-16.	Inches.	Bushels.	Bushels.	Bushels.	Tons.	Bushels.	Bushels.	
↓	Summer...	July 26.....	5.38	46.28	5.14	51.42	1.71	41.58	5.70	
			4.54	53.42	5.72	59.14	1.77	37.42	5.70	

Yield of corn (Kellogg's Pride of Salina)—Continued.

Acre- age.	Total.		Not irrigated.				Total gain due to irrigation.			
			Corn.		Fodder.		Corn.		Fodder.	
	Seed.	Fod- der.	First grade.	Second grade.	First grade.	Second grade.				
	<i>Bushels.</i>	<i>Tons.</i>	<i>Bushels.</i>	<i>Bushels.</i>	<i>Tons.</i>	<i>Tons.</i>	<i>Bushels.</i>	<i>Per cent.</i>	<i>Tons.</i>	<i>Per cent.</i>
1	47.28	0.80	4.70	0.56	.....	.....	4.14	8.75	0.91	113.7
1	43.12	.80	16	.02	.....	.....	16.02	37.15	.97	121.2

Yield of alfalfa.

Acre- age.	Season.	Irrigated.			Not irri- gated. yield per acre.	Gain due to irri- gation.	
		Date watered.	Water applied.	Yield per acre.		<i>Tons.</i>	<i>Per cent.</i>
1	Winter.....	April 16-18.	<i>Inches.</i> 16.9	<i>Tons.</i> 3.40	<i>Tons.</i> 2.60	<i>Tons.</i> 0.80	<i>Per cent.</i> 30.74
1	Summer.....	July 27-29..	13.6	3.04	2.76	.28	10.14

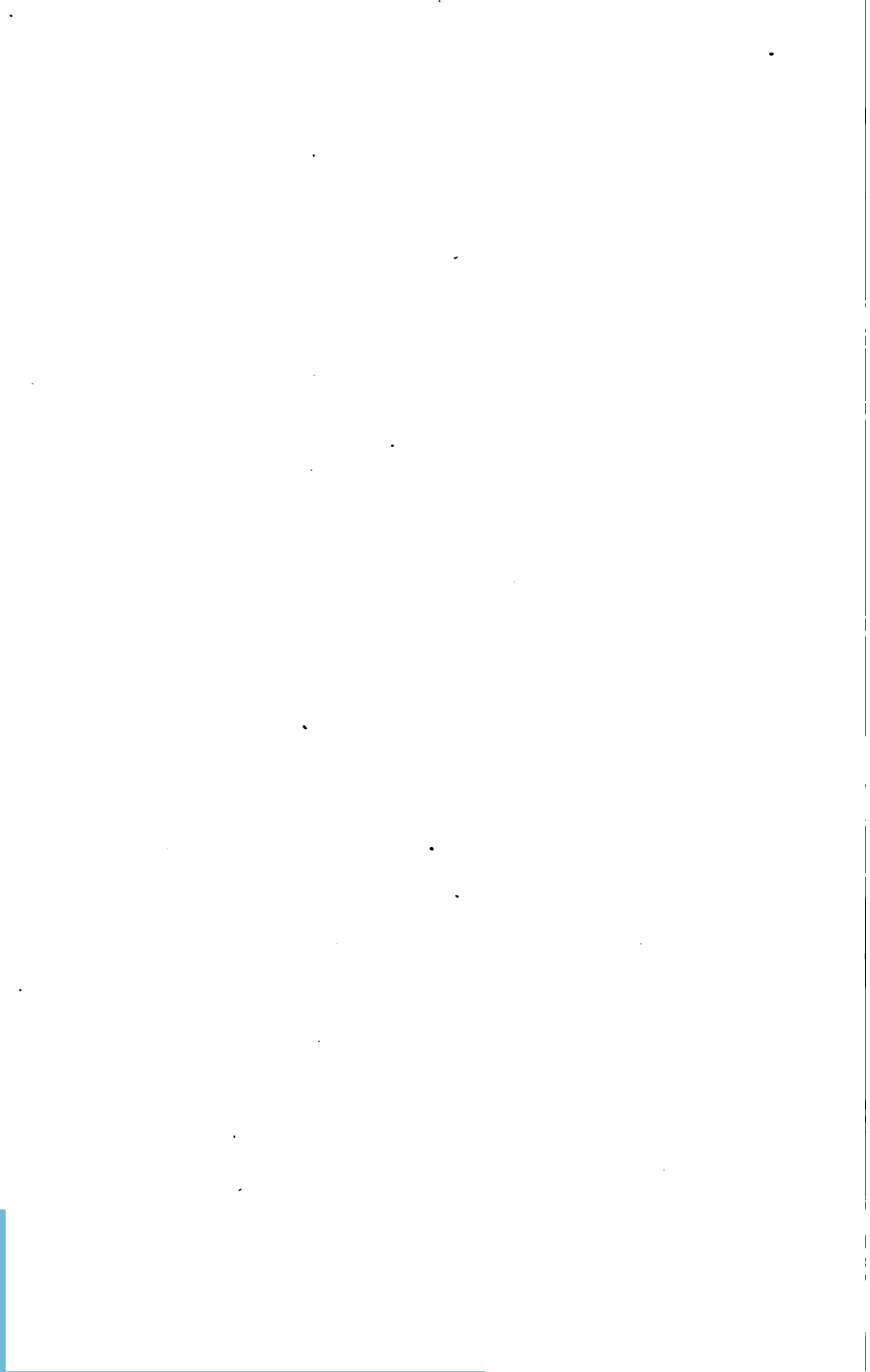

# IRRIGATION NEAR GARDEN CITY, KANS., 1904.

By A. E. WRIGHT and A. B. COLLINS,

*Agents and Experts, Irrigation and Drainage Investigations.*

## INTRODUCTORY.

The valley of the Arkansas River at Garden City, Kans., is divided into two distinct flats or levels, each with a natural slope of about 7 feet per mile in an easterly direction, or in the same general direction and with the same average slope as the river bed. The lowland, or first bottom, as it is termed, extends from one-fourth to one-half mile on either side of the river, and is devoted wholly to the raising of hay, as during periods of exceptionally high water it is completely flooded. The higher flat, or second bottom, on the north side of the river, owing to its uniform slope and the general character of the soil, is particularly adaptable to irrigation. From a point about 3 miles west of Garden City to a point about 5 miles east, where the sand hills on the south and the bluffs on the north suddenly close to within a half mile, this second bottom is entirely covered by the Garden City ditch and its laterals, which are owned and controlled by citizens of Garden City. The ditch was originally planned to irrigate 6,000 acres, but owing to an injudicious use of water in irrigation, seepage, and evaporation, and to losses due to poor construction and equally poor maintenance, the maximum irrigating capacity of the system has been only about 3,000 acres, and even this was possible only during periods of exceptionally high water in the Arkansas River. As the supply of water from the river is not to be depended upon, a large number of windmills are used to raise water for irrigation, and in several instances small centrifugal pumps and gasoline engines have been installed for this purpose. The areas irrigated in this manner are not large, yet in view of the uncertainty of water supply from other sources, to irrigate the smaller areas by individual pumping plants and to specialize crops are economic lines along which the most successful results can be obtained. Opposed to this, the citizens of Garden City advocate the combination of the water brought to the surface by pumps or by gravity and its discharge into and distribution through the ditches already established. Of the two methods of obtaining water a gravity system is perhaps the more strongly advocated. Numerous engineers have been consulted regarding the feasibility and probable cost of such development, and the opinions advanced have been as varied as the methods proposed for bringing the water to the surface.



### THE APPARENT SUPPLY OF UNDERGROUND WATER.

That the so-called "underflow" is enormous in this district is unquestionable, but to what extent it can be drawn on without having to wait for a replenishing of the affected area is a question that can be decided only by a practical test. In such plants as are in operation it is impossible to affect materially the supply, and continuous pumping adds to rather than detracts from the efficiency of the wells.

The surface of the ground waters in this region is a plane with a slope to the east of 7 feet to the mile. The river bed has the same general direction and slope, but the underground waters do not appear to depend at all on the water conditions of the river, except that continued high water produces a slight rise in the ground level. Following the receding of the river the surface of the ground water gradually assumes its normal level, and continued stages of low water or times when the river is dry do not affect it.

The yearly contribution to the supply by precipitation alone must necessarily be great. The catchment area is large, and with a rainfall of about 20 inches per year draining into this water-bearing stratum the supply would appear to be inexhaustible. Observations made of the water supply in established pumping stations sustain this assumption.

The largest plant in this vicinity is the one from which the city is supplied with water. Here a 20-foot circular well was dug and curbed with brick and cement work, and from the bottom of this a 12-inch perforated iron feeder was sunk to the depth of 20 feet. This single feeder furnishes 500,000 gallons of water per pumping day of sixteen hours. During this pumping the water in the main well is lowered about 15 feet, but at this point the water supplied by the single feeder becomes equal to the demand and a further lowering at this rate of pumping is impossible. Several times, however, through forced pumping the water has been pumped beyond the capacity of the feeder, and the consequent lowering of water has exposed the action of the feeder, which, with all pressure removed from above, becomes practically an artesian well. Measurements by Mr. Willard Johnson during one of these periods gives the discharge of the feeder at 900 gallons per minute.

At the Richter well, 1.5 miles west of Garden City, a 12-foot circular sheet-iron casing was sunk to a depth of 16 feet, and from the bottom of this four perforated feeders, three 6-inch and one 12-inch, were sunk to a depth of 14 feet. Measurements of the water level were taken during a pumping test of an hour and forty-five minutes on September 3, 1904. At 10 o'clock a. m. the water level was 9.2 feet below the top of the casing. This level is counted the normal. The measurements are as follows.

*Changes in the water level in the Richter well during pumping.*

Time.	Depth.	Time.	Depth.	Time.	Depth.	Time.	Depth.
<i>Feet.</i>		<i>Feet.</i>		<i>Feet.</i>		<i>Feet.</i>	
10.00 a. m.-----	9.2	10.07 a. m.-----	13.2	10.14 a. m.-----	14.2	10.25 a. m.-----	14.4
10.01 a. m.-----	10	10.08 a. m.-----	13.5	10.15 a. m.-----	14.3	10.30 a. m.-----	14.4
10.02 a. m.-----	10.9	10.09 a. m.-----	13.7	10.16 a. m.-----	14.4	10.45 a. m.-----	14.4
10.03 a. m.-----	11.7	10.10 a. m.-----	13.8	10.17 a. m.-----	14.4	11.00 a. m.-----	14.4
10.04 a. m.-----	12.4	10.11 a. m.-----	13.9	10.18 a. m.-----	14.4	11.15 a. m.-----	14.4
10.05 a. m.-----	12.8	10.12 a. m.-----	14	10.19 a. m.-----	14.4	11.30 a. m.-----	14.4
10.06 a. m.-----	13	10.13 a. m.-----	14.1	10.20 a. m.-----	14.4	11.45 a. m.-----	14.4

This well is equipped with 10-horsepower gasoline engine and a pitless pump of 800 gallons capacity per minute. Owing to general disorder of the engine and to the rotting away of the wooden casing surrounding the pump, the efficiency of the plant was low, only 405 gallons per minute being pumped during this test. Reliable authority states that after an eight-hour test of this well, during which time 800 gallons per minute was pumped, 16.6 feet below the surface was the greatest depth to which the water was lowered.

In the tests of the Richter well the uniformity of the results obtained is due to the continued pumping. This well is one of the oldest in the valley, and from long and continued use the water, its head varying with the amount of water pumped, has, in following the lines of least resistance, opened up new channels that have in time been drained of the finer material and the velocity of the flow has greatly increased. A comparison of the test of the Richter well and the following tests taken at King Brothers well, 8 miles northwest of Garden City, August 30, 1904, shows a decided difference in the velocities with which the water enters the wells.

The following notes were taken at the first pumping of the King Brothers well:

A 4-inch centrifugal pump was set at the water level, 40 feet below the surface of the ground. The arrangement of idlers and the shaft bearing would not allow continuous pumping without too great a heating of the parts; and the measurements, therefore, are not so satisfactory as it is probable later ones will be. The measurements following were taken in two wells—the main well, which was 91 feet deep and from which the water was pumped, and the test well, 87 feet deep and placed 25 feet south. A distance from the surface of 42.2 feet was taken as the normal level. The first test began at 11.05 a. m.

*Changes in the water level in the King Brothers well during first pumping test.*

Time.	Depth in main well.	Depth in test well.	Time.	Depth in main well.	Depth in test well.
	<i>Feet.</i>	<i>Feet.</i>		<i>Feet.</i>	<i>Feet.</i>
11.05 a. m. ....	42.2	42.2	11.12 a. m. ....	60	45
11.06 a. m. ....	49.2	42.2	11.13 a. m. <sup>a</sup> .....	50	45
11.07 a. m. ....	53.7	43.1	11.14 a. m. ....	46.6	44.6
11.08 a. m. ....	59.6	43.5	11.18 a. m. ....	45.6	44.4
11.09 a. m. ....	59.8	44.8	11.20 a. m. ....	43.8	44
11.10 a. m. ....	60	44.9	11.25 a. m. ....	43	44
11.11 a. m. ....	60	44.9			

<sup>a</sup>Pumping ceased.

The second test began at 2.15 p. m. The water in the well had not at this time reached its previous height, and the water level was 43 feet below the surface. The following table shows the results of pumping:

*Changes in the water level in the King Brothers well during second pumping test.*

Time.	Depth in main well.	Depth in test well.	Time.	Depth in main well.	Depth in test well.
	<i>Feet.</i>	<i>Feet.</i>		<i>Feet.</i>	<i>Feet.</i>
2.15 a. m. ....	43	43	2.27 a. m. ....	58.8	43.9
2.16 a. m. ....	52.5	43	2.28 a. m. ....	59.9	43.9
2.17 a. m. ....	55	43.4	2.29 a. m. ....	60	42.9
2.18 a. m. ....	57.2	43.7	2.30 a. m. ....	60	43.9
2.19 a. m. ....	58.5	43.9	2.31 a. m. ....	60	43.9
2.20 a. m. ....	59	43.9	2.32 a. m. ....	60	43.9
2.21 a. m. ....	58.8	43.9	2.33 a. m. ....	60	43.9
2.22 a. m. ....	58.8	43.9	2.34 a. m. ....	59.7	43.9
2.23 a. m. ....	58.8	43.9	2.35 a. m. ....	59.7	43.9
2.24 a. m. ....	58.8	43.9	2.36 a. m. ....	59.7	43.9
2.25 a. m. ....	58.8	43.9	2.37 a. m. ....	59.7	43.9
2.26 a. m. ....	58.8	43.9			

During this pumping an even discharge of 175 gallons per minute was attained, except when the water, under increased head, brought into the feeder a quantity of very fine sand. There was sufficient pressure to raise this to the suction pipe, and the discharge of the pump when throwing a large percentage of sand was materially diminished. At three different times during this pumping this condition was noticeable, but with continued pumping it became less pronounced, and in time this finer material will be drawn off within the circle of influence developed by the well to such an extent that the water will flow into the well with a greater velocity and will be entirely free from the finer sand. In other words, the efficiency of these feeders sunk to within a foot or 18 inches of the impermeable bed of silt that underlies the valley increases rather than diminishes with use. This bed of river silt being uneven, in a great number of cases the feeders in the plants in operation have not reached its depth. It has been found that the supply of water in feeders that do not reach this depth is much less than in those that do, and that the increase in water supply with increased depth of feeders is far greater proportionately than the increase in depth.

**WINDMILL IRRIGATION NEAR GARDEN CITY.**

Thirty-one windmill plants were visited<sup>a</sup> and measurements taken of the size of mills, reservoirs, land irrigated, and water applied. As it is not possible to determine the duty of a mill directly from an observation of the amount pumped without in some way measuring the velocity of the wind, the method of getting at the duty of a mill and the duty of an acre-foot of water was to question the irrigator as to the time required to fill the reservoir in a good wind, the average number of times per week that the reservoir is filled through the season, and the number of reservoirs of water usually applied to any specified piece of land. There are several serious elements of error in this sort of data. The time for one filling was in most cases given in days or half days. The depth drawn off from a reservoir was in nearly every case reported greater than the total vertical distance between the bottom of the outlet and the top of the bank. Notwithstanding these sources of error, it is believed that the data as collected show approximately enough for practical use by those contemplating windmill irrigation what one can reasonably expect to do with a mill of a given size with moderate lift. The data on the duty of water are believed to be a reliable average for single irrigations. The number of applications varies greatly with the season.

Nearly all of the pumps used are of the design known as the "Stone" pump, made in Garden. This is a piston pump made in large sizes, from 6 to 12 inches in diameter, and is used with a stroke of 6 to 12 inches. It is customary to use a pump the size of which in inches is 2 less than the diameter of the windmill in feet—that is, a 6-inch pump is used with an 8-foot mill, etc. In most cases the stroke of the mill is adjusted to 10 or 12 inches. As it is not possible to make a study of the efficiency of these pumps without disconnecting them from the mills, in this report only the diameter of the mills is considered, disregarding the leakage and efficiency of the various pumps.

In giving the duty of windmills of various sizes the number of acre-feet per day pumped by each mill in a "good wind" is given and also the number of acre-feet in a season (twenty weeks), which is estimated from statements made by irrigators as to the average amount pumped. In many cases mills of two sizes were used to pump water into a single reservoir. In such cases the amount pumped by each mill is assumed to be in proportion to the surface exposed by each wheel to the wind. The data regarding the 31 windmills observed are condensed in the table following.

---

<sup>a</sup> By Mr. Wright.

*Average duty of windmills.*

	Lift.	Amount pumped per day.	Amount pumped in season (20 weeks).	Area irrigated.
	<i>Feet.</i>	<i>Acre-feet.</i>	<i>Acre-feet.</i>	<i>Acres.</i>
Six 8-foot mills.....	13	0.08	3.4	2.1
Eleven 10-foot mills.....	14	.17	7	4.1
Thirteen 12-foot mills.....	14	.27	11.7	5.7
One 25-foot mill.....	12	1.20	54	8

It is evident that the surface exposed by a windmill to the wind varies as the square of the diameter and it is reasonable to expect that the amount of work done will vary in the same ratio. The above table shows, however, that there is a very marked increase in the amount of work done by the larger mills. For instance, an 8-foot mill raises 3.4 acre-feet in a season, so that one would expect to find that a 12-foot mill would raise  $9/4$  times 3.4, or 7.6 acre-feet, but as a matter of fact the 12-foot mills averaged 11.7.

The area irrigated by a single mill does not seem to bear any definite ratio to the amount pumped in a season. This is due to the fact that many of the plants covering small areas are shut down a good part of the season, which is not taken account of in the estimates of the amount pumped in a season.

It is probable that all of the mills falling below the average given above do so because of leakage or lack of care or poor exposure to the wind. The following table is made by throwing out all mills which fall below the average, and is probably a better measure of the duty of mills than the table given above:

*Duty of windmills pumping more than the average.*

	Lift.	Amount pumped per day.	Amount pumped in season (20 weeks).
	<i>Feet.</i>	<i>Acre-feet.</i>	<i>Acre-feet.</i>
Three 8-foot mills.....	13	0.09	4
Four 10-foot mills.....	14	.26	11.5
Eight 12-foot mills.....	14	.34	14.4

In order to determine the number of acres which can be irrigated by an average windmill plant it is necessary to ascertain first the duty of water. This was found to vary much in different cases. The depth applied at a single irrigation on 89 acres of fruit trees averaged 0.23 foot; on 17 acres of beets, 0.49 foot; on 26 acres of sweet potatoes, 0.22 foot; and on 44 acres of garden vegetables, 0.29 foot. The average single irrigation on all crops is 0.27 foot in depth. The number of irrigations is variously reported as from 2 to 7. It is not possible, however, to estimate closely from such data what the duty of water would be in a dry year, as the rainfall in

1904 was quite sufficient for some crops (such as alfalfa) and nearly sufficient for all. It is probable that a depth of 1.5 feet would be sufficient in any except extremely dry years. Using this as a basis, it is fair to say that an 8-foot mill should irrigate 2.5 acres, a 10-foot mill nearly 8 acres, and a 12-foot mill nearly 10 acres, the season being considered as twenty weeks. The heaviest winds during the irrigating season are in May and June. During July and August many plants do very little work for days at a time, so that the number of acres which can be irrigated, if dependent on the duty of a mill during July and August, may be somewhat less. The actual number of acres irrigated is far smaller than the above estimates, being 2.1 for an 8-foot mill, 4.1 for a 10-foot mill, and 5.7 for a 12-foot mill.

#### COST OF WINDMILL PLANTS.

The first cost of putting land under water by a windmill plant is much less today than it has been heretofore, on account of the strong competition between various manufacturers and the lower cost of transportation. For this reason the cost of plants as reported by the owners is much greater than the present cost in many cases.

The cost of a complete plant put up near Garden City is about as follows, the cost including mill, tower, pump, and well:

12-foot .....	\$135
10-foot .....	100
8-foot .....	75

The cost of a number of plants observed was:

12-foot .....	\$150
10-foot .....	120
8-foot .....	90

The above estimates do not include the cost of reservoirs. The average cost of a large number was given as about \$60, which includes in most cases the cost of lining the banks with sod or puddling the sides and bottom with cattle. In many reservoirs the leakage is so great that the efficiency of the plant is seriously reduced. A loss of 2 to 6 inches per day is not uncommon. Proper construction and, if necessary, the use of clay as a puddle should reduce leakage to not more than, say, 1 inch per day, which is more than the loss from many plants.

The cost per acre irrigated ranges from about \$20 to \$75 or \$80. The higher cost is found in plants irrigating much less than their capacity. For instance, a two-mill plant, costing \$280, is used on 4 acres of sweet potatoes, while it should water at least 10 acres.

The following data regarding other windmills near Garden City were collected by Mr. Collins.

Windmill plants near Garden City, Kans.

No.	Owner.	Size of mill.		Depth to water.	Depth in water.	Total.	Tank or reservoir.	Irrigating head.	Area irrigated.	Year erected.	Cost per acre per year.
		Feet.	In.								
1	Robert Jonson	8	6	11	26	37	30 by 30	2.5	2	1900	\$2.50
2	Sam Austin	10	8	13	23	36	50 by 50	2.5	3	1901 1894	2.00 2.00
3	Frank Penington	12	4	13	23	36	50-barrel tank			1902	2.00
4	J. I. Pierce	12	6	11	22	33	70 by 50	3	4.50	1897	2.00
5	Ed Pyle	12	6	10.5	20	29	50 by 50	3	2.50	1892	2.00
6	Shep Norris	8	6	12	20	28	40 by 70	3.5	1	1900	3.00
7	B. F. Stocks	8	6	10	21	31	40 by 70	3.5	4	1892	1.50
8	O. V. Fulsom	12	10	10	32	42	60 by 65	3.5	4	1892	2.00
9	J. C. Kitchen	10	8	13	22	35	120 by 70	2	2.50	1902	3.50
10	N. F. Weeks	12	8	13	22	35	75 by 85	3	5	1894	6.00
11	Ed Pyle	8	6	11	19	30	50 by 50	1.8	1.50	1890	.....
12	R. L. McConahay	8	6	10	11	21	50 by 50	1.8	1.50	1896	2.00
13	Ed Pyle	8	4	11	19	30	40 by 40	1.4	1.50	1900	1.75
14	R. L. Hoslet	8	6	10	12	22	15 by 35	2	1	1902	1.00
15	J. Bondurant	8	4	11	18	29	20 by 30	2.5	.50	.....	.....
16	W. B. George	10	6	10	21	31	50 by 20	2	.50	1900	2.50
17	W. J. Green	8	6	10	20	30	50-barrel tank		.50	1900	2.50
18	G. W. Worden	6	6	11	20	30	30 by 30	3	2.75	1900	1.50
19	G. D. Lathrop	6	5	11	20	31	20 by 35	3	2.50	.....	.....
20	N. C. Jones	10	4	11	14	25	20 by 15	1.8	1.25	1903	.....
21	H. S. Bosworth	10	5				20 by 20	1.6		.....	.....
22	G. A. Ferguson	10	1.5			130				.....	.....
23	R. P. Hoover	6	4	10	25	35	12 by 20	2.5	1	1903	.....
24	W. R. Hopkins	8	6	9	20	29	30 by 30	2.5	.75	1902	1.75
25	W. O. Carter	10	6	4	17	21	35 by 35	3	2	1901	6.00
26	P. M. Bowser	8	6	10	20	30	30 by 50	3	1.75	1900	1.25
27	W. A. Pierce	8	4	10	16	26	20 by 20	2.5	.50	1899	1.50
28	Frank McCune	8	4	8.5	20	28.5	18 by 18	1.8	1.50	.....	4.00
29	W. E. Truell	8	6	8.5	18	26.5	20 by 20	1.7	.50	.....	.....
30	W. J. Covert	8	6	8.5			30 by 25	2	1	.....	.....
31	Will Holmes	10	6	7.5	11	19.5	12 by 16	2	.75	1901	2.00
32	John Cooper	10	6	8	18	25.5	12 by 18	1.8	1.50	1903	.75
33	Mrs. Edwards	6	6	8	9	17	50 by 50	2	5	1899	4.00
34	Mrs. Baird	10	6	8	10	18	20 by 20	1.5	.50	1900	3.00
35	Jay Brown	8	6	8.5	18	26.5	45 by 40	2	1.25	1900	4.00
36	O. W. Finch	8	6	8	16	24	35 by 50	3	2.25	1902	1.50
37	Zeph Roberts	8	4	8.5	15	23.5	Tank		.50	.....	.....
38	N. Jonson	8	3	8	20	28	20 by 12	1.8	.50	1903	.....
39	Dan Felcher	8	4	9.5	20	29.5	Tank		.50	.....	.....
40	Mrs. Calahan	10	6	9			50 by 20	3	2	1900	1.50
41	Court-house	8	6	9.5	28	37.5	Tank		1	.....	.....
42	W. R. Peterson	10	4	11			30 by 30	2.5	.75	1902	1.50
43	L. V. Smith	8	6	10	22	32				.....	.....
44	do	8	4	8.5					.50	.....	.....
45	W. W. Perin	10	5	8.5			30 by 20	1.8	.50	.....	.....
46	Will Rowlon	8	3	8.8					.50	.....	.....
47	W. M. Robinson	8	4	8.5					.25	.....	.....
48	J. Worthing	8	4	8.5	20	28.5	6 by 8	5	1	1901	2.25
49	J. Zimmerman	6	3	10	15	25	45 by 50	3.1	.75	1900	1.50
50	S. P. Boyer	8	6	13	24	37	40 by 10	1.8	.50	.....	.....
51	Geo. Inge	8	4	11	23	34	Tank		.50	1900	4.00
52	Fred Pyle	8	4	12.5	20	32.5	Tank		.50	1899	3.00
53	G. D. Gould	10	8	11	18	29	50 by 50	2.5	4	1894	3.25
54	A. E. Hearst	8	6	10	18	28	40 by 40	2.4	1.75	1900	2.25
55	W. D. Evans	10	4	12	13	25	Tank		.25	1902	2.00
56	G. S. Boyd	8	4	10	18	28	Tank		.25	1901	1.25
57	J. Gorloch	8	4	10	25	35	15 by 15	3	.50	1895	2.00
58	G. S. Boyd	8	6	10	18	28	35 by 35	3	1.25	1903	.....
59	M. Griggs	12	8	10	20	30	100 by 100	2	7	1901	2.00
60	G. Miles	12	8	10.5	18	28.5	50 by 160	2	6	.....	1.75
61	Dr. Love	12	8	9	28	37	Tank			1895	.....
62	B. Simmonds	8	6	9	28	37	20 by 20	1.5	2	1895	3.00
63	E. W. Hamilton	8	4	8.5	28	36.5	Tank		1	1901	.....
64	C. L. Groff	8	4	11	14	25	30 by 20	2.4	.75	1899	1.00
65	W. B. Nolen	10	4	11	20	31	40 by 40	2	1	1903	.....
66	J. S. Covert	10	8	11	22	33	50 by 50	2.4	3	.....	.....
67	John Baker	12	10	9.2	20.8	30	30 by 30	1.5	5	.....	.....
68	John Baker	10	6	11	25	36	30 by 50	3	2	1901	.....
69	John Baker	8	6	10	12	22	50 by 50	2.8	6	1898	.....
70	John Baker	8	6	12	10	22	.....	.....	.....	.....	.....
71	John Baker	8	6	10	12	22	.....	.....	.....	.....	.....

## VALUE OF CROPS IRRIGATED.

*Alfalfa.*—The popular impression that alfalfa yields from 5 to 8 tons per acre is entirely erroneous, for the usual tonnage does not run above 4 tons. Three tons is a fair average. The hay brings from \$4 to \$6 per ton, making a return of \$12 to \$24 per acre. Deducting \$1.50 per ton for labor, the profit on 1 acre is \$7.50 to \$18.

*Beets.*—Sugar beets yield on the average in the Arkansas Valley about 13 tons per acre. The average tonnage of fields well cared for is much higher, running up to 18 and even 25 tons. The beets raised under windmills are all well tended and bring \$6 per ton to the grower (\$1 bounty from the State of Kansas), or from \$90 to \$120 per acre. Deducting \$35 per acre for all labor, a profit of \$55 to \$85 is left (cost of hauling not considered).

*Fruit.*—Apples, plums, and cherries do well in the vicinity of Garden City, while peaches, apricots, and pears are less in favor, although some very fine peaches were seen in 1904, and several young orchards have been recently put in. Cherries are a sure crop, and in 1904 yielded as high as 200 bushels to the acre, worth \$2 to \$3 per bushel.

*Sweet potatoes.*—This crop does exceptionally well around Garden City, the average yield being reported as 100 to 300 bushels per acre. The price varies from \$1.50 per bushel early in the season to as low as 50 cents. The average is given as \$1. The cost of the plants and the labor of setting them out is \$20 to \$30, making the return from 1 acre about \$150 to \$200.

One 4-acre piece in sweet potatoes was seen that was being worked on shares, the owner to furnish the land, water, seed, and half the cost of planting, and to receive half the crop and half of any surplus plants started in the hotbed. His investment was as follows:

Land, at \$60.....	\$240
Plant for irrigation.....	282
Seed .....	28
Half planting .....	21
Total .....	571

## Returns from one crop:

Half 50,000 plants, at \$2 per 1,000.....	\$50
Half 800 bushels, at 75 cents.....	300
Total .....	350

*Onions.*—The yield per acre of onions was given as 500 to 1,000 bushels, which sell at 2 to 3 cents per pound, returning the generous sum of \$500 to \$1,500 per acre. The cost of seeding and thinning is \$15 per acre. Others give the return as \$300 to \$500 per acre.



*Berries.*—A patch of raspberries measuring 0.25 acre yielded \$78, or at the rate of \$312 per acre.

*Cabbage.*—The value of an acre of cabbage is given as \$200.

*Other garden crops.*—The return from mixed garden crops is variously estimated at \$200 to \$500 per acre. A measured one-third acre in asparagus, onions, and pie plant produced in one season \$190, or at the rate of \$570 per acre.

The value of various crops raised by windmill irrigation may be summarized as follows:

*Value of crops per acre.*

Alfalfa .....	\$12-\$20
Alfalfa seed .....	17- 50
Sugar beets .....	90-120
Sweet potatoes .....	100-300
Onions .....	300-500
Cabbage .....	150-250
Garden crops generally.....	200-500

# PUMPING PLANTS IN COLORADO, NEBRASKA, AND KANSAS.

By O. V. P. STOUT,

*Professor of Civil Engineering, University of Nebraska, and Irrigation Engineer of the Experiment Station.*

## COLORADO.

### **WILLIAM KETTLEY, GREELEY.**

Mr. Kettley has a pumping plant 6 miles west of Greeley. The well is located in a draw immediately below a reservoir. It is 10 feet deep, rectangular, 12 by 16 feet, and is curbed with 2 by 8 inch plank, placed vertically. The water occurs in quicksands, and stands 4 feet from the top of the curb. One-half day's run of the pump at full speed empties the well. The well cost \$200, including the work of the owner.

The pump is a No. 2 vertical centrifugal, with 3-inch discharge pipe and no suction pipe. The pump is set on a timber frame in the bottom of the well. The lift is 11 feet and the discharge 60 gallons per minute. The pump is operated by a 5-horsepower vertical-cylinder gasoline engine, which is set on a timber frame. Gasoline costs 20 cents per gallon, or about \$1 per day when the pump is in use. The entire cost of the engine and pump f. o. b. Denver was \$586. The water from this plant is used on 70 acres, which also receives water from a reservoir. The plant was not used in 1904, as the engine was out of order, due to freezing. The engine was not housed, which probably accounts for its poor condition.

### **O. HOWARD AND F. W. STEELE, GREELEY.**

This plant is located 1 mile east of Greeley. The well is about 50 yards from the center of the slough. It is rectangular, about 10 by 12 feet; curbed with 2 by 8, 10 and 12 inch plank, placed vertically; about 12 feet deep. The water occurs in coarse gravel at a depth of 5 feet. Water is run into the wells through a cut from the slough and stands at the top of the well when the pump is not in operation. The pump empties the well in 30 to 60 minutes, and the trench connecting the well and the draw is to be enlarged and deepened in the hope of increasing the water supply. The well cost \$50 to \$60, including the work of the owner.

The pump is a No. 4 vertical centrifugal, with no suction pipe, and 5-inch discharge pipe 13 feet long. The pump is set on a timber

frame and is connected to the engine by belt. The lift is 5.5 to 13 feet. At a speed of 455 revolutions per minute the pump was discharging 675 gallons per minute. The pump cost \$80 and the pipe and connections \$25. The pump is operated by an 8-horsepower horizontal-cylinder gasoline engine. It is inclosed in a small frame house. The cost of the engine was \$460. Gasoline cost 21 cents per gallon.

This plant is to supply water to 60 acres; 40 acres were in crop in 1904—15 acres of sweet corn, 7 acres of watermelon and cantaloupe, 1 acre of squash and pumpkin, and the remainder in oats and millet. When visited in 1904, the plant had been in operation but two days, so that it had not been thoroughly tested. The total cost for well, pump, and engine was \$620, or \$10.20 per acre for the 60 acres to be watered. The owner estimates that the value of his land has been increased from \$1,000 to \$2,000 by the putting in of this plant and that the land will ultimately increase in value to \$5,000.

#### FRED DUEBACH, GREELEY.

Mr. Duebach's well is in the bed of a draw, and a small ditch carries seepage water into the well. The well is 6 by 4 feet, curbed with 2-inch plank placed horizontally. The well is but 4 feet deep, and the water occurs in fine gravel at a depth of 1.5 feet. The putting down of the well required no expenditure of money and but little labor. The pump is a No. 2½ horizontal centrifugal, with 6 feet of 3.5-inch suction pipe and 6 feet of 3-inch discharge pipe. The pump is set on a timber frame directly over the well. The average observed lift was 8 feet, and at a speed of 523 revolutions per minute the pump discharged 270 gallons per minute.

The engine is a 4.5-horsepower gasoline, with horizontal cylinder, set on a concrete foundation. Five gallons of gasoline will run the engine ten to twelve hours. The entire plant cost \$425 and supplies water for 7 acres in truck, making a cost of \$60.70 per acre. As the plant was installed in July, 1904, the financial success of its installation had not been tested at the time it was visited.

#### J. C. VAN AKEN, EVANS.

This plant is 0.5 mile from Evans. The well is about 150 yards below the lower Latham ditch and between the ditch and the river, in a slough. It is 10.5 feet in diameter, 9 feet deep, and is curbed with 2 by 4 inch timbers, placed vertically. The water occurs in coarse and fine gravel, mixed, about 4 feet from the surface. Two and one-half feet of 24-inch sewer pipe has been placed in the bottom of the well, and it is proposed to make the well 1 foot deeper and put down three 6-inch points to a depth of about 8 feet. The curb was

sunk by weighting with sacks of sand and digging out inside. The cost of the well was about \$60.

Water is lifted about 10 feet by a No. 4 horizontal centrifugal pump, with suction of 6-inch pipe 10 feet long and a discharge pipe 8 inches in diameter and 32 feet long. At a speed of 520 revolutions per minute the pump discharged 558 gallons per minute. The pump is set on a timber frame across the top of the well and is belted to the engine.

The pump is operated by a 10-horsepower gasoline engine set on a concrete base. At a speed of 255 revolutions per minute 8 gallons of gasoline will run the engine ten hours; at lower speeds the consumption of gasoline is less. Gasoline costs 21 cents. There is no expense for attendance, as the pump is left running for hours without any attention. The entire cost of machine and connections was \$750. The plant was installed in June, 1904, and is to supply water to 80 acres. The cost per acre is therefore \$9.38.

#### L. A. FLINT, EVANS.

This plant is located 2.5 miles due east of Evans on the table-land. The well is 8 feet in diameter and 16 feet deep, curbed with 2 by 4 inch timbers, placed vertically. Water occurs in gravel 3 feet from the surface and draws down to within 1 foot of the bottom of the well when being pumped. Perforated pipes 10 feet long have been put down in the bottom of the well, and it was found that this gradually increased the flow.

The pump is a No. 4 centrifugal, with a suction pipe 5 inches in diameter and 16 feet long and a discharge pipe 6 inches in diameter and 22 feet long. The average lift is about 16 feet.

The pump is operated by an 8-horsepower gasoline engine set on a timber frame. The entire cost of the machinery at the farm was \$600. Gasoline cost 20 cents per gallon and \$2.25 for a run of seventeen hours. This pump supplied water to 40 acres in 1901, but has not been used since, as the land is now supplied with water from the reservoir, making pumping unnecessary. The machinery is, however, kept in condition for use in emergencies. The cost of the plant was \$15 per acre for 40 acres supplied with water in 1901.

#### P. AND C. HUFFSMITH, EVANS.

This plant is located 3.5 miles east and 1 mile south of Evans. It is in a draw below the Latham reservoir, and a cut-off drain across this draw empties into the well. The well is 12 feet in diameter and 12 feet deep and is curbed with 2 by 4 inch timbers, placed vertically. Water occurs in quicksand and gravel 4 or 5 feet from the surface. The capacity of the well was about 500 gallons per minute, but at

the time it was visited 4-inch points were being put into the bottom of the well to reach 5 or 6 feet into the gravel. The curb was weighted with sand sacks weighing 20 to 25 tons and lowered by digging inside. The well was unfinished when it was visited and had cost up to that time between \$600 and \$700. The fineness and great depth of the quicksand made the sinking of this well an unusually difficult problem. A No. 6 horizontal centrifugal pump was used. The suction pipe had a diameter of 7 inches and a length of 14 feet. The discharge pipe was 35 feet long. The pump is set on a timber frame across the top of the well and is primed with water kept in a barrel above the pump. At a speed of 528 revolutions per minute the pump discharged approximately 1,000 gallons per minute.

The pump is operated by a 15-horsepower horizontal-cylinder gasoline engine, set on a concrete base. The entire cost of the pump and engine was about \$850. The plant was installed in 1904 and is to supply water to 200 acres; 95 acres were being watered in 1904. The land is sandy and gravelly and is badly affected with alkali, as it receives seepage water from the reservoir above. Taking the cost of the well at \$650, the entire cost has been \$1,500, or \$7.50 per acre for the 200 acres to be served.

#### **PERCY CLEGG, WINDSOR.**

This well was being put down in 1904 a mile north of the bank of the lake at Windsor and on ground about 5 or 6 feet above the lake. It was about 30 by 60 feet at the surface of the ground. Five feet below the surface it contracts to a curb about 8 by 30 feet. This curb is made of 3-inch timber driven vertically as sheet piling. The sheet piling is supported by a frame of 4 by 6 inch material. At the time the well was visited it had reached a depth of about 15 feet. The bottom was in quicksand, which extends for some distance farther. It was proposed to continue the piles into the gravel and excavate inside the curb down to the gravel. Up to that time \$800 had been expended, and the owner estimated that the well would cost \$1,000. A No. 5 horizontal centrifugal pump had been purchased, but not installed.

#### **N. E. GRAY, WINDSOR.**

This well is on a table-land 1.25 miles west of Windsor. It is 10 or 12 feet in diameter and about 16 feet deep. It is curbed with 2-inch planks driven vertically. The water occurs in gravel. A gallery or trench 7 feet wide and about 30 feet long runs out from the well. This is curbed in the same manner as the well itself and adds considerably to the water supply. The lift was 13.75 feet when observed. The pump is a No. 5 vertical centrifugal, with 5-inch discharge about 16 feet long, and is set on a wooden frame. The esti-

mated lift is 14 to 16 feet, and at a speed of 420 revolutions per minute the pump discharges 350 gallons per minute.

The pump is driven by a portable 16-horsepower horizontal-cylinder gasoline engine. The pump will run 10 hours on 7 or 8 gallons of gasoline, the gasoline costing 22.5 cents per gallon.

This plant supplies water to 80 acres, 40 acres being in beets and 40 acres in alfalfa. It was installed in 1901 and the land received no water except that supplied by the pump until 1904, when some ditch water was used. The operation of the plant cost \$110 in 1903, or \$1.38 per acre. This is cheaper than ditch water and the water is considered nearly as good, although it has not the fertilizing properties which the ditch water has, and it is also considered necessary to run the water some distance in a ditch in order to take off the chill before applying it to plants.

#### **DARNELL AND FULLER, WINDSOR.**

This well is on a table-land four blocks south of Main street in Windsor. It is 8 by 16 feet and 25 feet deep. Water occurs in sand and gravel at about 15 feet from the surface. It is curbed with 3-inch timber, the frames being made of 4 by 6 inch timbers. When being pumped at the rate of 441 gallons per minute, water stood 6 feet from the bottom of the well. The curb was built on a frame as the excavation was carried on, and was lowered by being weighted by boxes of sand and gravel. The well cost \$425.

Water was raised by a No. 4 vertical centrifugal pump and discharged through a 5-inch galvanized-iron pipe 27 feet long. The lift varied from 21 to 27 feet. With the engine running at a speed of 185 revolutions per minute the pump discharged 441 gallons. The cost of pump and connections was \$125.

The pump was driven by an 18-horsepower horizontal-cylinder gasoline engine set in concrete. The fuel consumption was 1.1 gallons of gasoline per hour, gasoline costing 20 cents per gallon. Oil cost about \$5 for the season. The engine cost \$950.

Fifty acres in potatoes, beets, and fruit were supplied with water, although this land received some ditch water. This plant was established in February, 1904, and was run every day during the irrigation season from 5 a. m. to 10 p. m. The owner is fully convinced that the establishment of this plant is a profitable investment, although the returns for the season were not complete at the time the plant was visited. Reservoir water can be secured for this land for \$80 per year. This guarantees a run of 30 inches for ten days. The cost of pumping this quantity for the same length of time is about one-half as much.

The entire cost of the well and plant was \$1,500, or \$30 per acre for the 50 acres irrigated.

**RAYMOND AND WILLIAMS, WINDSOR.**

This plant is on the mesa, 2 miles west of Windsor. The well is 8 by 18 feet and 20 feet deep. It is curbed with 3-inch plank driven vertically. Water occurs in coarse gravel.

The pump is a No. 4 horizontal centrifugal, with a suction of 15.5 feet. At a speed of 517 revolutions per minute the pump discharges 360 gallons per minute.

The pump is operated by a 12-horsepower horizontal-cylinder gasoline engine, which consumes 10 gallons of gasoline in ten hours.

This pump was installed in July, 1904, and is expected to supply water to 75 acres. About 10 acres were being watered in 1904.

**ANDREW WILSON, EATON.**

This plant is 3 miles east of Eaton and about 50 yards from the left bank of Lone Tree Creek. The bottom of the well is about 8 feet lower than the bed of the stream, and a lateral ditch runs near the well. The well is 12 by 12 feet square at the top and about 9 by 9 feet at the bottom and 16 feet deep. It was originally curbed with 2-inch timber driven vertically, but the upper part of this has been strengthened by a curb of 2-inch lumber placed inside of the original curb. Water is found in coarse gravel 9 feet from the surface. This water-bearing gravel is 15 feet thick to bed rock. The pump draws the water down to the bottom of the well, and it is planned to put feeders in the bottom which will extend to bed rock.

The pump is a No. 4 vertical centrifugal, placed at the bottom of the well. The water is lifted 17 feet through 4-inch pipe, 17 feet vertical and 8 feet horizontal. At a speed of 540 revolutions per minute the pump discharged 675 gallons per minute. The cost of the pump was \$100 and the cost of the pipe and connections \$100. The pump is driven by a 20-horsepower simple noncondensing high-speed automatic steam engine. It was bought secondhand and cost \$800 when new. Steam is supplied by a 35-horsepower horizontal return tubular boiler. The cost of the boiler was \$350 and setting \$75. Eaton coal, mined about 2.5 miles from the plant, is used. This coal cost \$2.50 per ton, and 1 ton is used in fourteen or fifteen hours. The plant requires constant attendance.

This plant supplies water to about 90 acres. It has been used since 1886 or 1887, and the owner considers it a profitable investment. The water supplied by the pump is used as a supplemental supply, but the owner considers the well water fully as good as the ditch water. The total cost of the plant, not including the well, is \$1,425, or \$15.80 per acre.

Mr. Wilson has another plant 3 miles east and 2 miles north of Eaton, on the west side of Lone Tree Creek and nearly 100 feet from

it. The well is octagonal, with a diameter of 14 feet, and is 28 feet deep, the bottom being 25 feet lower than the bed of the creek. It is curbed with 2 by 8 inch plank, laid flat, horizontally, crib fashion, with vertical 2 by 8 inch plank on the outside, 1 inch apart, thus leaving openings 1 by 2 inches all the way down. Water occurs in gravel at 3 feet from the surface. The well penetrates the gravel 25 feet, and bed rock is about 3 feet below the bottom of the well. The pump will draw the water down about 16 feet when running at full capacity. The cost of the well was \$800.

The pump is a No. 6 vertical centrifugal, with no suction pipe, and a 7-inch discharge pipe 26 feet vertical and 320 feet horizontal. The measured discharge of the pump was 1,575 gallons per minute. The cost of the pump was \$125, and the pipe, etc., \$400.

The pump is driven by a 40-horsepower side-crank steam engine. The steam is furnished by a 60-horsepower horizontal tubular boiler. The cost of the engine was \$400, boiler \$400, and setting \$100. Oil cost about \$10 per season.

This plant is to supply water for 400 acres; 320 acres was being irrigated in 1904. It was installed in 1892 and has been in use every season but two since that time. The fuel used is Eaton coal, which costs \$2.50 per ton at the mine, about 2.5 miles from the plant. The plant requires constant attendance. The total cost is \$2,225, or \$5.54 per acre for the 400 acres served. The owner considers this plant a profitable investment.

#### O. J. BLANDIN, EATON.

This plant is 3 miles east and 2 miles north of Eaton. The well is nearly 0.25 mile west of Lone Tree Creek, is 6 or 8 feet in diameter, 28.5 feet deep, and is curbed with 1 by 4 inch boards laid flat, horizontally, with 1 by 6 inch pieces used in the lower 10 feet. Water occurs in gravel at a depth of 12 feet. The total thickness of this gravel stratum is unknown. When observed the water stood 25 feet below the surface, while the pump was running. A piece of old smoke-stack was sunk in the bottom of the well to increase the supply.

A No. 5 vertical centrifugal pump is placed at the bottom of the well, the discharge pipe being 6 inches in diameter, and having a vertical length of 26 feet and horizontal 10 feet. At a speed of 550 revolutions per minute the pump discharged 470 gallons per minute. The cost of the pump was \$120.

The pump was driven by a 12-horsepower horizontal-cylinder gasoline engine, set on masonry foundation, and the engine uses about 1 gallon of gasoline per hour, at a cost of 22 cents per gallon. The engine cost \$650 and the shed about \$50. The engine is visited about once in one or two hours. This plant supplies water to 155 acres, 80 acres of which was watered in 1904. The plant was installed in



1902 and has been used every season, and the owner considers it a profitable investment. He can irrigate 10 acres of potatoes in one day of twelve hours, and claims that he can irrigate 1 acre once for 30 cents. The plant, exclusive of the well, cost \$820, or \$5.30 per acre for the 155 acres served.

**P. A. JONES, PIERCE.**

This plant is on a table-land above all of the irrigating ditches and the land therefore depends entirely upon pumped water. The well is 7 feet square, 38 feet deep, and is curbed with 1-inch lumber placed vertically down to the water and 2-inch lumber below the water, with 4 by 4 inch framing above the water, and 4 by 6 inch below the water. The framing is spaced 4.5 feet. The water is found in coarse gravel at a depth of 32.5 feet. The stratum is about 8 feet thick and rests on bed rock. The well cost \$55 for material and \$45 for labor in addition to that of the owner and his team.

A No. 3 centrifugal pump was placed at the bottom of the well; the discharge pipe is 3.5 inches in diameter and has a total length of 50 feet. The lift is 42 feet, and at a speed of 850 revolutions per minute the pump discharges 250 gallons per minute. The pump and connections cost \$103. A 12-horsepower horizontal thrashing engine is used. This was bought secondhand and cost new \$600. It requires constant attendance. The fuel used was Wyoming coal, which costs \$4.50 per ton, and the engine used 1,200 pounds in a run of fourteen hours. This plant was installed in 1904, and the owner is satisfied that it will prove a profitable investment. Water is used on 20 acres, but the owner estimates that it will supply a much larger area. The total cost was \$798, in addition to the labor of the owner and his team.

**S. L. SIMPSON, AULT.**

This plant is on the table-land, 2 miles east of Ault. The well is 10 feet in diameter and at the time it was visited was 12 feet deep, but was not finished. It is curbed with 2 by 4 inch timbers, placed vertically. Water is found in coarse gravel at a depth of 7.5 feet. This gravel stratum has a thickness of 4.5 feet and the bottom of the well is on a bed of clay which is more than 8 feet thick. A gallery or trench extends 400 feet north from the well, in which a 15-inch tile is to be laid. The well will cost about \$500 when completed.

A No. 4 vertical centrifugal pump is at present used. It is placed at the bottom of the well and the discharge pipe is 6 inches in diameter and has a length of 60 feet, 14 feet of which is vertical. The present lift is 18 feet, but the water will be discharged at a lower level, making the lift 13 feet. The rated discharge of the pump is 900 gallons per minute.

The pump is driven by a 14-horsepower gasoline engine, which uses 8 gallons of gasoline in a run of ten hours. Gasoline costs 21 cents per gallon and oil costs about 20 cents per day. The plant requires little attendance, as it can be left several hours at a time.

Mr. Simpson intends to irrigate 160 acres with the water from this plant. The plant was installed July 20, 1904. The cost of the entire plant was \$1,350, or \$8.45 per acre for the 160 acres. Ditch rights, supplying both early and late water for this area, would have cost \$4,500.

### NEBRASKA.

#### J. M. McALEESE, BENKELMAN.

This plant is situated on the second bottom of the Republican River, a short distance from a small creek, but apparently entirely independent of it. The well is 13 inches in diameter and 32 feet deep. It is curbed with No. 20 galvanized iron, with riveted joints reinforced with iron bands on the inside. The lower 6 feet of this curbing is perforated with 0.25-inch round holes, punched from the inside. Water is found in coarse gravel at a depth of 5 feet. This gravel stratum is penetrated 27 feet, but is reported to have a depth of 1,600 feet and to rest on soapstone.

A No. 2 centrifugal pump is used. The suction pipe is 3 inches in diameter and the discharge pipe 2 inches in diameter. The lift is 12 to 14 feet, and the discharge 105 to 120 gallons per minute. The pump cost \$75.

The pump is driven by a 1.5-horsepower engine, which cost \$75, the shed costing \$50. The fuel consumption is 1 gallon of gasoline in 6 hours, gasoline costing 21 cents. The plant requires little attendance. The pump discharges into a reservoir with an area of 0.45 acre, corresponding to a capacity of 24,000 gallons per inch of depth. Thirty-two inches of water can be drawn from this reservoir. The seepage at first was 14 inches in forty-eight hours, but has decreased to about 1 inch in forty-eight hours. The reservoir cost about \$200.

This plant supplies water to 20 acres of vegetables. The plant, exclusive of the well, cost \$500, or \$25 per acre for the area served. In 1902 Mr. McAleese sold \$962 worth of produce, besides losing 12 tons of cabbage and 200 bushels of potatoes by freezing.

#### WILLIAM A. SHARPBACK, ALMA.

This plant is on the second bottom of Republican River. The well is 8 feet in diameter, 30 feet deep, and is curbed with brick. The water occurs in coarse sand and gravel at a depth of 12 feet, the water-bearing stratum being 18 to 20 feet thick. The pump draws

the water down to the bottom of the well, and at that point the well supplies all the pump can deliver. The well cost \$200.

Water is discharged into a reservoir 60 by 200 feet and 3.5 feet deep. Water can be drawn off to within 6 inches of the bottom. Four inches of "gumbo" was placed at the bottom and puddled by horses. There is very little seepage.

A No. 3 centrifugal pump, with a 3-inch discharge pipe, 26 feet vertical and 20 feet horizontal, is used. The lift is 26 feet and the discharge was about 300 gallons per minute. The pump is driven by a 4-horsepower gasoline engine set on a brick-and-cement base. The entire cost of the machinery for the plant was \$175. Gasoline cost \$7 per barrel, or about 75 cents for a ten-hour run. The pump supplies water to 22.5 acres. It has been used little since it was installed in 1902 on account of the abundant rainfall. The cost of the well and plant was \$375, or \$16.67 per acre for the 22.5 acres served.

#### **T. H. SMITH, REDINGTON.**

This plant is about 0.5 mile from Pumpkinseed Creek and about 40 feet above the creek. The well is 10 feet in diameter and 29.5 feet deep. The water occurs in gravel, with quicksand near the top, at a depth of 24 feet. The well was unfinished when visited.

Mr. Smith has a No. 5 centrifugal pump, with 6-inch suction and 5-inch discharge, and a 15-horsepower horizontal-cylinder portable gasoline engine. The machinery for this well cost \$1,100. At the present depth the well will not supply sufficient water to operate the pump at its full capacity.

#### **BENNETT LIVE STOCK COMPANY, KIMBALL.**

This plant is 4 miles from Kimball, on the right bank of Lodge Pole Creek and about 180 feet from it. The well is 12 feet square and 13 feet deep and is curbed with plank driven vertically. A trench connects the well with Lodge Pole Creek and is supposed to intercept the underflow. Both the well and this trench go down to hardpan.

A No. 9 centrifugal pump with 9-inch discharge is used and lifts 4,000 gallons per minute.

The pump is driven by a 28-horsepower gasoline engine, which can also use crude oil. A half-and-half mixture of crude oil and gasoline is used, the consumption being about 2 gallons per hour. Gasoline costs 20 to 25 cents per gallon and the crude oil \$2 per barrel.

**KANSAS.****D. H. LOGAN, GARDEN CITY.**

This plant is on the flat about 1 mile from Arkansas River at Garden City. The well is 20 inches in diameter and 30 feet deep, with feeders reaching to clay at a depth of 56 feet. The well is curbed with galvanized iron perforated at the lower end with slits punched from the inside. Water occurs in gravel at a depth of 12 feet.

A No. 3 horizontal centrifugal pump is used. The suction lift is about 20 feet and the total lift a little more than 22 feet. The measured discharge was 270 gallons per minute. The pump is driven by a 6-horsepower vertical-cylinder gasoline engine set on a cement-and-timber base. Gasoline costs 22 cents per gallon, and 1 gallon will run the engine one and one-half hours. The entire cost of the well, pump, and engine was \$450.

This plant and windmill supplies water to 18 acres regularly, and in 1902 and 1903 to 2 acres extra. The cost of the plant was \$22.50 per acre irrigated. The owner states that this is without question a profitable investment.

**ABANDONED PLANTS IN NEBRASKA.**

In taking up the subject of lifting water for irrigation in Nebraska, a fact which comes early to the attention of the investigator is that a considerable proportion of the plants which have been installed and put in operation from time to time have been abandoned. The facts concerning these abandoned plants may be as instructive and a knowledge of them may be of as much value to those contemplating the use of other than gravity supplies as would a study of the newer plants which are still in service, many of which may be said to be still on trial or in the experimental stage. Consequently, some of the facts which have been learned relative to pumps and water elevators which have failed to justify themselves or to confirm the judgment of those who were responsible for their installation will be set forth.

In an analysis of the reasons for abandonment, an important distinction which should be borne in mind is that which obtains between those which do and those which do not weigh as arguments against the practice of lifting water for irrigation under the same or similar natural and commercial conditions.

A plant was installed in 1893 or 1894 at Ulysses, Nebr., to pump water from the Blue River. It consisted of an elevator of the bucket type, driven by a portable steam engine. The lift was about 30 feet. The area irrigated is stated to have been about 60 acres. Potatoes were raised for market, melons for seed, tomatoes for catsup, and other minor crops for market and home consumption. The plant was

put in by a man who was financially involved, in the hope that it would enable him to pay out. He operated it for two seasons, when his creditors closed him out, and the plant was abandoned. The statement is made on good authority that the plant in itself was a paying investment, and would have been proven to be such if its continued operation had been permitted.

Water was pumped from Blue River at Milford in 1895, 1896, and 1897. A No. 4 centrifugal pump was driven by a steam engine. Coal cost \$3.50 per ton, and 500 pounds per day was consumed. The lift was 11 feet. Eighty acres were irrigated, the principal crops being potatoes and corn, although a considerable area of melons was raised. The yields were not satisfactory, and as a reason for abandonment of the plant the broad statement is made that it did not pay. It is stated that a part of the disappointment of the owner arose from market conditions which caused the loss of perishable products, and that his larger interests monopolized his time during the latter part of the period to the exclusion of proper attention to the plant and the irrigation farming under it.

On the south side of the Platte River, in the vicinity of Cozad, a 6-horsepower gasoline engine and a pump were installed in 1898, at a cost of about \$500. The water supply came from a 6-inch point well, 32 feet deep, with water in half its depth. The reservoir was 30 feet square and 3 feet deep. Gasoline cost 20 cents per gallon. Figures stated as the time of filling a tank indicate that pumping was at the rate of 300 gallons per minute. The plant was operated for one season to irrigate about 1 acre of garden and orchard, and was then abandoned as too expensive. The pump is still in the well and the engine is used for grinding. From what could be learned it is believed that this plant did not receive anything like a fair trial.

In 1894 and during the early part of 1895 an 8-horsepower gasoline engine was used to drive a 4½-inch centrifugal pump in raising water from Buffalo Creek and from a well on its banks northeast of Lexington. The rated capacity was 1,000 gallons per minute. About 1.25 gallons of gasoline, at 13.25 cents per gallon, were used per hour. The well was sunk 6 feet into water-bearing gravel, but the supply obtained, together with the small amount which the creek would furnish at that time, was not equal to the capacity of the plant. Three acres of potatoes and some 25 or 30 acres of alfalfa were irrigated. In 1895 the Farmers and Merchants' canal was built to cover the land which included this tract, and in view of this fact and the inadequacy of the water supply the plant was abandoned. Incidentally, it may be noted that Buffalo Creek has now become a perennial stream of fair volume.

In 1894 a plant was installed on the south bank of the North Platte River, northwest of Paxton. The total lift was 52 feet, about

20 feet being suction. The discharge pipe was about 200 feet long and 12 inches in diameter. The well was 8 feet square and was only 20 feet from the river. Its depth was 20 feet, which placed its bottom 1 foot below the river bed. The yield of water was unequal to the capacity of the plant. The cylinders are 18 inches in diameter and 36 inches long. Steam was supplied by a 40-horsepower boiler, bricked in, and inclosed in a house with brick floor. It is stated that 18 strokes per minute was the most favorable speed for the pumps, as the cylinders did not fill satisfactorily when the speed was increased beyond that. Slack coal cost \$4 per ton at the railroad, and was hauled 8 miles. For continuous running, coal was used at the rate of 1.5 tons per twenty-four hours. It was the intention to irrigate 160 acres, and spring wheat was to be the principal crop. The sellers of the pump claimed it would irrigate 400 to 500 acres, but the irrigator thinks this claim was entirely too large. The cost of the entire plant was about \$1,000. The cost of operation for twenty-four hours, including fuel, attendance, and irrigation, was about \$12. The plant was operated for about thirty days. Before operation was resumed the owner lost the ranch and the new owners abandoned the pumping plant. The former owner considers that the operation would not have paid in any event.

During 1900 and 1901 a No. 4 or 5 centrifugal pump, driven by a 16-horsepower gasoline engine, lifted water to a height of 31 feet from a well which was connected with Driftwood Creek, near McCook, Nebr. With gasoline at 20 cents per gallon, the cost of a run "from sun to sun" was \$3. It cost \$75 to irrigate 40 acres. The plant cost \$860. It was abandoned when the rate for water from the McCook ditch was made satisfactory to the owner.

During the dry years about 1895 five link-belt elevators were sold in the vicinity of Stratton, to be driven by horsepower. It is stated that too much power was required to run them; rainfall increased to the extent of discouraging their use, and they were abandoned and fell to pieces. The writer visited one of these when it was in operation and noted that it was not speeded nearly high enough for effective performance. A similar elevator, also driven by horsepower, was tried near Cozad, but was abandoned on account of the large amount of power required to operate it.

At about the same time the other elevators were in operation one was placed in the Middle Loup River at Seneca. It was driven by water power, an undershot wheel being used. The design of the wheel and sluice was crude and the construction was even more so. However, after some changes in construction, water could be lifted, but not in the quantity that had been anticipated.

The foregoing record of failure and abandonment may seem to suggest strongly the general inadvisability of attempting to lift water

by mechanical means for irrigation in the semiarid and subhumid regions. None of the plants now known to be in operation, all of them comparatively recent installations, has gone far enough to demonstrate conclusively that the ground water can be lifted and made to pay in its application to the land. It is believed, however, that an examination of the facts which have been presented will show that they do not constitute a case against the pumping plant in Nebraska. Enumerating the primary causes of failure in the instances which have been cited, they are, in two cases, creditors foreclosed; in another, lack of market for the crop caused loss and larger interests of the owner caused him to neglect and finally abandon the plant; and in others, the inaptitude of the operator, introduction of gravity supplies, unfitness of motive power, and crude design and poor construction of homemade appliances were the cause of unfavorable showings. In none of these instances, it will be observed, do we note the inadequate performance of engines or pumps of established type and make, nor an inadequate water supply that might not have been augmented by the simple expedient of deepening the well.

## IRRIGATION NEAR ROCKYFORD, COLO., 1904.

By A. E. WRIGHT,

*Agent and Expert, Irrigation and Drainage Investigations.*

The three important crops raised in the Arkansas Valley in Colorado are alfalfa, sugar beets, and cantaloupes. Beets, more than any other crop, depend on constant care and cultivation for their tonnage and sugar content, and methods of irrigation have more influence on the value of the crop than is the case with any other crop.

### **SUGAR-BEET IRRIGATION.**

The first irrigation for beets is to bring up the seed. The ideal method is to wet the ground thoroughly during the winter or in the early spring before plowing. If irrigated after plowing the soil must be well harrowed before the seed is drilled in. Many of the best fields noticed were planted in this way in the last days of March and came up in two weeks, giving almost a 100 per cent stand of beets. Several of these fields received no further moisture aside from rain (5 inches in April, May, and June) until the last of June. At that time they were larger and more promising than most of the later plantings. No case of replanting on account of too early seeding was observed.

One advantage of winter irrigation for beets which would be much more important in average years than in 1904 is that water is in less demand than during the growing season, and a large saving of water is thus effected. But the main advantage is, probably, the greater ease with which a good stand of beets is obtained, for it avoids all the difficulties of "irrigating to bring up the beets," which is done as follows:

After the seed is drilled in, light furrows are run between rows or in alternate spaces with shovels set at the required distance on an ordinary wheel cultivator. (See p. 618.) Care must be taken not to throw too much earth on the seed, and hence the furrows must be made shallow. On the other hand, if too shallow, the water will run over the edges. It is essential to wet the soil without flooding, for the silt-laden water of the Arkansas forms a coating of mud which bakes in the sun as hard as a brick and through which the slender young plant can not force its way. In case all or part of a field has been unavoidably flooded, the crust must be broken up just as soon as it



is dry enough not to stick to a steel-toothed harrow. Such harrowing does not disturb the seed if done soon enough. (See p. 618.) But two or three fields were observed where the sprouting seedlings had already grown into the under side of the crust and were thus torn out by the roots when the crust was harrowed. (See p. 618.) It is generally the practice to cultivate after every rain which is heavy or pelting enough to crust the surface.

The general plan for the irrigation of beets is the same throughout the valley. The rows are usually 18 inches apart, though a small percentage of growers prefer to space them 20 inches. Deeper furrows can be made between 20-inch rows, and water is thus applied lower and deeper, which is an advantage probably offset by the greater loss of water from the greater unshaded area between rows. The objects to be attained are evenness of distribution, ease and cheapness of construction, and economy of time in irrigation.

The water is first run into the head lateral by means of the check and gate in the side lateral. Owing to the expense of building and resetting wooden boxes every year many still use a temporary earth dam for a check and make a cut in the bank for a gate. Canvas dams are in more favor than wooden boxes, being cheaper and not much more troublesome to use. If the fall in the head lateral is light enough (less than 0.6 or 0.8 foot in the length of the lateral), the entire number of rows may be irrigated at one "setting" of the dams, but usually 10 to 50 rows are watered at once, depending on the quantity of water available and the capacity of the lateral system. Enough must be turned down each furrow to reach the lower end in reasonable time, for on most land the upper end of the furrow will absorb much more water than the lower if this precaution is not taken. This effect is important in light irrigations, but can not usually be detected in cases where irrigation is heavy, for the absorption of water by the soil at the upper end is less after being wet to a certain degree. This is proven indirectly by repeated observations of the steady increase of waste water at the lower end of furrows during prolonged irrigation. When the water carries a large quantity of silt a smaller head will run through a long furrow. Deep furrows will absorb a larger head than shallow furrows, unless the slope is great. With a heavy slope and muddy water it is possible to run water through furrows in an astonishingly short time, the water soaking only 2 or 3 inches into the sides and bottom of the furrow. For this reason silt is considered by many a distinct advantage, especially where furrows are very long. (See p. 618.)

The furrows may be made in each space between rows or only in alternate spaces, in which case the spaces not furrowed out at one irrigation are chosen for the next, to avoid a one-sided growth of the beets. The length of the furrows varies from 300 feet or less up to

1,200. When furrows are very long and have little slope, especially in sandy soil, many growers log them out with the crude one or two horse devices shown in figures 75 and 76. This smooths and compacts the earth so that water is absorbed much more slowly. The practice of logging out is necessary in some cases, but it is an error to suppose

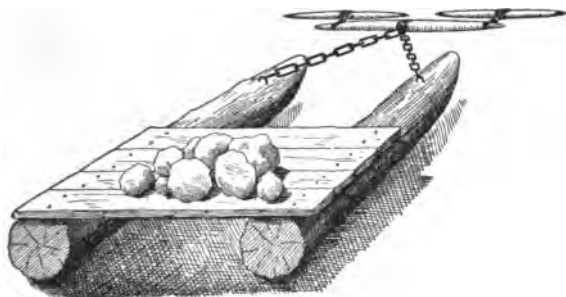

FIG. 75.—Device for logging out furrows, for two horses.

that it can at all increase the duty of water. It merely decreases the rate of absorption, and too often doubles the amount of waste water escaping at the lower end.

Where cross laterals are run through the fields all waste water from the upper set of furrows is collected in the cross lateral, from which it is readily redistributed down half a dozen or more rows below. Thus the irrigator can turn down into each furrow a much larger head than is needed without wasting water. It is, of course, impossible to gauge with any accuracy the tiny stream turned into one furrow, for the method is to make a series of cuts in the side of the head lateral and divide the water as evenly as the eye can judge, placing an upright stick in each cut and throwing against that a handful of

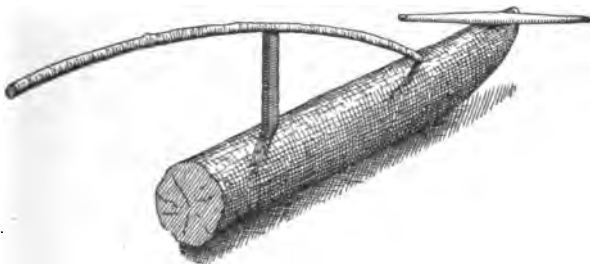

FIG. 76.—Device for logging out furrows, for one horse.

weeds or a piece of cloth or burlap. Where the mud is soft enough a weed is merely forced down into it with the shovel, where it will protect the bank from washing. One cut in the lateral supplies two furrows. This arrangement may save a little work in cutting the lateral, but it wastes a narrow strip of land parallel to each cross

lateral. A few irrigators favor the use of lath boxes set in the banks of laterals (fig. 77) especially for night irrigation (see p. 620), since they give an even flow to each furrow and are not apt to wash out in case the flow increases in the night.

When the first setting is sufficiently watered, a check is put in the head lateral farther down and the first dam taken out. This lowers the water in the head lateral enough to prevent its running out into the first set of rows, and so the cuts made in it for the first setting do not need to be refilled. A mistake often made by inexperienced irrigators is in making the first set at the lower end of a lateral. As a result each dam or check has to be built in running water, which is by no means easy to do. But by beginning at the head of the lateral each dam is put in dry, and in changing the set one merely has to make a rift in the dam above and let the water wash it out. When irrigating is finished, the lateral has but one dam, at the lower end.

When the upper set of furrows irrigated from the head lateral are all watered, the gate into the head lateral is closed and all the water is

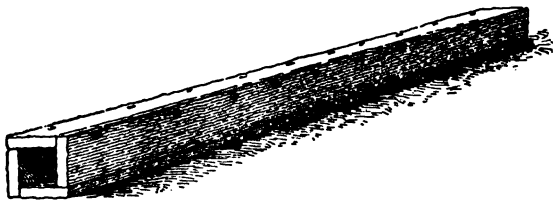

FIG. 77.—Lath box for distributing water from laterals.

run down the side lateral to the first cross lateral, where the distribution proceeds as before.

It very frequently happens that the waste water is not applied to the same crop. On one ranch the waste water from 15 acres of beets irrigated 5 acres of cantaloupes and the waste from the melons watered 2 or 3 acres of orchard and garden, the final remnant finding its way into the road, where it impeded traffic for a quarter of a mile.

Cultivation as soon as possible after irrigation is an absolute essential to successful beet culture. First, because it mulches the surface and conserves the moisture in the soil, but, what is vastly more important to the young beet, it breaks up the crust and gives the plant air, warmth, and room to grow. It is not enough merely to break up the top crust, except in a very sandy and open soil. In most soils irrigation tends to pack the soil for several inches, and to break up this compact mass it is necessary to use the "calf tongues" and to run them as deep as possible. Many use the "duck feet" at the same time, but this keeps the narrow tongues too near the surface. If a narrow and deep cultivation can be made in the cen-

ter between rows, the expansion of the beets themselves will be strong enough to loosen the soil around them. Failure to cultivate deep results in a "pinching" of the beet, which reduces its diameter and makes it grow in odd shapes.

#### **WATER APPLIED AT ONE IRRIGATION.**

During April, May, and the first half of June, 1904, 5 inches of rain fell, and irrigation was unusually light as a result. Half the water that filled all canals from a high river early in June was wasted at their lower ends or over wasteways. Measurements of single irrigations show greater variation than would be found in average years. Many cases were found where the ground was moist 3 inches below the surface, and the water applied served no useful purpose whatever. The data were obtained by measuring the head applied to a measured field or to a certain number of rows and finding out how long the water was run. In most cases there is no great accuracy in the estimate of time, which varied from a few hours to ten days. In several cases there were also considerable changes in the head during the time of irrigation, and an error is thus introduced.

Twenty fields were observed and the following statements regarding the depth of water applied at a single irrigation were obtained: Less than 0.2 foot was applied to 3 fields; 0.2 to 0.4 foot, to 5 fields; 0.4 to 0.6 foot, to 7 fields; 0.6 to 0.8 foot, to 2 fields, and 0.8 to 1 foot, to 3 fields. The average on the twenty fields was 0.48 foot in depth. (See p. 622.) The only way of estimating the total depth applied in a season is to assume that the same amount is used at each application. It is probable that the first irrigation was heavier than the one observed, which was in most cases the second, and that the third would be lighter. To arrive at the average duty of water for a dry year there should probably be added to the depth applied in 1904 the rainfall for 1904.

Many irrigators said that the number of irrigations would depend on weather conditions, so the estimates are probably too small for a fair average. The number varied from 1 to 4. Seventeen fields were observed, the depths received during the season, estimated as outlined above, being as follows: 0.6 to 1 foot was applied to 7 fields; 1 to 1.5 feet, to 4 fields; 1.5 to 2 feet, to 4 fields; 2 to 3 feet, to 2 fields. The average for the seventeen fields was 1.3 feet, all exclusive of rain. In several cases winter irrigation was practiced, which is not included.

#### **TIME AND LABOR REQUIRED.**

The average time for irrigating 1 acre of beets for the 20 fields was 3.5 hours, or nearly 7 acres in 24 hours. (See p. 619.) But it must not be supposed that the services of a man are required all the

time during an irrigation, for at night it is customary to set the water on as many rows as possible and let it run unattended for eight hours or more, the waste of, say, one-third of the water being less than the cost of extra care. It is then reasonable to say that one man can irrigate 5 to 15 acres of beets in a day, working ten hours, and changing the water late at night and early in the morning, and that the cost of applying water to beets is 10 to 30 cents per acre for each application, with wages at \$1.50 per day. (See p. 620.) Frequently boys are employed for this work, through failure to realize the importance and the small cost of having it done by an experienced man. A single row of beets may yield half a ton, and a slight neglect in seeing that a single furrow is well watered may cause a loss of several hundred pounds.

#### SUMMARY.

- (1) Winter irrigation and early seeding favor a good stand.
- (2) Harrowing or cultivation after rain or irrigation is essential.
- (3) The cross-lateral system is the most successful layout.
- (4) Silt is not considered a benefit to land, and though it aids hasty irrigation does not raise the duty of water (see p. 618).
- (5) An average irrigation is 6 inches (see p. 622).
- (6) The total depth of water required is not more than 2 feet, including rainfall.
- (7) The cost of applying water is so small as to make neglect and excessive waste inexcusable.

#### CANTALOUPE IRRIGATION.

In many ways the irrigation of cantaloupes is more difficult than the irrigation of beets. Flooding the young plants with muddy water or with water only fairly clear is fatal. If prolonged the plants are drowned, and if for a short time the crust that forms in the hot sunshine chokes the tender plants. The layout is generally the same as for beets, except that the furrows are run down one side only of each row, the rows being 5 or 6 feet apart. The furrows are made with a single shovel and are much deeper than it is possible to make them for beets. In the case of beets the water has to move laterally from the furrows only a few inches in order to soak the beets thoroughly, while with cantaloupes the water must move or "sub" a distance of 18 to 24 inches in order to wet the plants. For this reason it is usual to run the water much longer on them than on beets, and the waste is correspondingly great. The average waste in seven fields observed is estimated at 44 per cent. The average depth applied, not including waste, was 0.33 foot. The average area irrigated by one man in twenty-four hours was 3.5 acres. (See p. 620.)

The number of times water is applied to cantaloupes in one season varies from three to six, according to the amount used at one time, the total depth applied in 1904 being probably 0.5 to 1.3 feet. In a dry year this might reach 2 feet.

### **ALFALFA IRRIGATION.**

Alfalfa is flooded in two ways, either from the head of long lands or from cross laterals run nearly on contours. In the first method the lands run usually the full length of the field, being often as long as 1,600 feet. It is usually necessary to throw up a few low dikes in places to raise the water enough to cover the high places, and it is in handling these dikes that the skill of the irrigator comes into play.

In five cases observed the average depth applied was 0.4 foot; the area irrigated by one man in twenty-four hours, 12 acres, and the head handled by one man was 3 cubic feet per second.

The total depth in a season can not be determined by the above data, as it is customary to turn water on alfalfa whenever there is a surplus, and the quantity thus applied has never been measured. It is commonly said that one good irrigation is required for each of the three crops cut.

There were in 1903 (report of Water Commissioner Cressey) under ditches between Pueblo and Lajunta 113,000 acres, of which 64,000 acres were in alfalfa.

### **GRAIN IRRIGATION.**

Although the Arkansas Valley is not well adapted for grain raising, considerable grain is raised, especially as a shade crop for young alfalfa. (See p. 619.) Six fields were observed, the average depth applied measuring nearly 0.8 foot, or about 2 feet in the season. The variation was so great, however, that no conclusion can be drawn as to what quantity of water would satisfy the requirements of grain. One irrigator flooded his field with less than 0.2 foot in depth, while another ran on enough to cover his grain 1.7 feet deep. The rainy conditions account in part for these wide variations.

### **LATERAL DITCH COMPANIES.**

(Data given by W. M. Wiley.)

Under the Amity canal are organized 9 lateral-ditch companies, each incorporated under the laws of Colorado and managed by the irrigators under each lateral. The lay out of laterals under the Amity favors this arrangement, as the average acreage under each of the nine is over 2,000 acres. These laterals are built so as to run water

down each ridge crossed by the Amity, the sublaterals watering all the land on either side of the ridge as far as the center of each draw between ridges.

The general idea was taken from similar companies near Greeley, which were merely agreements of users to combine their laterals in one for the common interest. They built their own laterals and managed them through their organizations. The laterals under the Amity, however, were all built by the Amity company and turned over to the lateral-ditch companies by the canal company. A lateral company is organized as soon as there are three users under one lateral. Although they then "acquire, receive, own, hold, and possess" the lateral, title to the lateral is never actually passed by the company. Their right arises by use. They can not sell or dispose of the lateral. The company is then responsible for maintenance of the lateral and structures thereon and for the distribution of water therefrom.

Although the stock issued has a face value, it is issued to water-right holders without any cash payment. Shares are attached to certain described lands and are inseparable therefrom. The Amity canal becomes the shareholder for unsold water rights.

The programme of organization is as follows:

- (a) The incorporation is announced.
- (b) By-laws are passed at a general meeting.
- (c) Officers are elected.
- (d) An assessment is voted.

The advantages of the system from the standpoint of the Amity canal management are:

- (a) A saving of water by making rotation among laterals easier.
- (b) A saving in the expense of distribution.
- (c) The education of the farmers in water laws and customs and in making them responsible for the details of distribution.

Assessments run from 5 to 25 cents annually per acre.

Each user builds his own sublateral from a point ordered by the board.

One water right under the Amity is 60 acre-feet during the irrigating season and 20 during the nonirrigating season for 40 acres of land. The company is not responsible for nondelivery of the water, nor is payment required for water delivered in excess of the amount designated.

### **SMALL PUMPING PLANTS.**

#### **PLANT OF GOODNER BROTHERS, ROCKYFORD, COLO.**

Engine: 3-horsepower gasoline, 360 revolutions per minute.

Pump: 6-inch chain and float, with a bored 6-inch cylinder 40 inches long, the floats being fitted with expanding cast-iron rings and spaced 36 inches apart on the chain.

Discharge: 0.92 cubic foot per second, computed from speed of pump; 0.96 cubic foot per second, measured with current meter.

Lift: 13 feet.

Fuel used: 1 gallon gasoline in three hours and five minutes.

Useful work: 1.36 horsepower.

Gasoline horsepower: 3.25 (1 gallon equals 10 horsepower-hours).

Efficiency: 42 per cent.

Acre-feet per gallon of gasoline: 0.23.

Cost per acre-foot: \$0.87 (gasoline at \$0.20 per gallon).

Cost per acre-foot for each foot lift: \$0.067.

This pump would give much better efficiency if run slower. In the case observed the floats had a velocity of 5 feet per second and in entering the water carried down considerable air and caused an impact which must have absorbed a good deal of power. It should be made of larger bore for this capacity. The pull on the chain required to just start the pump with a 10-foot lift was 32 pounds in excess of the weight of the water column, which indicates an efficiency of 79.5 per cent when run very slow, no account being taken of leakage, which was too small to be detected. Measured with spring balance.

#### PLANT NEAR BRIDGE NORTH OF LAMAR, COLO.

Engine: 4 horsepower gasoline.

Pump: No. 5 centrifugal.

Discharge: 0.95 cubic foot per second by current meter.

Lift: 10 feet.

Fuel used: 1 gallon gasoline in two hours and thirty minutes.

Useful work: 1.08 horsepower.

Gasoline horsepower: 4.

Efficiency: 27 per cent.

Acre-feet per gallon of gasoline: 0.196.

Cost per acre-foot: \$1.02.

Cost per acre-foot for each foot lift: \$0.102.

Cost of plant: Engine, \$250; pump, \$100.

This plant irrigates about 20 acres of cantaloupes, fruit, and garden. Three to five acres are watered in ten hours, which indicates the application of from 0.16 to 0.26 foot in depth at each irrigation. About 1.8 feet in depth is applied in a season, which costs \$35 for 20 acres, or about \$1.80 per acre.

The owner sold his water right in a ditch because of difficulty in getting water when he wanted it. This was apparently due to very poor construction of a dike leading to this lowland lying near the river. He is confident that it costs him less to pump than to use ditch water.



**STATEMENTS REGARDING MR. WRIGHT'S REPORT BY W. K. WINTERHALTER AND OTHERS.**

Owing to the short time which Mr. Wright could give to the investigation at Rockyford, the preceding report was submitted to a number of parties living in that section and familiar with irrigation practice there for discussion.

Mr. W. K. Winterhalter, manager of the Lamar factory of the American Beet Sugar Company, was one of those to whom the report was sent. Mr. Winterhalter's discussion of the report and the replies received from his correspondents follow:

\* \* \* Yours of January 27 with the irrigation report of Mr. Wright was duly received, but owing to the pressure of work I have been unable to forward you my suggestions regarding changes in this report until to-day.

After reading Mr. Wright's paper on his observations in irrigation in the Arkansas Valley it occurred to me that several passages therein needed modification or alteration, and in order to satisfy myself as well as your Department as to the accuracy of these changes, I submitted to the most experienced irrigators of my acquaintance in the Arkansas Valley, all of whom are practical farmers and experts in the handling of water, several questions pertaining to the points which, in my opinion, were not quite clearly expressed in Mr. Wright's report. I attach hereto their replies and wish to say that same in most instances coincide completely with my views and I will leave it with you to make such changes in Mr. Wright's report as you may deem advisable and justified after perusing the opinions of the gentlemen whose names appear on the inclosed list.

You will notice that in some instances the opinions of these parties on the number of acres that can be irrigated in a day differ quite widely, but as a whole I think that some valuable information is contained in these individual reports and that the judgment of these representative farmers whose homes are scattered over a distance of 125 miles in length along the Arkansas River deserve close study and consideration. Now, as to Mr. Wright's report, permit me to comment as follows:

Referring to the passage where he speaks of beet seed being drilled and rows thereafter being run with cultivator shovels, I wish to say that this practice is almost entirely abandoned and that the best drills are now equipped with such shovels, making furrows between the seed rows at the same time that the seed is planted. Harrowing to break the crust before the seed is well germinated should always be done crosswise and not in the same direction in which the seed is planted, as there is danger of pulling out a number of plants if a harrow tooth follows a seed row for even a short distance. When the seed is well germinated and a crust forms on account of rain or careless irrigation, the spider attached to the cultivator is the only tool that will break the crust without doing considerable damage to the crop.

While Mr. Wright's statement that quick time can be made in irrigating with muddy water is correct, I wish to state that if we had clear water in the Arkansas River we could get along probably with one to two irrigations less and would avoid great difficulties and damage to crops of all kinds by the sediment that deposits on the surface and practically closes the pores of the soil air-tight until it commences to crack.

As to the average depth of water necessary for one irrigation, I believe that this point is quite well answered by the farmers in question No. 8, though it is very evident that even some of the best men have no conception of the quantity of water they are using for irrigating such crops as sugar beets and cantaloupes, much less for the irrigation of alfalfa and grain where promiscuous flooding is generally practiced.

Under "Grain irrigation" Mr. Wright mentions same as being generally used as a shade crop for young alfalfa. I wish he were right, because in my opinion there is no better way to get a good stand of alfalfa than by sowing it with spring grain or about the fore part of May into a crop of winter wheat, the latter being especially practical on account of the winter wheat having achieved considerable growth by that time, and thus prevents the rapid baking of the newly irrigated land. Unfortunately, however, only few farmers use a cover crop for alfalfa and mostly sow the same on the barren ground and take their chances on getting a stand. \* \* \*

**Question 1.** What do you consider average time necessary to irrigate 1 acre of beets if fall in lateral is about 0.6 to 0.8 inch per foot to length of lateral?

Enos Bowman: Three hours.

A. P. Koons: Four hours if water is clear or partly so.

P. K. Blinn: Two or three hours, or 4 to 5 acres per day of twelve to fifteen hours.

B. B. Koons: About five hours, depending on the amount of water.

N. W. Lamon: From three to four hours.

D. L. Joehuck: With full setting of water, five to six hours on length of 20 to 30 rods.

F. M. Harsin: Three hours.

Emery Robb: Four to six hours.

E. E. Cadwallader: Depends on lay of land and fall of furrow; also condition of water. Clear water requires one-third to two-thirds longer time than muddy water.

Thomas Loynd: Two hours per acre sufficient with fair head of water; kind of soil and time water is applied to govern to some extent time required.

Joseph Loynd: Two and one-half hours per acre with fair stream of water.

**Question 2.** How many acres of beets can you irrigate in twenty-four hours?

Enos Bowman: Three acres; my land irrigates slow.

A. P. Koons: From 5 to 15 acres, depending on grade of head ditch.

P. K. Blinn: Five and 6 acres with 40 inches, but not soaked long.

B. B. Koons: About 10 acres with 150 to 200 inches of water.

N. W. Lamon: From 6 to 7 acres.

D. L. Joehuck: About 6 to 7 acres with plenty of water.

F. M. Harsin: From 8 to 10 acres.

Emery Robb: Ten to 12 acres.

E. E. Cadwallader: Average of 5 acres with 60-inch head of water.

Thomas Loynd: Under usual conditions with fair head of water 10 to 12 acres each every twenty-four hours; size of stream and conditions of soil to be considered.

Joseph Loynd: Ten acres with fair stream of water and good land.

**Question 3. Do you think night irrigation of beets advisable? Have you ever let water run during night in your beet field? If so, how many hours?**

Enos Bowman: Advisable when no ponds to fill. Have irrigated some at night and let water run all night.

A. P. Koons: Have had good results night run, but prefer to run day time, as can keep rows up better.

P. K. Blinn: Yes, if well ditched and an experienced man sets the water; well-drained field as to waste water. If ran at night, would stay as late as could see, and 3.45 or 4 o'clock in the morning.

B. B. Kouns: Do not like to run water at night, except in times of shortage; however, have run at night.

N. W. Lamon: Yes, providing field will irrigate without flooding, because water applied during cool hours will have time to settle before the heat of the day and not scald plants.

D. L. Joehuck: Yes, during heat of summer; on land where water has slow course about five hours; distance, 20 rods.

F. M. Harsin: I do, if you stay with it. Most economical way to irrigate is to make lath boxes, one in each row, and if laterals are smooth and regular can irrigate day or night without flooding. Consider night irrigation best for any crop, as soil takes water better and evaporation not so great.

Emery Robb: Yes, on land that will not flood; eight to ten hours.

E. E. Cadwallader: Yes, during early part of season; I let water run all night, but not over six hours at a time the latter part of season.

Thomas Loynd: Yes; especially after first irrigation and during hot months. Have irrigated at night, but never in one place without changing as often or more often than in day time. Have known parties to irrigate all night without material damage. Some soils, however, would wash or bake.

Joseph Loynd: Night irrigation advisable, especially in hot weather or when water is scarce. Have irrigated all kinds of crops at night, but stayed with it.

**Question 4. How many acres do you think a good irrigator can irrigate in twelve hours with full head of water?**

Enos Bowman: From 2 to 5 acres.

A. P. Koons: Average about 10 acres.

P. K. Blinn: Say with 40 inches, from 4 to 6 acres.

B. B. Kouns: If land lays good and not too dry, would say about 5 acres.

N. W. Lamon: From 3 to 4 acres.

D. L. Joehuck: Three to 4 acres on sandy loam soil with medium fall.

F. M. Harsin: Not more than 5 acres and do it well.

Emery Robb: Six to 8 acres.

E. E. Cadwallader: On an average of 2.5 acres with 60-inch head of water.

Thomas Loynd: Average of 6 acres per day, conditions favorable; 6 acres first irrigation and 2 acres better afterwards on same field.

Joseph Loynd: Good irrigator can irrigate 5 acres in good shape.

**Question 5. What do you consider the lowest, highest, and average cost of irrigating 1 acre, figuring 15 cents per hour?**

Enos Bowman: Lowest, 30 cents; highest, \$1.50; average, 90 cents.

A. P. Koons: Lowest, 10 cents while beets are small; highest, 25 cents where ground is cracked and beets larger; average, 18 cents.

**P. K. Blinn:** Lowest, 25 cents; highest, 75 cents; average, 35 cents. This is mere guesswork.

**B. B. Kouns:** Lowest, 15 cents; highest, 60 cents; average, 30 cents

**N. W. Lamon:** Lowest, 35 cents; highest, 55 cents; average, 45 cents.

**D. L. Joehuck:** Lowest, 20 cents; highest, 60 cents; average, 40 cents.

**F. M. Harsin:** From 25 to 30 cents; all things considered, ought to be 30 to 40 cents per acre.

**Emery Robb:** Lowest, 15 cents; highest, 30 cents; average, 22.5 cents.

**E. E. Cadwallader:** Average, 50 cents.

**Thomas Loynd:** Usual cost for irrigating 1 acre varies from 20 to 50 cents per acre; cost governed by condition of field irrigated. Average, 35 cents.

**Joseph Loynd:** Lowest, 37.5 cents, even surface and good slope; highest, 75 cents, uneven and rough ground; average, 56.25 cents, farm ground in general.

**Question 6.** Do you think one can perform other duties while irrigating beet crop?

**Enos Bowman:** Do not think they can.

**A. P. Koons:** No, sir; I want every row through at the same time, and this requires constant watching.

**P. K. Blinn:** Not very well with good head; might hoe weeds in beets.

**B. B. Kouns:** If man can take care of the water and not waste the land, he has his hands full.

**N. W. Lamon:** Not advisable; too much danger of flooding.

**D. L. Joehuck.** Do not think it wise, though some do, and with good results; depends on soil.

**F. M. Harsin:** No; don't think they can, water cuts too many breaks.

**Emery Robb:** No; with full head of water.

**E. E. Cadwallader:** Can not with 60-inch head of water, but can with 40-inch head.

**Thomas Loynd:** Not as a rule, unless after first irrigation; if field is easy to irrigate, might pull weeds while irrigating.

**Joseph Loynd:** Can do other work if he has good piece of land and small stream.

**Question 7.** Which crop is more difficult to irrigate and needs closer attention, cantaloupes or sugar beets?

**Enos Bowman:** Sugar beets.

**A. P. Koons:** Sugar beets.

**P. K. Blinn:** Beets, because rows are smaller and more liable to flood.

**B. B. Kouns:** Sugar beets, but both will stand close attention.

**N. W. Lamon:** Sugar beets.

**D. L. Joehuck:** Sugar beets.

**F. M. Harsin:** Sugar beets.

**Emery Robb:** Sugar beets.

**E. E. Cadwallader:** Sugar beets.

**Thomas Loynd:** Sugar beets.

**Joseph Loynd:** Sugar beets, above all other crops.

**Question 8.** How many inches (in depth) of water do you consider necessary for one irrigation of beets? How many acre-feet for the season in order to raise and mature the crop, rainfall not taken into consideration?

Enos Bowman: Can not answer.

A. P. Koons: Can't say in inches; aim to run water pretty full head until it goes through rows, then cut off until all goes into ground, wet up to plants, then change.

P. K. Blinn: Probably 6 to 8 inches per acre-foot; four to five irrigations.

B. B. Kouns: Fifteen to twenty inches deep; from four to six thorough irrigations.

N. W. Lamon: From 2 to 2.25 inches; from 8 to 9 inches per season.

D. L. Joehuck: One and three-fourths inches for one irrigation, and about two-thirds acre-foot for the season.

F. M. Harsin: For one irrigation 176 inches, allowing 1 inch to row; for three irrigations 6 inches, or 1,056 for season.

Emery Robb: I do not know.

E. E. Cadwallader: Can not answer.

Thomas Loynd: Three to four inches for each irrigation; 9 to 12 inches should be sufficient to mature a crop if properly applied, with intensive cultivation as a preservative, nature of soil and submoisture to be considered.

Joseph Loynd: Three inches for one irrigation, and 1 acre-foot if cultivated properly.

**Question 9. How many acres of cantaloupes can one irrigator water in twelve hours?**

Enos Bowman: From 2 to 10.

A. P. Koons: Twenty-five acres.

P. K. Blinn: Six to eight acres.

B. B. Kouns: From 5 to 20 acres, according to the land and amount of water.

N. W. Lamon: From 12 to 18.

D. L. Joehuck: About 16 acres on sandy loam with sufficient water.

F. M. Harsin: From 5 to 7 acres on good land with even fall.

Emery Robb: From 8 to 12 acres.

E. E. Cadwallader: Ten acres under favorable conditions.

Thomas Loynd: Good irrigator can water 8 to 10 acres cantaloupes in twelve hours.

Joseph Loynd: Good irrigator can irrigate 15 acres in twelve hours if ground is in good shape.

**Question 10. How many inches (in depth) of water are necessary for one irrigation of cantaloupes; and how many acre-feet for season?**

Enos Bowman: Can not answer.

A. P. Koons: If can get my plants to vining stage without water, think it better, then irrigate four times in three weeks and a couple of times after they begin to ripen; no water between rows; takes twice as much water for beets.

P. K. Blinn: From six to eight irrigations; probably less water than beets.

B. B. Kouns: From 8 to 10 inches every ten days the entire season.

N. W. Lamon: From 0.75 to 1 inch, and about 5 inches per season.

D. L. Joehuck: Having only 2 feet of each furrow to irrigate every 6 feet apart, about 0.75 acre-inch for each irrigation, or 0.25 acre-foot for season.

F. M. Harsin: About 2 inches in depth and 6 inches for season. This means in dry weather.

Emery Robb: Do not know.

E. E. Cadwallader: Can not answer.

Thomas Loynd: Think cantaloupes can be irrigated with one-third less water than beets and crop matured with from 6 to 8 inches of water per season under normal conditions.

**Joseph Loynd:** One inch for one irrigation and 5 inches for season, if cared for properly.

The report was also sent to Thomas Berry, chief engineer of the Arkansas Valley Sugar Beet and Irrigated Land Company. Mr. Berry approved the report as a whole, but in regard to Mr. Wright's statement that the silt in the river water was regarded as a distinct advantage had this to say:

The experience under the Amity canal is that with muddy water the ground is covered very rapidly, but the irrigation is not so good as with clear water. With the latter, time and the quantity of water being the same, better crop results are attained than with silty water. On the steeper slopes clear water is decidedly preferable to silty water, but on the flatter slopes the results are more nearly similar.

The report was also sent to Mr. William Aukland, Olney, Colo. Regarding the use of muddy water, Mr. Aukland says:

My experience has been that the more silt the better the crop of beets or anything else. I always used all the muddy water I could last season. In some parts of the beet fields on my farm the silt was 2.5 inches thick.

Mr. Aukland emphasizes the value of irrigation for seeding, stating that it has a tendency to make the beets when starting follow the moisture down, thus securing much longer and better-shaped beets.

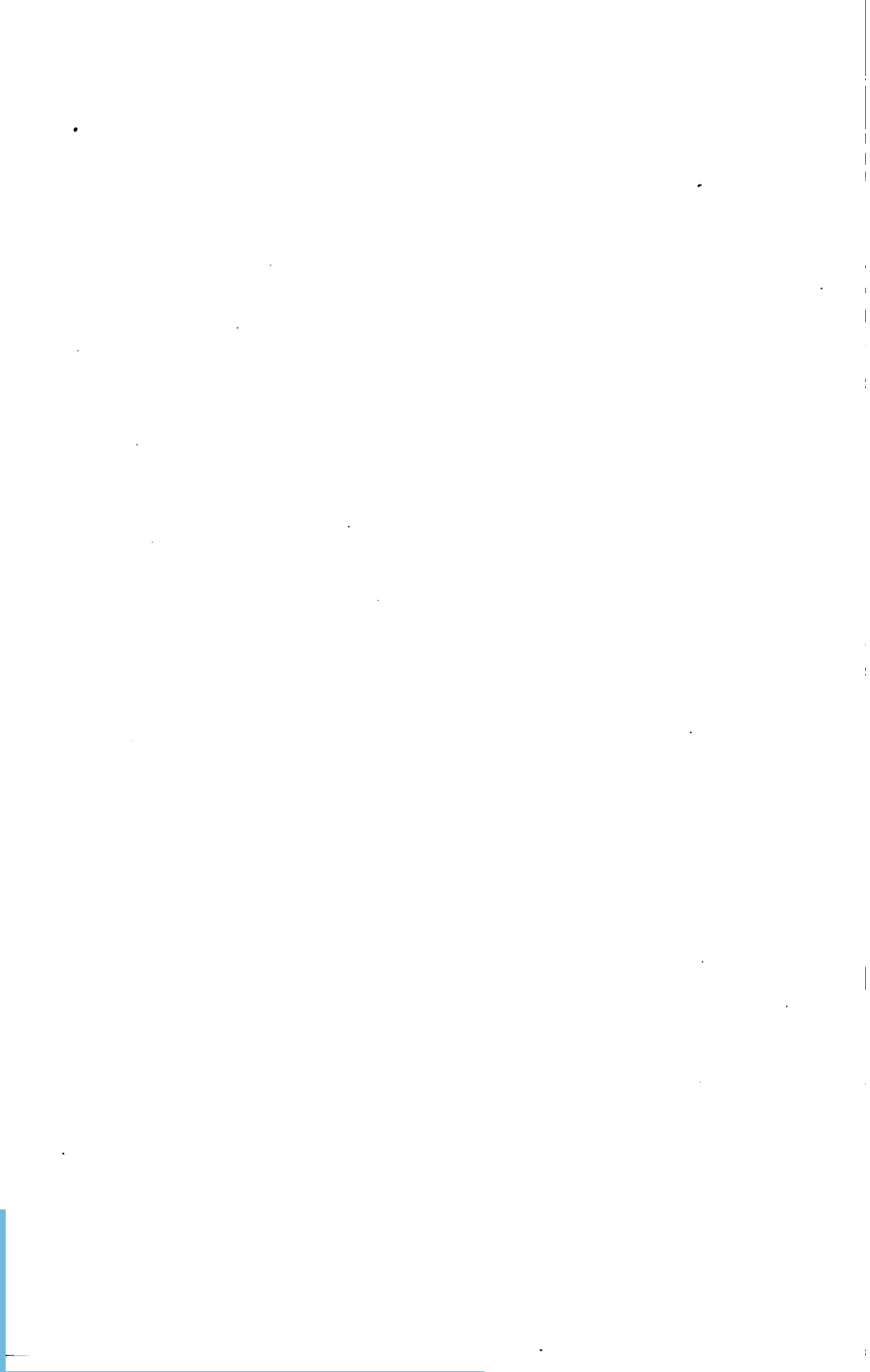

# THE IRRIGATION AND DRAINAGE OF CRANBERRY MARSHES IN WISCONSIN.

By A. R. WHITSON,

*Professor of Agricultural Physics, University of Wisconsin, and Physicist  
Wisconsin Agricultural Experiment Station.*

## INTRODUCTORY.

The cranberry is a native of Wisconsin, and is found growing in abundance on many of the marshes of the State. Indeed, up to ten years ago practically all of this fruit harvested in the State was gathered from these wild marshes. The great forest and marsh fires of 1894 and 1895, however, burned off large parts of these cranberry marshes and very greatly reduced the yield. Up to that time very little was done to control the conditions for cranberry culture. Since then it has become evident that successful cranberry raising requires a full understanding and control of these conditions, and the agricultural experiment station has been called on to aid in the study of these matters.

The legislature of 1902-3 passed an act May 10, 1903, appropriating the sum of \$2,500 per year, for two years, to aid in the development of the cranberry industry of the State and in carrying on investigations pertaining thereto. The work was placed under the direction of the departments of agricultural physics and horticulture. In addition to this, we have secured aid from the General Government, and the study of the use of water in cranberry growing has been carried on by the department of agricultural physics in cooperation with the irrigation and drainage investigations of the Office of Experiment Stations of the United States Department of Agriculture.<sup>a</sup>

After looking about for a suitable tract of land for cranberry growing and experimental purposes, it was decided to accept the offer of the Wisconsin Cranberry Growers' Association of their station for a nominal consideration, and a lease was executed for a period of fifteen years, at the option of the University of Wisconsin. This station is located in the center of a large, important cranberry-growing section, about 11 miles southwest of Grand Rapids and 4 miles north of Cranmoor, a station on the Chicago, Milwaukee and St. Paul Railroad. The tract consists of about 10 acres, a small portion being elevated somewhat above the general level of the marsh.

---

<sup>a</sup> See Wisconsin Sta. Bul. 119.



Upon this elevation a two-room cottage was erected, serving as an office and room for the attendants.

The Cranberry Growers' Association had on this station some 150 so-called varieties of cranberries, collected from different parts of the world. These and other cranberry vines were included in the lease. Thus it will be seen that the university was materially aided by having a large amount of the pioneer work started.

Due to the lateness of the time at which the bill was passed, little but preliminary work could be done the first year. It was necessary to get the marsh into a suitable condition for planting and experimental work. The problem of adequate drainage and water supply had to be solved. Ditching, scalping, and sanding had to be done preparatory to beginning the investigation. Most of this preparatory work was finished at the beginning of the present season.

### **CONDITIONS NECESSARY FOR CRANBERRY GROWING.**

Raising cranberries, like raising all other small fruit, requires a large expenditure of capital and labor on a small area of ground. It is, therefore, of the utmost importance that the location be carefully selected with reference to the conditions essential for successful cranberry growing, which are, first, a proper soil; second, a sufficient supply of suitable water; third, adequate drainage; fourth, suitable topography for handling water, and, fifth, accessibility to railroad and other means of communication.

### **SOIL AND FERTILIZERS.**

The cranberry plant will grow on a wide variety of soils, but the character of the soil has a great influence on the character of the plant and amount of fruit produced. When grown on clay or other fertile soil, the plant usually makes a heavy growth of vines but does not fruit well, and there is a growth of weeds which are expensive to eradicate and endanger the cranberry itself. This fact makes it desirable to grow the cranberry on sand, light muck, or peat. Of these, peat is far the most desirable and is the soil on which cranberries are chiefly raised. The peat is best adapted to this plant because the topography is usually admirably adapted to the use of water, and because it is so easily ditched and affords good material for the construction of the dams and dikes required, as well as because the acidity of this soil seems favorable to the growth and fruiting of cranberry vines.

The peat varies in depth and coarseness from a few inches to 10 or 12 feet, or even more, and through all stages of decomposition from coarse, loose sphagnum moss, from which it is very largely formed, through the finer and more compact forms of peat to the

decomposed form of muck. The growth and fruiting of the cranberries are very largely influenced by the character of the peat on which they are grown. In general, the coarser and deeper the peat the more rank and vigorous is the growth of the vines. It is possible that the fruiting is not quite so heavy on these coarser grades of peat, but certainly in many instances extremely heavy crops have been raised on very coarse peat.

It is desirable that the soil of the whole of each plat be of a uniform character, both as to depth of peat and texture; the first, in order that there may not be unequal settling of the ground, leaving it uneven, and the second, in order that the berries may come to maturity at the same time over the whole plat.

The cranberry fruit contains a relatively small amount of dry matter, varying from 8 to 15 per cent, and of this dry matter only about 2 per cent is ash. The fruit, therefore, takes but small amounts of mineral matter from the soil. According to analyses of this ash, made by the Massachusetts and New Jersey experiment stations, a crop of 100 barrels would take from an acre about 10 pounds of potash, 4 pounds of lime, and 3 pounds of phosphoric acid. While these amounts are not more than one-fourth what good yields of the staple farm crops take from good soil, it must be remembered that in the condition in which cranberry bogs are kept the amount of these elements which become available to plants each year is comparatively small. It is therefore quite possible that the use of moderate amounts of artificial fertilizers may be necessary to continuously secure good yields. This has been the experience on the bogs of Cape Cod, where intensified cultivation has been rewarded with very large yields. Experiments on the use of fertilizers have been begun on the station, but have not had time to give definite results.

#### **IRRIGATION, DRAINAGE, AND SANDING AS A MEANS OF PROTECTION FROM FROST.**

The passing of cold waves, with the attending possibility of frost, is a matter of grave importance to the cranberry grower. In fact, so injurious are these cold waves and frosts in cranberry culture that the one great aim of cranberry growers in this State has been to secure means of protection against frosts and better methods of foretelling them. The importance of this matter can be better understood when it is known that on the night of August 8, 1904, a loss was sustained, by a frost which came unexpectedly, to the extent of about 60 per cent of the entire crop, amounting in value to approximately \$200,000.

#### **WEATHER FORECASTING.**

During the past year the United States Weather Bureau has undertaken to furnish special forecasts to these regions, and for this pur-

pose established three or four special stations over the moorlands of the central part of the State. Daily reports were sent from each of these stations to the central station at Chicago, and whenever the conditions were such as to indicate the probability of frost special warnings were sent to each of these stations for the benefit of the cranberry growers. However, as only the ordinary reports were sent from these stations their forecasts could be made only as they are made for other places—that is, a forecast of the weather that would probably follow the movement of general cyclonic waves.

A comparison of the temperatures at any of the marsh stations with those of a highland station, as at La Crosse, shows that while the minimum temperatures over the marsh region are affected in general by these cyclonic waves there are local conditions which have a much greater effect in producing frost. This subject will be discussed later.

#### **LOCAL CONDITIONS WHICH INFLUENCE FROST FORMATION.**

It is a matter of common experience that the air in hollows and small valleys becomes cooler during the night in the summer and that frosts are much more likely to occur in such places than on the surrounding higher lands. However, this can not account for the fact that frost often does not occur uniformly over a broad, level moorland, but forms in patches. Careful observation during the past season has brought out the fact that these patches of frost are where the marsh is poorly drained or covered with weeds, grass, and moss, while often clean, well-drained, or sanded land escaped. It is thus quite evident that local conditions over the level marsh regions are the controlling factors in frost formation.

That local conditions as well as general meteorological conditions must be studied in determining the probability of a frost is shown also by the great fluctuation in the variation of the minimum temperatures between Grand Rapids, located on the hard land along the Wisconsin River, and the State experiment station, 10 miles west, in the center of the Cranmoor moorland tract. The daily reports during the first four days of the month of July of the past year showed the variation of the minimum temperatures between these two places to be  $7^{\circ}$  to  $10^{\circ}$  F., while on the next day, without any apparent cause, the difference reached  $23^{\circ}$ , coming back again to a difference of  $3^{\circ}$  on the night of the 6th. A comparison of the minimum temperatures during the month of August, 1904, between the marsh stations and those of the hard lands show many such variations. These temperatures are given in the following table. Appleton Marsh, City Point, and Cranberry Experiment Station are located on the marsh, or moorland tracts. Grand Rapids is located on the high land about 10 miles east of the Cranberry Experiment Station, and La Crosse is located on high land about 75 miles west and a little south of the Cranberry Experiment

Station. These stations are all within a region which would be included in a single general prediction.

Maximum and minimum temperatures and variations for August, 1904.

Day.	Maximum.					Minimum.					Variation.				
	Appleton Marsh.	City Point.	Grand Rapids.	Cranberry Experiment Station.	La Crosse.	Appleton Marsh.	City Point.	Grand Rapids.	Cranberry Experiment Station.	La Crosse.	Appleton Marsh.	City Point.	Grand Rapids.	Cranberry Experiment Station.	La Crosse.
1	75	78	74	76	75	54	49	55	41	58	21	29	19	35	17
2	77	78	73	77	79	44	38	41	32	50	33	40	24	45	20
3	78	79	79	81	76	43	43	49	37	55	36	36	30	44	21
4	75	77	73	77	76	59	59	54	51	62	16	18	19	24	14
5	78	85	78	84	87	55	55	54	40	58	29	34	24	44	20
6	76	77	71	76	77	54	50	51	37	58	22	27	26	30	19
7	65	65	71	67	67	50	48	48	42	52	15	17	20	25	15
8	71	71	70	75	71	28	30	37	26	48	13	13	33	49	23
9	69	58	68	58	65	46	41	47	47	57	43	17	16	11	8
10	74	75	71	76	72	51	40	53	53	54	23	35	18	23	18
11	75	76	77	78	75	34	30	43	36	50	24	29	34	43	25
12	82	88	86	90	90	50	39	55	49	64	38	49	41	26	26
13	80	81	81	81	81	62	42	67	55	62	18	40	18	26	19
14	84	84	81	86	86	44	41	48	36	64	40	43	33	50	32
15	85	85	85	88	84	57	54	58	47	65	14	28	27	41	19
16	85	85	83	86	86	54	51	54	43	60	31	34	29	41	26
17	68	67	79	68	73	54	43	43	40	57	14	24	27	28	16
18	75	77	75	77	76	45	48	49	41	52	30	29	26	36	24
19	73	74	71	73	75	49	49	53	42	60	24	25	18	31	15
20	82	81	82	85	82	49	49	55	45	56	33	32	27	40	26
21	78	80	80	81	77	59	43	65	56	61	19	37	15	25	16
22	74	73	74	75	75	43	44	45	30	50	31	29	29	45	26
23	78	80	77	78	79	40	37	45	50	50	38	43	32	47	29
24	87	88	87	88	81	53	49	54	42	60	34	39	33	46	31
25	69	69	86	69	83	60	59	61	54	54	9	10	25	15	20
26	77	78	78	78	74	41	34	42	32	32	36	44	34	46	47
27	81	83	80	83	82	49	49	45	52	36	38	38	28	47	26
28	78	75	78	73	73	58	55	60	44	61	20	20	18	29	24
29	70	70	68	70	66	25	35	54	50	56	15	15	15	20	10
30	73	71	70	72	73	25	35	42	29	50	48	36	28	43	23
31	77	77	75	77	75	44	51	51	49	57	33	26	24	28	18
Monthly mean.	76.5	76.9	77.1	77.5	78	48.9	45.5	51.9	41.7	55.8					

The conditions which determine the absorption of radiant energy by the earth and its radiation during the night are the conditions which mainly control the formation of frost. The two factors most prominent in this absorption of terrestrial radiation are water vapor and carbon dioxide. Just what part each plays in this absorption has been a matter of considerable study, and as yet but little is known as to their comparative values.

**INFLUENCE OF HUMIDITY ON THE OCCURRENCE OF FROST.**

The statement very commonly made that night frosts occur only with a clear sky and dry air does not always hold true in marsh regions. On the night of June 12, 1903, a killing frost occurred over the moorlands in central Wood County, although the point of saturation was reached at  $45^{\circ}$ . This was determined early in the evening with a wet and dry bulb thermometer and later by direct observation when the temperature of  $45^{\circ}$  was reached, and although this condition was reached by 8 o'clock that night water was freezing over the surface of the marshes before 12 o'clock. The temperature curve for this night was apparently unaffected when the saturation point was reached. Either the condition which produces absorption of heat in the atmosphere, thus keeping up its temperature, must have been abnormally low on this night or else the factor which dissipates this heat as radiant energy must have been abnormally active, because the amount of moisture is known ordinarily to be a large factor in determining the minimum temperature of the night. This is due not only to the amount of latent heat given up in the condensation of the moisture, but also to the aid of this moisture in the air in absorbing the heat which is radiated from the soil.

It will thus be seen that while the determination of the dew point can not be relied upon absolutely in forecasting frost, it is often a great help and convenience to know it. For the benefit of those who desire to use this method a brief outline and table for the determination are herewith given. The apparatus consists of two thermometers mounted together, one with a wet and one with a dry bulb. To determine the dew point, or point of saturation, with a palm-leaf fan or some other similar device keep the air in rapid motion about the bulbs of the two thermometers until the mercury threads in the stems have become stationary. The evaporation from the bulb of the wet-bulb thermometer will absorb the heat from the bulb itself, thus causing this thermometer to fall below the temperature of the dry bulb if the point of saturation has not already been reached in the surrounding air. The difference in temperature as shown by the two thermometers is noted and from the accompanying table the dew point—that is, the temperature at which the dew will begin to fall—may be determined. For example, if the difference between the wet and dry bulbs be  $4^{\circ}$  and the temperature of the air—that is, of the dry bulb—be  $55^{\circ}$ , follow the column headed  $4^{\circ}$  down to opposite the number 55 in the outside column of the table. The number located in this way indicates the dew point— $48^{\circ}$  in this case.

*Deic-point table, Fahrenheit temperatures.*

Dry thermometer.	Difference between the dry and wet thermometers ( <i>t-t'</i> ).												Dry thermometer.
	1°.	2°.	3°.	4°.	5°.	6°.	7°.	8°.	9°.	10°.	11°.	12°.	
35	32	30	28	25	22								35
36	34	31	29	26	23								36
37	35	32	30	27	24	21							37
38	36	33	31	28	26	22							38
39	37	34	32	29	27	24							39
40	38	35	33	30	28	25	22						40
41	39	36	34	32	29	26	23						41
42	40	38	35	33	30	27	24						42
43	41	39	36	34	31	29	26	23					43
44	42	40	37	35	32	30	27	24					44
45	43	41	39	36	33	31	28	25	22				45
46	44	42	40	37	35	32	30	27	24				46
47	45	43	41	39	36	33	31	28	25				47
48	46	44	42	40	37	35	32	29	26	23			48
49	47	45	43	41	38	36	33	31	28	25			49
50	48	46	44	42	40	37	34	32	29	26			50
51	49	47	45	43	41	38	36	33	31	28	24		51
52	50	48	46	44	42	40	37	34	32	29	26		52
53	51	49	47	45	43	41	38	36	33	30	28		53
54	52	50	49	46	44	42	40	37	34	32	29		54
55	53	52	50	48	46	43	41	39	36	33	30	28	55
56	54	53	51	49	47	44	42	40	37	34	32	29	56
57	55	54	52	50	48	46	44	41	39	36	33	30	57
58	56	55	53	51	49	47	45	42	40	37	35	32	58
59	57	56	54	52	50	48	46	44	41	39	36	33	59

The daily variation in temperature over marsh regions is usually supposed to be less than that over surrounding highlands, due to cooling by evaporation during the day and the keeping up of the temperature by condensation during the night. However, the daily variations given in the table on page 629 show that the range is greater at the Appleton Marsh, City Point, and the Cranberry Experiment Station than at the highland stations, Grand Rapids and La Crosse. The most striking difference is noticed between Grand Rapids and the Cranberry Experiment Station, two stations located only about 10 miles apart, thus being affected the same by general storm movements, the difference recorded being due alone to local conditions. The daily maximum and minimum temperatures for these places show that the minimum temperature is not only lower at the marsh stations, but that the maximum was in most cases higher at these points than at the adjacent highland stations. The local conditions which produce these effects can not with our present knowledge be accounted for. Whatever these local conditions may be, they are probably beyond our control.

**MEANS FOR PREVENTION OF FROST.**

There are many things in the practical operation of a cranberry marsh which may be done to help control temperatures. We have seen that, while the local conditions of the atmosphere have much to do with the control of temperature by the absorption of heat, the earth is the source from which this heat comes, and while we can not control the factors which affect absorption by the air, we can, in a

measure, influence the absorption and radiation by the soil. It is evident that in order to secure the most favorable conditions for both absorption and radiation it is necessary to keep the ground as free from covering as possible. The tables of minimum temperatures for July and August, taken over bare, sanded bog in one case and over a bog covered with a mat of grass and vines in the other, show a variation as high as 13° in favor of the bare, sanded bog. Minimum temperatures on the Gaynor Blackstone marsh, where the bog is covered with a sort of blanket of dead grass and growing vegetation, show temperatures at most times a little below those on the bog covered with clean vines. These facts are shown in the following table:

*Minimum temperatures over bare, sanded plats and adjacent plats covered with dead grass, matted vines, and growing vegetation.*

Date.	Minimum temperature over bare, sanded bog.	Minimum temperature over bog covered with mat of grass and vines.	Date.	Minimum temperature over bare, sanded bog.	Minimum temperature over bog covered with mat of grass and vines.
	° F.	° F.		° F.	° F.
July 1 .....	42	33.5	August 1 .....	49	41
2 .....	40	32	2 .....	43	32
3 .....	49	44	3 .....	51	37.5
4 .....	54	54	4 .....	52	51
5 .....	50	41	5 .....	49	40
6 .....	57	54.5	6 .....	45	37
7 .....	54	47.5	7 .....	48	42
8 .....	55	54	8 .....	34	26
9 .....	56	50.5	9 .....	51	47
10 .....	51	43	10 .....	52	53
11 .....	54	45.5	11 .....	40	35
12 .....	49	36	12 .....	54.5	49
13 .....	49	39	13 .....	62	55
14 .....	50	57.5	14 .....	44	36
15 .....	47	37.5	15 .....	54	47
16 .....	54	43	16 .....	54	43
17 .....	60	63.5	17 .....	48	39.5
18 .....	62.5	59	18 .....	45.5	41
19 .....	57	57	19 .....	48.5	42
20 .....	48	39	20 .....	50.5	45
21 .....	47	37.5	21 .....	56.5	55
22 .....	48.5	36.5	22 .....	40	30.5
23 .....	45	33	23 .....	37	30
24 .....	44.5	35	24 .....	47	42.5
25 .....	49	39	25 .....	57	54
26 .....	58	52	26 .....	36.5	32
27 .....	49	36	27 .....	45	36
28 .....	48	36	28 .....	53	44
29 .....	51	39	29 .....	54	50
30 .....	53	53	30 .....	37	28.5
31 .....	49.5	39.5	31 .....	50	49

The data given in comparison of the temperatures over bare, sanded bog and bog covered with grass and growing vegetation, showing a difference in temperature in favor of the sanded bog, can not be considered to mean that the covering in the one case was the sole cause of difference. The low specific heat of sand and the consequent high heating of it during days of sunshine, and also the lack of evaporation over its surface because of the lack of capillarity for bringing water to the surface render it especially valuable as a

conservator of heat. It will thus be seen that sanding and keeping free from weeds, grasses, or any form of useless vegetation over the bog are two very important factors in protection from frost, especially on newly planted bogs.

#### DRAINAGE.

There is a third condition, and one wholly within the control of all cranberry growers, which is perhaps of greater importance than all the others together as a means of frost protection—that is, drainage. The effect of thorough drainage by the use of deep and close ditches in aiding in protection from frost can hardly be overvalued. The State experiment station has gone through the past summer, in which there were several frosts and one or two very hard frosts, without any loss from freezing whatever, notwithstanding the fact that certain parts of the bog were not flooded once during the season. On other adjoining marshes flooding was resorted to many times during the summer for protection, and yet a loss of about 60 per cent of the total crop was sustained on the morning of August 8. While this protection on the station was not due to good drainage alone, there is no doubt that it had much to do with warding off the frost. And the three conditions above mentioned—that is, good drainage, sanding, and freedom from excessive vegetation—are the only conditions which could account for this extra protection to the station. The influence of these factors on the temperature of the soil and of the air above it is very clearly shown in the following tables of temperatures. All of these plats are within a few rods of each other.

Section A, plat 1, was well vined, free from weeds, and had good drainage. Section B, plat 8, was well vined, free from weeds, but had water held at the surface. The sand section had no vines, no growing vegetation, and good drainage. Company marsh was well vined, had poor drainage, and was heavily covered with a mat of old vines and vegetation.

*Hourly temperatures of night of frost.*

Hour.	Section A, plat 1.	Section B, plat 8.	Sand section.	Company marsh.
<b>Aug. 22-23:</b>	° F.	° F.	° F.	° F.
9.30 p. m. ....	42	43	50	33.5
10.30 p. m. ....	39.5	41	47	33.3
11.30 p. m. ....	38	39.5	44.5	31.5
12.30 p. m. ....	37.5	39	43.5	30
1.30 a. m. ....	36.3	36.5	42	29.7
2.30 a. m. ....	35.5	36	40.5	32.5
4.30 a. m. ....	34	35	40	36.5
<b>Aug. 29-30:</b>				
7.45 p. m. ....	40	43	48	36
9.15 p. m. ....	38.5	41.5	45	38
10.30 p. m. ....	35	38	42.5	33.5
11.30 p. m. ....	34	37	40.5	29
12.40 a. m. ....	34	36	39.5	31
2.30 a. m. ....	37	37.5	39.5	34
6 a. m. ....	39.5	41.5	44.5	46.5



The table following shows the relative rate of fall in the temperature of the atmosphere at different heights over bog held under different conditions.

Section A, plat 1, was well vined, free from weeds, and had good drainage.

Section B, plat 1, was well vined, free from weeds, and had good drainage.

Sand section had no vines, no vegetation, and good drainage.

Section B, plat 8, was well vined, free from weeds, and had water held at the surface.

*Hourly temperatures of air on night of frost.*

Hour.	1 inch above surface.				1 foot above surface.		
	Section A, plat 1.	Section B, plat 1.	Sand sec- tion.	Section B, plat 8.	Company marsh.	Section B, plat 8.	Company marsh.
September 13-14:	° F.	° F.	° F.	° F.	° F.	° F.	° F.
7.15 p. m. ....	40.5	41.5	44	39	39	43	42
8.25 p. m. ....	35	38	40.5	35	36	39	39
9.20 p. m. ....	34	35.5	38.5	33.5	37.5	37.5	37.5
10.20 p. m. ....	31	32.5	35	28.5	31	34	34
11.20 p. m. ....	31.5	32	34	28	32	33	31.5
2 a. m. ....	31.5	32	35	30.5	32	34	34
3.15 a. m. ....	31.5	33	36	31.5	32.5	35	35.5
5.40 a. m. ....	37	39	40	37	40	40	40.5
6.40 a. m. ....	40.5	41.5	42	39	42.5	42	42.5
8.20 a. m. ....	46.5	48	47	45	51.5	46.5	47.5
9.20 a. m. ....	50	51	52	52.5	57	52.5	52
September 14-15:							
6.15 p. m. ....	35.5	38	43	34	35.5	41	37
7.15 p. m. ....	31.5	34.5	40	31.5	32	38	36
8.25 p. m. ....	28.5	31.5	37	27	28	35	29
9.50 p. m. ....	27	29	34	26	26.5	32	29
10.50 p. m. ....	27	40	33	26.5	26	31.5	27
12.20 a. m. ....	28	41	33	24	24	31	27
2.50 a. m. ....	24.5	35	29	22	26.5	27	27
4 a. m. ....	24	34	29.5	21	22	28	23
5 a. m. ....	22	32.5	28	20	21	26.5	22

The following table shows the relative rate at which the soil loses its heat under different conditions, the higher rate being more conducive to the keeping up of the temperature of the atmosphere.

Section B, plat 1, was a section of vines free from weeds and well drained. Section B, plat 8, was a section of vines free from weeds, but with the water held at the surface. Company marsh was a section of vines poorly drained and with a heavy covering of old dead grass and thickly growing vegetation. Bare peat was a section well drained and with the bare peat bog exposed. Under-moss temperature taken on a section heavily covered with sphagnum moss.

Soil temperatures below surface.

Hour.	Section B, plat 1.		Section B, plat 8.		Company marsh.		Bare peat.		Under moss.	
	1 inch.	3 inches.	1 inch.	3 inches.	1 inch.	3 inches.	1 inch.	3 inches.	1 inch.	3 inches.
September 13-14:	° F.	° F.	° F.	° F.	° F.	° F.	° F.	° F.	° F.	° F.
7.15-8.30 p. m. ....	53.5	53	53	56	55	55	52	54	54	61
9.30-10 p. m. ....	51.5	55	50	54.5	53.5	55	48.5	51	56.5	60
10.30-11 p. m. ....	49	54	50.5	53	52	54	48	55	55.5	59
2.30-3 a. m. ....	47.5	52	49	51	50	53	46	52	52	51.5
5.45-6.30 a. m. ....	47	52	46.5	51.5	50.5	53	47	52	55	58
8.40-9 a. m. ....	50	51.5	49	50	51.5	53	49.5	53	56	53.
September 14-15:										
7.30-8.30 p. m. ....	50	54	50	53	52	56	51	57	58.5	60
10.30-11.30 p. m. ....	48	51	47	51	48.5	51.5	47.5	52	56	59
3-4 a. m. ....	43	46	40	47	47	50	40	49	57	59
September 11-12:										
7.25-9 p. m. ....	60	60.5	59	60	58	58	59	64	62	64
10.30-11.30 p. m. ....	54.5	57.5	56	58.5	57	58.5	54	62	61	63
12.30-2 a. m. ....	51	57	52.5	53	56.5	55	48.5	60	60.5	63
4.30 a. m. ....	51.5	53.5	49	56.5	50	54.5	48	55	56	58
September 12-13:										
6.15-6.35 p. m. ....	60	59.5	60	61.5	57.5	57	62	66.5	63	63
7.30-8.20 p. m. ....	58.5	60	58.5	60.5	57.5	57	58	65	60.5	61.5
5.45-6.30 a. m. ....	54	56.5	55	57.5	54	56	54	60	60	62.5
7.45 a. m. ....	54.5	56	54.5	56.5	55	56	54.5	58	58	60

FLOODING.

The sole method used heretofore throughout the State of Wisconsin for protection against frost has been that of flooding the marshes with water. This method, where the system for handling the water is so arranged that it may be done rapidly and where the temperature of the water is sufficiently high, has proved very efficient, and will doubtless always remain the surest protection against severe frost, but it may oftentimes be used, and undoubtedly is used, to the very serious damage of the crop. This, of course, means a thorough flooding of the marsh or a flooding where it is necessary to put the berries under water. However, such heavy flooding is necessary only during the later part of the season, when hard frosts occur, and this method of protection may be well and safely used for the occasional and untimely frosts of summer. At such times it is seldom necessary to raise the water over the surface, especially if the flooding ditches are close together, for the high temperature of the water at this season and its high specific heat make a small amount ample for protection against light frosts.

**CHARACTER, STORAGE, AND MANAGEMENT OF THE WATER SUPPLY.**

**CHARACTER OF WATER.**

The major part of the cranberry lands of Wisconsin lies in broad, level tracts and the most easily available water supply for protection against frost is the surface water which is held back or stored

from the melting winter snows or from heavy rains. These lands being formed mostly of peat and muck on sand subsoil, the water which is stored is free from lime, and there is a popular belief among cranberry growers that lime is detrimental to the growth of the plants and to production of fruit. An experiment to test this point is now being carried on at the experiment station, where slaked lime has been applied to several square rods of new planting, the aim being to neutralize the acidity of the soil and leave the water to be taken up by the plant with the lime in solution. A similar experiment with the same purpose in view is being carried on with the use of marl, which contains a high percentage of carbonate of lime, in place of the air-slaked lime. The applications in both cases were made about the middle of June and at the end of the season no effect could be observed on the growth of the young plants.

#### **SOURCE OF WATER AND LOCATION OF RESERVOIR DAM.**

The method used in storing water varies with the conditions under which it is collected. A few marshes throughout the State and several which might be developed have a natural supply in the form of lakes. All that is necessary in such cases to secure a sufficient water supply is to construct a dam across the outlet. In many cases old mill dams already constructed might be utilized to advantage for this purpose. Such reservoirs are cheaply constructed, and where the supply from the lake is sufficient to offset the evaporation and seepage give a sure and valuable water supply. A number of such locations, as yet undeveloped, are to be found throughout the State, although the amount of marsh which could be developed is in most cases small, and in some cases pumping for drainage would be necessary. There are also a number of marshes, developed and undeveloped, which have a flowing stream for a water supply. Such supplies are valuable because of their constancy, although a lack of irrigation laws in this State has allowed much controversy, and in some cases has led to expensive litigation.

Since the principal part of the cranberry moors is supplied by surface water only, it is necessary to build dikes across the fall of the country to form reservoirs or catch basins in which to catch this surface water and seepage after heavy rains or melting snows. As this is necessarily expensive work and as the success in cranberry culture depends much upon the character of the water supply, care should be taken in selecting the location and determining the direction and size of the dam. In several instances in this State dams have been constructed at heavy expense without any preliminary work to determine the direction of the fall of the country or character of the bottom of exposed reservoirs. In some instances where the guess in these matters happened to be a lucky one the reservoirs have proven

quite efficient; in others where the guess was not so good the dams have been constructed partially in the direction of the fall of the country or too near a watershed, and a greater part of the work has been thrown away. In still other cases dams have been constructed 4 to 5 feet in height when a dam of half that height would have held water at the surface at the upper end of the owner's land or at least as high as consistent with successful drainage for the person above. A man may unknowingly be using the bog of his neighbor's marsh above as a storage reservoir. Misconstruction entails needless expense, in many cases amounting to thousands of dollars thrown away in useless labor, all of which might be saved by a few dollars spent in preliminary leveling over the tract proposed to be used for the reservoir. Simple analysis of the soil of the bogs would in most cases suffice to show the probable seepage through the bottom and the head of water which could be most economically held.

#### CONSTRUCTION OF DAMS.

Generally these dams are constructed of pieces of peat scalped from the adjacent bog or of sand hauled from the surrounding islands. If the peat is used, the bog should be scalped deep, as the expense of handling deep scalping is much less per cubic foot than of handling shallow scalping. A peat dam, with a base of 18 feet wide and a top of 10 feet wide,  $4\frac{1}{2}$  feet high, was constructed at the experiment station at an expense of \$3.95 per running rod. This dam was sanded late during the winter to a depth of 8 inches on top and with a good sand facing, at an expense of approximately \$2 per running rod. In cases where sand is used in this way for the facing of a dam, the finer the sand the better, as it is used as a sort of a filler to prevent seepage through the loose scalplings. In this case the scalplings were taken from the inside of the reservoir, the ground being scalped a second time to furnish material, making in all a scalping of about 7 inches. This deep scalping so weakened the bottom of the reservoir that when an attempt was made to hold a 3-foot head during the dry month of August this year the seepage, together with evaporation, amounted to over 3 inches per day.

It would therefore seem advisable not to disturb the matted surface within a reservoir, especially if this be of thin peat, but rather take the material from the outside. In doing this the ground should not be scalped close up to the outside of the dam, as this will have a weakening effect by increasing the perpendicular distance between the bottom of the dam and the surface of the water within the reservoir.

If the matter of economy of land or the need of roadway does not enter into the construction of dams, it is possible they may be more cheaply constructed by building them in series. In this case a dam

of the proper height and moderate width is constructed and another light dam of perhaps half the height at a distance of 10 or 12 feet below it. If the upper dam be of considerable height a third one may be added to the two. By the use of these smaller dams to catch the seepage from the ones above a counter head is held against them, and the pressure on the upper dam, instead of being that of the full head of water held against it, is only the pressure of a head equal to the difference between the water surfaces above and below.

The expense of building a sand dam depends largely upon the distance of the sand pit from the dam. The principal advantages of sand dams are their great weight and permanency. While a peat dam will settle greatly, as the peat decays and is light and easily moved by a high head of water, a sand dam, because of the nature of the material, will settle but little after its construction, and because of its great weight presses the surface of the marsh beneath it more closely, thus tending to prevent seepage. Perhaps the best dam, considering both economy of construction and utility, for the major part of the marshes of the State would be a dam constructed of peat scalplings, with a heavy covering and facing of sand, the main part of the economy coming from the fact that the ground is prepared for planting at the same time the scalplings are utilized for the construction of a reservoir.

#### **DEPTH OF WATER IN RESERVOIR.**

The depth at which it is possible to hold the water in a reservoir in this section depends chiefly upon the permeability of the soil. It is desirable that the water in the reservoir be held to considerable depth, where this is possible, in order to lessen the loss by evaporation, and yet with most of the soils over which reservoirs are necessarily constructed the permeability and consequent seepage will not permit the holding of a very high head. In fact the head which can be most economically held is determined by a sort of balance between evaporation and seepage, the adjustment being such that the loss from the combination of these two causes is a minimum. The case of the station reservoir cited above is an evidence of this fact. When the head of water held was too high for the condition of the bottom of the reservoir the seepage became very great, as described on page 637. Evaporation would be excessive only in open reservoirs, and too much spreading of water in an open reservoir with a low head might produce a much greater loss than would be sustained through seepage were the same amount of water spread over half the area with a higher head. The depth of water which can be held in any given reservoir can therefore only be told by experiment, increasing it gradually by raising the dams till the seepage exceeds the evaporation.

**LOSS BY EVAPORATION.**

In a summer like the one just passed, when the evaporation from the water surface is more than double the rainfall, the effect of spreading water over a very large area is a serious loss. For instance, where the evaporation amounts to over 7 inches of water in one month, as it did in July this year, a reservoir with a 4-foot head, covering 40 acres at the beginning of the month, would still be left at the end of the month with a good supply, having a head of over 3 feet, barring seepage, while if the same amount of water had been spread over a quarter section the evaporation during the one month would have made it practically useless. Evaporation was measured in a cylinder 3 feet in diameter and 2 feet deep, kept floating in the reservoir. The amount of evaporation during the past season is given in the following table, together with the rainfall:

*Rainfall and evaporation during June and July at the Wisconsin cranberry experiment station.*

Date.	Rain-fall.	Evap-oration.	Date.	Rain-fall.	Evap-oration.	Date.	Rain-fall.	Evap-oration.	Date.	Rain-fall.	Evap-oration.
	In.	In.		In.	In.		In.	In.		In.	In.
June 1		0.09	June 18		0.25	July 1	0.02		July 18	0.14	
2		.28	19			2		0.65	19		0.27
3	0.02		20		.85	3			20		.34
4	1.71		21		.36	4	.32	.06	21		.28
5	.36	.36	22			5	Tr.	.31	22		.01
6	.02	.40	23			6	Tr.	.16	23		.30
7			24	.65		7	.01	.15	24		.23
8			25		1.49	8	.30		25		.31
9		.35	26	.17		9	.90	.90	26	.07	.12
10		.38	27			10	Tr.		27		.25
11		.20	28		.44	11		.20	28		.29
12		.22	29	.04		12	Tr.	.26	29	.44	
13	.21	.21	30	1.01		13			30	.20	.36
14	.32	.02				14	.12	.79	31		
15		.32	Average	.16	.27	15	Tr.				
16		.42	Total	4.87	6.53	16		.38	Average	.10	.24
17		.30				17		.34	Total	3.09	7.29

**EFFECT OF GROWING VEGETATION IN RESERVOIRS.**

The exact effect of growing vegetation in reservoirs is hard to determine. While the surface presented to the air through which evaporation may take place is greatly increased by the growing vegetation, the surface of the water is protected from the wind. However, considering the amount of water ordinarily used by the growth of some of the tame grasses and supposing the ordinary marsh grasses, because of their habitat, to use as much or more water than these tame grasses, one would come to the conclusion by comparison with the evaporation from a free water surface that this growth of vegetation was detrimental to a reservoir.

**FLOATING BOG IN RESERVOIRS.**

In most of the reservoirs constructed over the peat-bog areas the bog becomes loosened from the bed of the reservoir and floats on the

surface of the water in the reservoir. While this prevents evaporation from the surface of the water and would partly overcome evaporation were it not for the vegetation growing on the floating bog, on the other hand it serves as a blanket in keeping the sun's rays from the water, thus keeping the temperature of the water low and making it of much less value in flooding against frosts. This floating of the bog also weakens the bottom of the reservoir, allowing greater seepage from beneath. The floating of the peat in a reservoir might be prevented by weighting down with sand. This plan would not, of course, be feasible where reservoirs are spread over a very large area, because of the great expense of sanding.

In reservoirs covered with floating bogs the bog does not remain in compact form, but opens out spongelike and thus becomes a serious hindrance to rapid flooding unless there be enough free water in the reservoir for one watering. On the night of August 8 on the marsh of the Cranberry Moss and Peat Company, after a hurried flooding of the marsh, which was successfully accomplished in about two hours, it appeared that the whole supply of water had been exhausted, the water of the reservoir having been reduced nearly to the level of the water in the ditches on the planting. Had there been a much larger area to flood, the crop probably would have been lost because of the lack of serviceable water, yet by 10 o'clock of the next day enough water had seeped from the floating bog of the reservoir to bring the head on the dam to within a few inches of where it was before flooding. The same condition undoubtedly prevented successful flooding of many other marshes where a large percentage of the crop was lost. In most of our reservoirs constructed on the open moorlands the only water is in the ditches dug on the inner side of the dam at the time of construction. This difficulty of too little water for serviceable flooding might be overcome by providing a larger space for open water, either by cutting away part of the floating bog or by preventing its floating.

#### **COMMUNITY RESERVOIR SYSTEMS.**

It is probable that it would be far more economical for the cranberry growers of the larger cranberry region, working together, to construct a system of closed reservoirs with better prepared bottoms, each being connected with the one above by canals. There is little doubt that the water received during the season over any of these regions is sufficient to maintain a much larger acreage than is at present maintained and have a good water supply, even in the dry seasons, were more economical flooding and drainage systems to be made use of. Of course all this would require community harmony and agreement as to water rights.

**IRRIGATION DITCHES.**

The value of a reservoir in cranberry culture depends largely upon the arrangements for getting the water onto the fields quickly. A great part of the loss sustained on the morning of August 8, 1904, which amounted to many thousands of dollars, was due to the insufficiency of the flooding system for handling water rapidly. This loss on many of the marshes, could the prospective crop have been successfully harvested, was sufficient to have provided closed reservoirs adjacent to each section of the planted marsh. The trouble with most of our marshes is not only the insufficiency of the main ditch or means of getting water to the sections, but also the lack of ditching within the sections.

The size and depth of the ditches used in conveying the water from the reservoirs and spreading it over the planting are of great importance, especially on nights of quick, heavy frost, when it is necessary to flood quickly. There should be one or more large main ditches extended from the reservoir through the planting and reaching each section, so that each may be flooded independently. The ditches should be large enough to flood the land quickly, even when water is low in the reservoir. The proper size of a ditch may be determined by computing the amount of water necessary to flood the given area and the shortest time within which it may be desirable to get this water on the land. The flow in the ditch may be determined approximately by taking the area of the cross section and multiplying by the distance which an object will float on the surface of the water during one minute. In computing the amount of water necessary to flood the given area it must be remembered that the bog, if dry, will take up considerable water.

Much energy which might help greatly in quick flooding is lost at the head of each branch ditch by allowing the water to pour over the sluice boards instead of being forced out under them, thus losing the head of pressure, which might be used to great advantage in increasing the rapidity of the flow from the main ditches into the sections. In fact, were it not for the friction of the flow on the bottom the main flooding canal might well be made by building embankments on the sides. In the construction of the canal depth rather than width should be sought because of the greater amount of friction on the bottom and the increased pressure due to depth. If the greatest efficiency would be had in flooding, the canal should be so constructed that the full head of pressure in the reservoir may be carried to the end of the flooding canal. In this case the canal might be kept filled during the season of probable frost, the only extra loss of water being that which would come from the extra surface presented for evaporation and the seepage through the embankments, an amount of little



consequence in large systems. In at least three instances in Wisconsin this year crops were damaged to the extent of many thousand dollars because of the insufficient capacity of the flooding canals. In each case the expenditure of a few hundred dollars would have constructed good substantial canals of ample capacity for flooding at all times.

As both flooding and drainage are necessary for successful cranberry culture the ditches within the smaller sections may be conveniently arranged to answer both purposes. To successfully flood against quick, heavy frosts these ditches should be of sufficient size to carry the water necessary to flood over the surface of the entire section within two hours. The table of hourly temperatures taken on the night of frost, September 13-14, show the possibility of quick frosts and the necessity of flooding within a short time after the temperature has reached a certain point where indications are pretty certain for frost. For instance, on the night of September 14 frost was forming over certain parts of the marsh within an hour after sunset. While this is too late in the season for light frost to do much damage, it shows the possibility of a quick drop in temperature and the necessity of provision for rapid flooding.

To facilitate rapidity in flooding the section should be as nearly level as possible and the small flooding and drainage ditches not more than 2 rods apart. The progress of the flow over the surface is necessarily slow because of the mass of vines through which the water must move. The direction of these ditches would in general be at right angles to the main flooding ditch and squarely across the fall of the land.

The main flooding ditches should have a bulkhead for every few inches of fall, and the gates into the sections from the main ditch should be of sufficient size and number to take the water from the main ditch as fast as it will supply it. Where there are a number of sections to be flooded some, of course, below others along the main ditch, the head of water in the ditch is reduced so that if the gates be all of the same size the upper sections will get more than their proportionate share of the water. This will not only waste water on the upper sections but retard flooding on the lower ones. Where the rate of flow in the ditch and size of sections to be flooded are known computations may be made and the exact size of the gates for each section determined in order that all may be flooded with equal rapidity.

#### ACKNOWLEDGMENTS.

The writer acknowledges the assistance of Mr. G. P. Haskins, who has been in charge of the details of this work, and of Mr. O. G. Malde, who has been exceptionally careful in performing the labor on the experimental ground.

# REPORT OF DRAINAGE INVESTIGATIONS, 1904.

By C. G. ELLIOTT, *Drainage Engineer.*

## INTRODUCTION.

Drainage investigations as conducted during the past year have included the consideration of questions pertaining to farm and field drainage as well as the larger projects requiring the united action of many landowners under provisions of State laws. In view of the fact that drainage is an essential factor in the productive value of farm lands, it is important that the best information upon the theory and practice of drainage for agriculture should be made available to all who desire a knowledge of this subject. Personal examinations of conditions, and in some cases surveys, have been made by engineers connected with this Office in order to render needed assistance and promote and encourage the best practice. The following outline presents the work of this Office relating to the drainage and protection of agricultural lands:

The construction of the larger works in the Middle West is quite often necessary before thorough farm drainage, which is the object ultimately sought, can be successfully accomplished. The annual rainfall for a few years preceding 1902 was below the normal, while since that date it has exceeded the average and has been unevenly distributed. It has been observed that the field drains put in during the seasons of light rainfall are in many instances inadequate for the service required by reason of insufficient outlets. The years of large rainfall have taught in a most emphatic manner that more careful attention should be given to the construction and improvement of main drainage channels and to their subsequent care and maintenance. It is also found in some of the localities where drainage work was first done, and which for a term of years was satisfactory to landowners, that better work in field construction, more complete outlets, and in some cases a general revision and reconstruction of the work done in former years are now being carried out. A study of the necessities of such localities has been made in Indiana.

Coon River drainage district, Buena Vista County, Iowa, was examined and plans proposed. This district includes the land at the headwaters of Coon River, 25,000 acres of which will be benefited by the proposed improvements, estimated to cost \$150,000. The water from an area of 128,000 acres must be provided for by the improve-

ment of natural water courses in such a manner that the lower lands will not be injured by flooding.

Soldier River cut-off and other improvements in Harrison County, Iowa, proposed for the protection and drainage of 33,000 acres of Missouri River bottom lands and estimated to cost \$111,000, have been carefully examined and reported upon.

The plans for the proposed main drainage channels for the improvement of 43,000 acres of river-bottom lands in Burt County, Nebr., to cost \$98,000, have been reviewed with the local engineers. An investigation of the best methods to be followed in the subsequent drainage of individual farms in that locality was also made and presented to the landowners at a conference called for that purpose.

The improvement of Nemaha River in Richardson County, Nebr., for the protection of 30,000 acres of lowland from overflow, has received a preliminary examination. The estimated cost is \$205,000.

Wisconsin has large areas of marsh lands, some of which have been drained and brought under cultivation. An examination of a district organized in Marathon, Portage, and Wood counties and consisting of 32,000 acres of muck and peat marsh land, the proposed drainage of which is estimated to cost \$192,000, was made and some of the peculiar features reported upon quite fully.

An important work is contemplated in Clay and Yankton counties, S. Dak., involving the drainage of 70,000 acres of bottom land. By special request a preliminary survey was made by this Office from which plans and estimate of cost were developed. Suggestions were offered regarding State legislation needed to enable owners to unite and execute this and other similar large drainage projects.

A careful examination has been made of the methods of protecting the fertile farm lands along the bottoms of the Illinois River from Peoria to Kampsville by means of levees and of the best methods of drainage applicable to such lands.

The methods used and the cost of cleaning dredge ditches and their behavior when constructed through sandy land in different localities are matters which have received attention.

Surveys and plans have been made for the drainage of 2,000 acres of cotton land in the Yazoo Delta, Mississippi, where an experiment station for the purpose of testing the efficiency of tile drains in the heavy soils of that locality is located.

A preliminary examination of a portion of the Everglades, in Dade County, Fla., was made in conjunction with the Bureau of Plant Industry, U. S. Department of Agriculture, with a view to draining a field for experimental purposes, and a report with the plan proposed for such drainage has been submitted.

Investigations of a special character were made in Cache, Washington, and Emery counties, Utah, where lands under irrigation have

been seriously injured by seepage water and alkali. An experiment at Hyde Park, Cache County, was begun in September, 1904, to determine the most efficient plan of draining seeped lands not yet injured by alkali. This Office cooperates with the owners of the land and the State experiment station in conducting this work.

Soil-water records have been kept at Hyde Park and also at Huntington, in Emery County, Utah, Fresno, Cal., and Sunnyside, Wash.

Investigations in Indiana have included special examinations of levees and reclaimed lands along the Wabash River and of farms in the upper Wabash Valley which have been till drained. The object of the latter investigation was to ascertain the ordinary drainage practice of farmers in the section mentioned.

A detailed discussion of all the questions which have received attention from this Office during the year is not attempted in this report. A variety of these problems has been considered, all of them important in the localities where the examinations were made, but as some are covered in their essential points by the treatment of similar ones which have received attention elsewhere, it is not thought necessary to discuss them all in detail. Some investigations are of a tentative character, the results of which will be given in a future report.

The field work for this report has been done as follows: John T. Stewart prepared reports on the reclamation of overflowed lands along the Missouri River in South Dakota and along the Mississippi and Illinois rivers; Prof. W. D. Pence, of Purdue University, studied the levees along the Wabash River in Indiana and farm drainage along the upper Wabash; A. B. Collins reported on the excavation of ditches through sandy lands in Missouri. In addition, all of these agents have given advice in individual cases, where farmers have applied to them for aid.

#### **GROUND-WATER RECORDS.**

The rise of ground water can be detected easily by the aid of test wells. The wells are used as gauges for determining the upper limit of the saturated soil, the surface of the water in them corresponding to the water line of the soil. Measurements made at any time indicate the relation of the water plane to the surface of the ground and a series of such measurements shows the rate of the rise of ground water, giving the data for determining the quantity of water which must be removed by drainage. The test wells at Fresno, Cal., are wooden boxes 6 inches square and 8 feet long, placed in the ground with their tops nearly flush with the surface. The distance from the surface of the ground to the water surface in the wells has been measured once and a part of the time twice each week during the irrigating season. The records of these wells for the season form an instructive study and should be considered in connection with those secured last year.

The basis used for the estimate of the quantity of water which should be removed from this soil is the volume of its interspace.

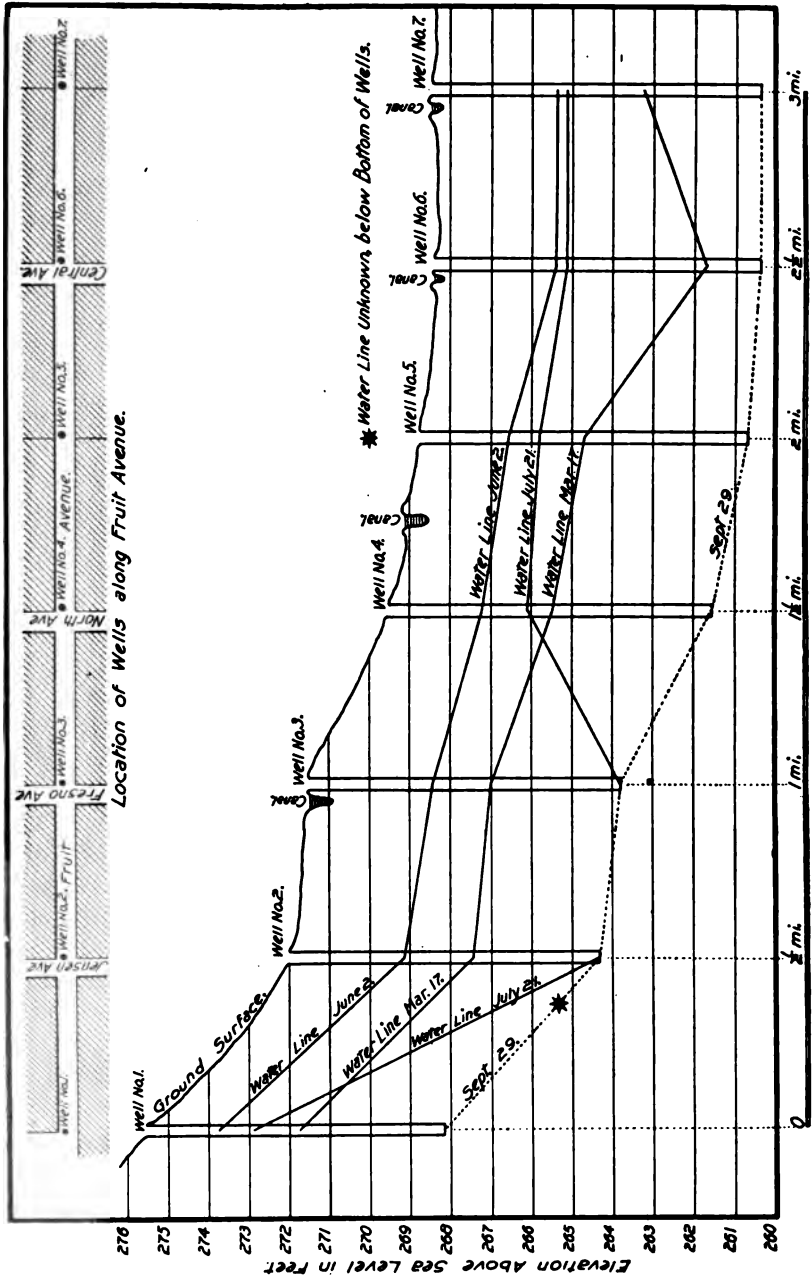

FIG. 78.—Diagram showing rise of ground water near Fresno, Cal.

This is found to be about 55 per cent by volume, which when filled with water produces a saturated soil, but when filled with air only

an arid soil. Twenty-five per cent by volume is capillary space and the water retained by it, termed "capillary water," is required for

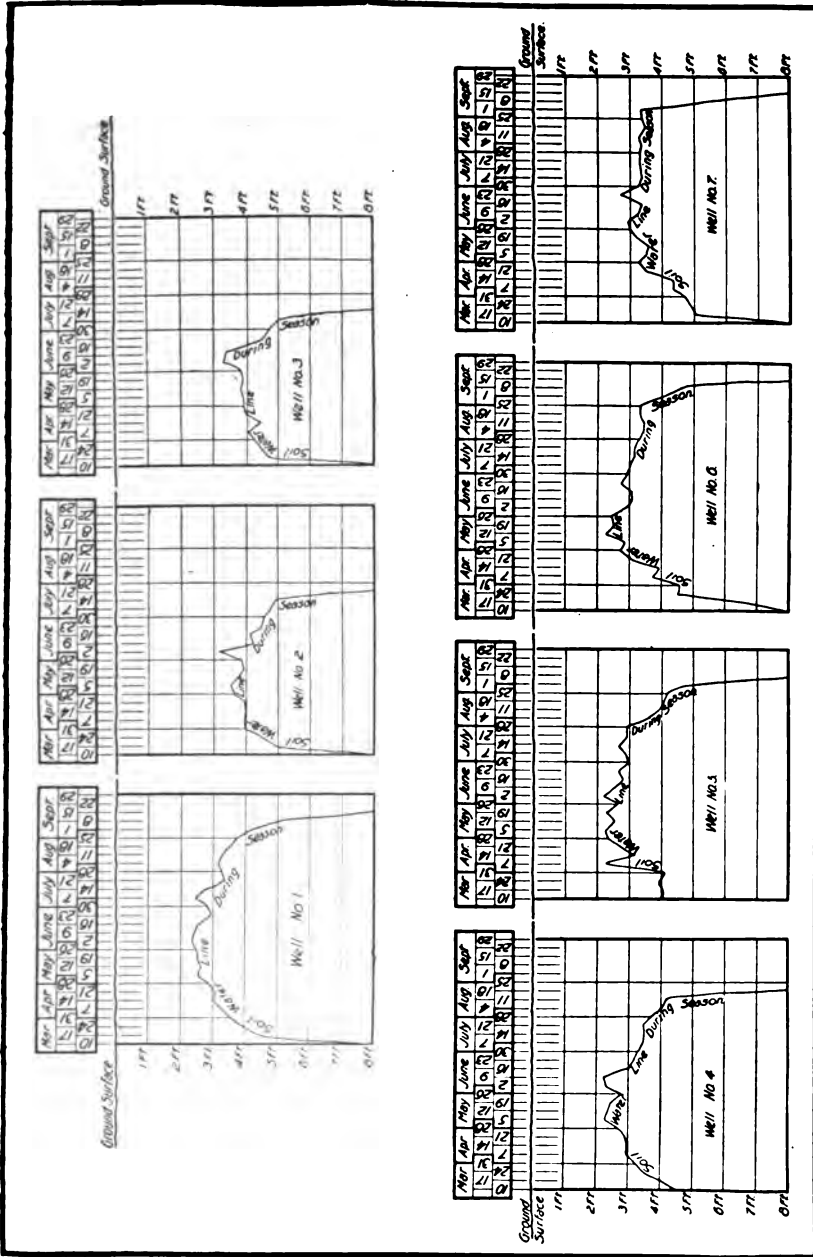

Fig. 79.—Weekly record of ground water levels, at Fresno, Cal., 1904.

plant growth. When the remaining space is filled with water the soil is saturated, this 30 per cent representing the quantity which

should be removed by drainage. A graphical representation of these conditions is shown in figure 78, and the water curves of each of the seven Fresno wells, together with the line to which drainage should reduce the water table, are shown in figure 79.

The problem which here engages our attention is to ascertain the amount of drainage water which must be handled and the method of controlling the rise of soil water which the records show takes place during the irrigating season. The average daily rise of ground water in the Fresno district from March 17 to June 2, when the ground water began to fall, and the fall from June 2 to September 1 are shown in the following tables:

*Fluctuation of water table at Fresno, Cal., March 17 to June 2, 1904.*

	Mar. 17 to Apr. 3 (17 days)	Apr. 3 to May 5 (32 days)	May 5 to June 2 (28 days)
Well No. 1:			
Total rise	Inches. 12.0	Inches. 11.0	Inches. 4.25
Average daily rise	.705	.343	.152
Well No. 2:			
Total rise	11.0	5.0	5.50
Average daily rise	.647	.156	.196
Well No. 3:			
Total rise	11.50	2.50	7.0
Average daily rise	.676	.078	.25
Well No. 4:			
Total rise	11.75	10.75	.0
Average daily rise	.691	.385	.00
Well No. 5:			
Total rise	12.0	9.50	1.50
Average daily rise	.705	.297	.037
Well No. 6:			
Total rise	34.50	12.75	a 1.50
Average daily rise	2.029	.398	a .037
Well No. 7:			
Total rise	6.50	12.50	6.50
Average daily rise	.382	.291	.233
Average daily rise	.832	.271	.113
30 per cent average daily rise to be removed by drainage	.249	.081	.034

a Fall.

*Fluctuation of water table at Fresno, Cal., from June 2 to September 1, 1904.*

	June 2 to July 7 (35 days)	July 7 to Aug. 4 (28 days)	Aug. 4 to Sept. 1 (28 days)
Well No. 1:			
Total fall	Inches. 1.75	Inches. 8.50	Inches. 13.0
Average daily fall	.039	.305	.50
Well No. 2:			
Total fall	19.50		
Average daily fall	.556		
Well No. 3:			
Total fall	20.50		
Average daily fall	.585		
Well No. 4:			
Total fall	13.75	7.0	
Average daily fall	.393	.25	
Well No. 5:			
Total fall	9.50	7.25	14.75
Average daily fall	.271	.259	.527
Well No. 6:			
Total fall	.75	4.75	9.75
Average daily fall	.022	.17	.357
Well No. 7:			
Total fall	5.0	.75	11.75
Average daily fall	.143	.026	.457
Average daily fall	.233	.144	.267

Water was turned into irrigation canals the first week in January and turned out the second week in September.

The average daily rise, in inches, during the part of March in which water appeared in the wells was 0.832; in April, 0.271, and in May, 0.113. Deducting 25 per cent for the capillary water required leaves 30 per cent to be removed by drainage. This amounts to 0.249 inch in depth daily in March, 0.081 inch in April, and 0.034 in May. It should be observed in this connection that during a part of the time a portion of this water may be used to supply needed moisture to the soil above the water plane, the amount depending greatly upon the kind of crops grown on the land and the frequency of its irrigation. This is necessarily an indeterminate amount and may in some cases be nothing.

The plans submitted in 1903 for the main drainage of this area provided for the removal of 0.098 inch in depth each day, with drains located to hold the plane of saturation at a depth of 5 feet from the surface. After the water first appears in the wells in March the rise is quite rapid, the first measurement being made when the water is below the 5-foot horizon; hence the rate of rise for the first period is greater than will be necessary to offset by drainage.

The data furnished by the records of the two years indicate that the capacity of the drains proposed will be sufficient, though not greater than it will be wise to provide. The facts bearing upon the solution of this drainage problem are herein pretty clearly presented. It should be observed that though water was turned into the canals during the first week in January, water did not appear in many of the wells until March 17, but that the rise was rapid during the remainder of the month. The rate was approximately the same in all of the wells, indicating that the rise was not materially interfered with by local differences in the soil. This water represents waste from canals and from early irrigation in sufficient quantity to raise the level of the soil water to within 24 inches of the surface before it began to decline. The soil is sufficiently permeable to water to respond readily to the action of drains should they be provided, with the exception of areas where hardpan is found. This material affects the distribution of irrigation water locally, but not the general water level as it rises during the irrigation season. Drainage will not be required after June 10 of each season, as the water then begins to decline and reaches the bottom of the 8-foot wells in September. In view of these conditions it may be urged that drainage by pumping is especially practicable.

A single well into which drains are discharged may be pumped and local drainage provided. Investigations thus far lead to the opinion that a well or drainage sump may be employed in this way with greater effect than was at first supposed, so that a few land-owners may, in the absence of more comprehensive plans, unite and in



this way effect such drainage as they need. It could not be expected, however, to restrict the benefit of such work to the land it is intended to serve, because of the readiness with which water passes through the soil of adjoining lands. This plan is worthy of careful consideration and experiment.

Soil-water records kept at Sunnyside, Wash., for a period of eighteen months show a condition quite different from that in the Fresno district, California. At the latter place the surface is a plane with uniform slope of 4 to 5 feet per mile, with no ditches for drainage. As may be learned from figures 78 and 79, the water table rises to the 5-foot horizon during the first part of the irrigating season, reaches its maximum height in June, then declines and falls below the 5-foot depth limit in September. The surface of the Sunnyside district is more broken, the larger unbroken areas having a slope of 20 to 50 feet per mile, with a final drainage relief in a valley ditch. The profiles (figs. 80 and 81) represent the fluctuations of the water table at two locations. Well No. 19 is situated near the lower border of a tract of irrigated land extending fully 1 mile back, the seepage and drainage of which gravitate toward the well whose record is represented. Well No. 3 is on the opposite side of the same valley and has back of it only two fields from which seepage and drainage are derived.

In the first soil water reaches its lowest level in August of the first season, from which time it rises until November 1 at an average daily rate of 0.43 inch, then maintains this level until April 16, when it begins to descend, reaching its lowest level again in July and August. During the second season the daily rise is 0.312 inch, and reaches its maximum November 1, as in the first season.

In the second well the same general movement takes place, but the area of land behind it being much smaller, the water level does not retain any one position as persistently as it does in well No. 19, where the supply area behind it is larger. The rise begins in May, reaches its maximum September 1, which it retains three months before it begins to decline. The average maximum rate of rise during the first season was 0.261 inch per day and during the second season 0.348 inch.

The records of other wells indicate similar fluctuations, but with modifications which evidently are the result of the slope of the land and of local irrigation.

The period of high soil water occurs during fall and winter and continues three to five months, while at Fresno it is in midsummer and maintains its maximum height only one month. It appears from these records—

(1) That the highest and longest continued water level of the soil is maintained near the foot of the more extended and uniform surface slope.

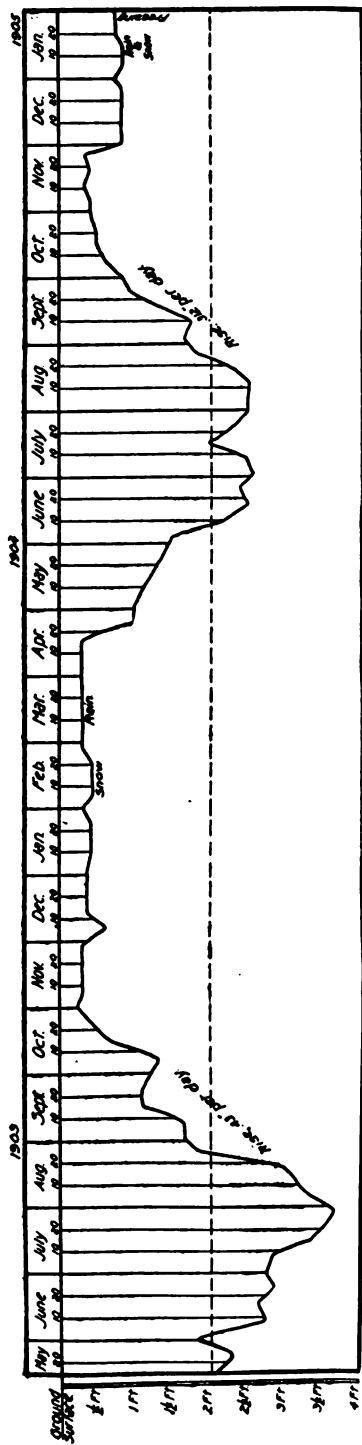

Fig. 80.—Record of well No. 19, Sunnyside, Wash.

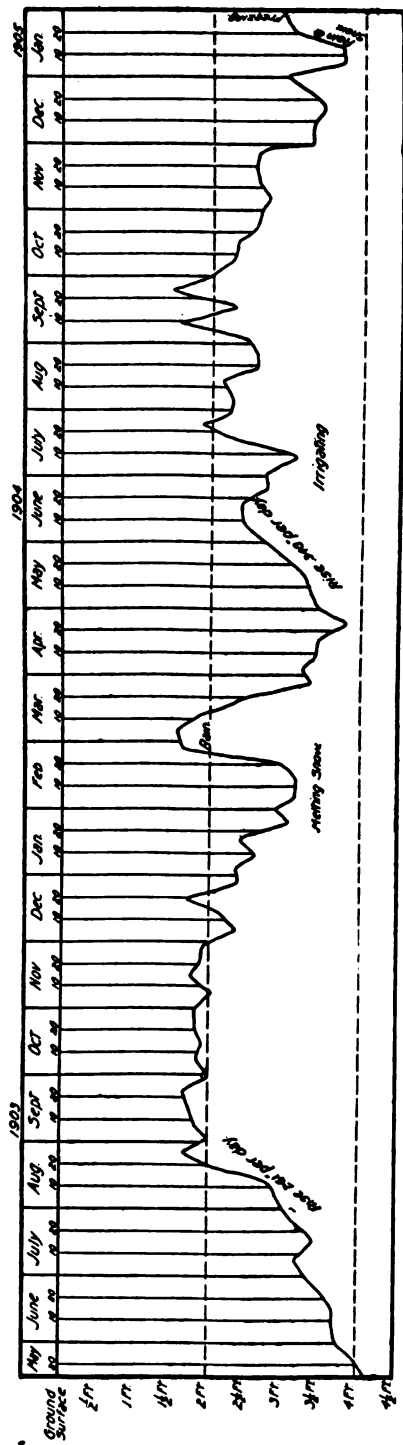

Fig. 81.—Record of well No. 3, Sunnyside, Wash.

(2) That the daily rate of rise at any point depends upon the degree of surface slope, the openness of the soil, and amount of water applied to the land lying above it.

(3) That the daily rise of the water plane varies from 0.26 to 0.43 inch and that the daily drainage that should be provided is a depth of 0.08 to 0.13 inch over the land to be drained.

(4) That the drainage required for each 40 acres which show injury by saturation is 0.1 to 0.2 cubic foot per second, requiring a 6-inch pipe drain or its equivalent for the greater amount.

These deductions are made from averages obtained from the measurements of rise of soil water. A minute study of these changes, as well as experience in dealing with soil water as affected by irrigation and rainfall, suggests that, while drains of the capacity indicated may be sufficient for the work, local conditions may necessitate a doubling of the drainage capacity provided, which may be accomplished either by enlarging drains or increasing the number of drains of the smaller size. The minimum size for underdrains to be used in loose soils under irrigation should be 28 to 36 square inches in section where they are laid across the slope upon a minimum grade of 0.2 per cent.

#### DRAINAGE IN UTAH.

There is scarcely an irrigated valley in the State of Utah which has been cultivated for a term of years in which some of the best land has not become too wet for cultivation and abandoned or from which only uncertain crops of inferior value are now obtained.

Among the several counties examined in Utah none affords a better example of the conditions which produce boggy lands, the resulting serious losses suffered by their owners, and the difficulties in the way of their reclamation than are found in Washington County, near St. George. The tract, which was examined in June, 1904, was at one time a barren lake bed, but when it was irrigated by an extension of the St. George and Washington canal it became the most productive land in the Rio Virgin Valley. The map of this tract (fig. 82) shows that the canal passes on three sides of it. The water applied flows from the boundary toward the interior lower part of the tract, resulting in a concentration of waste water in the lower levels to such an extent that the ground is filled with water and the surface so highly charged with alkali that much of it is useless. The surface slopes about 36 feet per mile. The soil is deep red in color and without apparent stratification, a mass of material washed in from the surrounding hills. A drainage ditch has been opened, into which the side ditches receiving the waste of irrigation discharge.

All attempts thus far made to drain this tract have proved unsuccessful. The central drainage ditch, 3 feet and in some places 4 feet

deep, fails to drain the land quite near it. Water flows from the ditches, yet the soil contiguous to them is wet. Alkali in injurious quantities is found on the surface where there is no water. A rim of productive land borders the canal, but much of the interior is abandoned.

The soil possesses one characteristic quite common to irrigated lands which has much to do with its facility of drainage. It is not disposed in horizontal layers or strata, as is the case with most of the soils in

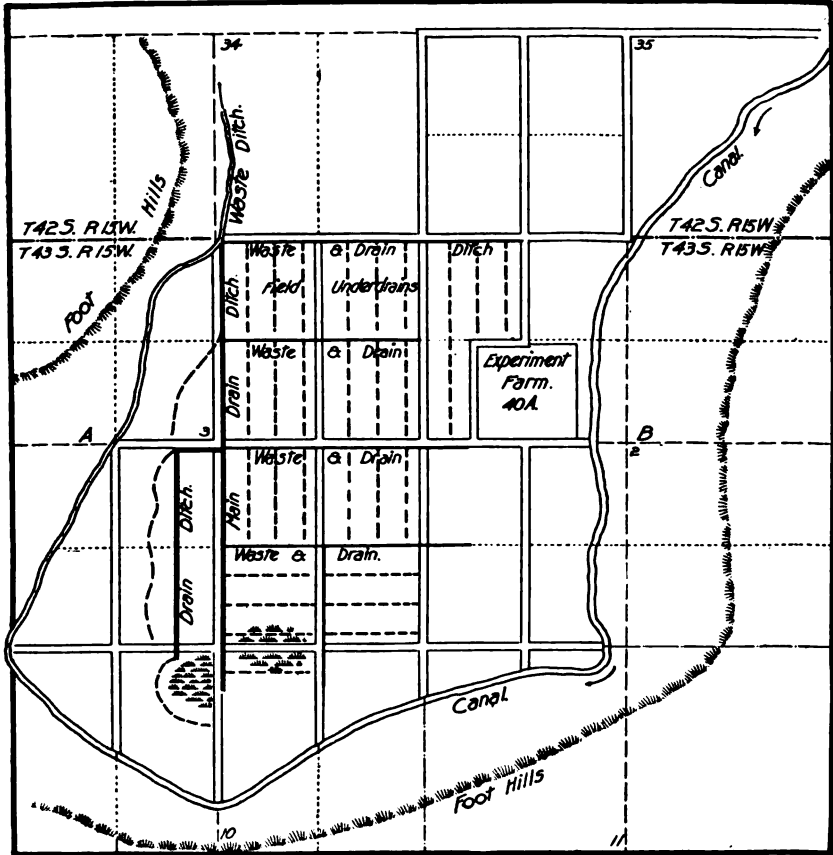

FIG. 82.—Map of lower field, St. George, Utah.

the humid areas, but is a heterogeneous mass, porous, but not stratified. While it permits water to move among its particles, its structure does not materially aid the passage of water laterally, as is the case in a stratified soil. For this reason surplus water goes downward until it fills the permeable soil below, after which it flows to the lower levels and then rises by reason of the head furnished by water occupying higher elevations. This accounts in part for the presence of water near drainage ditches. They receive the excess of water after

the soil has been filled, but do not relieve the soil of its water of saturation. This condition is especially noticeable when land has as much slope as is found in this tract. In the process of irrigation water is applied to the higher land first; this fills the lower levels with a supply greater than can pass through the soil, so that a part is forced to the surface at various points along the downward slope.

The plan of drainage outlined on the map (fig. 82) is but a more complete development of one upon which work has already begun. The main ditch, upon which considerable work has been done, is necessary to receive waste and drainage water and is located in the proper place. It is now narrow, with nearly vertical sides, which are constantly caving and obstructing the ditch. It should be made wider at the top and the excavated earth moved several feet away from the bank, so that the ditch can be easily maintained at the desired depth. The drainage of the land should be accomplished by field drains constructed across the greatest slope, as indicated on the map, and discharged into the waste ditches, which should be enlarged and deepened. Each of the field drains will intercept a portion of the soil water coming down from the upper levels or from below the level of the drains, as the case may be, and conduct it to the outlet or waste ditch, which in turn will discharge into the main passing through the lowest part of the tract. The lateral or field drains will lie at right angles to the greatest surface slope and in position to intercept soil water before it passes to the lower levels of the field.

Lumber is the best material for drains in this section, if for no other reason than that it is the only material which is not prohibited on account of its cost. In many respects box drains are not only the most practical but will prove the most efficient drains that can be used. Boxes made of boards 1½ inches thick, with three sides solid, the fourth side being open, with crosspieces to hold the two adjacent sides in position, are serviceable drains. The box, which is made in sections of convenient length, is placed in the trench, which has been dug to grade, with the open side down, and the sections then joined closely together. The adaptability of such drains to land of this character consists in their being in sections sufficiently long to be self-supporting in soft, wet ground and also in their being closed on top so securely that soft and fluidlike soil can not enter them. All water will enter the drains from the bottom and flow along the earth floors until discharged into the outlet. Field drains 80 rods long may be made with sides of boards 6 inches wide and a top board 8 inches wide, having cross-ties on the bottom 4 feet apart. A drain with these dimensions has a sectional area of 33 square inches.

No lands in Utah are more seriously affected by seepage and alkali than those in the vicinity of Huntington, in Emery County. Many acres formerly productive are entirely destitute of vegetation. Some

lots in the village formerly occupied by buildings have been abandoned and are now boggy and covered with alkali. Seepage is making rapid inroads upon productive areas, and the people realize that they must reclaim their lands or soon abandon them.

The surface is undulating and cut into small valleys, which will facilitate the action of any drainage ditches. The soil is underlain by black shale or slate in many places, by the disintegration of which the soil has been largely formed and which also serves to prevent the even distribution of the soil water, concentrating it at various points, where it speedily produces saturation and later alkali. It is noticed that the action of water disintegrates the shale in places, thereby producing changes in the subsoil which continually modify the drainage condition. Farmers have made no attempts to open main drainage channels or to relieve the land of surplus water in any effective way; on the contrary, additional water has been used on those lands which show alkali for the purpose of washing it out and encouraging the growth of certain plants which flourish in wet alkali soils, to give the land a better appearance by reason of the green vegetation, which also affords some pasturage.

Some surveys were made in the vicinity of Huntington and a system of drainage outlined and recommended, preliminary to detailed plans which could be executed later. Some soil-water wells were put in and observations of the fluctuations of the water have been made weekly during the season for the purpose of determining more fully the difficulties that must be overcome in draining these lands. The results of these observations indicate that the land in that locality must be treated according to the peculiar conditions which develop in the several slopes and that examination of individual tracts will be required preparatory to adopting plans for adequate drainage. However, a few main intercepting drainage ditches should be constructed and will be of general service. These conditions were pointed out and suggestions made with a view to impressing upon landowners the necessity of immediate steps being taken toward constructing the main ditches preliminary to more complete drainage of farm lands and village lots.

In Cache County the land in the vicinity of Logan rises from the streams in a series of benches, the lower lands being underlain with clay and the higher with gravel. Only the higher benches have escaped injury from the excessive use of water. The flow, in many instances, is apparently through crevices or channels in the soil, but there appears to be no hardpan or shale formation such as is found in the locality in Emery County previously described. The water flows to the lower levels and makes its appearance at the surface in July and August, indicating that there is a comparatively free flow through the soil when the land above becomes saturated. No alkali

appears, but the land is made boggy to such an extent that frequently only water grasses thrive.

A large number of soil-water wells have been put down near Hyde Park and weekly measurements made to determine the water conditions peculiar to the soils of both bench and bottom lands. Co-operative arrangements have been made with several farmers under which this Office and the Utah Experiment Station furnish the drain tile and the farmers the labor for making an experiment in draining some land which has become seeped from the underflow of gravel land above and unfit for the production of the best crops. Drains were constructed in September, 1904, so that while the observations so far are interesting they are only preliminary and the results, when obtained, will be made the subject of a later report.

### **CLEANING DREDGED DRAINAGE DITCHES.**

In localities where the construction of dredged drainage ditches is contemplated, inquiry is often made regarding the permanency of these channels and the frequency of repairs that it may be necessary to make upon them. Ditches of this class were first constructed for the drainage of level areas in Illinois and Indiana about twenty-five years ago. The adaptation of the steam shovel and river dredge to the work of excavating ditches through level lands gave a marked impetus to the reclamation and improvement of farm lands in those States. Usually but little care has been bestowed on the ditches after their construction, and in many instances they have been neglected to such an extent that grass, willows, and other vegetation have grown up in the channels and silt has been deposited, thereby impairing their efficiency. The difficulties met in cleaning the smaller dredged ditches—those 6 to 8 feet wide on the bottom—are the small amount of excavation required on each linear foot of ditch, the mucky and sticky nature of the material, and the height to which it must be raised. Under such conditions the price of excavation will be high. The first work of this kind noted in Illinois is in Iroquois County, a description of which will serve to indicate the character of the work already beginning elsewhere.

The ditches to which reference is made were excavated with small drag dredges seventeen years ago. They were 6 to 8 feet wide on the bottom, 6 to 9 feet deep, and had side slopes of 1 to 1. The grades upon which they were dug were 3 to 4 feet per mile. The side slopes have remained approximately as made, but silt and wash have accumulated until the bottoms have been raised 2 feet or more. The entire district of 17,000 acres for which the ditches give drainage outlets is tile-drained, the efficiency of the several systems depending upon the maintenance of the dredged ditches at their original depths.

The conditions found here favor the growth of luxuriant vegetation in many sections of the ditches. The area served by the drainage system is in the belt of artesian wells, so that in places there is a constant supply of waste water flowing into the ditches, furnishing the best possible condition for the growth of flags, water grasses, and willows. Failure to remove these growths annually has permitted trees of considerable size to grow in the ditches. In localities where there is no artesian water it is not uncommon to find the ditches dry during a part of the summer, in which condition they may be cheaply cleared of growing vegetation. Some parts of the ditches are obstructed by fine earth which has been carried by winds from adjoining plowed fields during the late fall or early spring and intercepted by the ditches.

A contract for cleaning 16 miles of these ditches was let in 1903, at 22½ cents per cubic yard. The bottoms were to be finished 6 feet wide and the side slopes of the excavated portions made 1 to 1, but the side slopes above the plane of excavation were not to be changed. The excavation ran about 1 cubic yard to the linear foot of ditch. The work was done with drag dredges, but they were operated downstream, contrary to the usual manner of working these machines, in order that water for the boilers might be constantly obtained. There were two boats on the work, each with 8 miles of ditch to complete, and the work accomplished by each was 300 to 400 feet of ditch in twelve hours. The outfits had three small houses on wagons which moved from place to place for the accommodation of the men. Four men on a boat and one man and team to haul coal constituted a shift. With the exception of a few places all the ditches pass through firm earth and are finished upon good clay bottoms.

#### **CONSTRUCTION AND MAINTENANCE OF LARGE DITCHES THROUGH SANDY LANDS.**

In digging lateral ditches in the Cypress drainage district, near Shawneetown, Ill., a fine river sand caused some trouble. The specified size of these ditches was 6-foot bottom, with 1 to 1 slope, and depth ranging from 4.5 to 10 feet. The excavating was done with a floating dredge. Trouble occurred in cutting across small ridges where sand was encountered 2 feet below the surface. The motion of the dredge kept the water agitated to such an extent that a great deal of fine sand was taken up by the water and held in suspension. It also caused the sandy material in the banks to cave in back of the machine. After the dredge had passed a sufficient distance for the water to become quiet the suspended matter was deposited in sufficient quantities to raise the bottom of the ditch 0.3 to 0.6 foot above the line to which it had been excavated. To obviate this difficulty



the ditch was excavated wider and deeper through those places than the specifications called for. It is the opinion of those who have had experience in this work that ditches excavated through sandy land will require cleaning about two years after construction.

In southeastern Missouri a great deal of dredge work has been done during the past few years in material of a more or less sandy nature. The country is underlaid by a sand stratum 5 to 12 feet below the surface, and it is customary to excavate the ditches so that the bottom will be 2 to 3 feet below the top of the sand, as better underdrainage is secured when this stratum is opened. The specified slopes of the ditches are 1 to 1. The contractors dig the ditches 1 foot deeper and 1 to 2 feet wider on the bottom than specified, to avoid going over the work again in case of any filling in of the ditch after the dredge has passed. Usually very little material falls into the ditch during construction. Occasionally in cutting through a sand ridge it caves to such an extent that the dredge must pass over it the second if not the third time before the ditch will maintain its specified dimensions. However, these stretches are short and infrequent and are not regarded by the contractors as serious difficulties. The greatest trouble in these ditches is due to the caving of the banks during the spring thaws. Experience so far indicates that ditches with 1.5-foot fall per mile will keep reasonably clean, as the caved material is carried away in suspension by the water. Where the fall is less than 1.5 feet per mile the ditches fill rapidly, and it has been found necessary to clean them in a year after construction. It is thought that thereafter once every three years will be sufficient.

It should be noted in this connection that the ditches in southeastern Missouri have no free outlet at grade, but are extended southward through the valley until their waters are discharged by overflow on the lower-lying lands or into shallow and obstructed channels. Under such conditions a much larger percentage of sediment will be deposited in the lower reaches of channels than if they were free to discharge into an adequate outlet stream.

#### **PLANS FOR THE DRAINAGE OF THE BOTTOM LANDS OF THE MISSOURI RIVER IN SOUTH DAKOTA.**

Between the bluffs of Clay Creek on the east and the Missouri River and James River on the south and west is a large and fertile valley comprising 71,000 acres. The Chicago, Milwaukee and St. Paul Railroad passes through the central portion of this tract. The towns of Meckling and Grayville, on this road, are conveniently situated for the commercial accommodation of this territory. Large portions of it have been cultivated and are always found productive in favorable seasons. No complaint has been entered against the

land except that it is often too wet for profitable cultivation, it often being difficult to secure the crop of wild grass because of the wet condition of the soil.

Not only are the owners of the land vitally interested in its improvement, but the towns of the valley depend largely upon the land for their business. The loss of production for either of the last two years amounts to a sum which if applied to drainage would easily pay for all of the main ditches required. It is a matter of public concern that land of this character, with ready market and transportation facilities, be drained. Roads may then be established, farm improvements made, and the land cultivated in the most approved manner.

The questions arise: How may this result be brought about? What are the preliminary steps to be taken toward its accomplishment? What will be its cost? What laws, if any, should be enacted to enable owners to combine and drain large areas and distribute the cost equitably over the land improved?

For the purpose of obtaining answers to these questions and getting at the matter in a comprehensive way, some of the citizens petitioned the Office of Experiment Stations of the United States Department of Agriculture for such assistance as the Department might be able to give. The matter was referred to the irrigation and drainage investigations, and the report herewith submitted gives the result of such investigations. A preliminary plan and estimate were made and suggestions were offered relative to State legislation upon drainage.

#### SURVEY.

In the absence of knowledge concerning levels, slopes, nature of streams, and natural depressions of the area to be drained, it was decided to make a level survey from which a drainage plan could be developed. This was done in August, 1904, by John T. Stewart, in charge of field surveys. A description of the manner in which this survey was made may be of service to engineers and others interested in similar projects.

The first step was to collect such information concerning the land in question as could be obtained from the county records. Convenient plats for field use were made upon Land Office township blanks on a scale of 2 inches to the mile. Upon these were traced all Land Office data and such roads, ditches, and sloughs as were shown on the county maps. A day was then spent in making a general reconnoissance by driving over the area, in order to become somewhat familiar with its general topography. In this reconnoissance it was seen that the section lines could be easily followed, as where they

were not marked by highways there were fences or turning rows located on them, and nearly all the one-quarter and one-sixteenth section lines could be approximately located on the ground by fence or field lines.

From the reconnoissance and the field plats it was found that field measurements could be obviated by using land lines for locations, and all additional data necessary could be obtained by running levels. The plan decided on and carried out consisted in running levels along parallel north-and-south section lines 2 miles apart, extending from the ridge which marks the high-water bank of the Missouri River to the foot of the bluff. A permanent bench mark of the Missouri River Commission survey furnished the datum for the levels. Levels were recorded at each one-quarter mile along the lines surveyed, the instrument being set midway between the one-quarter mile turning points. Turning points were taken on short wooden pegs driven to the natural surface of the ground. A target rod was used and read by both levelman and rodman.

A light two-horse rig, with driver, was kept on the line and used to convey the rodman from one turning point to another. As the rodman moved one-quarter mile at a time and there was usually a good road, there was a considerable saving of time in the use of the rig, which was also used for conveying the party to and from work and for carrying water, lunch, and such survey stakes as were needed.

From 5 to 10 miles of level lines were run per day. The growth of high grass and weeds often retarded the work. The number of side shots which were necessary to secure desired data also cut down the day's run. Side lines were also run to the lowest points in sloughs or depressions 1 mile each side of the main line. Where there was water in the sloughs the elevation of the water surface was taken and the depth found by sounding from a boat or wading. The level of the surface of the water of both Missouri and James rivers was also obtained. The high-water marks were obtained from points located by residents, and the low-water marks were determined from the plats of the Missouri River Commission. Bench marks were established at nearly all section corners and were made by driving 30-penny spikes into corner fence posts or telephone poles at the surface of the ground, a blaze being made about 4 feet above the spike and the elevation marked upon it. Each night the elevations were recorded in their proper locations upon the field plats.

After the completion of the level work, the line between the cultivated and wet land was sketched upon the field maps by personal inspection. After the data had all been collected and platted the interior watershed boundaries and lines of proposed ditches were located on the field maps. A corrected map on a scale of 1 mile to

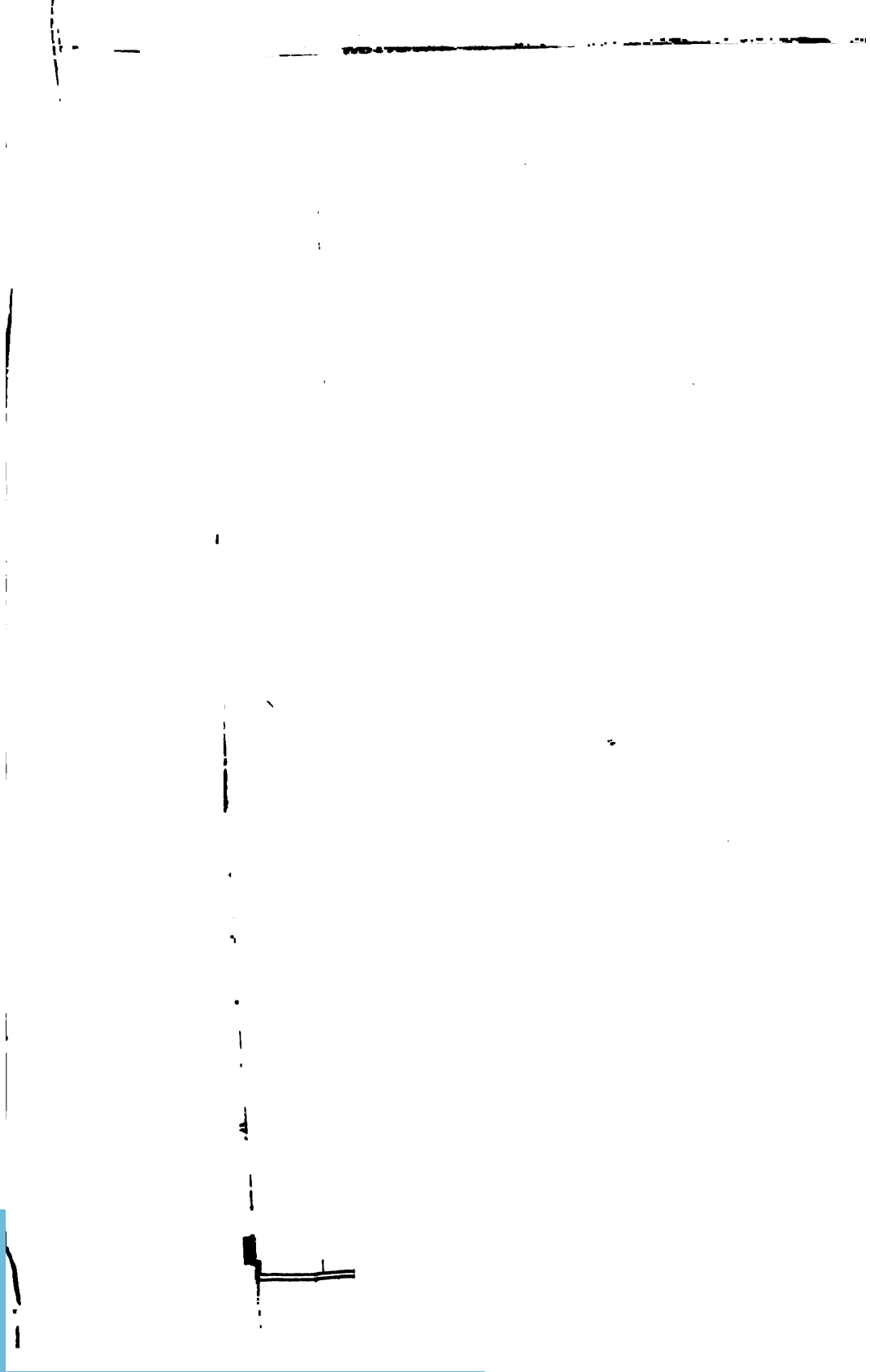



1 inch was afterwards made up from the field maps and is here shown. (Pl. IX.) The cost of this survey was as follows:

*Cost of running 82 miles of levels and making field plans and estimates.*

Engineer, 14.5 days' leveling, at \$6 per day-----	\$87. 00
Engineer, 5.5 days' special field examinations, at \$6 per day -	33. 00
Rodman, 14.5 days, at \$1.75 per day-----	25. 37
Livery hire, team and driver, 20 days, at \$3 per day-----	60. 00
Railway fare-----	2. 25
	<hr/>
Total cost of survey-----	207. 62
	<hr/>
Engineer, 12 days' office work, at \$6 per day-----	72. 00
Drafting supplies-----	1. 50
	<hr/>
Total cost of plans-----	73. 50
	<hr/>
Total cost of survey and plans-----	281. 12

Regarding this preliminary survey, it should be said that only sufficient work was done to furnish the information required for developing a general plan, yet all levels are accurate and are connected with and checked upon Government river survey bench marks. A list and description of bench marks, which were fixed at each section corner of the surveyed lines, accompany the report and map which were filed with the auditor of Clay County, the expense of which is not included in the above memorandum. The survey was inexpensive, yet sufficiently full for forming a comprehensive plan for the drainage of 70,000 acres of land, and established a sufficient number of points from which future surveys for detail and construction work can be made whenever required.

#### TOPOGRAPHY.

A profile or section of three of the lines running from the river to the bluff shows that the surface near Clay Creek is, in every case, 2 feet or more lower than the surface of the land one-half mile distant from the Missouri River banks; that the banks of the river are, with a few exceptions, higher than any land found in crossing the valley directly toward the bluff, and that the valley has a slope of 8 to 12 inches per mile from the river directly toward the bluff (fig. 83). It is also observed that the general slope down the center line of the valley in a southeasterly direction toward Vermilion River is about 1 foot per mile.

#### SOURCES OF WATER.

The water to be considered in draining the valley comes from three sources: (1) Clay Creek and its tributaries; (2) overflow from James River between Mission Hill and its junction with the Missouri; and (3) direct rainfall upon the surface of the tract. Water from all of these sources contributes at times to the injury of the land, for which



FIG. 88.—Profiles across Missouri River Valley, from river to bluff.

no adequate remedy has been provided. Clay Creek brings the drainage from a watershed of 60,000 acres, and Turkey Creek that from 39,000 acres, all near the head of the valley and 17 miles from any river outlet. The entire area to be drained through the outlet of Clay Creek channel is 160,000 acres, about 39,000 acres of this being valley land and the remainder hill land.

#### PLAN OF DRAINAGE.

The plan outlined on the map (Pl. IX) contains the following features:

(1) A large channel on the line of Clay Creek ditch, extending from the bridge about 2 miles above the town of Vermilion upstream to the north line of sec. 15, T. 94, R. 54, a distance of 17 miles.

(2) What may be called the Meckling ditch, to take the general course of the old ditch bearing that name, as shown upon the map, the same to discharge into Clay Creek ditch and form a part of the Clay Creek ditch system. Its total length, as mapped, will be 10.75 miles.

(3) The Gayville ditch, which provides the main drainage for the land south of the railroad. Its source, or head, is east of Mission Hill, in Yankton County. It passes through and drains a chain of sloughs and discharges into Vermilion River near the railroad bridge west of the town, having a total length of 20.5 miles.

(4) Two levees 5 feet high along James River, one at Mission Hill and the other near the mouth of that stream, to prevent the ordinary high-water floods from breaking over.

The main ditches named divide the valley into areas of such size that drainage by laterals can be accomplished without great difficulty. Clay Creek ditch may be used for draining 30,000 acres of the valley, Meckling ditch for 8,700 acres, and Gayville ditch for 32,600 acres. The tract north of the Milwaukee Railroad may be drained independently of that on the south side, and vice versa, though by reason of the level character of the land one portion can not be drained without incidentally benefiting the other.

#### SIZE OF DITCHES.

The Clay Creek ditch watershed has some peculiarities which should be considered in determining the size of its channels. The larger portion of the water to be carried is received at or near the upper end. The run-off of 39,000 acres from Turkey Creek and 60,000 acres from the head of Clay Creek is delivered to the ditch along the upper 2.5 miles of its length, coming to it through natural channels. The ditch also receives the drainage from about 39,000 acres of valley land, brought to it by lateral ditches, as well as from 22,000 acres of hill land below Turkey Creek.



Starting at the bridge 1 mile above the junction of Clay Creek with Vermilion River as an outlet point, the ditch will have a grade of 1 foot per mile for 11 miles and of 1.5 to 2 feet per mile for the remaining distance of 6 miles. The width of the bottom of the ditch for the lower 11 miles will be 50 feet and its depth 6 to 9 feet. From a point where the grade increases to 2 feet per mile to Turkey Creek, a distance of 3.5 miles, the bottom width will be 35 feet. From that point to the end, a distance of 2.5 miles, the bottom width will be 30 feet. This ditch is designed to carry one-fourth of an inch of water each twenty-four hours from the entire head end of the watershed, which extends from the upper end of the ditch northward about 40 miles.

The Gayville ditch will drain 32,000 acres. It will have a bottom width of 16 feet at the outlet, which is at Vermilion River, and will diminish in size as the upper end is approached. It will be 6 to 13 feet deep, except in the deep sloughs, and 20.5 miles long.

#### ESTIMATE OF COST.

The estimates herein submitted indicate the approximate cost of executing the main drains described. The valley may be taken up in two separate systems—the upper and the lower—or, as the map shows, the Clay Creek ditch and the Gayville ditch, with their several tributaries.

#### *Clay Creek system.*

Clay Creek ditch excavation .....	\$112, 507
Turkey Creek ditch excavation.....	740
Meckling ditch excavation .....	20, 880
Damage claims, Clay Creek.....	10, 000
Damage claims, Meckling ditch.....	3, 000
Organization and contingent expenses, 5 per cent.....	7, 356

Total cost .....

154, 483

(Number of acres benefited, 38,700; average cost per acre, \$3.99.)

Lateral ditches for more complete drainage of lands and roads:

Main system, laterals discharging into Clay Creek ditch, 33 miles .....	\$29, 100
Meckling ditch system, 5.75 miles.....	4, 728
Contingent expenses, 10 per cent.....	3, 383

Total cost .....

37, 211

(Average cost per acre, \$0.96.)

*Gayville ditch system.*

Gayville ditch excavation .....	\$54,384
Levee on James River, 3 miles.....	4,120
Damages .....	6,000
Contingent expenses, 7 per cent.....	4,515
<b>Total cost .....</b>	<b>69,019</b>
(Number of acres benefited, 25,000; average cost per acre, \$2.76.)	
Laterals for Gayville ditch system, 31 miles.....	\$25,614
Contingent expenses, 10 per cent.....	2,561
<b>Total cost .....</b>	<b>28,175</b>
(Average cost per acre, \$1.13.)	

The estimates on lateral systems are here given to indicate the probable final expense of such drains as will be required for both farm and road improvement. They are shown upon the map for the purpose of indicating the general plan, but should be constructed in connection with the improvement of the road system.

These estimates are of a preliminary nature and indicate only the general and average elements of expense which may be encountered. Damages to property and right of way for ditches may be placed at high figures by some boards. Legal expenses are an exceedingly variable feature in ditch cases. It should be understood in all cases that the property affected by the improvement must pay the cost of construction of the main ditches. Any unnecessary increase of expense merely reacts upon those who, under the laws relating to drainage, must pay the bills. These estimates may be regarded as sufficiently close to determine the practicability of the project herein proposed for the drainage of the valley.

**EFFECT OF RIVER BACKWATER.**

The two main ditches will discharge into Vermilion River. The low watermark recorded by the river survey at the mouth of Vermilion River is 24.6 feet. As near as can be determined, the high watermark is 20 feet above this. According to these figures it may be expected that the high-water stage of Vermilion River will affect the flow of the ditches for a distance of 10 miles upstream, but that it will not seriously affect the drainage of adjoining land for more than 4 miles back unless the extreme high stage should be long continued.

**COOPERATION OF TWO COUNTIES REQUIRED.**

The plans outlined involve the improvement of land in two counties, Clay and Yankton. The portion lying in Yankton County, if drained at all, must be drained through Clay County to Vermilion River, as indicated in the described plan. Cooperation of the two

counties in this work is the only proper way to handle the proposition.

It will be noted from the estimates given that while the aggregate expense is large the amount per acre, when distributed over the whole area, is small. The main outlets for drainage should be constructed at the expense of all the land affected, and thus become common outlets.

#### **DRAINAGE LAWS.**

A project of this magnitude can not be worked out without the assistance of a drainage law. South Dakota has a law intended to meet the requirements of citizens who wish to drain their farm lands, but in the absence of an affirmation by the court its constitutionality is questioned. In any event some amendments will be required to make the present law applicable to projects requiring combined drainage. The statute as it now stands makes no provision for the issue of drainage bonds secured by liens upon the lands assessed for the improvements. It is better economy for landowners to pay interest on bonds for a time, while their land is being reclaimed and brought into a more productive condition, than to pay the entire amount in cash. Money applied in developing farm land will bring much greater interest than is called for by the bonds.

The method of making assessments for benefits and the preparation of assessment rolls is not sufficiently defined in the present law. The liability of the district and county in the construction of highway and field bridges is not provided for. No provision is made for securing right of way for ditches by condemnation proceedings, which may sometimes be necessary in carrying out a project.

It is distinctly stated that all ditches shall be completed from the outlet upstream, a thing that is impracticable in large works. The matter of giving proper legal notices to all landowners through the different stages of work is not sufficiently provided for.

A careful perusal of the later enactments on drainage of other States, when compared with the South Dakota law, will bring to light the fact that the latter is legally and physically deficient in many important respects. A drainage law should form a complete rule of procedure from start to finish. It should be of such a character that it may be followed step by step, with the assurance that when it is so followed the legality of proceedings can not be attacked.

#### **SUGGESTIONS AS TO ORGANIZATION.**

Before any drainage project can be carried out harmoniously a large majority of the landowners should appreciate the necessity of the work and favor it. The law merely permits the county commissioners to prosecute such work under provisions which will secure to

each property owner an equitable division of the cost, and his rights in the works when completed. While under the law one or more owners may legally present a petition, it is desirable to have as many owners as practicable signify their indorsement of the project by signing the petition.

The drainage of the valley under consideration may be taken up in two divisions. Any further division would be unwise. The interior or lateral ditches outlined upon the map may or may not be included in a petition for main ditches. A petition for either of the main drainage plans may be drawn describing the territory to be included and the ditches to be constructed. Such a petition, when accompanied by a sufficient bond and filed with the auditor, brings the matter under the jurisdiction of the county board. The board must then proceed as directed by law. The history of this class of work in other States emphasizes the necessity of having a clear and well-established drainage law in force and of a close adherence to the letter of the same in every essential particular.

### RECLAMATION OF OVERFLOWED LANDS.

The fertile overflowed lands lying along the alluvial streams in Indiana, Illinois, and Iowa attracted the attention of settlers many years ago. As early as 1858, a rudimentary system of protection for these bottom lands was begun (fig. 84), but no well-organized plan of improvement was carried out until 1873. The greater part of these lands, now included in drainage



FIG. 84.—Section of old Iowa River levee, built in 1858.

districts, has been improved since 1890. The difficulties encountered in making this class of improvements have in many instances been greater than landowners expected, so that the results of the work have not uncommonly been disappointing. In order that the experience thus far gained in reclaiming overflowed lands might be collected and made available to those desiring to repair injured works or execute new ones, an investigation of the peculiar conditions upon which the success of such improvements depends was carried on during a part of the year. An examination was made of the lands lying along the Wabash River in Indiana, the Illinois River from Peoria to Kampsville, in Illinois, and the Mississippi River from Albany, Ill., to Louisiana, Mo., and information obtained through interviews with engineers, attorneys, commissioners, landowners, and others who were familiar with this class of work, and by personal inspection and measurement of the structures of different reclamation systems.

**ILLINOIS RIVER.**

The bottoms along the Illinois River vary in width from 1 to 3 miles. The river usually flows nearer to the bluffs on one side of its valley than to those on the other, leaving the bottom lands at any point largely on one side of the river. The stream has been improved for navigation by means of locks and dams, there being three of these structures on this section for the purpose of maintaining a navigable channel throughout the low-water period. On account of these improvements the river does not reach the old low-water stage between Peoria and Kampsville, where the lower dam is located. The gauge readings now used are often based upon a different datum from that employed before the dams were built. At Havana, Ill., the lowest gauge reading since 1890 is 1.7 feet, recorded in September, 1896, and the highest is 19.9 feet, recorded in March, 1904. The latter is the highest flood ever recorded at that place and is notable by reason of the fact that the water remained above the 19-foot mark for ten days. From 1890 to 1898 the high water ranged from 9.9 to 17.8 feet, during two years of which time it failed to reach the 12-foot mark. From 1897 to 1904 it ranged from 13.7 to 19.9 feet, reaching during four of these years the 18-foot mark.

Near the mouth of the river the flood did not rise as high in 1904 as in 1903, due to the stage of water in the Mississippi River. In 1904 the Mississippi was not unusually high, so the flood water of the Illinois had a free discharge, while in 1903 the extreme floods on the Mississippi produced an upstream current in the Illinois which was quite perceptible at Kampsville and its effect was noticed as far up as Beardstown. Consequently the 1903 flood in the lower reaches of the Illinois River was higher than the one of 1904.

During the period covered by the gauge readings the maximum yearly floods have occurred from March to July, that of 1904 occurring the latter part of March, while the next highest, 19.2 feet, recorded on the Havana gauge, occurred late in July, 1902.

The river channel along the bottom lands is skirted by a ridge or bank, which is approximately 12 feet above low water. The surface slopes to 1 to 4 feet below this ridge, so that the lands lie 8 to 12 feet above low water. In places there are old channels and sloughs which are much lower than the surrounding land.

With the exception of an occasional sand ridge these bottom lands have a gray alluvial soil, becoming black when mixed with vegetable matter. They are covered with a dense growth of timber, and in their native condition furnish some pasturage in the late summer and fall months. When cultivated the higher parts yield crops about two years out of three, but the lower parts are flooded so frequently

that their cultivation is unprofitable. All of these bottom lands when sufficiently drained and properly cultivated produce large crops of corn and wheat.

PEKIN-LAMARSH LEVEE AND DRAINAGE DISTRICT.

This district lies across the river from the city of Pekin (fig. 85). It covers an area of 2,500 acres and is protected on all sides by

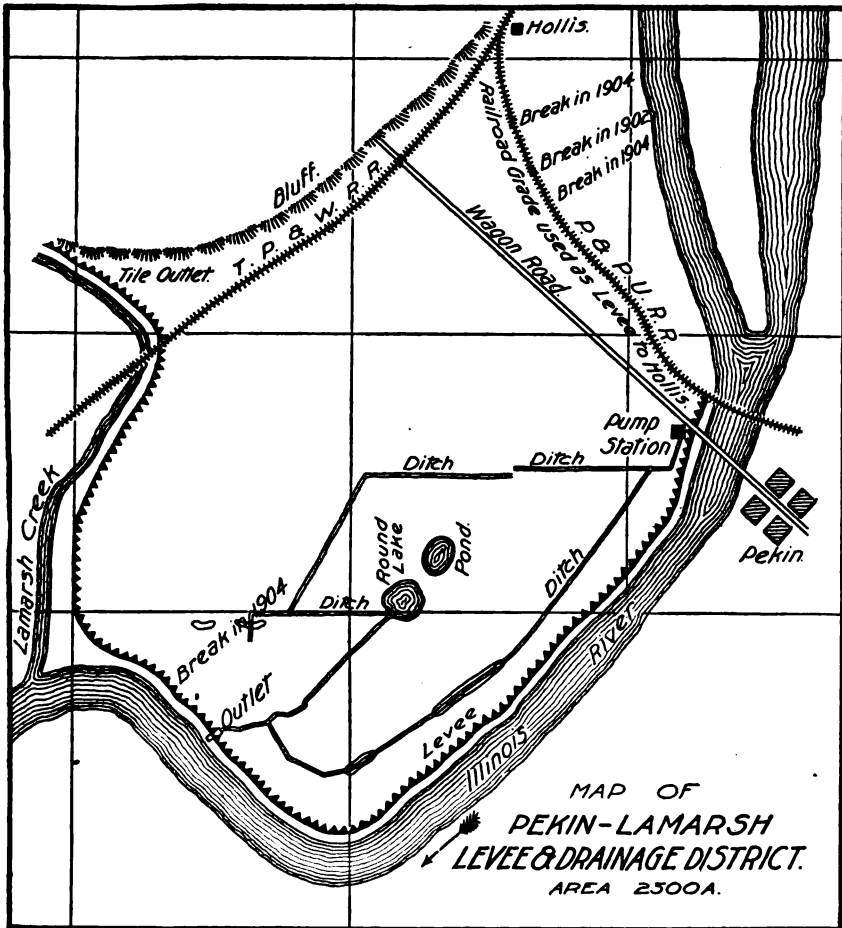

FIG. 85.—Map of Pekin-Lamarsh levee and drainage district.

levees except about 1.5 miles on the northwest, where the bluff forms the back line of the district. An organization was effected in 1889 and work completed in 1890. The Peoria and Pekin Union Railway grade was used for 1.5 miles as a levee on the northwest side from the river to the bluff. Five miles of new levee were constructed along the river bank and up Lamarsh Creek to the bluff. The

work was done with scrapers and the levee finished with a  $1\frac{1}{2}$  to 1 slope on the river or out side, 1 to 1 slope on the district or in side, and 3-foot top. The foundation for the embankment was not prepared in any way, stumps and logs being left, and in some instances trees not being even cut, and the earth for construction was taken from both sides in such a manner as to leave a large continuous ditch on the inside. The railway company filled in a trestle and raised their track in the section used as a levee, burying the old timbers and ties in both cases.

The drainage ditches were constructed with scrapers. A pumping plant was built at the upstream corner of the district and a circular outlet 4 feet in diameter was made at the downstream corner for gravity drainage. The only hill water flowing into the district is that which falls on the slope of the bluff bordering the back line of the district. The present pumping plant consists of a Menge pump with two wheels, having a capacity of 500,000 gallons per hour.

The district was flooded in 1902 from a break in the railway grade caused by the water seeping along the old ties until it carried the levee away. During March, 1904, the water ran over the lower part of the river levee and also over the railway grade, causing a break at each of these places. After the interior became filled with water great damage was done to the levees by wave action on the inside.

It is now acknowledged by those interested in the district that the original cross section of the levee was too small, and that it was faulty construction to build a levee without first preparing the foundation to prevent seepage, to use banks with timbers running transversely across them, and to have borrow pits on the inside; also that it is not economy to buy inferior or secondhand machinery. The drainage system would have been more efficient if the ditches had been made with a dredge and the pumping plant located at the downstream corner of the district.

#### LACEY LEVEE AND DRAINAGE DISTRICT.

This district lies across the river from Havana (fig. 86). It covers an area of 5,180 acres and is protected by 9.5 miles of levees, 7 miles being new levee and 2.5 miles on the north side an old unused railway grade. The bluff forms the back line of the district for a distance of 1 mile.

Work was begun in 1897. The river part of the levee was built on the ridge which marks the river bank in ordinary high water, with a 2 to 1 slope on the outside, 1 to 1 slope on the inside, and 8-foot top (fig. 87). It varies in height from 6 to 13 feet, averaging 8.1 feet. The foundation was prepared by clearing, grubbing, and

thoroughly plowing the entire width of the base of the embankment, one short section having a 4-foot muck ditch under it. The work

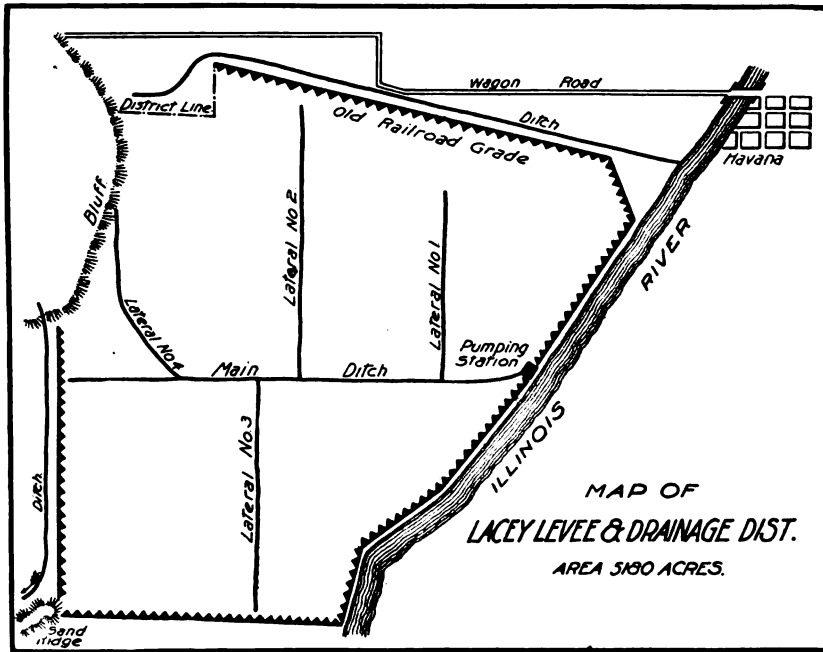

FIG. 86.—Map of Lacey levee and drainage district.

was done with scrapers, the earth being taken from the outside and a 10-foot berm left between the borrow pit and the toe of the slope. The only storm water coming into the district is that which falls on

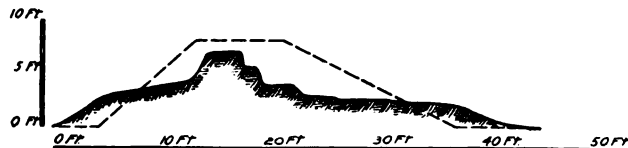
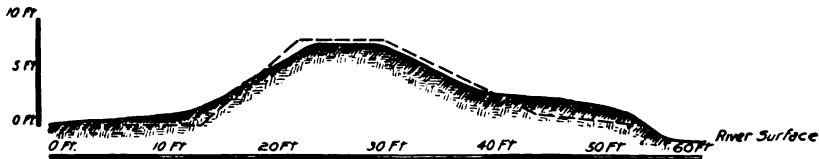

FIG. 87.—Lacey district—change in section of levee since first constructed.

the slope of the bluff. The land is drained by a system of dredge ditches 6 feet deep, but with no fall. The pumping plant is located



near the middle of the river levee and consists of two high-speed engines, two horizontal fire-tube boilers, and two horizontal centrifugal pumps with 20-inch discharge pipes, each pump having a capacity of 750,000 gallons per hour.

This levee failed because it was not built high enough. The top was supposed to be 20 feet above low water. In 1902 the river rose to 19.2 feet and ran over the old railway grade which served as the north levee, flooding the district. In March, 1904, the river rose to 19.9 feet and ran over the low places in the levee. A break in the railway grade was caused by a wave which came from a crevasse in an old levee on Spoon River. After the district was flooded there were high winds, which greatly injured the levee by wave action on both inside and outside where not protected by timber.

#### COAL CREEK LEVEE AND DRAINAGE DISTRICT.

This district, inclosing 7,000 acres lying across the river from Beardstown, was organized in 1897 (fig. 88). The Chicago, Burlington and Quincy Railway grade is used as a levee from the river to the bluff on the east side. Six miles of new levee were built on the south and west sides, it not being necessary to levee against the river water on the north side. With the exception of a short section at the north end of the west levee, work was done with a dipper dredge. The levee was raised to 3 feet above the 1844 high watermark and was built with a 3 to 1 slope on the outside, 2 to 1 slope on the inside, and no specified width of top (fig. 89). The foundation and the land used for the borrow pit were cleared, the stumps dynamited and pulled, and roots taken out to a depth of 3 feet. The earth was all taken from the outside, a 20-foot berm being left between the edge of the borrow pit and the toe of the slope.

The levee as built by the dredge is rough and irregular both on top and on the slopes, caused by the dumping of the dirt 2.5 yards at a time. In finishing, many places were a little low and required only a small amount of material, but a whole dipperful of earth was necessarily dumped, making some places a foot or more higher than necessary. The lowest places were brought to the required height, but the entire surface of the levee is covered with a series of humps of varying heights above the required grade. There was a tendency of the banks to run and slide during construction, due to the soft condition of the material dug out of the water and the successive dropping of the heavy material on the bank. On account of this running of the banks only a part could be put up at a time, so the dredge boat had to pass two or three times before the levee was completed. Because of this sliding a great deal of extra material had to be

moved. When the material finally settled in place the levee became more solid than if it had been put up dry by scrapers.

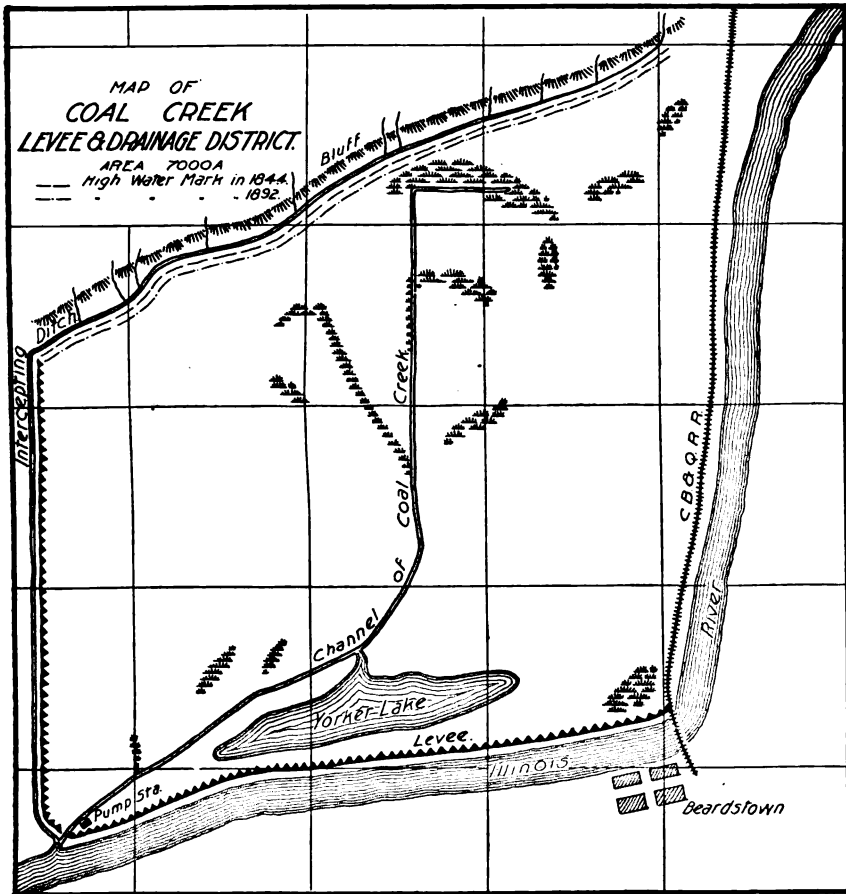

FIG. 88.—Map of Coal Creek levee and drainage district.

Coal Creek runs diagonally across the district from the river to the bluff. This stream was diverted where it comes out of the hills by a ditch which was constructed along the foot of the bluff, intercepting

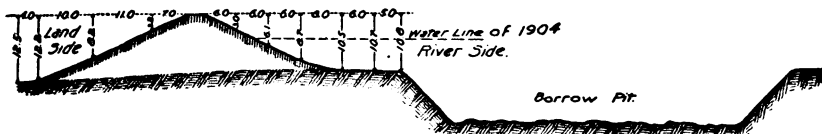

FIG. 89.—Coal Creek district—section of levee constructed with dipper dredge.

in its course several small creeks which come out of the hills and leading their waters around the north end of the west levee and thence to the river. The channel of Coal Creek was dredged out to

form the main ditch of the interior drainage system of the district. The pumping plant is located at the lower end of this channel and consists of one 24-inch and two 15-inch horizontal centrifugal pumps, having a combined capacity of 1,583,000 gallons per hour. Power is furnished by one boiler and a Corliss condensing engine.

The land has not yet been fully reclaimed. It has not been flooded by river water since the completion of the levee, but the water from the hill streams has not been controlled, so that repeated inundations have occurred from that source. Coal Creek and the little streams which flow out of the bluff are so heavily charged with sediment that they fill the channel of the intercepting ditch and cause its water to flow over the waste bank in such quantities that the pumping plant can not remove it. Owing to this difficulty, the interior drainage system has never been completed. During high water there is a great deal of seepage through the railway grade and some through the district levee. It is thought that if a muck ditch had been dug in the foundation of the levee and refilled there would have been no seepage, as the water does not go through the embankment, but through the upper 3 feet of the original earth, which contains a great deal of vegetable matter.

#### INDIVIDUAL FARMS PROTECTED BY LEVEES.

In the vicinity of Hillview there are three tracts of land which have been leveed by owners without the aid of the State law. (Pl. X.)

The Hartwell ranch, containing an area of 4,000 acres, was leveed in 1889. The levee was cheaply constructed, having steep slopes and a narrow top and the greater part of the dirt being taken from the inside. The land inclosed receives a large amount of bluff water, and several dredge ditches have been made for the interior drainage. During low water drainage is effected through a sluice gate into Apple Creek. During high water the gate is closed and the water is raised with a Menge pump, but it has not sufficient capacity to remove the water as rapidly as it collects. The levee was broken by waves during the flood of 1904 and the ranch was flooded.

The Roberts ranch, situated between the Hartwell ranch and the river and covering an area of 3,000 acres, is entirely surrounded by levees whose construction was similar to those of the Hartwell ranch. The levee broke in 1903 and 1904, due to the action of the waves and of the water running over the top. This was the only point in the Illinois River levees where a deep crevasse was formed similar to those which occur in the Mississippi levees. The drainage water is carried by open ditches to the pumping station, which is on the river levee. The pumping plant consists of a 24-inch horizontal direct-connected centrifugal pump having a capacity of 1,200,000 gallons per hour.



SECTION OF  
BOTTOM  
OF  
DRENS



The Lowenstein farm, consisting of 600 acres, is protected by a levee built with a 2 to 1 slope on the outside and a  $1\frac{1}{2}$  to 1 slope on the inside, with a 4-foot top. The foundation was grubbed and plowed and the dirt was all taken from the inside. The land receives the bluff water from an area 1.5 miles long by 1 mile wide. During low water it drains by a gravity outlet. For high water a Menge pump with two wheels was provided. This plant failed because the pump could not be kept in working order, and so it has not been run the past two years. The levee broke in 1903, due, it is thought, to burrowing by muskrats. In 1904 the water stood for ten days within 1 foot of the top of the levee, but it did not break. Part of the land on the inside, however, became too wet for cultivation, because the pumping machinery could not be operated.

The levees have failed to fully reclaim these tracts of land from the following causes: In the Hartwell ranch the levee did not have a sufficient cross section, was poorly constructed, and the pumping machinery was not of sufficient capacity to handle the large quantity of water which came from the bluffs through the district. In the Roberts ranch the levee was not high enough, nor of sufficient cross section. In the Lowenstein farm the levee was not of sufficient height and cross section to withstand the water, and the pumping plant, though in place, was not in working order.

#### **WABASH RIVER.**

The lower Wabash River has a range of 21 feet between low and high water, the channel banks averaging 12 to 15 feet above low water. At various points along the river between Clinton and Vincennes organizations have been formed under the State laws and the work of protecting these lands from flood water has begun. The Brevoort levee at Vincennes was begun forty years ago, and has been in its present condition for sixteen years. All other reclamation work has been done within the past ten years.

A levee opposite Clinton protects 1,500 acres. This district is drained by gravity through an outflow culvert consisting of four 24-inch sewer pipes. During construction deep borrow pits were left on the inside of the levee and in times of high water they fill with seep water, but otherwise the drainage of the district is good. This levee failed in 1904. The maximum flood overtopped the embankment by 1.5 feet, but crevasses were formed before the flood height was reached. One crevasse was attributed to the effect of borrow pits and the others were probably due to faulty construction and insufficient cross section.

The Blocksom levee, near Terre Haute, was completed in 1904, and has not yet been subjected to a flood.

The Sugar Creek levee, on the opposite side of the river from

Terre Haute, protects 1,500 acres. This was built at a slope of 1½ to 1 on each side with a 6-foot crown raised 1.5 feet above high-water mark (fig. 90). The district has gravity drainage through one 42-inch and one 24-inch outflow culvert.

In the west part of Sullivan County there are two levees. One, the Island levee, near Sullivan, is 8 miles in length, protecting an area of 6,000 acres. The other, the Gill Township levee, protects an area of 12,000 acres. The cross sections of these levees are the same as the Sugar Creek levee described above. Considerable water passes through these districts and each has several outflow culverts, the

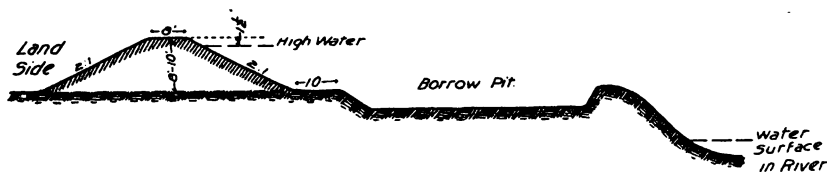

FIG. 90.—Specified section of Sugar Creek levee.

larger ones being 3 feet in diameter, constructed of masonry. In the Gill district two Menge pumps, each of 500,000 gallons per hour capacity, are now being installed.

The Brevoort levee at Vincennes protects 12,000 acres. It has a slope of 2 to 1 on the river side and 1½ to 1 on the land side, with a 3-foot crown raised 4 feet above high-water mark (fig. 91). This district is drained by two large ditches which discharge under the levee through stone outflow culverts 3 feet in diameter. During high water the low part of the district is flooded by back water, and a pumping plant is necessary for complete drainage. This levee was

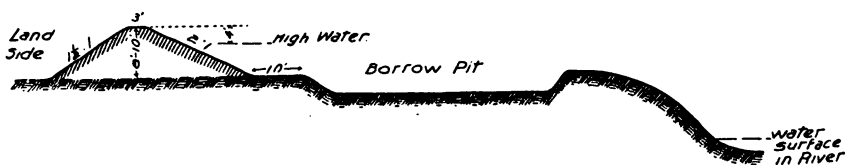

FIG. 91.—Specified section of Brevoort levee.

the only one on the river which withstood the 1904 flood without a crevasse, although it required constant patrolling and strengthening of weak places to hold it intact.

#### MISSISSIPPI RIVER.

Along the Mississippi River the larger tracts of bottom lands usually lie opposite the bluffs nearest the river, but in some localities there are extensive flats on both sides of the stream which are more or less cut up by old channels and bayous that in high water become navigable, but in low water either dry up entirely or become lakes

and sloughs of stagnant water. The soils of these bottom lands vary from a black "gumbo" to a coarse sandy loam, a light sandy loam being the more common. They are all very fertile and when cultivated yield large returns of corn and vegetables.

The average fall of the reaches of the river which border the lowland is approximately 6 inches per mile. The river has a rise and fall of 23 feet, the high-water period occurring from March to June. During low-water period the river is approximately 0.5 mile wide, while during high water it varies from 1 to 6 miles. The low-water channel has been improved for navigation by wing dams built out from the shore and by dams thrown across the head of side channels and bayous, the object of these structures being to concentrate the water in the main channel and keep it free from bars by the eroding force of the water.

On both sides of the river these bottom lands have been partially reclaimed by organizations under the State laws for drainage purposes, by the United States Government for river improvement, or by a combination of the two for drainage and river improvement.

#### MEREDOCIA FLAT.

At Albany, Ill., is a section of lowland known as the Meredocia flat, bounded on either side by highland and extending from the Mississippi River to Rock River. Previous to its improvement the water of either river at flood time flowed through this flat. During low-water periods it formed a continuous string of sloughs. The land was improved in 1897 by the

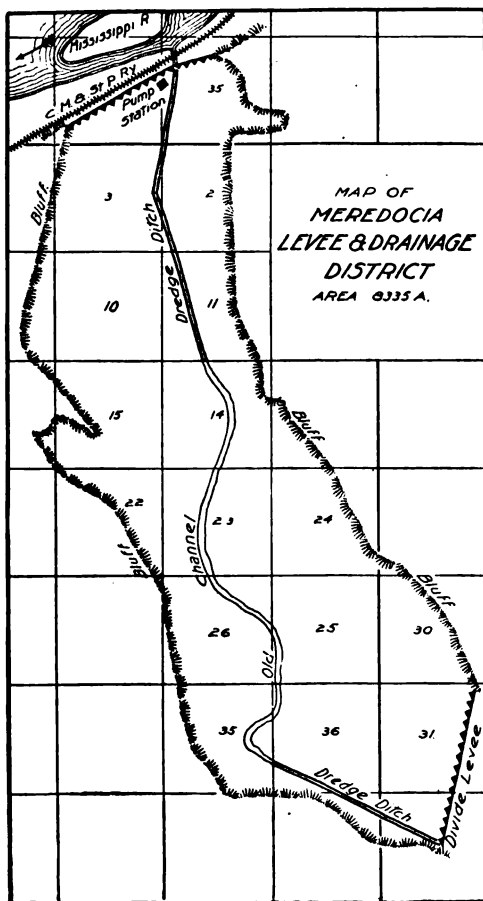

Fig. 92.—Map of Meredocia levee and drainage district.

Meredocia levee and drainage district. (Fig. 92.) On the divide between the two rivers 7,800 feet of levee with a maximum height of 8 feet were built to prevent the flooding of the district by Rock River.



A levee 7,400 feet in length, with an outside slope of 3 to 1, inside slope of 2 to 1, 10-foot crown, and maximum height of 23 feet, was built at the lower extremity of the flat to shut out the Mississippi River floods. In the bed of the flat the levee was built on a natural foundation of 7 feet of "gumbo" underlaid by sand and gravel. A muck ditch constructed under the entire length of the levee and the embankment itself were built of "gumbo." Twenty per cent was added to the height for shrinkage. During low water drainage is through an outflow culvert consisting of two 48-inch pipes. During high water drainage is effected by a 30-inch horizontal centrifugal pump direct connected to a double vertical engine, the pump having a capacity of 1,500,000 gallons per hour. While the district contains an area of only 8,000 acres, it is estimated that the drainage of 25,000 acres is handled at the pumping station. During extreme high water a few "boils" have developed in the flat. With these exceptions the levee has since its construction withstood all floods without any special patrol or repairs and is in good condition. All of the land is not thoroughly reclaimed for the reason that it has never been sufficiently ditched to make good farm land of the lowest part of the flat, yet many acres have been redeemed, and the entire district is sufficiently drained for meadow land.

#### MUSCATINE ISLAND.

Muscatine Island is a 20,000-acre tract near Muscatine, Iowa (fig. 93), cut off from the highland by an old river channel known locally as Muscatine slough. The surface differs from the lowlands usually found along the river in that it is more undulating, the sand ridges on the upper end of the island rising in many places above high water, and there is one quite prominent sand hill near the river bank. The land contiguous to the slough is low and flat. An attempt to protect this island from flood water was begun as early as 1858, but on account of legal difficulties work was discontinued until about twenty years ago, when it was again taken up and completed.

A levee was constructed along the river bank from the head to the mouth of the slough. At the upper part of the island for a distance of 4 or 5 miles the only work done was to fill in the low places between sand ridges. At first the lower end of the island was left open between the mouth of the slough and the bluff, but experience soon proved that the plan was faulty, as the flood water from the river backed up the slough, caused it to overflow, and flooded the lowlands of the island. To prevent this a levee was built from the river to the bluff a short distance above the mouth of the slough. The drainage of the slough was provided for by an outflow culvert, consisting of three 36-inch pipes laid in the bed of the old channel under the levee. At present there are 13 miles of levee, ranging in height from

zero to 12 feet, the maximum height occurring only in the lowest places. The levee was probably built at a 2 to 1 slope on each side with a 4-foot crown, which was a small cross section for sandy material. Erosion and settlement have reduced this section until the levee is prevented from breaking during extreme high water only by the vigorous efforts of residents. At high-water periods the valves at the outflow culvert close and the slough acts as a reservoir to hold

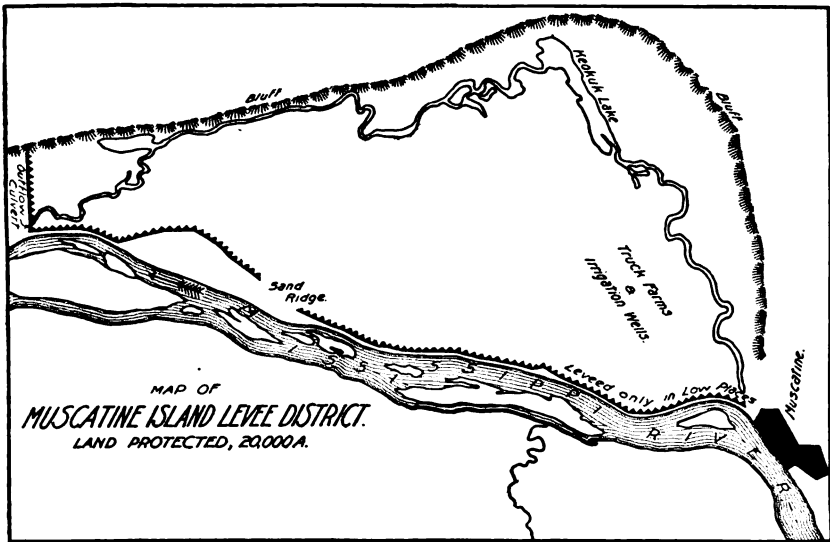

FIG. 93.—Map of Muscatine Island levee district.

the storm water until the river falls sufficiently for the valves to open and gravity drainage to begin. As a result there is a great deal of land lying along the slough too wet for cultivation.

#### MUSCATINE ISLAND IRRIGATION.

In the southern part of the district ordinary field crops are raised, but in the northern part, near Muscatine, vegetables and melons are the principal products. On account of the sandy nature of the soil and the rapidity with which it dries out in summer irrigation was tried in 1894 and has since been practiced more or less extensively.

An irrigation well consists of a pointed 8-inch pipe driven approximately 20 feet into the earth, in which the water stands 9 to 12 feet below the surface during the irrigation season. The part of the pipe which extends down into the water stratum is perforated with slots one-fourth inch wide and 12 inches long, staggered so as not to weaken the pipe. On top of the well pipe is attached a collar, to which the pump is bolted. Some of the wells consist of three or four 4-inch pipes connected at the top in place of one 8-inch pipe. Centrifugal

pumps with 5-inch and occasionally a 6-inch discharge are used. The pump is mounted on a cast-iron frame bolted to two timber sills which rest in two small trenches dug in the earth. The suction pipe is bolted to the collar of the well tube. The pump can be moved on a small sled from one well to another in about three hours. Power is furnished by a portable engine. The cost of a well, complete, is \$75, and of a 5-inch pump ready to attach to it, \$145. The engines used are either secondhand thrashing engines or those kept for other purposes. No record has been kept of irrigation operations, so that the data collected are those furnished by the gardeners from memory. The average cost of irrigating is as follows:

<i>Cost of irrigation.</i>	<i>Cents per hour.</i>
1 man to run engine.....	20
1 man to tend water.....	12.5
Fuel.....	22.5
	55
Total cost of running pump one hour.....	55
Area irrigated in one hour, 0.5 acre.	
Total cost of irrigating 1 acre, \$1.10.	

During the summer of 1900, the last extremely dry season, 14 pumps were operated and approximately 1,000 acres irrigated. As the irrigating plants are not used every year, and during only a part of the season in dry years, there is no special preparation of the soil for irrigation.

The well is located on the highest part of the area to be watered. The pump is started, and a head ditch is made with a plow, the water following in the furrow after the plow. When the head ditch has been carried as far as it is desired to take the water, the water is turned down between the rows at the lower end of the head ditch. As soon as it has reached the farther end of the rows the head ditch is dammed and the water turned between new rows, thus working from the outer end toward the well.

Forty acres have been irrigated from a single well, but usually 10 to 15 acres is as large a tract as can be economically watered from one well. Water is applied one to three times a season. The crops irrigated are sweet potatoes, tomatoes, cabbage, watermelons, and cantaloupes. The cash value of the crops varies from \$35 to \$200 per acre with an average of \$60 per acre. Everyone interviewed on the subject considers it a paying investment to have an irrigating plant installed so that it can be used any time a crop is in danger from drought.

#### FLINT CREEK-IOWA RIVER LEVEE.

From 1894 to 1900, 35.25 miles of levee were built on the Iowa side of the river by the United States Government for river improve-

ment (fig. 94). This levee begins at the bluff and extends down the south bank of the Iowa River to its mouth, thence down the

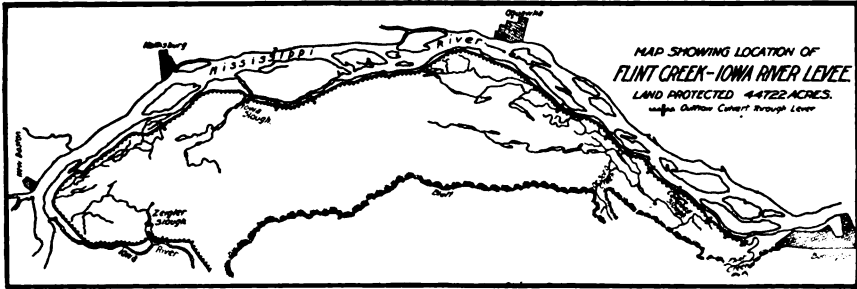

FIG. 94.—Map showing location of Flint Creek-Iowa River levee.

Mississippi to Flint Creek, where it again joins the bluff, thus protecting 44,000 acres from overflow. It was constructed with a

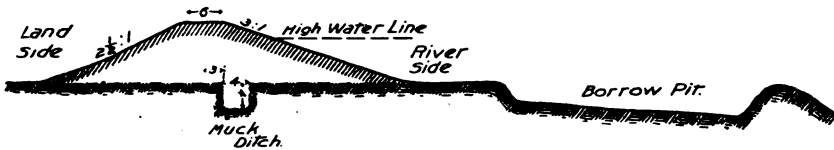

FIG. 95.—Specified section of enlarged Flint Creek-Iowa River levee.

3 to 1 slope on the river side throughout its entire length. The first sections constructed had a 2 to 1 slope on the land side with 4-foot crown, but the last sections had a 2 to 1½ slope with 6-foot crown (figs. 95, 96, and 97).

The foundation was cleared of all vegetable matter, grubbed, and thoroughly plowed, a muck ditch 4 feet deep and 4 feet wide constructed where considered



FIG. 96.—Flint Creek-Iowa River levee—section on firm land which did not fail.

necessary, and the slopes at completion were smoothed off and sown in grass. Mile posts were set in the crown and iron bench marks on the land slope near the mile posts. Since construction, sections exposed

to wave action and not protected by growing timber have been ripped.

In 1903 occurred the highest flood ever recorded at New Boston, which is near the upper end of this



FIG. 97.—Flint Creek-Iowa River levee—section exposed to waves, protected by riprap, has never failed.

levee. At that time the levee was patrolled and weak places strengthened. At no point was a crevasse formed, although 23 weak places

developed. These were caused by seepage and sloughing on the inner slope in the high sections of the levee (figs. 98, 99, 100, and 101).

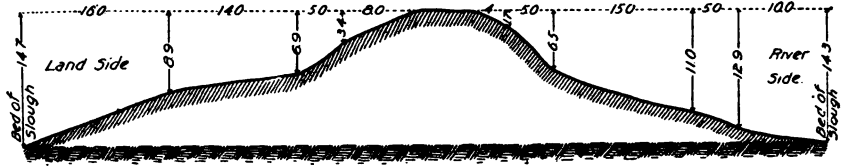

FIG. 98.—Flint Creek-Iowa River levee—section where slough occurred on inner slope, afterwards strengthened by banquette.

The drainage of the land back of this levee is by gravity, outflow culverts being constructed through the levee at different points.

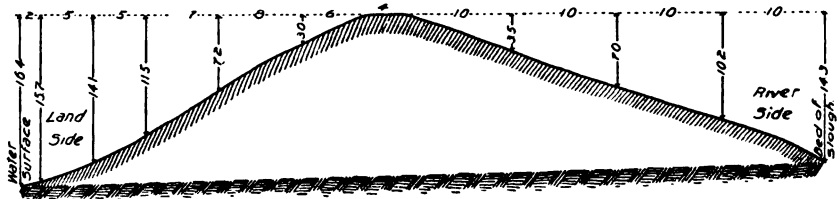

FIG. 99.—Flint Creek-Iowa River levee—section at northern part of Ziegler's Slough, sloughed in 1908.

Each culvert is composed of one to four 36-inch pipes with automatic

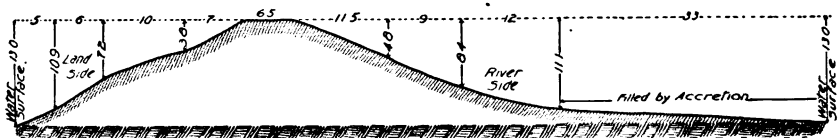

FIG. 100.—Flint Creek-Iowa River levee—section at Iowa Slough, where sloughing occurred in 1903.

valves. The sloughs and channels act as reservoirs to hold the storm water until the river falls and the valves open.

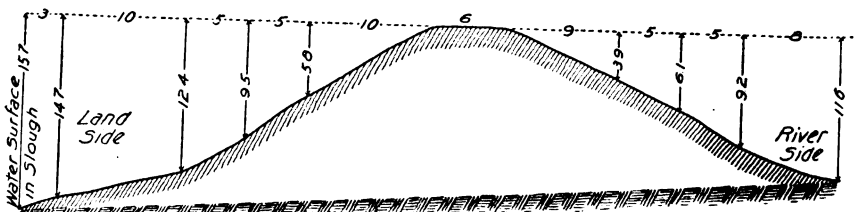

FIG. 101.—Flint Creek-Iowa River levee—section at Campbell Slough, where sloughing was checked in 1903 by sand sacks.

WARSAW-QUINCY LEVEE.

This extends from Warsaw along the Illinois bank of the river to Quincy (fig. 102). It was constructed and is controlled by three

separate districts: The Hunt district, extending from Warsaw to the Adams County line; the Lima Lake district, from Adams County line to the mouth of Bear Creek, thence along the north bank of the creek to the bluff; and the Indian Grave district, from the bluff on

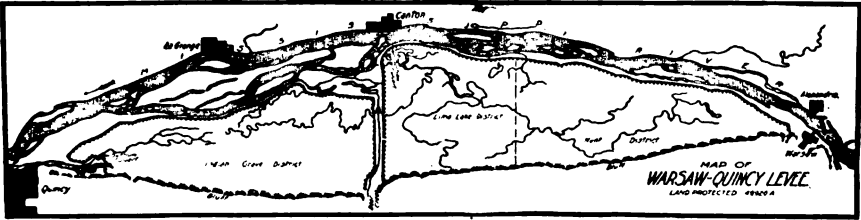

FIG. 102.—Map of Warsaw-Quincy levee.

the south side of Bear Creek; thence down the river and across to the bluff at the head of Quincy Bay.

Several years after the levee was constructed a muck ditch was put in at the foot of the outer slope and the embankment strengthened by the United States Government. The cross section is 3 to 1 slope on the outside and 2 to 1 slope on the inside, with 6-foot crown. The greater part of the levee is built of a sandy loam in which the sand is very fine. For 2 or 3 miles at the Warsaw end the material is very sandy, but the sand is coarse, and this section is said to be the best in the Hunt district. There is an occasional section of gumbo, which has never given any trouble.

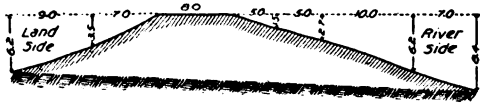

FIG. 103.—Hunt district levee—section where crevasse occurred.

During the flood of 1903 the Hunt levee broke in two places, caused by lateral pressure (fig. 103). Several other breaks occurred in this and in the Lima Lake district, but they were due to water

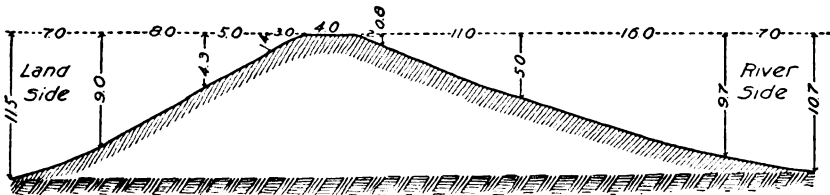

FIG. 104.—Indian Grave district levee—section where Houghton crevasse occurred.

on the inside after the districts had flooded from the preceding breaks. The Indian Grave levee broke at Houghtons Landing when the water was 4 feet below the top of the levee (fig. 104). Several other breaks occurred in this levee, caused by the water on the inside, which came from the previous break.

A waterway approximately 1,000 feet wide was left for the flow of Bear Creek between the Lima Lake and Indian Grave levees (fig. 105). There is no distinct channel in this waterway, and it becomes overgrown with weeds and bushes; when the creek rises the growth obstructs the flow of water and causes it to overtop the levees. This waterway has a grade of 4 feet per mile, which causes a ready flow in the ditches along the levees, and as a consequence the districts have been at considerable expense to prevent the water flowing down the borrow pits and washing out the levees. By plowing each year in the center of the waterway a good channel is being made which in time will be large enough to carry the water, as the channel erodes rapidly after it has once been cut through the "gumbo" to the sand strata. On account of the heavy deposits of sediment in the waterway, the levees have been raised several times.

The storm water of Hunt and Lima Lake districts is discharged through outflow culverts, made of 4-foot pipe fitted with automatic

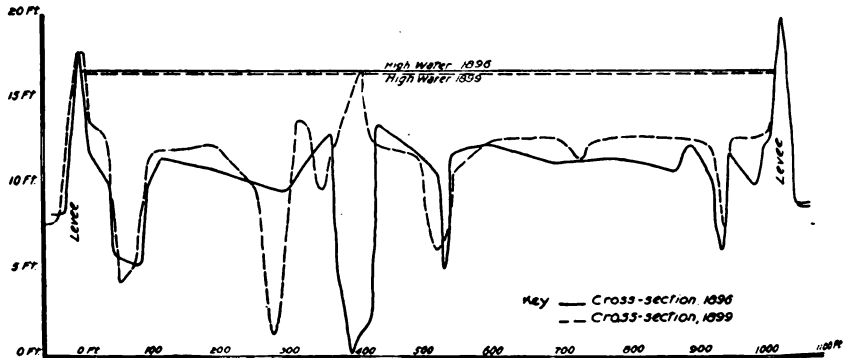

FIG. 105.—Section across Bear Creek waterway.

valves, located near the mouth of Bear Creek. The Indian Grave district drains through similar culverts into Quincy Bay. The interior sloughs and old channels act as reservoirs to hold the storm water until it can escape by gravity. Some dredge ditching has been done in Lima Lake district, but because of poor outlets it has been of no benefit. Much valuable land is rendered unfit for cultivation on account of these interior sloughs overflowing during long seasons of high water.

#### SNY ISLAND LEVEE.

The Sny Island levee and drainage district was organized in 1871 and the levee constructed in 1872-73 (figs. 106 and 107). The levee begins at Bluff Hall, on the Illinois side of the river, and extends to Hamburg Bay, a distance of 52 miles, protecting 110,000 acres, of which 90,000 are in cultivation. The district is drained by an old channel called the Sny, which leaves the river near Bluff Hall and

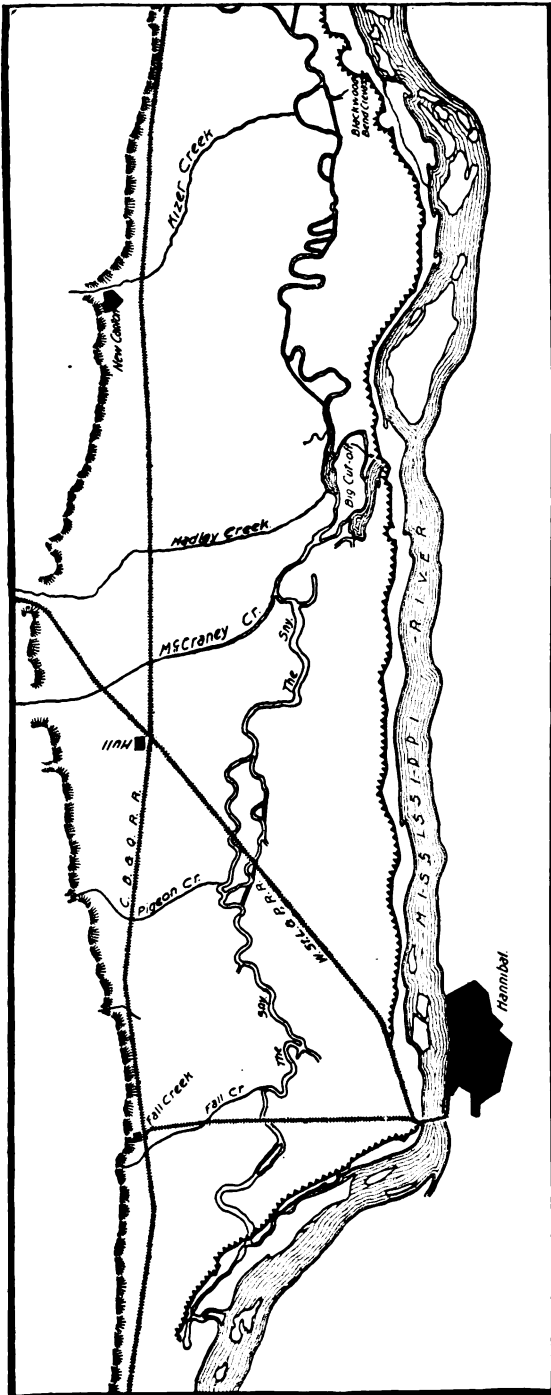

FIG. 106.—Map of a part of Noy Island levee and drainage district.



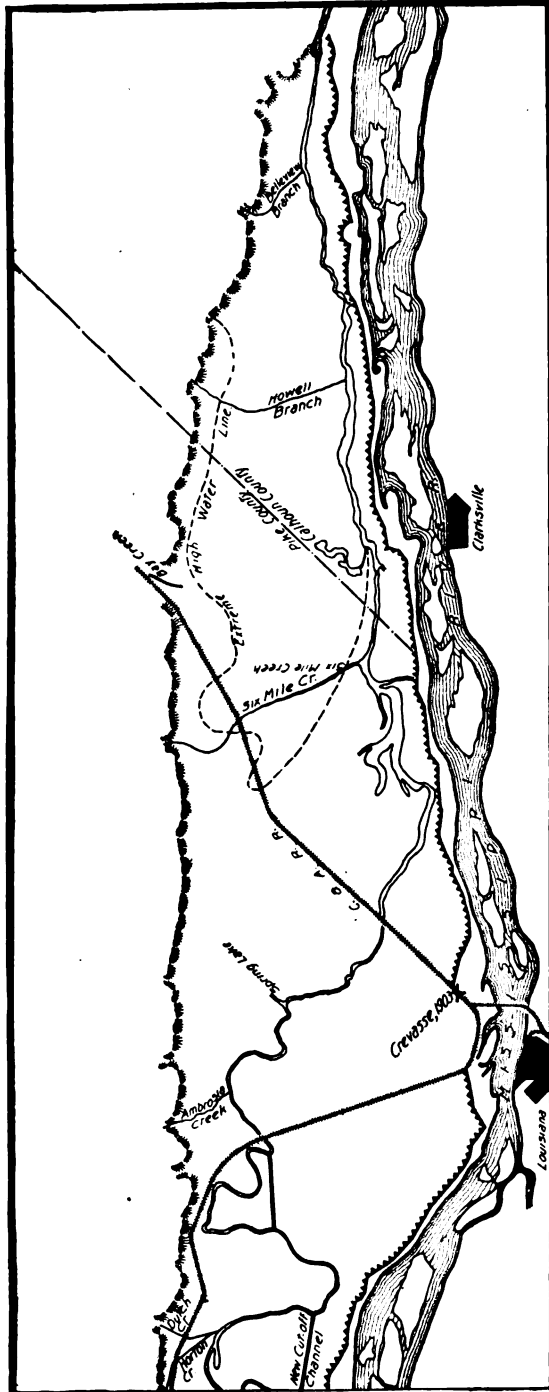

FIG. 107.—Map of a part of Sny Island levee and drainage district.

empties into Hamburg Bay. It was originally connected with the river between Bluff Hall and Hamburg Bay, but the head of the channel, as well as all other points along its course, were cut off by the levee, so that the only connection the Sny has with the Mississippi at present is at the mouth of the former through Hamburg Bay. The district is open at the lower end and that part is flooded each year by backwater.

The levee was originally built with a 3 to 1 slope on the river side and a 2 to 1 slope on the land side, with a 5-foot crown. The average height for its entire length was 8.2 feet. The specifications called



FIG. 108.—Sny levee—section across old channel, known as the cut-off, public road on the crown.

for the foundation to be cleared of all timber and vegetable matter and thoroughly plowed after the stumps and brush had been grubbed and for a muck ditch 18 inches wide on the bottom and 3 feet deep, filled with black dirt. Subsequent events proved that the specifications had not been complied with in regard to the muck ditch and the clearing, grubbing, and plowing of the foundation, and the borrow pits which were opened up in many places near the foot of the inner slope were a source of continual trouble and danger until they were refilled. During the first few years after construction the levee was frequently broken by floods. In time the height was raised, the

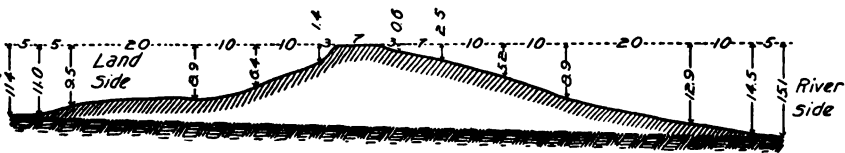

FIG. 109.—Sny levee—section near Hannibal, Mo., public road on banquette.

inside borrow pits filled, and the slopes flattened or strengthened by a banquette, so that the levee held intact from 1888 to 1903. The Louisiana crevasse of the latter year was over 300 feet wide and 60 feet deep and cost the district \$25,000 to refill. Up to 1894 more material had been used in repairing and strengthening than had been used in the original construction (figs. 108 and 109).

A history of the construction and maintenance of the levee up to December, 1893, was given in the testimony to the courts in the Sny Island bond suit by H. P. Dodge, who during construction worked on the levee as an employee of the contractor and later as a subcon-

tractor, and since construction has been on the levee an average of three months each year and has repaired several of the breaks. He testified in effect as follows:

When the contractors first began work the specifications were carried out, but they soon began slighting their work. The engineers passed over the ground between 8 and 10 a. m. and 3 and 4 p. m. Between times the contractors would cover up stumps, logs, and brush, refill the muck ditch with sand and vegetable matter that had been thrown out of it, and poorly plow rooty ground. These defects would be covered up and look all right when the engineers came along. When the freezing weather came on the muck ditch was omitted entirely and the plowing was more poorly done. The inside borrow pits were often worked out 6 to 7 feet deep and everything was hauled into the levee that would make a bank. The big cut-off was filled during the winter of 1872-73. Piles were driven and brush filled in to keep the bank from sliding. South of Black Wood Bend the levee was built on top of roots and drift sand.

The levee as originally built was not high enough nor wide enough and the slopes were too steep. The deep borrow pits on the inside were extremely injurious, and the failure to complete the muck ditch and clear the foundation of vegetable matter has been the cause of serious trouble. After construction seepage caused by trash in the foundation of the embankment came out at one point on the inside of the levee and finally resulted in a crevasse. Before the Goodman crevasse occurred springs were formed on the inside, and when the break came it washed the levee away, but it did not wash out below the original surface, showing that the ground had not been plowed. In a distance of 300 feet along this break there were 22 stumps 2 to 4 feet high. The break at Government Circle revealed the fact that the muck ditch had been omitted, the brush not removed, and the ground not plowed. Before the crevasse developed at Murphys Bay the water came through between the surface of the ground and the levee, where there was a layer of decomposing vegetation.

The breaks of 1876 and at Black Woods Bend were repaired in the following manner: The ground was cleared and well plowed, a muck ditch dug 3 feet deep and 3 feet wide, which was refilled with black earth well tamped, and the levee constructed with a 3 to 1 slope on each side. The Government used the same method in repairing the break at Murphys Bay. None of these repairs has given any trouble, although in the most treacherous places along the levee.

E. J. Chamberlain, who had been engineer of the district since 1884, testified in effect as follows:

There were defects in the original location and construction of the levee. In many places it was located so near the bank of the river that material for its construction had to be taken from the land side. The opening up of these land-side borrow pits, which are 2 to 6 feet deep, has been the cause of much trouble and expense, as quicksand was often exposed and when the surface soil was removed there was nothing to hold the quicksand in place. The hydrostatic pressure forces the water through the quicksand, forming springlike streams, when the work of destruction is rapid. The crevasse of 1876 came from this cause alone. In many places it would have been better if the levee had been far enough from the river so as to have left a fore shore of timber and brush as a protection from wave action, as where the levee is located near the river and not protected by brush and timber great injury has been done to the slopes by currents and wave action.

The errors of construction may be placed under four heads: (1) Insufficient grade; (2) insufficient preparation of foundation; (3) insufficient cross section; (4) improper location of borrow pits.

The original notes show that the data for determining the grade of the crown were the high-water marks of 1851 at Hannibal and Louisiana. The difference in elevation between these marks gave a grade line of less than 6 inches per mile for that flood plane of the river, and this was adopted as the grade line of the levee crown. No allowance was made for any change, such as confining the river within a narrower channel, as at the Hannibal and Louisiana bridges, where the width of the river at flood height has been reduced from 6 miles to something less than 1,500 feet.

Theoretically the river is supposed to descend at a certain grade, but that is affected by circumstances. For instance, a sudden rise in Salt River causes the plane of high water in the Mississippi River immediately below the mouth of Salt River to raise above the uniform plane, the water becoming "piled up," as we say in common parlance. While agreeing to the theory that water will find depth when the banks are contracted, there are reasons for believing that the water is higher at Hannibal and Louisiana than in 1872. The effect of narrowing the channel at these places, as found from notes actually taken in the field in 1888, and also in 1892 at the time when the river was at or near its highest stage, has been to elevate the plane of water at these points, and there has also been more or less change in the grade of the water at other points. Above the Hannibal Bridge for 4 or 5 miles the plane or surface of the water is level, and at another place at the head of the levee it is nearly level. Then there is a section below the Hannibal Bridge where there is a fall of 2 feet or more. In a number of places between Cincinnati and Louisiana there are reaches of the river extending for half a mile where the plane of the river was level, as observed in 1892, then there would be a rapid fall for a short distance. Above the Louisiana Bridge it is level for some distance. While local conditions cause the grade to vary at different points, the average fall of the high-water plane from one end of the levee to the other is about 6 inches per mile.

The original grade of the levee was not even theoretically correct unless the levee had been composed of a hard substance that would have kept it up to grade and prevented burrowing animals from making tunnels 6 to 24 inches under the surface from standing water on one side of the levee to standing water on the other. Mole tunnels about 2 inches under the surface caused much injury to the levee in 1888 in localities of insufficient grade, where the water came to or within a few inches of the original grade.

The levee was not high enough. It was supposed to be to the high-water plane of 1851, but even that height was not theoretically correct, for it would be insufficient from the fact that the wind would throw waves over the crown, cutting the material away unless it were of stone. The levee would also settle and become much lower. It was found on rerunning levels over the levee that in one section, just above the head of Gilgal Prairie, for a distance of 3 miles the crown was 2 to 3 feet below grade. At another place for half a mile it was 2 feet below grade, and there were a number of other places where it was below the original grade. The plane of the water having been raised at the Hannibal and Louisiana bridges, the levee would have been insufficiently high to have withstood the 1851 water. It was known from working on the levee prior to 1888 that the sections above Hannibal were at the original grade. In that year the water was 6 inches to 2 feet above the crown of the levee where it was at the original grade, although records from other points on the river show that this flood did not equal that of 1851. In 1888 the grade of the origi-

nal levee was generally 2.5 feet below the 1851 water mark. To make a levee reasonably safe the grade of the crown should be not less than 3 feet above the highest known water. The present plans are based on a grade line established from the flood plane of 1888 and confirmed by the flood of 1892.

The next defect was in the preparation of the foundation. In filling around the old crevasses at Kings Lake and Bay Island some of the original levee was removed, and in the foundation were found stumps and vegetable matter which are very objectionable. Unless the foundation is cleared of all perishable matter, a seam will be formed and the new embankment will not become mortised to the ground, but will permit water to flow between the levee and the original surface. This has been observed in small embankments and was seen here in 1887, when the road on the inner berm had considerable water on it, all coming from under the levee. The river was high enough to have submerged the land with no levee, but not high enough to cause the water to percolate through the embankment. Seepage under the levee did not occur where the muck ditch had been made and the foundation properly prepared. All repair levees constructed since 1884 by the district or the Government have had all roots and connections between the river side and the land side cut off by muck ditches. The best way to form a bond between the new levee and the original ground is to make a ditch 4 to 6 feet wide and tamp with impervious material. This protects the joint and mortises the embankment.

Insufficient cross section means insufficient thickness and size of embankment, and a great deal of trouble has been experienced from this cause. In sections where there is quicksand the levee has been giving way on the land side by sloughing, but where the material is black clay or gumbo there has been no trouble from this cause. In regions of quicksand a levee will stand at only a very flat slope.

The improper location of borrow pits has further weakened the cross section. In many places borrow pits 6 feet deep were made within 10 feet of the levee on both the river and land sides. So far as the strength of the embankment is concerned this would have the effect of adding 6 feet to the height of the levee without sufficiently increasing the base. For instance, a levee 10 feet high of the original cross section would have a base of 55 feet, but if borrow pits 6 feet deep were dug 10 feet from the toe of each slope it would be equivalent to a levee 16 feet high, with a base of 75 feet, instead of 85 feet, as it should be.

It was found from observation that the river banks and also the levee itself, where exposed to wave action, took slopes of their own varying from 4 to 1 to 8 to 1. Nature's slopes were adopted as far as the district was able to pay for them. In 1888, a new grade line and system of construction were adopted after study of the high-water plane for that year, and it was decided to make the slopes on the river side 3 to 1, 4 to 1, and 5 to 1, depending on the location. Where there was a good foreshore of timber and brush and the levee composed of impervious material, 3 to 1 on the river side and 2 to 1 on the land side were sufficient, but where exposed to wave action a 5 to 1 slope on the river side was decided on. In regions of quicksand a 4 to 1 slope on the land side has been used. This slope has not been carried quite to the top of the levee on account of expense, but as high as there was likely to be percolation from the river.

To keep the quicksand in place a coating of heavy material 2 to 6 feet deep and 10 to 20 feet wide was placed over the land side borrow pits. Where practicable material was hauled from the river side of the levee, otherwise it was obtained on the land side some distance back.

Bushes growing on a levee are an injury, as the roots penetrate the embankment and, decaying, leave an opening for a waterway through the levee. They also prevent the detection of weak places in time of high water.

The action of the elements is always a source of great danger, wave action being especially injurious. Burrowing animals are also a constant menace to safety. It is absolutely necessary to provide for the repairs of a levee as it would not be safe to put up an embankment for flood protection and then give no attention to its maintenance.

To protect a levee in time of high water requires constant watching because the material of which it is built is not such as would be used in building a reservoir for constantly retaining a body of water. Where construction is defective more vigilant watching in time of danger is necessary than if properly built.

In a general way the commissioners and all interested prepare to protect the levee in times of danger by organizing a patrol and getting materials, such as sand bags, burlap, brush, and straw in readiness. Loose-woven burlap spread over the slope and held in position by sand bags has been found to be the best means of stopping sloughing. Several times overtopping has been prevented by setting on edge boards 1 foot wide; in a few places a second board has had to be added to the first. As the danger increases the patrol is increased and is kept going night and day from one end of the levee to the other. The levee is divided into districts which are subdivided into 1-mile sections. An occasion requires the landowners turn out and give assistance. In 1892, a large body of men had to be secured in a short time and many were obtained from outside the district. Many residents of the district who could not go personally sent help or supplies. In that year \$14,000 was spent in patrolling and strengthening the levee.

From the completion of the levee to 1888, there were 18 breaks which destroyed altogether 4.1 miles of the old levee. The large breaks were repaired by circling around the old crevasses. On account of the extra length this involved, 4.8 miles of new levees were required, 3.3 miles being on new location which required new right of way. None of the new work has given any trouble.

The Government has placed some dikes in the river for improving navigation, but they have little or no influence on high water.

The United States engineer's report on the high water of 1903 says of the Sny levee:

Many boils and seeps were developed, but no danger of breaks. Where there was a good wide banquette on the inside, boils and seeps were eliminated and the ground solid enough to drive over with a wagon at all times. The danger of a break at Hannibal and the break at Louisiana were caused by using railway grades as a part of the levee.

#### **LEVEE CONSTRUCTION.**

In selecting a route for a levee care should be taken to locate on stable ground where there is sufficient room for borrow pits on the river side, to keep a foreshore of timber between the location and open water, to cross sloughs and old channels by the shortest courses, and to avoid places where the levee would be exposed to erosion by currents or waves.

The height should be not less than 3 feet above high-water mark. This is necessary to prevent overtopping of the levee by waves, by an unexpected rise in the flood plane, or by the lowering of the crown by the crossing of animals, erosion, etc.

The cross section required for a levee depends on its height, the material, and the length of time it is exposed to high water. An embankment of an impervious material does not need the cross section of one built of a material easily saturated and a levee of pervious material which would withstand a flood for five days might fail under the same height of flood if it continued ten days; this would depend upon the rapidity with which the material becomes saturated. The injurious effect of waves and currents is materially decreased as the slope is flattened and of burrowing animals as the area of the cross section is increased. A flat slope is cheaply maintained as grass

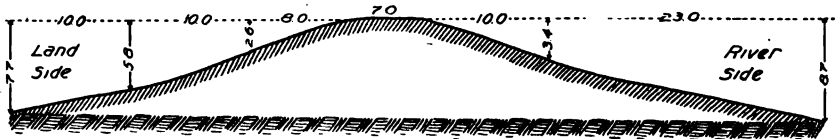

FIG. 110.—Hunt district levee—section of new levee built to cross crevasse.

grows more readily and is not injured by the tramping of animals, and vegetable growth can be kept down by the use of mowing machines.

In heavy material such as is found on the Illinois River it is desirable to make the slopes 3 to 1 on both sides. For the river side the most economical slope under all conditions is 3 to 1, but for the land side a 2 to 1 slope may have sufficient strength in the heavier materials, though it is believed that 3 to 1 would be more economical in the end. Where light material is used, such as is found on the



FIG. 111.—Proposed section of levee for closing the Houghton crevasse.

Mississippi, the greater bulk should be placed on the inside of the center of the cross section. The inside slope should not be steeper than 3 to 1 and in some localities it is necessary to increase this to 4 to 1 or to reinforce the land side by a banquette, the top of which should be kept 8 feet below the top of the levee. The width of its crown may vary from 20 to 30 feet. The inside slope below high-water line should be not less than 3 to 1 and, in some special cases, should be increased to 5 to 1. In a few places on the Warsaw-Quincy levee the inner slope has been increased from 2 to 1 to 4 to 1. In the Sny levee the old 2 to 1 slope has been strengthened by a 24-foot banquette or increased to a 4 to 1 slope (fig. 112). In places

where exposed to wave action the river slope of 3 to 1 has been increased to 5 to 1.

In levee construction on the lower Mississippi, 8 feet has been accepted as a common top width, but 6 feet is thought sufficient width for the levees just described. Many levee builders now advocate adding 1 foot vertical to the crown and grading to an apex (fig. 112). The object of this addition is to furnish a supply of material on top of the levee for use in emergencies, to induce moles and muskrats to burrow above the high-water plane, and to increase the height of the levee against an unforeseen rise in the flood plane.

The underdrainage of farms and the improvement of creek channels in the uplands concentrate the storm water and deliver it to the main drainage channels rapidly. In leveeing overflowed lands large areas which have served as reservoirs to hold the water and deliver it gradually to the streams are cut off, as well as channels and currents occurring throughout the overflowed area. After these improvements have been made the same amount of water must necessarily pass through a narrower channel in less time. Under this condition the velocity of the stream increases, and observations indicate that the

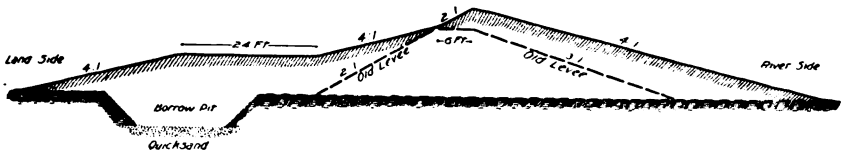

FIG. 112.—Section showing plan for improving the original Sny levee.

flood height is also raised. Hence the following conclusion may be drawn: The ordinary improvement of land within the watershed of a stream tends to raise the flood plane of the stream and decrease the duration of the flood. In constructing levees along streams where large projects of improvement are likely to be carried out in the future the structures should be planned to provide, as far as possible, for this increased rise.

The greater percentage of levee failures are due to using cross sections barely sufficient to hold floods under ordinary conditions. During the unusual high water of 1903 on the Mississippi and of 1904 on the Illinois and Wabash the leveed lands were flooded because no preparation had been made for those exceptional conditions. The levees were patrolled and weak places strengthened, yet these precautions were ineffectual because the levees were of such small cross sections that every trivial injury to the original embankments produced a serious weakness and there was not sufficient foundation nor material at hand to work with. In consequence much money and labor were lost in maintaining and rebuilding the levees, besides the damage done to property inside the district.



Levees are usually constructed with wheeled and drag scrapers. Slips are used in some of the smaller levees, and occasionally they are put up by wheelbarrows. The Coal Creek levee was successfully constructed with a 2.5-yard dipper dredge. The only objection to this method of construction is the large borrow pit which is necessarily left close to the levee. On a stream of slow current and tenacious material, such as the Illinois River, this is not objectionable, but along a stream with rapid current or through sandy material this pit might cause a current down the levee and lead to caving.

Near Hannibal, Mo., a section of the South River levee is being constructed by means of a hydraulic dredge. This section crosses gumbo land covered with water, where scrapers can not be used. The levee averages 14 feet in height. The borrow pit is kept at 150 feet from the toe of the slope. The gumbo varies in depth from 10 to 30 feet and is underlain by sand. The suction pipe of the dredge is kept in the sand, and as the gumbo drops down it is taken up with the sand, so that the material which goes into the levee is a mixture of gumbo and sand laid down in water. On account of the fluidity of the material as it leaves the discharge pipe, it is difficult to hold in place, but by using earth ridges and planks the embankment is raised to within 7 feet of the grade line and is then completed by scraping up the waste material with drag scrapers. The completed levee was put up for the same price per yard as sections of the same height with scrapers, and it has the advantage of containing an immense amount of waste material—100 feet on each side of the embankment. This material deposited along the foundation of the levee in swampy ground is of great value in the maintenance of the levee, and it also decreases the height of the levee actually subject to the pressure of the water.

This dredge will undoubtedly occupy an important field in future levee work, as it can fill up sloughs and low land where scraper work would be extremely difficult and expensive. It also has the advantage of constructing the levee without injuring the timber or making a borrow pit near the foot of the slope.

The foundation for a levee should be prepared by cutting all timber for a distance of 20 feet on either side of the toes of the slopes. Roots in the foundation should be grubbed to a depth of 3 feet and all vegetable matter removed. The foundation should then be plowed deep and thoroughly. A muck ditch should be constructed under the center of the levee of sufficient depth and width to cut through any vegetable matter, roots, holes, or sand strata which may lie under the surface. The object of the muck ditch is to unite the embankment to the earth and cut off any material which might cause seepage. This ditch may vary from 2 feet in width and 3 feet in depth to 4

feet in width and 12 feet in depth, its cross section depending entirely upon the kind of material through which it passes. It should be filled with the best material obtainable. The shallower ditches can be tamped by driving the teams across them, the deeper ones by leading a horse back and forth through them as they are filled.

Where the soil is tenacious and a muck ditch is not considered necessary, the foundation should be plowed outward, leaving a deep dead furrow in the center. A berm not less than 10 feet in width should be left between the toe of the slope and the edge of the borrow pit. When this is done the side of the borrow pit next to the levee should have a slope not less than that of the levee. In sandy or loose material or where deep borrow pits are to be made with a dredge the berm should be not less than 20 feet in width. Where there are strata of quicksand or unstable earth the slope of the borrow pit next to the levee should be as flat as practicable. Earth should not be taken from the inside if it can be avoided and never nearer than 60 feet in the best material. The pits should be shallow. Where levees are built with scrapers the material should be deposited in layers not exceeding 2 feet in depth so that it may be tamped by the teams passing back and forth over it. The embankment should be started at the full width of the slope stakes and carried to the crown at the width of the finished embankment, for it is not good construction to dump material over the sides.

The shrinkage of levees allowed by engineers varies from 5 to 20 per cent. Under ordinary conditions 10 per cent for scraper work and 20 per cent for untamped wheelbarrow work is sufficient, sandy material shrinking less than clay. On the Coal Creek levee the dredge work has settled only 3 per cent and the scraper work 10 per cent at the end of a year, and no further shrinkage was perceptible the second year. Oftentimes several feet of settlement takes place under the weight of the embankment. The heaviest settlement is liable to occur in the beds of sloughs.

For convenience in maintenance and description of localities mileposts should be set in the crown. A white post 3 by 4 inches, standing 3 feet above the crown and having the number of the mile painted in black, makes an economical and neat marker. A bench mark should be established near each milepost. A metallic post set near the toe of the inner slope would be more desirable, as it would be permanent. It should be set in such a position as not to be affected by the settlement of the levee.

After the levee is completed the slopes should be smoothed off and sown in grass. In latitudes where it will grow, Bermuda is the best, as it makes a thick sod and grows readily on slopes. In other latitudes a mixture of bluegrass and redtop gives better service. The bluegrass will grow on the upper part of the slopes and the crown,

while the redtop will grow on the berm and borrow pits. These grasses make a tougher and better sod than any other tame varieties. On levees which have been built with dredges some difficulty will be experienced in getting grass started, as the slopes are rough and uneven and the material on the surface has often come from the bottom of the borrow pit, but after the slopes have weathered two or three seasons they can be smoothed down and grass started on them. Observation shows that it is difficult to get grass set on slopes steeper than 3 to 1; however, occasional short sections of steeper slopes well sodded are found.

#### LEVEE MAINTENANCE.

On the completion of a levee efficient measures should immediately be taken for its maintenance. One of the first features to be looked after is the protection of the slopes from high water, currents, and waves. Where there is a foreshore of thick-growing timber there will not be much trouble from this source. Thick, small timber, which will not bend before the force of the water, is better than large timber, as it breaks up the waves more effectually. Where there is no native timber a good protection can soon be secured by planting willows, maples, and cottonwoods in and along the borrow pit. No timber should be allowed nearer the slopes than 20 feet, as the roots will penetrate the base of the levee, and when they decay will cause seepage. Occasionally a green root will cause seepage of water under pressure.

Another protection to the levee slope is a covering of tough sod, which retards erosion occasioned by rain storms, currents, and waves. The vegetable growth on the levee and berms on each side should be kept cut, since weeds growing and dying on the slope loosen the surface. Bushes also keep the surface loose and increase the danger of injury by waves and currents. Any neglected growth over the levee affords protection to burrowing animals, making it difficult for hunters to locate them.

Another method of protecting the slopes which is lasting but expensive is a revetment of rock 6 to 10 inches in depth laid over the exposed slope.

Muskrats do more damage to a levee than does any other animal, their nature being to begin their burrows below the water surface, continuing them into the bank 12 to 24 inches beneath its surface. Where water stands on both sides of the bank, as it does where a levee crosses a slough, they frequently make burrows from one side to the other not more than 2 feet below the surface of the embankment at any point. At no place is there any evidence that a rat has burrowed directly through an embankment. These burrows are a serious injury to a levee of small cross section with the crown near the flood plane

(figs. 113 and 114). Where the levee has ample dimensions they seldom cause serious injury. Where the burrows are numerous near the foot of the slope they frequently cause sloughing when the bank becomes saturated. Such animals as opossums, skunks, and ground-hogs may burrow in a levee to secure dry retreats, but their burrows

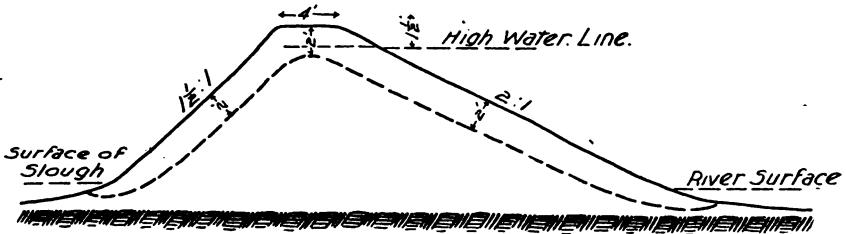

FIG. 113.—Section showing trace of a muskrat burrow across a levee of small section.

seldom extend through an embankment, the injury done by them being due to weakening of the cross section which permits seepage water to pass through more readily. Crawfish usually work straight down, and where there is a stratum of pervious material near the surface they work into it, causing seepage. An example of this may be

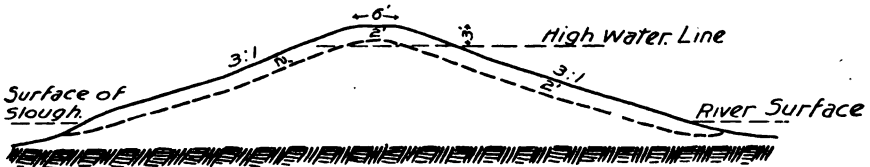

FIG. 114.—Section showing trace of a muskrat burrow across a levee of ample section.

found in the district back of the Warsaw-Quincy levee; this is underlaid by a sand stratum 6 feet below the surface from which water often flows through crawfish holes during times of flood (fig. 115).

There are many conflicting opinions regarding the pasturing of levees, and a special effort was made to obtain definite information



FIG. 115.—Section showing the formation of a boil inside of a levee.

on this point. In the Flint Creek-Iowa River levee pastured sections alternate with those bordering cultivated fields which are not pastured. In the former the 2 to 1 slopes showed more injury from the tramping and slipping of the live stock than the  $2\frac{1}{2}$  to 1 slopes. Cattle had also injured the steeper slope with their horns by tearing up the sod and loosening the surface. No injury, however, was

done on the 3 to 1 slopes. Where there were no fences trails were made transversely across the levee, which wore 6 to 10 inches below the surface, but they were narrow, easily located, and the depressions made by them are easily repaired.

Observations on small pastured sections of various other levees showed similar conditions. Where it is impracticable to keep down the growth of vegetation with mowing machines the levee should be pastured, since the injury done by live stock is less than that occasioned by an unchecked growth of weeds and bushes.

Where it is necessary to construct a fence on a levee it should either pass across the embankment at right angles to its course or parallel to it along the crown. The objection to all fences upon levees is that animals make trails along them, which are undesirable, especially on the slope.

The crown is sometimes used as a road, but this practice is objectionable, as in a 6 or 8 foot crown the edges are cut off by the wheels, ruts and chuck holes form low places, and in loose material fine particles are blown off by the wind, which in time materially lessens the top width and the height of the bank. Another serious objection is that in times of heavy rain storms the ruts collect the water, carry it some distance, and turn it down the slope, causing injury. The better place for a road is at the foot of the inner slope. If the levee has a banquette, the top of that makes an excellent roadway. Where it is necessary to use the crown of a levee for a road, the crown should be made wide.

An embankment built for railway purposes should not be included as part of a levee system unless it has been especially prepared for such use by placing a heavy layer of good material over the outer slope after a muck ditch has been put in at the foot of the old grade. A railway embankment is usually constructed on the surface without any preparation of the foundation, and in swampy lands layers of vegetable matter are often buried, which will prove fruitful sources of seeps if the grade is used as a levee. After construction, tracks are often raised and long trestles filled; timbers and old ties are buried and become sources of weakness in the bank. There can be no objection to a railway on top of a levee if the embankment has been prepared for levee purposes.

Experience in the management of levees has demonstrated quite clearly that they must be patrolled and inspected systematically. During the first year after construction the settlement of a levee should be looked after, particularly where it crosses sloughs or unstable ground, as settlement is liable to lower the crown below the flood plane. The best protection against burrowing animals is to occasionally patrol the levee with dogs, repair the injury done to the bank by animals, and keep the brush and weeds cut. During the

flood season the patrol should be increased so that any threatened weakness may be at once detected and strengthened. Where a levee is threatened by overtopping the crown can be raised by setting planks on edge, holding them in place by stakes, and backing them up with earth taken from the inner slope. Where there is a current sacks filled with earth may be used with good effect. Wave action can be checked by putting sacks filled with sand along the line of erosion. Cornstalks, brush, and lumber will also serve the same purpose when held in position by stakes and wires. Planks set on edge at the surface of the water and held on the outside by posts driven in the embankment, while the inside is packed with straw, have been successfully used.

Sloughing on the inner slope can be checked by packing brush or other material on the slope and holding it down with wire fastened to stakes driven in the berm and crown. Sheets of burlap stretched over the inner slope and held in position by stakes or sand bags are also a quick and effective remedy. When seeps are found they can be effectually cut off by sand bags if the location on the outer slope can be discovered. If not, it will be necessary to wall them in by sand bags from the inner slope, for which purpose the bags should not be filled quite full and should be laid around the seep in the form of a wall, within which the water will rise until it can do no more injury.

The most convenient material for levee repairs in an emergency is the sand bag. When practicable the bag should be filled with sand in preference to other material, as it is more quickly handled and is useful for any form of repairs. For walling in seeps and preventing sloughing and overtopping, any material with which the bag can be filled will serve the purpose, but to prevent cutting by waves and strong currents it is necessary to fill them with a material so coarse that it can not wash out of the bags. Sand bags used for this purpose should be placed systematically on the bank, so as to get the greatest good from the least number. Where it is necessary to build them up it is often advisable to lay one course header and the next stretcher, while under other conditions two courses stretcher could be laid to one header.

In repairing a large crevasse it is found more economical to build a new levee around the inside of the crevasse than to refill on the old line. This new embankment is semicircular in form and is known in levee parlance as a "circle."

The Indian Grave district specifies that in repairing small crevasses and slopes which have been injured by erosion the dirt shall not be taken nearer than 100 feet nor more than 200 feet from the toe of the levee on the inside, and never nearer than 25 feet on the outside. Before filling the base should be plowed down and outward, so as to

leave a deep dead furrow in the center. The end of the levee, where it can not be plowed, must be dug down. When necessary a muck ditch shall be dug or planks set on end for the purpose of uniting the new and old embankments. Unless otherwise specified the new fill shall have the same crown and slope as the old levee.

#### LEVEE FAILURES.

Experience has shown that the stability of a levee is dependent upon its location, cross section, material used in construction, and maintenance. If all these conditions were ideal there would be no levee failures, but in practice it is not often possible to get them. Locations must be used which leave the foundation and slopes exposed to erosion by currents and waves. Such material as is at hand must be used, and the funds available often determine the size of the cross section. The ideal material for levee construction is a heavy tenacious earth which will not erode or dissolve when subjected to the direct action of water and will resist percolation under hydrostatic pressure. Of the available materials found in river bottoms gumbo and " buckshot " are the best.

The material of the low land bordering the Illinois River is excellent for levee construction. It yields very slowly to the eroding action of running water and only small crevasses are formed in case the water breaks the embankment. A number of places were observed where the water had run over the top for several days without injuring the bank. Where crevasses had been formed the foundation of the embankment was not cut below the original surface. Even where the water had been running out from the inside through crevasses for weeks the material under and at the sides of the running water was solid, and it was necessary to use a spade to deepen the crevasses sufficiently to relieve the inclosed district of surface water.

Wave action causes the most serious injury to levees composed of this material. Where the levee is exposed to an expanse of open water, during a high wind the waves undercut the embankment at the surface of the water and dissolve the material. As the waves cut back into the levee the overhanging material falls into the water and is rapidly broken up and carried away, while the material above the point of the eroding force assumes a vertical position. The length of time a levee can withstand wave action is dependent upon the width of the levee at the water line and the intensity and duration of the storm. If the water is falling during a series of storms of short duration the slope will be worked into steps, the dimension of each step being determined by the stage of the water and the duration of the storm.

Much of the material of the lowland bordering the Mississippi River is a sandy loam, in which the sand is very fine. This is poor

material for levee construction, as it erodes rapidly under the action of water. A number of crevasses 500 to 1,000 feet in width were observed in levees of this material in which the inflow of the water had eroded the foundation 20 to 30 feet below the original surface. (Fig. 116.) The crevasses in the Warsaw-Quincy and Sny levees were of this nature, and also the crevasse formed in that part of the Roberts levee on the Illinois River, which had been constructed on a sand ridge. The material readily permits the percolation of water, and becomes soft and unstable when under hydrostatic pressure.

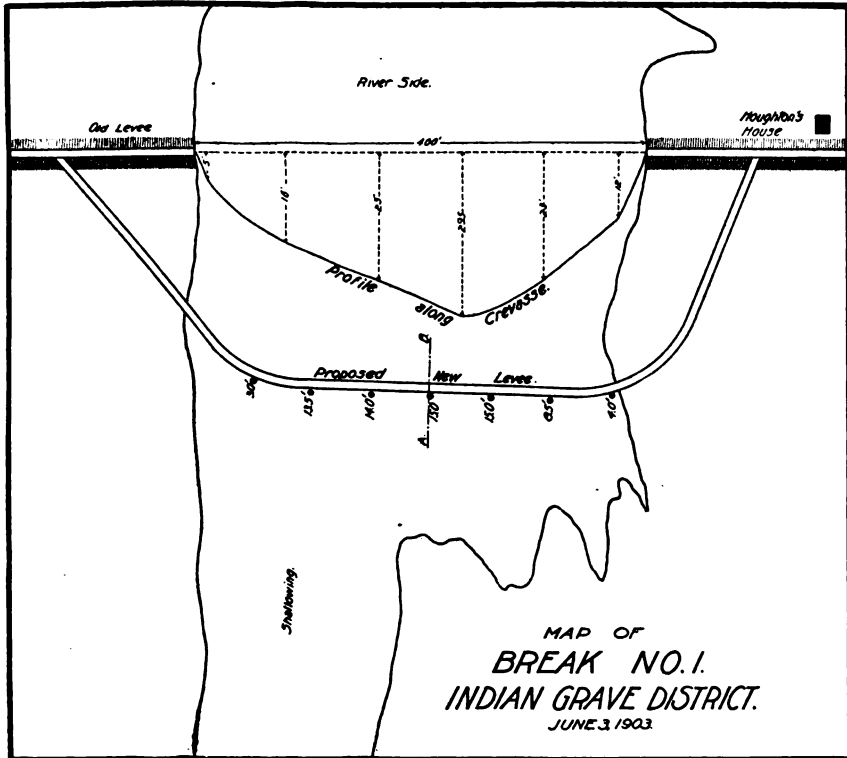

Fig. 116.—Map of break No. 1, Indian Grave district.

Embankments built of it, when subjected to long periods of high water, become trembling, shaking masses when disturbed, and so soft that long poles may be thrust down into them.

Waves cut rapidly into a sandy material, but the sand, not dissolving, will be rolled back, and thus the superincumbent mass will not assume a vertical form, but will be continually sliding down to the water's edge. Consequently, wave action is to some extent retarded by the material from above the water line and the slope is gradually flattened. A heavy sandy material will permit seepage, but it is



better than a sandy loam, since it is not so unstable. When cavities are formed it will drop down and fill them and for a time retard erosion.

Overtopping is due to the following causes: Insufficient height when first made, settlement after construction, or excessive and unusual floods. Overtopping is usually followed by crevasses, their size and the rapidity with which they are formed depending on the nature of the material. The failure of a number of the Illinois and Wabash river levees was due to overtopping.

Failure from seepage is due to water working its way through the levee under pressure, thus forming a small channel, which is enlarged by erosion until a crevasse results. In this way roots, burrowing animals, or a stratum of loose sand weaken the levee. Any material which will permit an opening through the levee or its foundation may be the cause of a failure from seepage. The cross timbers in the railway section of the Pekin-Lamarsh district caused the failure in 1902, the Houghton break on the Warsaw-Quincy levee was said to have been caused by a small hole through the levee, and numerous crevasses and dangerous seeps in the Wabash, Illinois, and Mississippi river levees owe their origin to animals or foreign materials. (Pl. XI.)

The crest of the levee is sometimes cut off by the waves and overtopping follows. The greatest damage from this source occurs after a crevasse has been formed and the area back of the levee has filled with water. This has occurred in several of the Illinois and Wabash districts. Where a direct current strikes against the slope it may cut off the crest and then overtop the levee, but when the river is at its lower stages the danger from erosion of banks arises from the undermining of the levee.

When saturation is the direct cause of failure the water running down the inner slope erodes the material and causes it to slough. This sloughing, not dangerous at first, may continue until the inner slope is weakened to such an extent that the crown sinks and overtopping results. Saturation indirectly causes many crevasses in levees built of light soils. It lessens the resistance of the material to the action of the water and facilitates seepage, so that any small weakness will be developed, resulting in failure that might otherwise have been averted.

Boils may occur near the toe of the slope and for an indefinite distance back. They are caused during high water by water-bearing strata lying below the surface. Where there is an opening to the surface pressure forces the water out in the form of a spring (fig. 115, p. 697). So long as the spring runs clear, there is no danger, but if it spouts muddy water sufficient material may be carried from under the

CREVASSE IN WARSAW-QUINCY LEVEE, WHERE THE EMBANKMENT HAS BEEN SWEEPED OFF.





levee to cause it to sink, and overtopping results. If these boils are seen in time, crevasses may be prevented by filling in on top of the levee as rapidly as subsidence takes place.

#### DRAINAGE.

One of the first problems to be disposed of in considering a project for the improvement of overflowed lands is the disposal of the storm water which comes from the higher lands back of the district. Where there are wide bottoms along streams having good falls it is often practicable to carry both the hill and the storm water of the district in a channel extending for a long distance near the foot of the bluff and parallel to the main river, finally discharging it at the lower end of the levee into the main stream. This is the plan of drainage in the Sny district and is common in the districts of the lower Mississippi. In many sections of the Illinois Valley this plan is impracticable, and it is necessary to lead small streams by the most direct route to the main channel. In order to accomplish this, frequent cross levees from the river to the bluff are required, which divide the reclaimed lands into districts, depending in size upon the width of the bottoms and the distance between the drainage systems that must be provided. Each district organized in this way is practically independent, being protected by its own levees, which extend along the river and laterally to the bluffs. This form is spoken of as a closed district to distinguish it from the open district of which the Sny is representative.

The location of the levees and boundaries of the various districts are shown on the accompanying plats. Some of the districts are almost entirely surrounded by levees, while others are leveed on two sides only. In an open district the drainage water is disposed of by ordinary gravity drainage, the only drawback to this system being that the land at the lower end of the district is necessarily flooded by the backwater from every overflow. The amount of land thus wasted depends upon the gradient of the river and the width of the bottom of the outlet channel.

In the closed districts the most serious problem is the disposal of the highland drainage, known as "hill water." When it has been concentrated into larger creeks or drainage channels before leaving the highlands, it can be carried through the bottoms in a channel leveed on both sides to prevent overflow during the seasons of high water. As a rule, these side streams have a good grade during the low-water period, and if a proper channel is constructed they do not overflow as long as there is no backwater from the outlet stream, but during high water, the flood plane being higher than the surface of the bottoms, the tributary stream is without grade from the point

where it enters the district, and hence its flood must be carried on top of the river flood. The difficulty of handling streams of this character arises from the silting up of their channels by reason of the sudden breaking of the current. The streams coming from the cultivated lands are heavily charged with sediment, and as they have a rapid gradient the silt is carried along until the current is broken by the backwater of the lowlands, when it is deposited and the channel rapidly fills, often causing the bed of the stream to rise until the water flows over the levees.

In constructing the Warsaw-Quincy levee it was necessary to lead Bear Creek directly across the bottom from the bluff to the river between the Indian Grave and Lima Lake districts. To do this, a waterway of 1,000 feet was left between the cross levees. This was thought to be ample for the highest water that could occur in the creek; yet the levees have been overtopped and they have been raised several feet above the first height. The trouble was caused by vegetable growth and the deposition of silt in the waterway. During the summer season a heavy growth of weeds chokes the channel and checks the current during times of high water, allowing silt

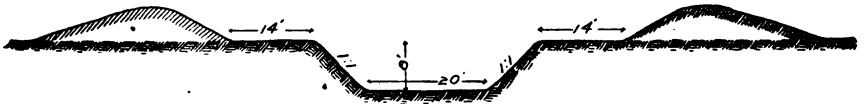

FIG. 117.—Section across Otter Creek showing dredged channel and spoil-bank levees.

to be deposited. During low-water periods the stream is spread over such a large surface that the channel will not keep clean, although there is a good fall.

At Otter Creek, on the Illinois River, a similar improvement was made, but instead of building cross levees 1,000 feet apart a deep channel was dredged from the river to the bluff, the waste material being deposited on either side in the form of levees (fig. 117). The excavated channel is of sufficient capacity to carry the ordinary floods at times of low water, while during the high-water season the spoil banks act as levees to hold the flood water in the channel. By reason of the narrow channel in which the water is confined it retains its velocity and thus carries the greater part of the silt through the channel. Whenever silt is deposited in the ditch under these conditions, it is removed as soon as the water in the river falls, as this produces an increased velocity in the channel of the ditch in which the water is concentrated.

During the past spring a break occurred in the Otter Creek levees, caused by the ice breaking in the creek before it did in the river, and a jam was formed near the lower end, causing the water to overtop the levees. Near the point where this break occurred an area of

approximately 20 acres was covered about 3 feet in depth with silt deposited by the water after it had escaped from the channel of the creek. So far experience shows that narrow, deep channels of not more than sufficient capacity to carry the floods of the watershed will clean out better than larger ones.

In some localities the hill water emerges from the highlands in numerous small streams, as in the Coal Creek district before described. These streams are difficult to control, as they come into the bottom with very rapid currents, heavily charged with sediment, which is deposited immediately upon the checking of the current. Where it is desired to prevent the hill water from entering the district it is necessary to unite these streams by an intercepting ditch running along the outer edge of the bottom until a point is reached where it can be carried to the river between cross levees. As the intercepting ditch is of lighter grade than the streams coming from the hills, it has less velocity, and as a result is rapidly filled with sediment, only a few days of flood water being necessary sometimes to entirely destroy its efficiency as a drainage channel. No satisfactory plan for preventing this has been devised.

In one class of closed districts, such as the Warsaw-Quincy, Flint Creek-Iowa River, and others in the Mississippi, where the bottoms are intercepted by old channels and sloughs, no effort is made to carry the hill water around the district, but it is permitted to run directly into the district, filling up the channels and sloughs, which act as reservoirs until the water in the river falls sufficiently for gravity drainage to take place. In all closed districts it is necessary to provide means for gravity drainage during low water, and this is accomplished by variously constructed outflow culverts, so arranged that they can be closed against the river water during the flood season and opened during the low-water season.

For this purpose both earthen and iron pipes are used. A few wooden sluices have been used, but on account of the short life of wood and its contraction and expansion when alternately wet and dried they have not been satisfactory. On the Flint Creek-Iowa River levee cast-iron water pipe 3 feet in diameter has been used. On the Warsaw-Quincy levee pipe 3 or 4 feet in diameter, made of boiler plates, has been exclusively used. A private levee on the Illinois River and also the South River levee near Hannibal, Mo., which are in process of construction, are using 36-inch vitrified sewer pipe, with one joint of cast-iron water pipe on the outer end, but neither of these culverts has yet been tested.

All the culverts examined showed the effect of settlement immediately under the levee, the weight of the levee having caused the culvert to settle faster in the center than at the ends. This settle-

ment has a tendency to distort and flatten some of the riveted pipes, while in the cast-iron pipes it springs the outer joint, causing them to leak. In several instances the flow of water through the outer joint has eroded away a great deal of the earth covering the culverts back of the abutment. In all cases where cast-iron pipes have been used for outflow culverts the outer end is protected by a masonry abutment and the inner end by masonry or riprap. Some of the steel-plate culverts have their ends protected by masonry, others by riprap or timber sheathing, while a few have no protection whatever.

There is as much variety in the form and construction of the valves which open and close the culverts as in the culverts themselves. In a few cases the valve is merely a heavy iron lid, made to fit the pipe, and fastened to its upper side by a hinge, and designed to open and close by

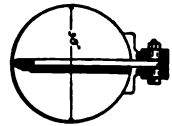
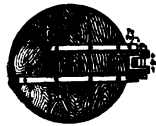
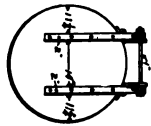
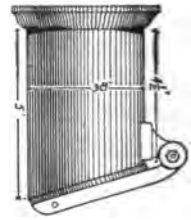
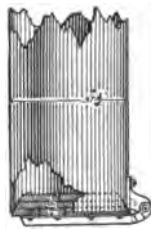
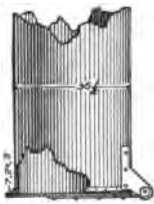

FIG. 118.—Sketch of valve for riveted-plate outflow culvert.

FIG. 119.—Sketch of wooden valve for outflow culvert.

FIG. 120.—Sketch of cast-iron valve for outflow culvert.

hand. Those for the outflow culvert at the Meredocia district are rectangular cast-iron valves, opened and closed by means of a capstan placed on a pier which is built on the outer abutment of the culvert. They are not satisfactory, from the fact that they require constant attention and are hard to manipulate. In the greater number of the districts attempts have been made to secure automatic valves. Where steel-plate culverts are used the valves are usually made of one-quarter inch plate, hinged to the upper side of the pipe by two strap hinges (fig. 118). The section of pipe which acts as the seat of the valve is sometimes cut at a slight angle and reinforced by a 2-inch angle iron bent around the pipe so as to fit along the edge. Both wooden and cast-iron valves are used on the cast-iron pipes. Wooden valves are made of three thicknesses of 2-inch plank cut in a circular form, the inside diameter being 6 inches smaller than the outside (fig. 119).



FIG. 1.—WOODEN OUTLET IN HARTWELL RANCH LEVEE.



FIG. 2.—OUTLET END OF OUTFLOW CULVERT IN FLINT CREEK-IOWA RIVER LEVEE, SHOWING WOODEN VALVES.



FIG. 3.—OUTLET END OF OUTFLOW CULVERT IN FLINT CREEK-IOWA RIVER LEVEE, SHOWING METHOD OF COUNTERBALANCING CAST-IRON VALVES.





This gives a bevel shape to the edge of the valve and permits it to close by the inner face fitting the inside of the pipe, while the outer face does not enter it. The valve is attached to the upper side of the pipe by a cast-iron hinge seat bolted to the pipe. The cast-iron valves are heavy plate, planed to fit the end of the pipe, which has been cut with a small angle and also planed, and is hung to the upper side of the pipe by a cast hinge (fig. 120).

The iron valves, being heavy, close easily, but require considerable head of water to open them. In a test on the Flint Creek-Iowa River culverts it required 12 inches of head to open the valve. This difficulty was obviated by counterbalancing the valve with an iron rail. (Pl. XII, fig. 3.) The wooden valves give good satisfaction, as they will open under a small head of water, but they are not easily kept in working order, as the alternate wetting and drying causes them to warp and twist until they do not fit properly. During the dry season they close, and then expand when wet until they will not open. They should be so constructed that they can not rise above a horizontal position.

There is no valve, regardless of its mechanism, that can be depended on to operate perfectly at all times. When it is closed drift and silt may lodge against it and prevent its opening, or when opened the drift and silt may lodge on the seat and prevent its closing. Hence it should be looked after and kept free from accumulations of this character. It should also be so constructed that if desired it can be locked either open or closed. In timbered districts drift is a continual source of annoyance at the outflow culverts, as it lodges in the valve or around the inlet, preventing the free flow of water. Where there is drift in the interior drainage channels the outflow culverts should be protected by screens made of timbers or wire cables, which will catch and hold the drift before it comes in contact with the inlet ends of the culverts.

In some of the low-lying bottoms the elevation of the general surface above that of low water is so slight that it is necessary to use pumps, and a number of districts have installed pumping plants. Pumps of the rotary pattern, like the Menge, and the horizontal centrifugal pumps are used. In the Lacey and Meredocia districts the discharge pipes are arranged as siphons, so that the actual lift of the pump is only the difference in elevation of the water on the two sides of the levee. In some districts the water is discharged from the pump directly through the levee, so that there is no loss of power due to lifting the water to an unnecessary height in order to discharge it over the levee. Some of the rotary pumps raise the water over the top of the levee regardless of the surface of the water on either side, while others have arrangements by which the water can be dis-

charged at various heights through the levee. Whatever the style of pump, a method of discharge should be adopted in which there would be as little waste of power as possible due to raising the water higher than necessary to give it a free escape on the outside of the levee. The pumping plant should be located at the natural drainage outlet of the district.

In a number of districts the results obtained from the first pumping plants have been disappointing, due partly to failure to provide for the volume of water that it is necessary to raise in order to drain the land inclosed and partly to failure to take into account the sources of the water that must be removed. In a closed district the water to be removed is storm water which actually falls on the area and seepage water which percolates through and under the levee. Where a district is not entirely inclosed by a levee the drainage from the high lands that comes through the district should also be provided for. Where drainage conditions are similar to those of Illinois, storm water can probably be removed by pumping plants having capacities of one-fourth inch in depth per acre every twenty-four hours. This is the experience along the Illinois River, but it should be noted that the amount of seepage to be removed may require considerable additional capacity in the pumping outfits.

Where closed districts are protected by well-constructed levees and all hill water taken care of outside the levee, it is believed that pumping plants can furnish efficient interior drainage at reasonable cost, but it is not practicable to remove hill water from a district by this method except for quite small areas. Where pumps are required they should be started in the spring as soon as water appears in the ditches and should keep the water down to the lowest limit until the flood season has passed. By so doing the soil will be thoroughly drained and it will serve as a reservoir during times of heavy rains or excessive flood heights of the river, thus preventing all injury to growing crops from oversaturation of the soil.

The cost of reclaiming a tract of land subject to overflow varies with its area and shape, a wide tract being cheaper proportionately than a narrow one, as the expense of the river levee is the same regardless of the width between the river and the bluff. The following tables give these costs in the various districts as nearly as it was possible to obtain them.

*Nature and cost of reclamation works in different districts.*

## PEKIN-LAMARSH DISTRICT.

Organized in 1889. Length of levee, including 1.5 miles of railway, 6.5 miles. Area protected, 2,500 acres.

Cost of levee .....	\$12, 500. 00
Paid railway company for use of grade.....	3, 200. 00
Cost of drainage system.....	7, 000. 00
Cost of pumping plant .....	3, 500. 00
General expenses.....	5, 800. 00
Average annual expenses.....	1, 200. 00

## Average operating expenses for 12-hour shift:

1 engineman .....	2. 00
Oil and waste.....	. 125
3.5 tons of coal (when river was at 15-foot stage).....	\$5. 77
2.5 tons of coal (when river was below 15-foot stage).....	4. 12
	<u>4. 95</u>

Average expense per 12-hour shift..... 7. 08

One year it was not necessary to run the pump; another year it ran only two weeks. In the remaining years it was operated through March, April, and May, but part of the time only twelve hours per day.

## LACEY DISTRICT.

Organized in 1897. Length of levee, including 2.5 miles of railway grade, 9.5 miles. Area protected, 5,180 acres.

Cost of levee .....	\$30, 000. 00
Cost of drainage system.....	11, 550. 00
Cost of pumping plant.....	12, 000. 00
General expenses.....	9, 950. 00
Cost of pumping after break of 1902.....	4, 000. 00
Cost of repairs after break of 1902.....	4, 000. 00
Cost of patrolling during flood of 1904.....	500. 00

## Average operating expenses for 12-hour shift:

Engineman .....	2. 00
Fireman.....	1. 75
Oil and waste.....	. 375
9 tons coal, at \$2.15 (when river is above 15-foot stage).....	\$19. 35
7 tons coal, at \$2.15 (when river is at 15-foot stage).....	15. 05
	<u>17. 20</u>

Average expense per 12-hour shift..... 21. 33

The cost of pumping has ranged from \$1,500 to \$5,000 per annum, the daily cost ranging from \$30 to \$45 per 24 hours. The pumps usually start the latter part of February and run until after the high-water period is over, in May or June. In 1901 the pump was operated only 20 days.

## COAL CREEK DISTRICT.

Organized in 1896. Length of levee, including 4 miles of railway grade, 10 miles, Area protected, 7,000 acres.

Clearing right of way, per acre.....	\$40. 00
Constructing levee with dredge, per yard.....	. 09
14 by 36 Corliss engine .....	1, 400. 00
Cartage and setting engine.....	600. 00
18 by 72 inch boiler, set.....	1, 500. 00
Condenser, set .....	400. 00
24-inch centrifugal pump .....	1, 050. 00
Cartage on pump.....	50. 00
Setting pump.....	100. 00
190 feet 26-inch riveted pipe with valve in place.....	1, 000. 00
Two 15-inch centrifugal pumps, at \$500.....	1, 000. 00
Cartage and setting pumps, at \$75.....	150. 00
Two 20-inch discharge pipes with valve (each pipe 290 feet long), at \$550.....	1, 100. 00
<hr/>	
Average operating expenses for 12-hour shift :	
Engineman .....	2. 00
Oil and waste .....	. 20
3 tons coal, at \$2.....	6. 00
<hr/>	
Average expense per 12-hour shift.....	8. 20
<hr/>	
Annual maintenance of pumping plant.....	50. 00

If the hill water were shut out of the district it is thought that the pump would drain it thoroughly with an average of four months pumping per annum, beginning in February and ending in June. It would be necessary to run two shifts only part of the time.

## MEREDOCIA DISTRICT.

Organized in 1897. Length of levee, 2.9 miles. Area protected, 8,335 acres.

River levee, at 8 cents per yard.....	\$7, 997. 20
Divide levee, at 7.5 cents per yard.....	1, 987. 50
Outflow culvert.....	3, 320. 14
Pumping plant.....	7, 096. 47
General expenses.....	3, 399. 10
Dredging ditches, at 8 cents per yard.....	8, 100. 32
<hr/>	
Annual operating expenses of pumping plant :	
For year ending July 1, 1900—	
Engineman .....	205. 00
Coal .....	514. 14
Repairs and small bills.....	74. 58
Insurance of plant.....	35. 00
<hr/>	
Total for 82 days of 12 hours.....	828. 72
<hr/>	
Average per day.....	10. 10
<hr/>	

## Annual operating expenses of pumping plant—Continued.

## For year ending July 1, 1901—

Engineman .....	\$352. 50
Coal .....	1, 319. 49
Repairs .....	99. 73
Oil and waste .....	38. 88
Kindling .....	9. 50
Insurance .....	35. 00
Total for 141 days of 12 hours.....	1, 855. 10
Average per day.....	13. 16

## For year ending July 1, 1902—

Engineman .....	160. 00
Coal .....	412. 58
Oil .....	5. 36
Repairs .....	47. 15
Insurance .....	35. 00
Total for 64 days of 12 hours.....	660. 09
Average per day.....	10. 31

## For year ending July 1, 1903—

Engineman .....	418. 00
Coal .....	1, 887. 72
Insurance .....	35. 00
Total for 167 days of 12 hours.....	2, 340. 72
Average per day.....	15. 21

## For year ending July 1, 1904—

Engineman .....	470. 00
Coal .....	2, 083. 24
Repairs and sundries.....	285. 00
Insurance .....	44. 00
Total for 188 days of 12 hours.....	2, 882. 24
Average per day.....	15. 32

## FLINT CREEK-IOWA RIVER LEVEE.

Built by United States Government and completed in 1900.  
Length of levee, 35.3 miles. Area protected, 44,722 acres.

Levee at 12.6 cents per yard.....	\$233, 963. 97
Superintendence and inspection.....	29, 555. 05
14,770 linear feet of levee revetment.....	5,457. 64
6,876 linear feet of shore protection.....	9, 645. 97
Outflow culverts.....	10, 618. 23
Right of way.....	444. 75
Surveys for final location.....	5, 794. 72

## WARSAW-QUINCY LEVEE.

This protects three districts. Original cost and maintenance does not include \$85,000 spent by the United States Government in strengthening the levee.

## Hunt district:

Organized in 1886. Length of levee, 16 miles.	
Area protected, 180,000 acres.	
Original cost of levee.....	\$102,387.45
Annual expense of maintenance.....	4,500.00
Estimated value of property destroyed in flood of 1903 .....	200,000.00
Cost of repairing break of 1903.....	8,762.00

## Lima Lake district:

Organized in 1886. Length of levee, 10 miles.	
Area protected, 14,000 acres.	
Original cost of levee.....	94,000.00
Annual expense of maintenance.....	3,125.00
Estimated value of property destroyed in flood of 1903 .....	210,000.00
Cost of repairing breaks of 1903.....	9,000.00

## Indian Grave district:

Organized in 1880. Length of levee, 21 miles.	
Area protected, 17,926 acres.	
Original cost of levee.....	178,000.00
Estimated value of property destroyed in flood of 1903.....	270,000.00
Cost of repairing breaks of 1903.....	10,000.00

Each of the above districts was flooded in 1892, 1895, and 1897, with a total estimated loss as great as that of 1903.

## SNY ISLAND LEVEE.

Organized in 1871. Length of levee, including 3 miles of railway grade, 52 miles. Area protected, 110,000 acres.

Original cost of levee.....	\$500,000
Estimated value of property destroyed in flood of 1876..	174,000
Estimated value of property destroyed in flood of 1880..	249,000
Estimated value of property destroyed in flood of 1881..	500,000
Estimated value of property destroyed in flood of 1888..	1,434,000
Amount expended for repairs prior to 1893.....	446,438
Expense of patrolling levee during flood of 1892.....	14,000
Estimated value of property destroyed in flood of 1903..	415,000
Cost to district of filling in crevasse of 1903.....	25,000

Where levee construction is comparatively new, the contract and specifications for the work as drawn often contain requirements which are unnecessarily exacting. Some require a large percentage to be added for shrinkage and the work to stand to grade for a number of days after completion, etc. Such specifications often prevent

responsible contractors from bidding on the work or lead them to bid so high that the contract is awarded to irresponsible and poorly equipped contractors who are not able to carry on the work in a satisfactory and efficient manner. It is better economy for a district to assume more risk and responsibility in the construction than to charge the contractor with all contingencies that may arise. The most economical work is done where the specifications are clear and explicit on all points and where risks and uncertainties which contractors must assume are reduced to a minimum. Ten per cent for shrinkage is usually ample to require of the contractor, and as soon as a given section is brought to grade it should be accepted and the contractor released from responsibility. Where settlement occurs it should be filled at district expense. The contractor could be required to put up any structure necessary to show that undue settlement was taking place and by which the amount could be determined. The contract and specifications should set forth clearly the amount and character of the work to be done, bids called for on each item, and the contract let to a responsible contractor who is fully equipped to execute the work.

It should be remembered that no class of work should be more thoroughly done than that required in reclaiming overflowed lands. One weakness in a levee system may cause an almost inestimable loss of crops and farm property as well as great injury to the works themselves. Levees can not be made a piece at a time or cheaply constructed with the intention of improving and strengthening them later without the risk of having the entire system destroyed before the contemplated improvements can be made. Consequently a reclamation project should be carefully planned and then rapidly executed in the most thorough manner.

#### **VALUE OF OVERFLOWED LANDS.**

These lands range in price from \$5 to \$60 per acre. The lower value is for land which floods every year and will furnish no valuable timber, the higher price being that at which owners hold improved high land which overflows only at times of extreme high water.

During the low-water years of the nineties large yields of corn and wheat were grown on such lands as were then reclaimed, which caused their price to advance to \$60 per acre. Had they been successfully protected during the floods of 1902, 1903, and 1904 the value of these lands would have been greatly increased, as uplands which are not as productive are now valued at \$125 to \$150 per acre. The following estimate, showing the financial side of the improvement of these lands, has been made by calculating the costs and profits of 1 acre



under the same conditions as have been found on a 160-acre farm in the Lacey district:

Estimated cost per acre:	
Original cost of land.....	\$5. 00
Clearing.....	15. 00
Buildings and improvements.....	10. 00
Levee assessment.....	14. 00
Additional assessment necessary to construct the levee sufficiently strong to withstand high water in the river.....	10. 00
Total cost.....	<u>54. 00</u>
Estimated annual expense per acre:	
Interest on total cost (\$54).....	3. 24
Taxes, insurance, and repairs.....	1. 00
Pumping tax.....	1. 00
Total annual expense.....	<u>5. 24</u>
Average annual rental.....	7. 50
Annual net profit.....	2. 26

The productive possibilities of these lands are now being appreciated and renewed interest is being taken in the work of their reclamation. The problems to deal with and the nature of the work necessary to be done are being better understood by landowners, so that more profitable results will doubtless be obtained in the future than have been realized in the past.

### FLORIDA EVERGLADES.

The Everglades of southern Florida are attracting attention by reason of their ability, under proper drainage and management, to produce vegetables for the northern winter market and subtropical fruits of acknowledged excellence. A reconnaissance of lands in the vicinity of Miami was made for the purpose of determining upon the feasibility of draining a small tract of everglade land for experimental use.

The part examined comprises a belt of land extending about 60 miles north and 25 miles south of the city of Miami and for various distances from the coast line toward the Everglades. The topography of the land near the coast and its relation to the Everglades which occupy the interior are interesting and important. The rise of the general surface from the coast line westward for a distance of 3 or 4 miles is 9 to 16 feet. From this westward across the Everglades the rate is about 0.3 foot per mile, as ascertained by two separate surveys made under the direction of the Florida East Coast Railway Company. The dividing line between the slopes toward the Gulf and the Atlantic is about 22 feet above tide and extends

south from near the center line of Lake Okeechobee. The belt of land 3 or 4 miles wide first mentioned may be regarded as a rim which prevents the ready flow of water from the Everglades southeasterly to the ocean. Numerous small streams extend from the edge of the glades proper through this rim and are the only natural facilities for draining the glades.

The rock found in this part of the State is the coral breccia, which crops out at the surface over the entire width of the rim and is covered with pine timber and palmetto, with the exception of small areas termed "hammocks," which are covered with hard-wood trees. Arms of the glade land 0.5 to 2 miles wide extend from the head end of these small streams back into the Everglades proper for a distance of 2 or 3 miles, bordered by pine woods, beyond which is the open expanse known as the Everglades. These lands are called "prairies" and are covered with saw grass. Two types are best known, the marl and the sand prairies. The soil varies in depth from 1 inch to several feet and in all cases rests upon a base of coral rock. In some instances the rock is known as "plate rock," which is apparently smooth and solid. In other cases the rock is filled with potholes, making an irregular base upon which the soil rests. In some portions of the northern part of the tract examined muck and peat lands are found in quite extended beds, but they usually thin out and pass into the prevailing marl formation.

A great deal of money has been expended in drainage works by the Florida East Coast Railway Company. The operations of this company so far have been directed toward opening and enlarging the natural streams for the purpose of lowering the water of the arms of the glades during the winter season, in order to facilitate the growing of winter vegetables. This drainage has also permitted some fruit growers owning small detached tracts of glade land to drain them that trees are now successfully grown.

The average annual rainfall of that portion of the State is about 63 inches. The so-called dry season or portion of the year in which there is the least rainfall occurs between the months of November and March, during which time the normal precipitation is about 11.5 inches, ranging from 1.5 to 2.5 inches per month. During this season portions of the prairie lands are planted to vegetables, principally tomatoes, which are more profitable for shipping to the northern market than others and when properly fertilized produce large crops. The remainder of the year these lands are frequently covered with water and are largely abandoned until the opening of the winter season, when they are again plowed and planted. -

None of the glade land proper, as far as examined, has been so drained as to be suitable for the growing of trees or of vegetables requiring the entire season, except openings which are sufficiently

high to be protected from the volume of water of the interior, and which, by reason of their more elevated situation, have been artificially drained.

There are some features of climate, soil, and geological structure peculiar to this section which have an important bearing upon the success of any reclamation project that may be considered. The soil, both the marl and the sand, lacks those natural elements of fertility commonly found in other low-lying lands, and requires the liberal use of artificial fertilizers to produce either fruits or vegetables. The soil-water table may be 8 to 20 inches from the surface without injuring the growth of fruit trees, and it is observed that plants usually are not as sensitive to a saturated condition of the soil as they are in colder latitudes, where clay is a leading element in the composition of the soil.

The porous and absorbent nature of the coral rock has an important effect upon the water problems of the country. It is known that cavities exist in the rock at various depths, as shown by drilled wells, which occasionally penetrate reservoirs of water 4 to 6 feet in depth. It is also noted by truck farmers occupying cleared land near the coast that water comes upon their fields in some cases from the underlying rock when the water of the glades is at high stages. It is quite probable that this open and irregular structure is more strongly characteristic of the rim or coast belt than of land nearer the glades, since as we approach the latter the plate or solid rock seems to predominate. This point, however, has not been demonstrated and is one of the undetermined factors entering into the drainage of this portion of the Everglades.

The channels of the streams which now form the overflow outlets of the interior prairies disappear at the outer border of this vast expanse at an elevation of 9 to 13 feet above tide. As a result of surveys made across the glade, as before stated, it is reported that they have a slope of 0.3 foot per mile in a southeasterly direction. Should these streams be deepened, enlarged, and extended through the prairies, a grade of 0.4 foot per mile might possibly be obtained for the channels, part of which would necessarily be excavated through the rock.

In case only one channel should be made, it would tap the waters of the entire area at flood time, but would afford no more than flood relief, even if the canal were fully ample to carry the water of the entire area, for the reason that this expanse is practically level, and the water will not flow to this channel rapidly enough to give good drainage. This makes it necessary to dredge all of the natural streams into or through the glades as far as the divide between the eastern and western slopes, which is reported to be 22 feet above tide and to lie in a line extending south from the center of Lake

Okeechobee. For the reasons above mentioned, all of this work must be done before this area of approximately 3,500 square miles can be drained sufficiently for summer culture.

The practicability of draining small tracts about the border of the glades has been demonstrated only for the production of winter vegetables. While these areas may be somewhat increased and the risk of winter flooding diminished by the improvement of natural channels, it will be impossible to extend the area of these lands for fruit growing or make the glades more than temporary winter fields until more effective drainage is provided. The problem which confronts the investor and cultivator is not so much the possibility of draining the tract as a whole as what may be done in this direction within the limit of individual means to fit portions of this land for the production of crops.

Investigation of this portion of the glades was made with the view of ascertaining whether some plan might not be devised for reclaiming small areas. An experimental plan for determining whether portions of the marl land could not be inclosed by dikes to protect them from outside water and the interior be kept dry by pumping was proposed and a tract selected for the experiment, but it has not yet been put in operation.

The success of this method of drainage will depend upon whether a good dike can be made of the marl soil and also whether the head of water back of the dike may not force water through the underlying porous tracts into the inclosed area in greater quantities than can be profitably removed. The plan merits a trial. Such a method of improvement would admit of gradually pushing the drainage of the glades away from the higher rock lands, leaving an overflowed space of sufficient width to allow for the passage of the interior water. The dikes would be 4 feet high, and the total lift of water about 6 feet.

The economic advisability of such work will depend upon the value of the product. The prestige of Florida fruit in the market is encouraging and indicates that the State may easily lead in the quality of many of her fruits. The value of fruit products during the last two years, as reliably reported, has been \$200 to \$1,000 per acre, which amount would justify considerable expenditure for reclamation improvements. The expense of preparing the rock land for trees is not less than \$100 per acre, while the reclamation by levees, if such were found practicable, will not be more than \$50 per acre, though there would be a continuous expense for maintenance. Shallow drainage channels should accompany the levee system to provide relief from flood water from the glades and to carry off the water pumped from the land inclosed by levees.

A combination of the two plans will admit of the gradual development of the glade lands as the demand for their products increases.

### WISCONSIN MARSH LANDS.

It is estimated that there are 300,000 acres of marsh land in Wisconsin which at present have little or no value. Much of it is muck or peat derived from the sphagnum moss, and constitutes a class of land somewhat different from swamps found elsewhere, some of which have been drained and converted into productive farms. At the request of parties interested in the improvement of 32,000 acres of this marsh land lying in Marathon, Wood, and Portage counties, and organized under the name of the Dancy drainage district, this Office made a preliminary examination of the general characteristics of the project, and also of two similar ones in counties adjoining. A portion of the report submitted to the district is here given, which embodies such deductions and suggestions as seem justified by examinations so far made.

The purpose of drainage, aside from its benefit to the general health, is to prepare the land ultimately for the production of profitable crops. Therefore it is quite essential that a tract of land be drained with reference to its subsequent use.

The drainage and management of peat lands have occupied the attention of agriculturists and engineers in England, Scotland, Sweden, and other European countries for at least one hundred years. In these countries they are found in areas of considerable extent. While the origin and composition of moss lands in different localities vary widely, their general characteristics with respect to drainage are quite similar. In the first place, moss-peat lands have in many instances not responded to the ordinary methods of drainage. The secretary of the Orebro Agricultural Society of Sweden, in referring to this matter, says that there has been more money wasted upon the drainage of these lands than upon any other improvement attempted. It was not until a new system of drainage was devised by Joseph Elkington, of England, and put into practice in Sweden by George Stephens, an English engineer, that these lands were successfully drained.

The practice of one hundred years ago in the treatment of these lands should not be disregarded at this time, since the methods then used with success may be now applied when the character of the land and conditions are similar. The methods of drainage used by Elkington, Smith, Stephens, and many other English engineers were for a period of fifty years or more found eminently successful where other methods had failed. The following is a brief description of them:

The water which supplied the marshes was in almost every case found to have its source in outlying sandy or porous land occupying

higher elevations. The water flowed directly through this permeable layer into the lowlands, thus forming the bogs. The rainfall upon the bog land direct was an insignificant matter compared with the outside feeders which supplied such land. The rainfall itself was not sufficient to produce the moss growth which characterized the land. These beds of peat were often 20 to 30 feet deep, lying upon clay or sandy bottoms. Attempts to drain the lands by numerous parallel ditches of ordinary depths proved futile, although no expense was spared. It was found that the proper method was to intercept and cut off the supply of water coming from the higher levels. This was done by means of deep ditches located along the borders of the marshes and placed at the bottom of the peat formation wherever possible. Where it was not possible to reach the bottom of the peat the ditches were supplemented by wells, which were sunk below the bottom of the drains into the water-bearing material below the bed of the marsh. These wells offered free flow to the water beneath, which, impelled by the head furnished by the higher lands, rose to the level of the drains and passed away. Other ditches were constructed at somewhat wide intervals through the interior of the marsh for the purpose of receiving the storm water which it was necessary to remove, and also to intercept any bottom water that might pass under the outer drains. In case these wells failed to cut off the "bottom water," as it was called, wells were sunk at various points, as before described. Interior shallow surface ditches were added to remove heavy rainfall, and especially the water from melting snows which could not pass through the soil with sufficient freedom to leave the surface dry.

The history of this work, especially in Sweden, as given by Mr. Stephens in his book called "The Practical Irrigator," published in 1854, is instructive and suggestive to anyone engaged in the treatment of peat lands. The various accounts given in the proceedings of the Royal Agricultural Society of England and of the Highland Agricultural Society of Scotland, which include prize papers upon the reclamation of marsh lands, form a valuable compendium of early practice and indicate that the subject was regarded as of great importance to English and Scottish farmers. We find, however, something of a reaction in later practice from the fact that while the zeal of the early drainers was entirely exercised in making the land dry, it was soon found that its subsequent moisture content was a matter of no little importance. Mr. James Anderson, a noted agricultural writer, in his treatise on peat moss refers to the fact that in many cases the lands had become too dry, and in order to make them productive water should be in some way artificially provided. This is very strikingly set forth in the following quotation, which is given

because it apparently represents the close observation and wide experience of a practical man :

Moss, when thus reduced to a dead state to a sufficient depth, is in little danger of ever being too damp, unless the main drains are choked up so as to force the water to rise very near to or above the surface. Indeed, if no manure be given to it, moss is never extremely productive either of grass or corn (grain) unless it be kept moderately moist at all times. The soil is of itself so light that when dry it ceases to give nourishment to any useful plant whatever. Such dry moss spontaneously produces little else than the narrow-leaved sorrel (*Rumex acetosella*), and if plowed and sown with oats, though the corn (grain) may spring up and appear healthy enough for some time, yet when it gets into ear it becomes weak and soft in the stalk and falls over and withers before there be the smallest mark of a kernel in the grain. This disease is well known in all moss countries, and as it was originally believed to be occasioned by witchcraft, the name still remains, and it is called witched corn (grain). If, on the contrary, the land be laid flat and it be kept moderately moist without being wet, it produces luxuriant crops of excellent corn (grain) and grass, which, under proper management, it may be made to afford alternately forever without any manure whatever. This I myself have experienced for more than twenty years together, so that I reckon it one of the most profitable soils, where water can be commanded and duly regulated, that can anywhere be found.

But where the moss lies high, and no water can be commanded (very little will do), some kinds of manure are required to render this a very productive soil. Of all the manures that have ever been tried upon moss, no one can be compared to calcareous matter, under whatever denomination it may be applied, whether lime, marl, chalk, or shell sand.

No bottom is better for a mossy soil than quick moss, and if there be about 2 feet deep of dead moss, which in future I shall call moss earth, above it, it will admit of being properly managed either for grass or corn (grain) at all times; for the moss earth, acting as a sponge, allows the water during severe rains to sink slowly through it to the surface of the quick moss, so as never to render it, then, too wet. And when the plants are established upon it in the spring, these by their roots and leaves attract moisture both from above and below, so as to keep the surface mold in a due state for promoting vegetation. Even during the greatest droughts in summer the moss earth which lies next to the quick moss is kept perpetually moist, so that the roots which penetrate down to it find always abundant moisture to keep the surface mold in a proper state for promoting vegetation.

But that this effect may be fully felt, the surface of a mossy soil should be laid perfectly flat and as smooth and even as possible. It should on no account be laid up into ridges, but should be plowed into broad lands, without any open furrows at all, or with as few as may be. As the whole moss earth for 2 feet deep is, in fact, one continued covered drain, not one drop of hurtful water can be allowed to remain upon the surface, but sinks directly down till it reaches the quick moss, from whence it readily will find its way to the main drain if the initiatory operations shall have been properly conducted.

From these considerations, perhaps no soil can be made so proper for being converted into watered meadows as moss. Superabundant moisture can be drained from moss land when thus managed perhaps more quickly and more thoroughly than from any other soil, and this is a circumstance that has been found to be highly favorable to watered meadows. The only difficulty in this case for pasture land is the softness of the surface of the moss.

When the situation is dry a narrow border of quick moss should be left untouched all round the field, through which the small drains going into the main drain should pass; and in this place the drains ought to be left uncovered, so as to admit of being stopped up at pleasure with a little quick moss. They ought thus to be stopped immediately after sowing corn (grain) and the water to be let off occasionally only as circumstances might indicate.<sup>a</sup>

It was later found that no soils respond more readily to irrigation than these peat lands after drainage. Their use in what were termed "water meadows" has existed to the present time, resulting in the production of large crops of hay and pasture grasses. The matter is strikingly set forth in an old work, called "Smith on Water Meadows, Draining Peat Bogs, and Other Improvements," from which the following quotation is taken:

All live peat bogs are composed of vegetable substances which abound with seeds or roots of many aqueous grasses, forming land which is fit for irrigation wherever the degree of moisture can be appropriated. But if the peat be entirely deprived of all moisture and left exposed to the summer sun it is then little better than a barren substance. The plants on the surface, being totally deprived of their former subsistence, cease to grow, and the vegetable matter (for in this case there is little or no soil) being unfit for the support of plants suited to dry land, the most perfect sterility must be the consequence. It is well known that peat once dried will not readily receive moisture again, and this may serve to account for the uncommon sterility of some peat bogs which I have seen plowed up after drainage.

Though these works are all old, they give experiences which are extremely valuable, and in the light of later investigations suggest methods of handling the peat lands with which we now have to deal in this country. Some attention has already been given to the subject in this country, though it may be said that the use of peat for fuel and land fertilizing has formed the principal subject of investigations.

About fifty years ago Prof. S. W. Johnson, of Yale University, took up the investigation of peat with reference to its value as a fertilizer, and for the purpose of obtaining information regarding the location, peculiarities, and condition of peat beds issued a circular containing questions arranged to secure such information. The answers to this circular are instructive in considering the question of the use of these lands for producing crops, since in many cases the landowners described the drainage and the kind and yield of crops produced. From these answers it appears that the land had proven profitable in all cases for the production of hay, and in many cases for cabbage, onions, celery, and some other garden crops.

Coming down to more recent times, we find that the matter has received attention from the Pennsylvania State Experiment Station, and that a report was issued in 1895 entitled "Some Pennsylvania

---

<sup>a</sup>A Practical Treatise on Peat Moss, 1794, pp. 99 et seq.



Peats.”<sup>6</sup> In this report analyses of samples from different parts of the State are given and the samples are discussed with reference to their value as fertilizers. The cultivation of peat beds is referred to, and we quote the following paragraph relating to that phase of the subject:

To accomplish the transformation of peat into a substance readily available for plant food two or three very simple operations are sufficient: First, the peat must be thoroughly aired, as a consequence of which the poisonous lower oxids of iron and sulphids will be reconverted into valuable plant foods. Second, if there is a deficiency of mineral matter, especially lime, the latter must be added; the acidity of the organic matter is thus neutralized, the helpful bacteria come in and soon begin the conversion of the inert nitrogen into ammonium compounds and salts of nitric acid capable of sustaining the most vigorous crop development if other essential food materials be at the command of the plant.

Bulletin No. 95 of the Indiana State Agricultural Experiment Station, published in 1903, treats of the unproductive black soils found in that State. Instances are cited in which the drainage of these lands, which are of a peaty nature, has failed, to which fact is attributed much of the difficulty in making them productive. Drainage was attempted by the ordinary method of laying parallel lines of tile through the bog. Upon examination, water was found to stand 6 or more inches above the tile. The failure of the tile to lower this water table is explained in the bulletin upon the theory that the water would not readily enter the tile when laid in muck land. The true explanation, derived from descriptions of the conditions given in the report, is that the upward pressure of the water by reason of the head derived from outside the bog is greater than the weight of water above the tile. It is stated as a conclusion from many of the investigations made that the permanent improvement of such lands demands efficient drainage and that this drainage should usually be of a special character. It is further advised that before making any outlay for the permanent improvement of such lands a preliminary drainage survey should be made and the system of improvement should be based upon the results of such survey.

The improvement of peat and muck swamp lands in Illinois is the subject of Bulletin No. 93 of the experiment station of that State. It deals principally with fertility problems. It is concluded, however, that before any system of improvement can be successful the soils must be well drained. The soils mentioned, however, are of different origin from those known as moss peats. They may properly be called grass peats, which, though similar in structure and the way in which they are affected by drainage, are different in chemical composition. In that State they are found resting upon clay, some-

---

<sup>6</sup> Pennsylvania Sta. Rpt. 1895, pp. 148-156.

times upon sand. The treatment of muck lands upon a clay foundation is more simple as far as the fertility problems are concerned, from the fact that the clay subsoil, when mixed with the muck material, has a marked effect on its productiveness. An instance of this kind is cited in the treatment of the soil in the Vermilion swamp, in Ford County, in which the plowing of the soil sufficiently deep to bring some of the clay subsoil to the surface converted a comparatively unproductive soil into one which produced 60 bushels of corn to the acre.<sup>a</sup>

In looking over the history of this matter it seems that work pertaining to the reclamation of peat lands has not been done in such a way as to derive definite conclusions concerning their productiveness. The efforts of those who have had charge of drainage have been directed toward drying the lands, while those who have investigated with reference to their fertility or use for fuel have examined them with reference to these points alone. In the bulletins referred to efforts have been directed toward ascertaining the fertility of these lands from the standpoint of the chemist. The value of free water or of moisture conditions in these soils as elements of their productiveness does not seem to have been made the subject of experiment. We learn from the experience of engineers with moss lands in England and Sweden that they can be made too dry, in which state they are as valueless for production as when too wet. The remarkable yields of grasses reported from these drained lands after being irrigated show that their proper water content is of vital importance in their productiveness. It is quite possible that this feature has been lost sight of in later investigations, yet it is admitted by all capable of giving an opinion upon the subject that these lands must be well drained before they can be fitted for the production of land instead of water plants.

It is also noted, in a study of these marshes in various countries, that they are as frequently found resting upon sand as upon clay, and that there appears to be no material difference in the structure of the two or in their value after reclamation. Those underlaid with clay are more difficult to drain, since the water must be taken from the moss itself by means of frequent and deeply laid underdrains. The clay bottom aids in retaining needed moisture and, where it can be reached in the cultivation, forms an excellent material for mixing with the peat, supplying in a measure, as it is claimed, the potash frequently wanting in these lands.

Through some inquiries instituted by the writer during the season of 1901 it was learned that the turf lands in the valley of the Kankakee River in Indiana, which had been drained, suffered more from drought than ordinary loam lands. Mr. E. M. Pike, of Chenoa, Ill.,

---

<sup>a</sup> Illinois Sta. Bul. 93, p. 293.

who has had eight years' experience with a tract of land in the Kankakee Valley, near South Bend, Ind., describes the soil as a grass turf resting upon a clay bottom. After tile-draining the land with lines 20 rods apart he burned the turf, which was 13 inches thick, and in the fall sowed timothy grass directly upon the surface without further preparation. He raised a crop of excellent timothy hay the following season, 300 acres giving him 400 tons of hay. He has since supplemented the first drainage by placing a line of tile between those first laid, making the drains now 10 rods apart. He has also found it necessary to place them not less than 4 feet deep, as the soil, which is about 4 feet thick, settles one-half. In his eight years' experience he finds that the turf is gradually becoming more compact and forming what he thinks will eventually prove a first-class corn soil, though up to the present time it has not produced that crop successfully. The clay at the bottom gives a continuous supply of moisture, which, when the soil has reached its final condition, will, he thinks, make it exempt from the effects of drought. He expresses the opinion that it would be better, if possible, to pasture these lands for a term of years, until they become fully settled and the wild grasses have been completely destroyed. He has raised potatoes and all kinds of vegetables with success, and continues to get about 1.25 tons of hay per acre from his meadow land.

In Bulletin No. 80 of the Wisconsin State Experiment Station, issued in 1900, Professor King describes a large number of laboratory experiments made for the purpose of determining the fertility of the Wisconsin swamp lands. His experiments show that the application of lime does not produce any improvement. One of his experiments was made to determine whether the difficulty with these soils might not arise from the presence of soluble salts which might be washed out. After passing 42 inches of water through a sample of soil it was learned from a culture test that its fertility had been decreased in a marked degree, showing that excessive washing of the soil and removal of the drainage water produced an injurious rather than a beneficial effect upon the productiveness of the soil.

The experience of Mr. Ingraham, of Babcock, Wis., as well as of other farmers, indicates that these lands will grow tame grasses in great luxuriance under favorable conditions. Onions and cabbage of good quality and in large quantities have been grown, but the land thus far cultivated for these purposes seems unaccountably fickle in its behavior, and the factors controlling its peculiar productive properties are not yet understood.

With these preliminary notes, we may now take up the discussion of the problems to be considered in the drainage of the 32,000 acres of land included in the Dancy drainage district. While there may be

some clay and loam soil bordering the stream and at the lower parts of Bear and Howe creeks, we may regard the entire area as a moss peat or muck swamp resting upon a sand bottom, the thickness of the vegetable formation being 4 to 5 feet. The survey shows that the basin included in this district receives the drainage of 122,520 acres of outside land. The light fall of the main stream—less than 6 inches per mile—and the modifications made in its channel to fit it for slack-water log floating produce conditions most favorable to the permanence of the swamp. The Weather Bureau records show that the annual precipitation is about 32 inches, reasonably well distributed. The large snowfall and consequent spring run-off produce floods which do not depend for their volume upon the immediate precipitation, but often upon local conditions of temperature, which require that the main drainage ditch have ample capacity. The main channels shown on the engineer's plans are designed to remove one-fourth inch in depth of water in twenty-four hours from their respective watersheds. These are none too large for the work which will be required of them during the spring months. Under the conditions of a northern climate the run-off will be as great from peat and muck lands as from surfaces of any other character. The quantity to be removed during the growing season, however, will be greatly modified by absorption and the peculiar physical structure of the soil. It is expected that the drainage of the entire area will be accomplished by lowering the water table of the sand sufficiently to permit the surplus water contained in the muck to pass directly downward into the sand, the latter, when drained, affording the best possible underdrainage to the muck.

The facility with which water may be expected to pass laterally through the sand to the ditches is somewhat problematical, but from observations made in other localities it is probable that ditches 3 feet in the sand will afford reasonably free drainage for land one-half mile distant. The extension of the lateral system farther than is now indicated in the plan is not advised, except in one respect, and that is this: It will be found that the supply of underground water will seep into the basin at the base of all the ridges and will keep the muck wet, which condition the interior ditches will not materially relieve. An intercepting ditch constructed parallel with the bases of the ridges and connecting with the most convenient laterals or with the main channels will probably be required. It may not be practicable in every case to excavate intercepting ditches sufficiently deep to reach the sand, in which cases they may be supplemented by box-curbed wells at various points, their location being governed by the contour and slope of the outlying land. These wells should be sunk 3 to 4 feet into the sand and be connected with the ditches

at their grade lines. This method has proven successful in the West in relieving land of seep and spring water resulting from irrigation at higher levels, and is practically the same method at one time used in Europe and described in the preceding pages.

Another addition to the plans of the engineer may in time be found necessary. While the removal of the floods of spring and possible heavy downpours by means of the large ditches and by underdraining the land, which can be accomplished through the medium of the bottom sand, will be necessary, it may be just as important to subirrigate the muck land by holding back the water contained in the sand so that it may be kept in contact with and feed the muck soil during the summer season. When we drain soils containing loam and clay we rely upon the power of such soils to retain capillary moisture in sufficient quantities to feed vegetation when the moisture from rainfall direct is insufficient. The lands under consideration lack this property and must rely for their supply upon the free water carried by the sand. The complete removal of the surplus water at first will permit air, heat, and frost to ameliorate the raw condition of the partially decayed vegetation, but later the soil must be kept constantly moist, especially in its lower horizon, in order that the process may be continued and that the plants may have sufficient moisture. That is, the soil should always be dry on top but moist below. Much more water is required to secure this condition in turf soils than in loams or clays. To regulate this moisture supply, it is suggested that all of the lateral ditches be provided with adjustable gates or dams by means of which the flow may be retarded or stopped and the water raised or lowered at the will of the cultivator until the required state of moisture is obtained. It is probable that no such devices will be required in the large main channel or two creek ditches, but may be in all of the others. In this connection it should be observed that it is difficult to drain some muck soils in certain stages of their decomposition, as they retain water against gravity with great tenacity, but the ability to regulate the level of the water table will be desirable in the management of the lighter forms of turf.

Keeping in mind the results of examinations thus far made and information gathered from various sources concerning drainage and management of turf lands, the following condensed outline of procedure for their reclamation is suggested:

- (1) Construct the system as represented upon the engineer's plans, adding the intercepting drains bordering the marshes, where thought necessary, in the manner previously described. The lateral ditches should reach not less than 2.5 feet into the sand. All ditches should have their waste banks deposited in such a way that a clear berm of 10 feet will be secured.

(2) At the end of the first year after completion of the ditch system make provision for regulating the water in the lateral ditches during the summer, as suggested.

(3) Provide shallow field ditches to lead spring flood water into the lateral district ditches.

(4) Remove the moss turf by burning when the land contains such an amount of moisture that the burning process will not reach deeper than desired, after which sow the grass.

(5) In all subsequent management give careful attention to moisture conditions, as it is believed that this is important in getting crops from these lands. Subsequent treatment with both farm and commercial fertilizers may be found valuable, and experiments should be made with them, but the efficiency of nature's ordinary means of soil improvement should be tried first, for they will in any event be required as a preliminary to any more complete treatment.

It is generally conceded that lands of this character will settle 50 per cent after the moss or top turf has been removed. This will take place gradually as the turf becomes changed into muck, so that the space between the surface of the ground and the bottom sand will diminish from year to year until the muck soil assumes a practically stable condition. This suggests that the quantity of soil water required may be decreased as the process of decay and consequent settling of the turf goes on.

There may be differences in the mechanical make-up and chemical character of several of the swamp tracts in Marathon, Wood, and Portage counties, but where they are underlain with sand the drainage treatment of each should be similar, with possibly the exception of a few details. By reference to the geology of the State it is seen that the section covered by the Dancy marsh was not glaciated. It belongs to that area found in the middle of the glacial drift of the State which for some cause, variously explained by geologists, was passed around by the lobes of the glaciers which moved southwesterly over the State and was left like an island in a sea of ice. The prevailing rock is granite, from which the sand underneath the marsh appears to have been derived. It is possible that this sand, when exposed to the weather in the form of a top dressing for the muck, may become valuable as a fertilizer by reason of the feldspar it contains. The question whether or not feldspar has been dissolved by the water in which it has lain so long has a direct bearing upon its value in this respect and merits investigation.

It may be here observed that the amount of moisture required by different soils for maximum crop production has not received such attention from investigators as the importance of the subject deserves. It is known that a sandy soil containing 8 per cent of moisture will often produce good vegetable growth, while a clay loam requires

20 to 27 per cent of moisture to produce the best results. Some soils apparently moist will not readily give up their water content to plants. Peat and muck soils have a large capacity for water, yet some of them, owing to their open structure, yield it up rapidly when exposed to dry atmospheric conditions, while others retain it with great tenacity. The conversion of peat formations into muck, their succeeding stage, is accomplished most rapidly through the agencies of air, heat, and moisture. They must be deprived of such water as will flow by gravity, yet, by reason of the open nature of the material, capillary water will be most rapidly removed by air, which will fill every space not otherwise occupied. For this reason large evaporation takes place, producing a low temperature in such soils until they become covered with a coat of well decomposed and finely divided soil. Special investigations along this line would be of great service to those who contemplate the reclamation of peat marshes. Drainage and fertility are coordinate problems, which should be investigated in the field as well as in the laboratory, the solution of which will have an important bearing upon the reclamation and development of the Wisconsin marshes.

#### HILLSIDE EROSION OF FARM LANDS.

The surface washing of hillsides in the Southern States results in great loss to farmers by depleting the fertility of the cultivated land, not infrequently causing the abandonment of entire fields to briars and broom grass. The terrace system which is commonly employed to prevent washing consists of a series of small ridges constructed across the slope on contour lines at intervals the width of which depends upon the degree of the surface slope. These ridges are sometimes placed as close together as 20 feet. As the ridges are at least 4 feet in width, 16 per cent of the land is thus occupied. It is not uncommon to find entire fields terraced at 100-foot intervals, in which cases 4 per cent of the land is occupied by the ridges. The object of their construction is to retain the rainfall until it can pass into the soil by slow percolation. In some cases the trench on the upper side of the terrace is given a gentle grade for the purpose of leading the water to some point where it can be taken to the stream at the foot of the slope. The ridges serve as a series of small dams which, when they break, as they frequently do, cause the water to wash away considerable soil, and break one or more of the terraces below. Such breaks often open out washes during a single rainstorm, which are costly to repair and which, if neglected, seriously injure the field. The permeability of hill-land soil to water varies greatly, as does the slope and contour of the surface. Farmers usually vary but little their practice of terracing, applying the same system of construction to all hill lands.

From some studies of the different situations and close observations upon the behavior of terraced hills it is believed that there is much room for the exercise of skill in adapting various means to their improvement. It is desirable to conserve a good portion of the rainfall in the subsoil, and to accomplish this its removal should be as slow as practicable. A special effort should be directed toward preventing its concentration in depressions which are found on the hillsides, as this causes gullies to be formed, which will increase in size and destructiveness with every considerable rainfall.

An improvement in the laying out of terraces is suggested and practiced by Hon. L. G. Hardman on his farms in Jackson County, Ga. Instead of a ridge or dike being made for the retention of the surface water, the terrace is made level and seeded to meadow grass, which is

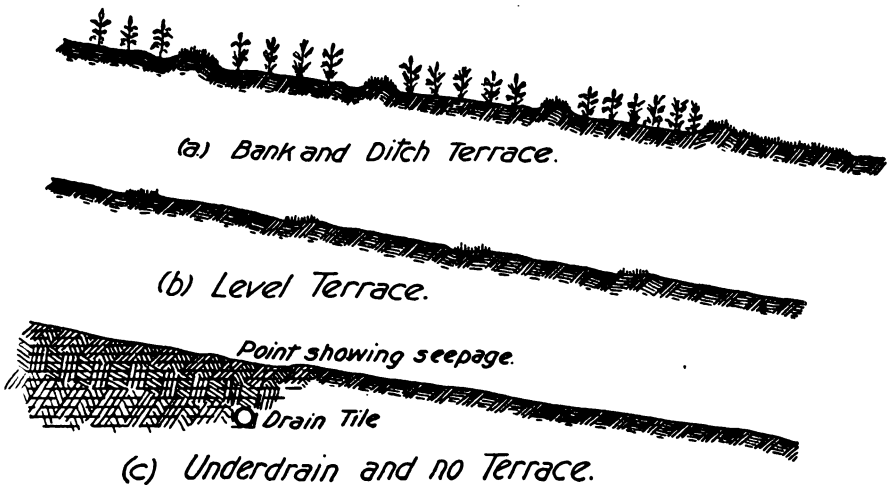

FIG. 121.—Method of protecting cultivated hillsides from erosion.

mowed for hay each season. The effect of a terrace of this kind is to check the flow of water and cause such part of it as is not absorbed by the soil to pass to the next tier of land without concentration. The growing grass in summer and its stubble in winter serve to arrest the soil matter suspended in the water. The location of such terraces may be easily changed, so that land at one time occupied by a terrace may subsequently be cultivated.

It was noted in the report of drainage investigations for 1903<sup>a</sup> that an experiment was made on hillside land in Jackson County, Ga., to test the efficiency of tile drains for preventing the erosion of the land, and thus doing away with terraces altogether. These drains have been in operation two years. Two crops have been produced and the land is now seeded to the third. A portion of a field having an

<sup>a</sup> Office of Experiment Stations Bul. 147.



average slope of one foot in ten, which had been abandoned because of excessive erosion, was selected, and drain lines were laid out and the drains constructed in the spring of 1903 according to the plan shown in figures 121 and 122. The soil is red sandy loam of good depth, with firm clay subsoil containing scattering gravel stones. It is much more permeable to water than hills made up of light-colored

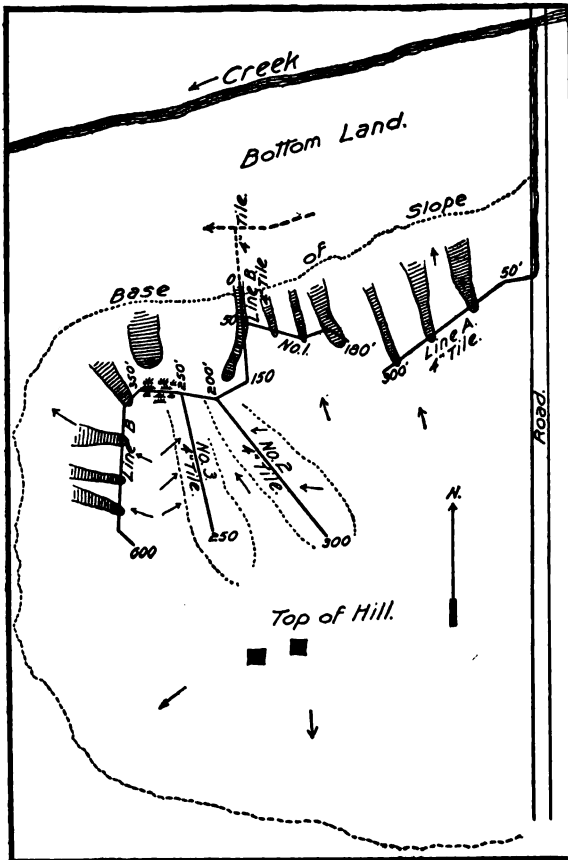

FIG. 122.—Plan of underdrains for Georgia hillside experiment.

clay material, which condition is favorable to treatment by underdrainage. It had been observed that seepage water appeared in small quantities at points part way down the slope, causing the earth to soften and readily yield to the eroding action of surface water as it flowed down the hill. Ditches soon resulted, which gathered the water in greater quantities than could be controlled by the ordinary methods employed. In the experiment described underdrains were placed at points where seepage water appeared to intercept the water of percolation and thus preserve the firmness of the surface soil. The drains do not conduct all the water away from the land, but permit an outflow through the joints of the drains into the subsoil in case it has sufficient porosity to receive it. The drains thus assist not only in arresting the surface water, but distribute and conserve it in the subsoil. To accomplish this end it is desirable to lay the drains on a comparatively light grade, though that must be largely dependent upon the contour of the land treated.

The cost of the improvement under this experiment was \$10 an acre for the land regained. The high price of drain tile, 4-inch

costing \$41 per 1,000 feet, made the work more expensive than similar drainage should be ordinarily. The gross receipts of either of the two crops produced from the land previously abandoned would pay the cost of the improvement.

It is here suggested that underdrains judiciously located in such soils or the use of level terraces where the former plan can not be readily employed greatly facilitate the cultivation of hill lands and increase the crop area of each field so treated. Four to 16 per cent of the land can often be saved for cropping purposes, besides the annual expense of cutting the briars and grass which grow luxuriantly on the terrace lines. The level system permits the terraces to be used for hay and the product will fully pay for their care. It is not here urged that terraces may be abolished, but that underdrains may frequently be employed in lieu of them, that they will conserve the moisture of hill soil, and at the same time prevent the formation of surface washes. When abandoned hillside land can be restored to producing fields at a cost of \$7 to \$10 an acre, it is an improvement that will commend itself to the owners of such fields. Too great care can not be taken to adapt such improvements to the soil and surface slopes. Subsequent cultivation should as far as possible fill up ditches and depressions that would serve to collect the surface flow.

#### **INDIANA TILE DRAINAGE.**

For the purpose of ascertaining the process by which the tile drainage of many farms in the upper Wabash Valley has been developed, a few farms in Madison, Miami, Howard, and Tipton counties have been examined, and such information as could be obtained is herewith given. Some of the details were collected by local surveyors who were familiar with drainage methods and were in some instances supplemented by the visits of our regular field assistant. As might be expected, much of the work described has been done in a haphazard manner, yet along lines which have in the end secured fairly satisfactory results.

#### **MADISON COUNTY.**

The swamp lands of this county, when first occupied, had little value except for the fine growth of timber which covered them. The first occupants began to drain them by removing the undergrowth, fallen trees, and other obstacles which were found along the natural depressions, thus obtaining some relief from overflow. In subsequent work it was not uncommon for the settler to use a small section of a tree from which the heavy limbs had been removed to within 6 or 8 inches of the main trunk and, attaching a team, drag it through the opening previously cleared, and so deepen and enlarge the drainage course. These channels were afterwards gradually deepened and

widened, ranging from 4 to 6 feet in depth and 12 to 20 feet wide on top, and eventually became the main outlets for drainage systems.

Underdrainage was begun and carried out along the lines first made for open drains, the farmer following the meanderings of slight depressions and later making branch ditches to parts of fields which most needed draining. As his circumstances or opportunity permitted, branch drains were laid from time to time through the lowest ground, so we find very few instances in Madison County where drains have been placed at regular intervals.

Some of the first underdrainage was accomplished by "timber ditches," which were made by digging trenches 1 to 2 feet wide, in which timber 6 to 8 inches wide was placed on each side and covered by slabs, usually rived from elm trees, laid crosswise, and then the earth backfilled over them. This made an underdrain 6 to 8 inches deep and 8 to 20 inches wide. Such drains are reported to have done good service and lasted many years.

No material advancement in the drainage of swamp lands was made until drain tile came into general use. A description of the drainage of a few of the farms will give an insight into the character of the improvement, the present location of the drains, and the results which may be attributed to the drainage of the area involved.

#### ELLSWORTH FARM.

This is a farm of 80 acres situated 4 miles west and 2.5 miles north of Summitville. Its surface is quite level, there being no more than 3 or 4 feet difference in the extremes of elevation. The soil is made up of about 6 or 8 inches of vegetable mold, which is quite permeable to water, below which is a stratum of bluish clay which, before being underdrained, is close and tenacious and through which water percolates slowly. It is seriously injured if cultivated while wet and requires some time and subsequent treatment to restore it to its best condition. After being drained, however, the subsoil becomes quite permeable and, with cultivation sufficiently deep to mix the subsoil with the surface, it becomes very productive.

The first effort toward the drainage of this farm was to construct an open drain diagonally across the north half of the tract 3 feet in depth and 10 feet wide on the top (fig. 123). Tributary drains of 5 and 6 inch tile, laid approximately 20 rods apart, were discharged into this ditch. Lateral branches of 4-inch tile were used to complete the drainage. The sizes of tile used were suggested to the owner by observation and experience in draining other lands.

No records were kept of the work, and information only approximately correct can be obtained. No survey was made, the tile being laid by water level about 30 inches deep upon grades approximately 0.1 to 0.2 foot per 100 feet. Ditches were dug by hand and the bot-

toms were finished with the draw scoop. The drainage on this farm was done when labor was cheap, so that the cost for trenching and laying was 15 to 20 cents per rod, and tile were at least 25 per cent less than list prices now quoted by factories. It is noted that the quality of the crops was greatly improved and the quantity about doubled; also that malarial diseases, which were very prevalent before drainage, have entirely disappeared. The owner suggests that better results would have been obtained by making the drains deeper and laying the laterals not over 10 rods apart. The land was purchased in 1882 at \$18.125 per acre. After draining, as described, and one crop being raised the land was rated at \$35 per acre, or about double the original cost.

The open ditches first used as outlets for the drainage of this farm had slight fall, perhaps not greater than 0.08 foot per 100 feet. The water flowed with sluggish cur-

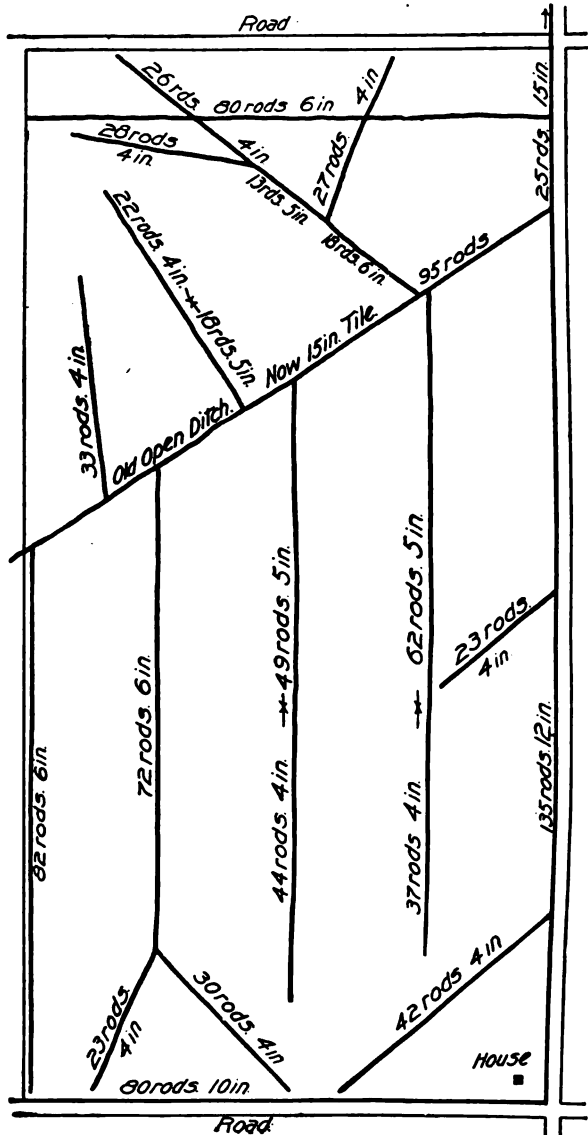

FIG. 123.—Ellsworth farm.

rent and the channels were easily obstructed by growing weeds which retained silt, so that the outlets to the tile were in many cases covered with earth and their efficiency impaired. During the past two years large tile have been substituted for the open ditches, the largest being

15-inch, which were placed at an average depth of 4.5 feet or 1.5 feet deeper than the open channels. The size used was necessary, because of the area of land lying above the drains through this course. The entire farm can now be cultivated.

While no record was kept of the grades, it is probable that the line of 15-inch tile was laid on a grade of 0.04 to 0.06 foot per 100 feet and the smaller tile on slightly increased grades. No tile drains have been taken up, the later lines having in all cases followed the general direction of the old open ditches. The farm yields large crops of corn, oats, and rye, to which the land seems to be adapted. It is now considered worth \$100 per acre.

#### LUKIN, THOMAS, MATTHEWS, COREY, AND DAVIS FARMS.

The conditions of these farms as to soil, topography, drainage, and crops are similar to those of the Ellsworth farm just described. The land is slightly rolling, diversified by swales and ridges forming pockets which collect the rainfall. With the exception of the ridges, where spots of white clay occur, the soil is generally a bur oak or black loam. The subsoil of the black lands permits the ready passage of water, while that of the clay lands is tenacious, requiring drains at frequent intervals. Five, 6, and sometimes 8 inch tile are used as mains and submains, and the lateral drains are 4-inch tile.

With regard to the size of main drains, Mr. Davis, a tile manufacturer, of Madison County, says that an 8-inch tile will drain 80 acres, a 12-inch 200 acres, and a 15-inch 500 acres. Aside from such rules as these, no method of estimating the size of drains appears to have been used. The farmers have usually followed the plan of adding lines of 4-inch tile year by year as needed. If the drainage proved insufficient, another line of 4-inch tile was laid a few rods distant. In some instances lines of tile were laid only in the swales, while in others a systematic arrangement of 4-inch laterals at intervals of 2 to 3 rods in clay soil and 6 to 8 rods in black soil was followed.

Concerning the depth at which tile should be laid, there seems to be some difference of opinion. Some owners of the farms here noted advocate the laying of tile 4 feet deep, while others contend that 30 inches is sufficient. It is also claimed that tile may be laid deeper in clay land than is generally practiced, for though the land may not drain so well during the first year after construction, it has been found that the tile will operate satisfactorily after two or three years, since the soil becomes more open and aerated by the action of the drains. It is said that drains 4 feet deep may be laid twice as far apart as those 2.5 to 3 feet deep. This "rule of thumb" method is followed by the farmers in this locality to a considerable extent.

As a rule, no grade was established before laying the tile. The ordinary method followed was to begin at the outlet and use the flow

of the water in the trench as a guide in preparing the bottom of the ditch. On this account most farm tiling was and is yet done in the spring, when there is an abundance of water. Some of the lines are apparently laid almost on a level, as the head of water in the soil is considered sufficient to cause a flow.

Few records of the cost of the work can be obtained, as it was mostly done by the farmers themselves, who have kept no accounts.

The drainage of these farms has made a better method of cultivation possible and permitted an intelligent rotation of crops to be followed, which was not the case before the entire farm was fitted for cultivation. It is commonly asserted that crops have been doubled and even trebled by these improvements, instances being given in which the yield of corn per acre has been increased from 25 to 80 bushels. Of course a part of this increase may be attributed to

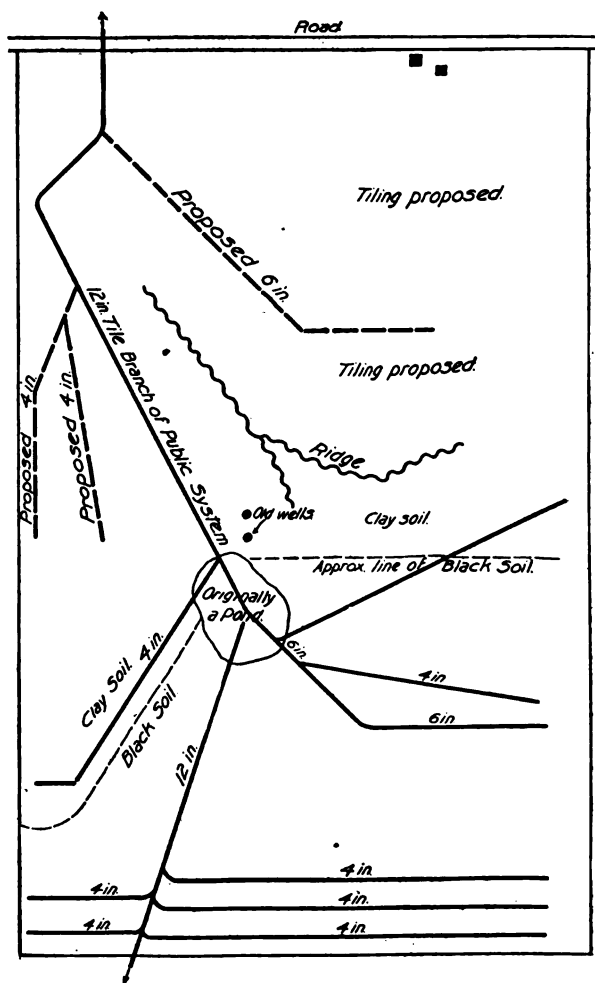

FIG. 124.—Lukin farm.

better methods of farming and the use of proper fertilizers. Not among the least of the benefits may be mentioned the increased healthiness of the community, everyone consulted stating that fevers and ague, which prevailed previous to the drainage of the lands, are now unknown.

*Lukin farm.*—The farm of Mr. Lukin contains 100 acres and was in some respects quite difficult to drain because of a large flat or pond

near its center. The first attempt at drainage was made near the center of the farm, at which place two large wells were dug into the gravel stratum, which lies 6 to 7 feet below the surface, and lined with brick (fig. 124). Several lines of tile were discharged into

these wells, the water passing through the gravel, which served as an excellent outlet except during the spring months, when it failed to operate satisfactorily because the water was delivered into the wells faster than the gravel could remove it.

During the year 1904 the owner succeeded in getting a county tile drain through his farm, which affords him a good outlet, and he now proposes to drain his place thoroughly. The plat represents what has been done to the present time, and also the work proposed. In designing the system the owner has followed the local practice, and proposes to lay his tile 2 to 3 rods apart in clay soil and 6 to 8 rods apart in the more porous, black soil.

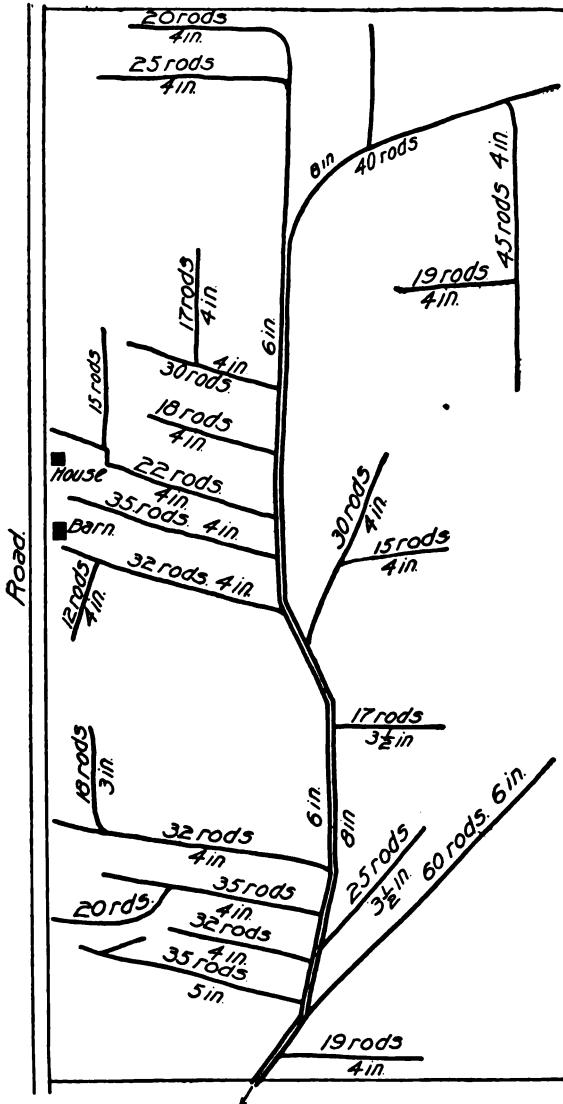

FIG. 125.—Thomas farm.

The depth of drains is about 30 inches in clay and a few inches deeper in the black soil.

*Thomas farm.*—The Thomas farm of 120 acres, located 3 miles east of Pendleton, is slightly rolling and, like the one previously described, has a soil of black loam, with some spots where a tough white clay is

found. The present owner has been identified with its drainage since 1871. Wooden drains 4 to 5 inches high and 12 to 15 inches wide inside, built of split timber and laid without bottom, were first used (fig. 125). Nothing is known of the method of laying these drains except that they were 18 to 24 inches below the surface. They were used because earthen pipe was at that time difficult to get and costly. When tile could be obtained at a reasonable price a 6-inch main was laid through the center of the swale, as shown upon the plat. Each succeeding year a string of tile was added. The owner soon found his 6-inch main too small and supplemented it by an 8-inch tile, which he laid by the side of the first drain. Some farmers object to laying two lines of tiling close together, as, in some instances, the water forms a channel between them and undermines the tile. No trouble, however, has been experienced with these drains. Nearly all the laterals are 4 inches in diameter and laid where most needed, usually through surface depressions. Marked success has attended

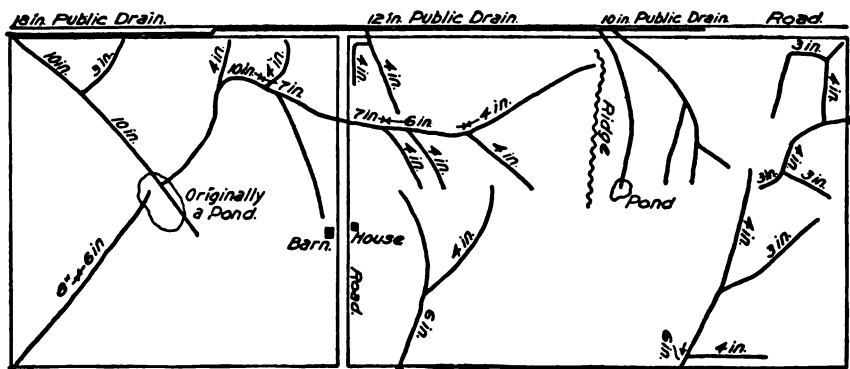

FIG. 126.—Matthews farm.

the tiling of wet clay spots, which, when drained, can be plowed the day following any ordinary rainfall. The depth at which tile were laid in this farm varies from 18 inches to 6 feet, though 30 inches is regarded as the standard.

The owner did the work with the assistance of his farm help, locating the lines as his experience year by year suggested, and grading the ditches by the water method. Neither the exact location of the drains nor the cost of the work is known. It is learned that the first lot of 4-inch tile used cost 80 cents per rod, which is at least double current prices.

*Matthews farm.*—The Matthews farm of 120 acres, lying about 6 miles northeast of Anderson, up to fifteen years ago had no drainage except a small open ditch extending from a pond to the public road (fig. 126). The farm is generally quite level with the exception of a knoll in the center, upon which the buildings are located. The soil



is the usual black oak loam interspersed with spots of clay, the subsoil being tenacious and wet, except when artificially drained.

The work has been done entirely by the owner, no system being followed except to lay lines of tile from time to time where the ground appeared to be wet. No record of the work has been kept, the plat here given showing only such particulars as could be described by the owner from memory. On the east side the work is unfinished, but elsewhere the farm is drained to the satisfaction of the owner.

*Corey farm.*—Mr. Corey, near Anderson, has drained his land more systematically than many. His experience in tiling several farms indicated to him that tile were usually of too small size and laid too shallow. In revising his drainage plans he gives no attention to existing lines, but locates the drains as systematically as possible. He has tile laid upon hillsides and also upon the top of the hill land. In clay soils he lays his lines 2 to 3 rods apart, but in the black loam the intervals are 8 rods or more. He advocates laying the lines as deep as 3 feet in clay and deeper in black soil.

*Davis farm.*—Mr. Davis, a tile manufacturer located southwest of Anderson, owns a farm of 200 acres, most of which is systematically drained. In clay land he places the lines at intervals of 2 to 3 rods, and in black land 7 to 8 rods. His practice is to locate the lines irrespective of the swales, which sometimes necessitates placing the drains at a depth of 9 to 10 feet.

#### MIAMI COUNTY.

The farm of Andrew J. Phelps, consisting of 160 acres, is located 1.5 miles east of Bennetts Switch. The surface is slightly rolling. The soil is black, underlaid with quite permeable clay, and is injured greatly if worked when wet. The original drains, which were put in about 1875, were made of timber and placed in lines 16 to 25 rods apart (fig. 127). The general depth is 30 inches, though in some cases a depth of 7 feet is reached in passing through ridges. The grades varied from  $\frac{1}{4}$  to 3 inches per rod. The size of tile used upon this land varied from 4 to 8 inches. The plat shows the general arrangement of the drains. No accurate account of the cost was obtainable.

#### HOWARD COUNTY.

The George Ehrman farm, of 160 acres, located 7 miles west of Kokomo, is reported upon quite fully by the county surveyor (fig. 128). The soil is black sandy loam, 18 to 24 inches deep, underlaid with clay. It was formerly covered with timber, the sugar tree, black walnut, and poplar being the prevailing kinds. As in other farms described, the drains are placed about 30 inches deep, and on

this farm nearly all discharge into natural outlets. They are reported as giving good service. It is noted that the grades are all good, varying from 2 to 3 inches per 100 feet. The usual price paid

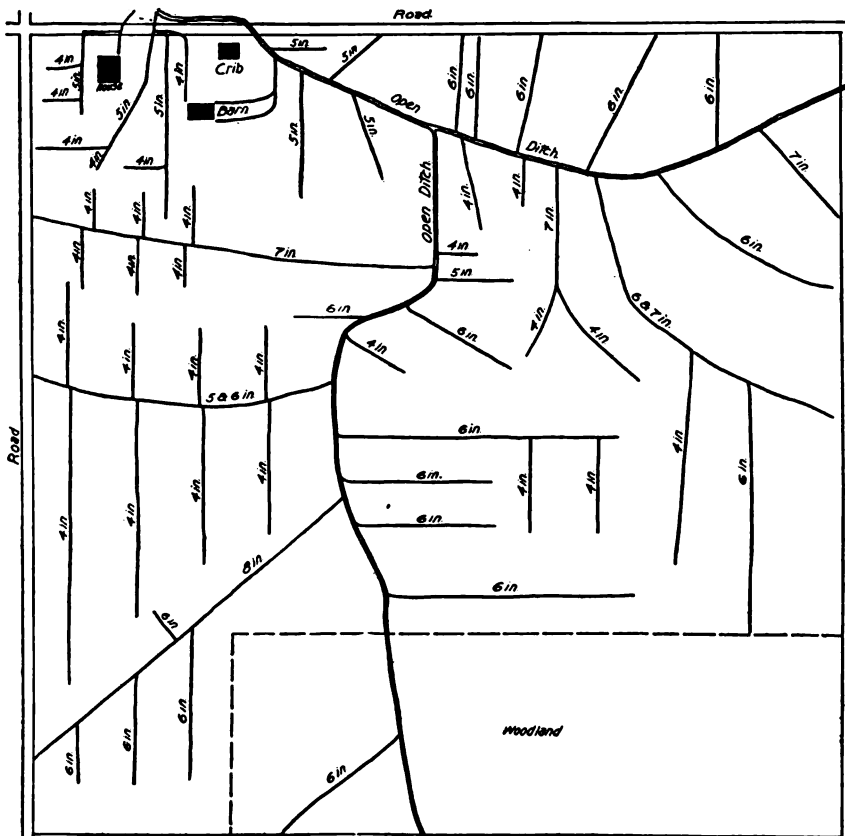

FIG. 127.—Phelps farm.

for excavating the ditches and laying and covering the tile was about 25 cents per rod. The cost of the tile used was as follows:

	Cents per rod.
3½-inch .....	16
4-inch .....	20
5-inch .....	25
6-inch .....	30
7-inch .....	40

The report upon the effect of the drains says that the soil is made more porous, permitting it to dry more readily after heavy rainfall and affording better aeration. In dry weather a greater amount of moisture is retained, the effect of which is to increase the usual corn crop in a wet season about 50 per cent and in a dry season about

25 per cent. The effect upon the land for wheat growing is more marked, since drainage prevents the heaving out and consequent destruction of the plants.

No drains have been taken up and relaid, all seeming to now operate satisfactorily. It is noticed that malaria, which was formerly

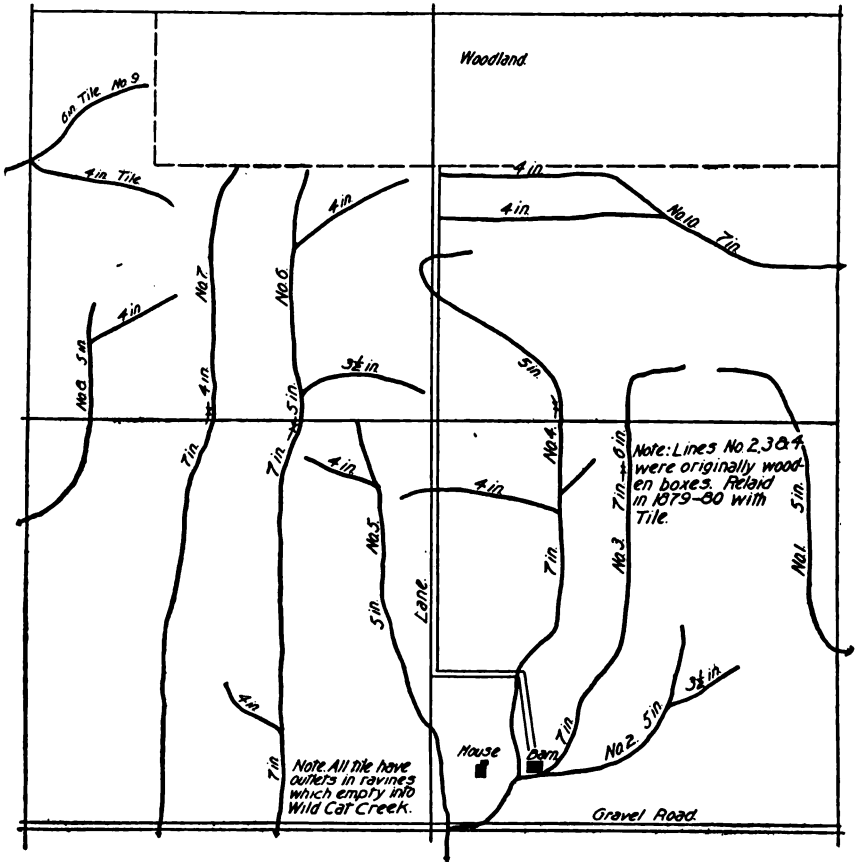

FIG. 128.—George Ehrman farm.

prevalent, has disappeared and there is a marked improvement in the healthiness of the locality, as instanced by the fewer cases of typhoid and other diseases.

The following table is given by Mr. William A. Ehrman, county surveyor, for determining the sizes of tile for drainage in this vicinity, laid upon different grades:

*Size of tiles for different grades.*

Size of tile.	Grade per 100 feet.	Area drained.	Size of tile.	Grade per 100 feet.	Area drained.
<i>Inches.</i>	<i>Foot.</i>	<i>Acres.</i>	<i>Inches.</i>	<i>Foot.</i>	<i>Acres.</i>
4	0.15	23	6	0.15	62
4	.20	28	6	.20	72
4	.25	29	6	.25	80
5	.15	40	7	.15	92
5	.20	48	7	.20	106
5	.25	50	7	.25	128

**TIPTON COUNTY.**

The Bennett farm, consisting of 40 acres, 6 miles west of Sharpsville, has been satisfactorily drained at quite small expense (fig. 129).

The soil is 10 to 14 inches deep, underlaid with heavy clay. The first drains were made by placing split rails 10 to 15 feet long in the bottom of trenches and covering the rails with slabs. The drain tile first used were 2.5 and 3 inches in diameter and were laid only 18 to 24 inches deep. Later larger tile were used and were laid at a depth of

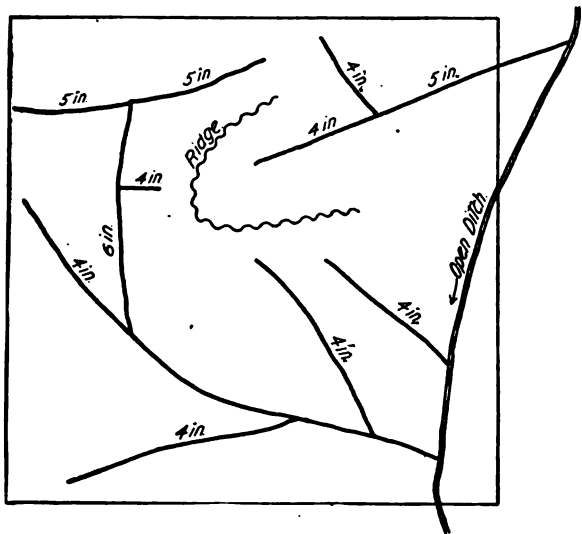

FIG. 129.—Bennett farm.

40 inches. The owner has attended to all of the draining personally and has located the lines where in his judgment they were needed. The grades are 1 to 3 inches per 100 feet. Drainage has cost about 1 cent per rod for each inch of depth, and hauling, laying, and filling about 5 cents per rod. The land which he bought for \$25 an acre is now valued at \$95. He estimates that the drainage, aside from other improvements, has enhanced the value of the farm fully one-half.

**COMMENTS.**

An examination of the tile drainage of Indiana farms herein described brings out the manner in which the work was ordinarily accomplished in the earlier development of the improvement. Attention may be profitably directed to a few of the characteristics which appear.

The black loam soil is open and consequently easy to drain, so that it has not been found necessary to place the lines of tile at frequent intervals except where the surface soil is quite largely composed of clay. The plan generally followed has consisted in placing the drain tile where open ditches were first made, and supplementing these by lines of tile through the wet places. The surplus water readily passes through the soil to these drains with the assistance of such few laterals as have been used, thus reducing the number of lines to the minimum. The distance between laterals where they are in parallel lines appears to be no less than 12 rods, while it is not uncommon to find drains 24 rods apart.

The presence of a clay subsoil at a depth of 24 inches or less, in such sharp contrast to the top soil, has led to the placing of drains 30 inches deep, except where greater depth was necessary to obtain sufficient grade. The upper line of the tile is just below the level of the permeable soil, and at this depth they appear to render efficient service, though it should be noted that experiments with deeper drains have given satisfactory results.

The size of the drains used is perhaps the most variable feature of the work. While the farms are, in the estimation of the owners, satisfactorily drained, it is readily seen that as far as the size of tile is concerned, unnecessary expense has been incurred on some of the farms, provided all are equally well drained. In one instance it is noted that on the same farm 6-inch tile is used on one part for the drainage of 2 acres, while in another part the same size serves 20 acres. But little difference in size is noted between the drains laid upon light and upon heavy grades, lines having been added until the land was drained to the satisfaction of the owner. It is noticed that the sizes of pipes used for mains and submains are far larger than those suggested in the table of Mr. Ehrman, surveyor of Howard County (see p. 741). Even with careful work in location and construction it is doubtful if the sizes suggested will meet the requirements of drainage for field crops except where relief by supplementary drains is provided. However, later practice elsewhere may be cited to show that where grades are carefully adjusted and followed in construction, the size of drains may be considerably diminished without affecting their efficiency. As examples of the sizes of outlets or their equivalents used on some of the farms described, the following may be mentioned:

- 40 acres, one 9-inch tile.
- 80 acres, one 10-inch and one 9-inch tile.
- 80 acres, one 9-inch tile.
- 80 acres, two 10-inch tiles.
- 160 acres, four 9-inch tiles.
- 160 acres, one 6-inch and one 8-inch tile.

The farm which has the largest drainage outlet capacity per acre has drains laid on the steepest grade, so that it is quite evident that there is much room for modifications in the size of drains were the work to be done in accordance with our present knowledge of such matters.

The lack of facts regarding the cost of these improvements, as well as lack of method in constructing the drains, might be expected in the instances described, especially since the work was largely one of experiment from year to year.



# INDEX.

	Page		Page
Abbeville rice irrigation plant .....	539-540	Backwater, drainage in bottom land .....	665
Adams ditch, branches, etc.....	257-260	Barley, duty of water measurements.....	31
Frank, on distribution and use of		return per acre under irrigation....	33
water in California.....	98-139	Bartlett, William Francis, on Idaho irriga-	
Alfalfa, duty of water in New Mexico...	303-308	tion.....	279-302
measurements .....	31, 261-263	Basin method of irrigation .....	52, 82
growing, irrigation practices .....	265-266	Bear River canal, Utah, irrigation .....	26, 37
under irrigation .....	293-295	Bearing, fruit, influence of irrigation....	148-151
irrigating season and water used..	32,	Beets, sugar, duty of water measurements .	32
294, 308-311		effect of irrigation.....	579-580
irrigation .....	593, 615	irrigation.....	593, 619-623
effect on yield .....	583	Colorado .....	609-614
with pump water, cost. 308-311		return under irrigation.....	33
returns per acre under irrigation..	33	Beeville Experiment Station, Texas, crops,	
yields in irrigation experiments. 307-308		etc.....	404-406
Alkali in irrigation work .....	86, 187, 653	Berries, irrigation .....	594
western Texas, relation to rain-		Bog, cranberry. See Cranberry.	
fall .....	339-340	floating, in cranberry reservoirs ....	639-640
Almo Creek, Idaho, irrigation ...	280, 282-283, 290	Bogs, peat, management .....	721, 722
Water Company, claims and status. 286-289		Bonds, irrigation, sales, etc .....	99, 100, 522
Almond, bearing under irrigation .....	150	Bottom lands, Mississippi River, drainage,	
Analyses, beet, Kansas and Colorado .....	580	etc.....	676-691
soil, Oregon .....	264-265	South Dakota, drainage	
water in rice irrigation .....	69, 70	plans .....	658-667
Oregon.....	264-265	Bowie, Aug. J., jr., on irrigation, southern	
Analysis, creek water, Santa Clara Valley.		Texas.....	347-507
Cal .....	85-87	Breaker, construction for clearing land....	272
Anderson, James, on peat moss quotation. 719-721		Burnham, A. E., on cherry irrigation in	
Ankeny ditch, Oregon, losses of water.....	37,	California .....	145
260, 262		Cabbage, irrigation.....	594
Apples, irrigation in California, profit.....	147	effect on yield .....	573
Oregon, profit .....	144	Calexico Cattle Company, ranch, crop data.	193
Aquatic vegetation, clogging of canals....	193-194	California canals, duty of water measure-	
Arid region, irrigated fruit, shipping		ments .....	25
quality .....	158-161	seepage and evaporation .....	36
Arizona canals, seepage and evaporation..	36	cost and duty of water under	
duty of water measurements ..	25, 30-32	sixty pumping plants .....	87-90
fruit, irrigated, exhibition.....	171	Development Company, organi-	
shipping quality .....	161	zation, capital.....	181-182
Arkansas, irrigation pumping.....	56	Development Company, work in	
prairie land, rice irrigation....	545-565	Imperial Valley .....	179-184
rice growing, introduction .....	72	duty of water measurements on	
irrigation, 1904, pumping		farms.....	30
plants .....	559-565	farming in San Joaquin Valley,	
River, conditions at Garden City,		change .....	135-136
Kans .....	585	fruit and vegetable pack by va-	
Artesian districts, southern Texas.....	355-356	rieties.....	164
wells, cost, capacity, etc.....	488, 502-501	irrigated, drying.....	166-169
irrigation in Texas.....	55-56, 58	exhibition at fairs .....	170
notes .....	373-501	irrigation .....	148-151
Pecos, Tex., irrigation ...	323-324	quality, effect of irrigation. 153	
Texas, southern, location		Imperial Valley, irrigation ....	175-194
and description .....	502-504		
Atlantic coast, marsh reclamation ....	25, 714, 717		



	Page.		Page.
California irrigated fruit, canning	162-166	Conduits, concrete construction	72
shipping quality	159-161	water, southern Texas	368-372
irrigation in fruit growing	144-147	wooden	368
laws and customs	66, 67, 68	pipe	370
pumping	53-54, 58	Congress, action as to irrigation and drainage investigations	19
Santa Clara Valley	77-92	Contract form, land and water lease	395, 400
Modesto and Turlock Irrigation districts, use of water	98-139	Cooperation, Department and State stations	19
pumping plants and pumps, tests	195-255	Cooperative work in several States	20, 21
Canal, cemented, freedom from water losses	28	Corn, Colorado, need of irrigation	117
records, forms	136-139	duty of water measurements	31
system, Imperial Valley, Cal.	181	irrigation, effect on yield	574, 582-583
Canals, California, losses of water	38	with pump water, cost	313-314, 315
Modesto and Turlock	104	New Mexico, irrigation	54
drainage, for Gulf rice fields	518	returns per acre under irrigation	33
duty of water measurements	25-30	Texas, growing, note	350
large, for irrigation, pumping plants	535	Corpus Christi, water supply	411-414
losses of water	35-38	Cotton industry, Texas	349-350
seepage and evaporation losses	36	southwest Louisiana, planting	515
Canning irrigated fruits	162-165	Texas, cost of growing	350
Cantaloupe irrigation, remarks	614-615	Cranberry, composition, notes	627
Carrizo Springs, Tex., irrigation plants	458-469	effect of lime on growth	636
lakes	457	growing, conditions necessary	626-627
Carson, A. H., apple irrigation in Oregon, remarks	144	irrigation, community reservoirs	640
Cattle industry, Texas	349	discussion	73-75
Centrifugal pumps, tests	233-240	ditches, size and management	641-642
Chamberlain, E. J., testimony, Sny Island levee construction	688-691	loss by evaporation	639-640
Check irrigation, preparation of land	120-123	marshes, Wisconsin, irrigation and drainage	625-642
method, application of water	52, 118-120, 262, 305	reservoirs, floating bog	639-640
Cherry, irrigation in California, profit	145	Crawfish, injury to levees	697
"Circle" in levee mending, definition	699	Creeks, Texas, southern, use in irrigation	382-384
Citrus trees, irrigation in California	146, 147	Creosote, use in preserving piles in Mermentau dam	521
Clay, relation to swamp lands	722, 723, 727, 730	Crevasses, Mississippi River levee	701-703
subsoil, relation to irrigation, remarks	145	Crop production in Texas under irrigation	333-334
Clear Creek, Idaho, irrigation	297-299	returns, irrigation, notes	33, 34-118, 258, 307-308, 310, 311, 313, 314, 326, 327, 333, 350, 351, 400, 428, 483-484, 579-583, 593, 594, 680
Clearing land for irrigation	268-272	southern Texas, average per acre	483
Climate, Imperial Valley, Cal., records	177	Crops, drained land	713-714
(See also Precipitation and Temperature.)		duty of water measurements	31-35
Coal Creek levee and drainage district	672-674, 710	southern Texas	482
fuel for pumping	56, 60	irrigated compared with unirrigated, returns	573-574
Texas, cost and fuel value	365-368	Modesto and Turlock districts, California	116-118
Collins, A. B., and A. E. Wright, on irrigation, 1904, Kansas	585-594	on irrigated ranch	198
Colorado canals, duty of water measurements	26	quality as affected by irrigation	142
seepage and evaporation	36	returns under irrigation	373-501
irrigation pumping	57-58	rice yields	72, 73, 558
Platte River, return seepage	47, 48	Texas	55
pumping plants for irrigation	595-603	water requirements	22
return seepage, St. Vrain Creek	45	Crowder, irrigation, implement, construction	190
River, appropriation of water	180-181	Crowley, La., duty of water, 1904	581
flood and effect in Salton Sink	176-177	Culbertson, Harvey, on irrigation studies in western Texas	319-340
irrigation by pumping	328-329		
Rocky Ford, 1904, irrigation	609-623		
small pumping plants for irrigation	616-623		
South Platte, return seepage	40		
water-right laws and customs	64, 65, 66		
Concho River, Tex., irrigation	325-329		
Concrete construction, water conduits	372		

	Page.		Page.
Culverts, levee, in bottom-land reclamation, notes.....	706-707	Duty of water, Eagle Lake, Tex.....	527-529
Current wheels, use in irrigation, notes.....	390	estimates .....	111
Dakota, South. (See South Dakota.)		gravity ditches, California....	82-85
Dams, construction, etc., notes .....	104-105	Gulf rice irrigation, 1904....	529-533
cranberry irrigation, location and construction .....	636-638	in Montana.....	303-315
storage, building, for irrigation....	337-338	Louisiana, Estherwood.....	526
Texas, discussion.....	542-543	measurements.....	25-35
water storage, southern Texas.....	357	for alfalfa.....	261-263
Dancy district, Wisconsin, drainage problems.....	724-728	on Washington canals....	273-278
Del Rio Irrigation Company, canal.....	424-427	note.....	614
Desert-land entries, California.....	179	pumping plants.....	87-91
Dew Point table, cranberry district, Wisconsin.....	631	Raft Creek, Idaho.....	292-295
Distribution, water.....	129-135, 279	rate per acre, southern Texas....	483
Idaho law.....	67, 283	rice irrigation measurements.....	69
Ditches and pumping plants, cost of water..	90-91	southern Texas.....	482
choking with vegetation.....	193-194	under gravity ditches.....	82-85
drainage, in sandy lands, construction, etc.....	657-658	1904, under 60 pumping plants.....	87-90
irrigation, discussion.....	641-642	Eagle Lake, Tex., duty of water, 1903....	527-529
size and cost for bottom-land drainage .....	663-665	Earth tanks, storage of irrigation water....	339
Diversified farming.....	564	El Paso, Tex., irrigation.....	321-322
Dodge, H. P., testimony in Sny Island bond suit.....	687-688	Electric motors, pumping plants.....	213-226, 243
Drag, construction for clearing land of sage brush.....	271	Elliott, C. G., report of drainage investigations, 1904 .....	643-743
Drainage, bottom land, on Missouri in South Dakota.....	658-667	Engine. (See Pumping plants.)	
districts, Illinois and Wabash rivers .....	669-676	Erosion, hillside, farm lands.....	728-731
ditches, cleaning and construction.....	656, 670	Estherwood, La., duty of water, 1903 and 1904.....	526-527, 530
dredged, cleaning.....	656-657	Evaporation, irrigation losses, 1904, Lonoke, Ark.....	558
sandy land, construction and maintenance....	657-658	loss in cranberry irrigation....	638, 639-640
Florida Everglades.....	714-717	losses from canals.....	96
frost protection to Wisconsin cranberries .....	633-635	Oregon ditches.....	259, 263
"hill water".....	703	of water from cranberry marshes .....	74
Indiana.....	731-743	record at Fort Hays, Kans.....	572, 573-579
investigations, 1904, report .....	643-743	rice irrigation.....	534
lack, injury to fruit .....	172	Texas.....	320
laws, State.....	666	Everglades, Florida, soil formation, drainage problems.....	714-717
Mississippi River bottom land reclamation .....	703-713	Experiment, rice irrigation in Arkansas....	547
overflowed lands.....	703-713	Experiments, duty of water in Montana..	303-315
peat bog.....	721	irrigation, 1903 and 1904, Fort Hays, Kans .....	567-568
pipes.....	705-707	Farm lands, hillside erosion.....	728-731
relief of injury by irrigation.....	277	Farmer, irrigation, most profitable use of water.....	35
remedy for alkali in Texas, need.....	339-349	Farming, California, San Joaquin Valley, change.....	135-136
rice field, on Gulf .....	517-518	diversified, remarks.....	564-565
systems, plans .....	726-727	methods, rice growing on the Gulf.....	514-516
use in frost protection.....	627-635	Farms, duty of water measurements.....	30
Utah.....	652-656	Feed, rice products.....	543
wells.....	656	Fertilizer, value of peat, investigation.....	721
Wisconsin cranberry marshes....	625-642	Fertilizers, cranberry.....	626
Drains, construction.....	654	Fertilizing value creek water, Santa Clara Valley, Cal .....	85-87
Drill, use in planting rice .....	555	Field tests, pumping plants .....	196-231, 243
Drying irrigated fruits .....	165-169	Fig, Calimyrna, planting.....	117
Duty of water, alfalfa, New Mexico .....	303-308		
average for main canals .....	27, 28		

	Page.		Page.
Flint Creek, Iowa River levee, history and illustrations .....	680-682, 711	Furrow method of irrigation .....	52, 81-82
Flood waters, storage, in western Texas..	335-337	Furrows, irrigation, devices for distributing water .....	610-613
Flooding, protection of cranberries in frost.	635	Garden crops, irrigation .....	594
Floods, Texas, danger to irrigation dams..	542	Gasoline engines, use for irrigation pumping .....	199-213, 243
Florida Everglades, soil formation, drainage problems .....	714-717	fuel for irrigation work..	53, 55, 56, 59, 60
Flumes, wooden, use in Texas .....	639	pumping plants, Texas, tests .....	476
Ford, I., irrigation of apples, statement....	147	George Creek, Idaho, irrigation .....	296-297
Forecasting, weather, relation to cranberry growing .....	628	Georgia, experiment hillside drainage...	729-731
Fortier, S., on irrigation in Santa Clara Valley, Cal. ....	77-92	Gillet, Felix, irrigation of pears, effect on quality .....	154
Frio River, Tex., irrigation plants .....	447-457	Grain, irrigation experiment, California..	118, 615
Frost, formation, influence of humidity .	630-631	Gravity ditches, California, duty of water and losses .....	82-85
local influences .....	628	Gregory, W. B., on rice irrigation, Louisiana and Texas .....	509-544
prevention, means .....	631-635	Ground water, influence of pumping ...	587-588
protection by drainage .....	633-635	level, Florida Everglades...	716
irrigation, drainage, and sanding .....	627-635	movement .....	725
Fruits, bearing, influence of irrigation..	148-151	records .....	126-129, 645-652
deciduous, California pack by varieties .....	164	Guadalupe River, Tex., irrigation plants.	373-390
drying, fundamental propositions.	165-166	Haney, J. G., on irrigation experiments, Fort Hays, Kans. ....	567-583
flavor, effect of irrigation .....	152	Haywood, J. K., letter on water analyses...	70-71
growing, carelessness, etc., in irrigation .....	171	Head of water, definition of term .....	497
growing, Modesto and Turlock districts, Cal. ....	117-118	Hillside farm lands, erosion .....	728-731
irrigated, canning .....	162-165	Honduras rice, notes .....	555, 558
drying .....	165-169	Hops, duty of water measurements .....	30, 32
exhibition at fairs .....	169-171	Humid section, irrigation, discussion .....	68-75
injury by lack of cultivation .....	172	Humidity, influence on frost formation..	630-631
quality and commercial character .....	151-158	Hydrants in irrigation, construction .....	473
shipment .....	158-161	Ice, cause of break in levees .....	704
irrigation .....	593	Idaho, canal, seepage and irrigation .....	86
productivity, influence of irrigation .....	142-147	duty of water measurements ...	80, 31, 32
ripening, injury by irrigation .....	173	Raft River .....	292, 295
seasons and methods of irrigation..	79, 80	fruit, irrigated, drying .....	166
shipping qualities .....	156-161	exhibition at fairs..	169
size, quality, etc., relation of irrigation .....	141-174	irrigation .....	148
Fuel, available, southern Texas .....	364-368	quality, effect of irrigation..	152
cost for pumping water for irrigation .....	56, 59-60	irrigated fruit, shipping quality....	159
gasoline, advantages .....	497	fruits, canning .....	162
and oil, use in irrigation pumping .....	329	irrigation, George Creek .....	296, 297
excessive cost .....	491, 495, 496	in fruit growing .....	143
irrigation pumping, notes .....	381-501	Raft River conditions, 1904 .....	279-302
oil and gasoline, comparative cost ...	541	Raft River water-right needs .....	299-302
gasoline and wood, in irrigation.	331-332	water-right laws and customs .....	67
pumping plant for irrigation in Texas .....	341-346	water rights on Raft River .....	280-281
for irrigation, notes .....	595-608	Illinois drainage ditches .....	656
plants, cost, value, efficiency .....	491, 493, 506-507	peat lands .....	722
gasoline and oil .....	199-213, 227, 229, 230	River, levee and drainage districts .....	668-675
Fuels for pumping .....	542	Imperial Valley, Cal., description, climate, waterways .....	175-178
		irrigation .....	175-194
		water companies, organization, workings, etc.	183-185
		Implements for leveling land .....	189-191
		Indiana, black, peaty soils, management..	722
		pioneer drainage .....	731
		tile drainage .....	731-743
		Interstate questions in irrigation .....	295-299

Page.	Page
Irrigation, act of 1897.....	97
application of water at one irri- gation.....	613
beet, advisability of night work.....	620
and cantaloupe, compari- son.....	621
average cost.....	620
rapidity of work.....	619, 620
check, preparation of land.....	120-126
1904, Colorado, Rocky Ford.....	609-623
conditions, Imperial Valley, Cal.....	175-194
cranberry, in Wisconsin.....	73-75
damage, relief by drainage.....	277
ditches, choking with aquatic vegetation.....	193-194
discussion.....	641-642
effect on flavor of fruit.....	152
experiment methods in New Mexico.....	305-308
experiments, 1903 and 1904, Fort Hays, Kans.....	567-583
fruit, injuries.....	171-174
Garden City, Kans., 1904.....	585-594
value of crops.....	593-594
humid section, discussion.....	24, 68-75
Idaho, George Creek.....	296, 297
Raft River conditions, 1904.....	279-332
interstate questions.....	295-299
labor and cost.....	483
laws, Idaho, relation to water master.....	281-289
mechanical tests of pumps and pumping plants.....	195-255
methods.....	479-481
of preparing land.....	50-51
western Texas, discus- sion.....	334-335
New Mexico, Mesilla Park, 1904 studies.....	303-317
Oregon, Klamath County.....	257-266
plants and pumps, southern Texas, tests.....	474-478
southern Texas, detailed description.....	373-474
tests.....	474-478
Porto Rico, remarks.....	75
preparation of land.....	22, 50-51
price of water, Klamath County, Oreg.....	257
review of 1904 work.....	19-96
rice, in Louisiana, Texas, and Arkansas.....	68-73
Louisiana and Texas, 1903 and 1904.....	509-544
on Arkansas prairie.....	545-565
Santa Clara Valley, Cal.....	77-92
season, remarks.....	32, 328
southern Texas.....	347-507
time and labor, details for beets.....	613-614
use in frost protection.....	627-635
Washington, Yakima Valley, 1904 study.....	267-278
Irrigation water, profitable use.....	35
requirements for beets and cantaloupes.....	621-622
western Texas.....	319-340
cost.....	329-331
winter and summer, Fort Hays, Kans.....	576-577
Wisconsin, cranberry marshes.....	625-642
work 1904, review.....	19-75
Irrigators, Idaho attitude toward water master.....	285
Japan rice, notes.....	556, 558
Johnson grass, notes.....	326, 327
Johnson, Prof. S. W., investigation of peat as fertilizer.....	721
Kafir corn, irrigation, effect on yield.....	582
notes.....	193, 582
Kansas, Fort Hays, 1903 and 1904, irrigation experiments.....	567-583
Garden City, 1904, irrigation.....	585-594
irrigation pumping.....	57
pumping plants for irrigation.....	605
Kent, F. L., on irrigation, Klamath County, Oreg.....	257-266
Labor and cost of irrigating southern Texas. conditions, southern Texas.....	483 372-373
Laboratory, centrifugal pumps.....	233-240
description.....	231
tests, pumping plants.....	230-255
triplex pumps.....	240-242
Lacey levee and drainage district.....	670-672, 702
Land, irrigation, cost of preparation.....	268-279
preparation.....	50-51
leveling, methods, implements.....	189-191
railroad, Texas, southern, develop- ment.....	418
southern Texas, uses, acreage.....	349-351
Lands, overflowed, reclamation.....	667-714
Langford, F. M., alfalfa growing under irri- gation.....	293-295
Laramie River, return seepage.....	49
Lateral ditch companies, Colorado.....	615-616
Laterals, distributing, Tuolumne River, Cal., canals.....	125
irrigation, devices for distributing water.....	610-613
method of constructing.....	192
system of naming.....	181
Law, irrigation and drainage investiga- tions, text.....	19
Idaho.....	67, 281-289
Louisiana, in aid of rice irrigation....	522
Mexican, on corporations.....	179
Laws, irrigation, discussion.....	24, 63-68
Le Conte, J. N., on mechanical tests of pumps, etc.....	195-255
Legislation. See Law.	
Levee construction.....	691-696
length, nature, cost, different districts.....	709-712

# 750 IRRIGATION AND DRAINAGE INVESTIGATIONS, 1904.

	Page		Page
Levee district, Mermentau, tax provisions, etc.....	522	Muskrats, damage to levees.....	696
drainage .....	703-708	Mutual water companies, California, organization, etc.....	182-186
embankments, use as road .....	698	notes .....	68, 180
failures, causes .....	700-703	Nebraska canals, duty of water measurements.....	26
maintenance .....	696-700	duty of water measurements....	30
protection in overflow .....	691	Platte River, return seepage....	48
repairing, materials .....	699	pumping plants, abandoned....	606-608
Levees, construction .....	123-125, 554, 691-696	for irrigation. 603-606	
damages by animals .....	696, 697, 698	South Platte, return seepage....	40
failures, causes .....	700-703	water-right laws and customs .....	64, 66, 66
Illinois and Wabash rivers.....	668-676	Nevada, duty of water measurements .....	31, 32
Mississippi River.....	676-691	New Mexico, duty of water for alfalfa .....	303-308
patrolling and inspection.....	698	measurements. 30	
rice field, on Gulf, uses .....	514	Experiment Station, irrigation studies, 1904 .....	303-317
Leveler, irrigation, construction .....	190	Experiment Station, meteorology .....	316
Leveling land, methods, implements....	189-191	irrigation pumping .....	54
Levels, location, importance of care in dam building.....	636, 637	New River, Cal., measurements of flow .....	178
Lifts, pumped water .....	58, 59	Nottoway, Tex., duty of water, 1904.....	532
Lime, effect on the cranberry .....	636	Nueces River, irrigation.....	444, 447
Llano River, Tex., irrigation .....	325, 327-328	plants .....	411-415
Louisiana, irrigation pumping.....	56, 58	Oats, duty of water measurements .....	32
rice irrigation, 1903 and 1904..	509-544	returns per acre under irrigation .....	33
Malaria, reduction by drainage .....	740	Oil engines, use for irrigation pumping..	199-213
Mangel-wurzels, irrigation, effect on yield.	573	rice, value and use .....	548
Marsh lands, Wisconsin, drainage problems, discussion .....	718-728	use as fuel in irrigation pumping .....	366-368
Marshes, cranberry, flooding.....	74-75	Olwell Brothers, apple irrigation in Oregon.	144
Wisconsin, irrigation and drainage.....	625-642	Onion culture .....	483-484
Meadow, duty of water measurements....	32	Onions, Bermuda, Texas. 351, 430-435, 459-462, 473	
Meadows, water, formation in marsh lands.	721	duty of water measurements .....	372
Mechanical tests, irrigation pumping plants .....	195-255	irrigation .....	593
Meredocia levee and drainage district. 677-678, 710		Oranges, irrigation in California .....	30, 146
Mermentau dam, rice irrigation on Gulf. 519-524		Orchard age, relation to need of irrigation..	150
Mesquite, use as fuel in irrigation pumping .....	364-366	duty of water measurements .....	31
Meteorological conditions, New Mexico ..	316	irrigating season and water used..	32
relation to cranberry growing .....	628	irrigation, California, seasons and methods .....	79-82
Mexican law on corporations .....	179	returns per acre under irrigation..	33
Miller-Morris rice-irrigation plant .....	537-539	(See also Fruit and Fruits, etc.)	
Mills, J. W., irrigation of almonds, remarks.	150	Oregon fruit, irrigated, canning .....	162
Mississippi River flats, system of drainage .....	676-691	drying.....	166
Missouri River Valley, S. Dak., drainage. 658-667		exhibition at fairs. 170	
Modesto and Turlock irrigation districts, California, distribution and use of water .....	93-139	quality .....	153
irrigation system, construction... 99		shipping quality ..	159
Montana, canals, seepage and evaporation. 37		irrigation .....	143, 148
duty of water measurements.. 26, 31, 32		Klamath County, irrigation .....	257-266
laws, note .....	68	Overflowed lands, reclamation.....	667-714
Moors, cranberry. (See Marsh.)		Peaches, bearing under irrigation.....	149
Moss, peat, effect on soil.....	720	duty of water measurements .....	32
Motors, irrigation pumping, notes .....	373-501	irrigation in California, benefit ..	145, 146, 147
plant, notes. 199-255		Pearsall, Tex., irrigation plants.....	469-474
Muck lands, drainage, discussion.....	719-728	Peas, duty of water measurements.....	31
Muscatine Island levee and irrigation system .....	678-680	Peat, adaptation to cranberry growing... 626-627	
		beds, cultivation .....	722
		bogs, drainage, discussion.....	719-724

	Page.
Peat in Pennsylvania, Indiana, Illinois..	722-723
lands, drainage and management..	718-728
moss, effect on soil .....	720
value as fertilizer, investigation .....	721
Pecos River, Tex., irrigation .....	322-325
Valley irrigation .....	324-325
Pekin-Lamarsh levee and drainage system.	666-667, 709
Pencillaria, irrigation, effect on yield.....	582
Pennsylvania State Experiment Station report on peats .....	722
Pierce, J. M., on alfalfa growing under irrigation .....	293-295
Piles, use in making dams on Mermentau River.....	519-521
Pipe, wooden, cost, use in Texas.....	370, 371
Pits, pump, in Texas irrigation .....	341-346
Planer, irrigation, construction.....	190
Platte River, return seepage .....	38-48
South, seepage return .....	38
<i>Pongatia zeylanicum.</i> (See Waterweed.)	
Porto Rico, irrigation, remarks .....	76
Potatoes, duty of water measurements.....	31
irrigating season and water used .....	32
irrigation, effect on yield .....	573
effects and cost .....	581-582
returns per acre under irrigation .....	33
(See also Sweet potatoes.)	
Power, pumping plant .....	341-346
for irrigation,	
notes .....	595-608
use of steam in irrigation .....	552
Prairie land, Arkansas, rice irrigation .	72, 545-565
Wood River, irrigation.....	258
Precipitation, Abilene, Tex., table.....	321
Klamath Falls, Oreg.....	259
monthly and annual, southern Texas .....	347, 348, 349
Texas .....	319
(See also Rainfall.)	
Price, Judge, decree on Raft River, Idaho, water.....	285-286
Priorities, recognition.....	65
Prune, irrigation, advantage.....	77, 144
Pump water, application .....	81
irrigation of alfalfa, cost... ..	308-311
corn, cost.....	313-314
sweet potatoes, cost.....	315
wheat, cost... ..	311-313
wells, Texas, southern, location and description.....	505-506
Pumping, cost.....	251-255, 376, 493-502, 709-712
engine, historic examples .....	585
fuel cost in irrigation .....	59-60
irrigation, cost in Arkansas .....	72-73
equipment in New Mexico.....	304
investigations.....	62-63
use of windmill for power .....	338
plant, cost, details.....	562-563
Fort Hays, Kans., changes .....	575-576

	Page.
Pumping plants, abandoned, Nebraska irrigation .....	605-608
and ditches, comparison of cost of water.....	90-91
capacity, fuel, etc..	490-493, 506
Colorado .....	595-603
Nebraska, and Kansas .....	595-608
electric motors .....	213-226
engines, selection.....	536
field tests .....	196-230
gasoline and oil .....	199-213
irrigation, western Texas, list .....	332
Kansas .....	605-608
laboratory tests.....	230-255
Nebraska .....	603-606
rice irrigation, 1904, Arkansas.....	559-665
rice irrigation on Gulf. 584-542 Santa Clara Valley, Cal., cost and duty of water. 87-90 small, for irrigation .....	616-623
rice irrigation .....	540-541
steam engines .....	226-230
tests, western Texas .....	330-331
Texas.....	341-346
two large, Louisiana, results .....	537-540
rice irrigation .....	557, 559-565
semi-arid region, study.....	23-24, 52-63
tests, Kansas.....	587-588
Pumps and irrigation plants, southern Texas, tests .....	474-478
pumping plants for irrigation, tests.....	195-255
centrifugal, use.....	327
economical operation in irrigation .....	331-332
irrigation, tests .....	474-478
mechanical tests in California.....	195-255
pitless and with pits, for irrigation in Texas .....	341-346
prices, for irrigation in Texas.....	346
rotary, use .....	707
testing .....	196-198, 474-478
use in Arkansas prairie, irrigation, drainage .....	545-565
707-708	
Raft River, Idaho, Almo Water Company, claims.....	287-289
duty of water.....	292-295
interstate questions in irrigation .....	295-299
irrigation conditions .....	279-302
water right needs.....	299-302
supply .....	289-292
Railroads, southern Texas.....	351
Railway embankment, use as part of levee.	698
Rain. (See Precipitation.)	
Rainfall, Fort Hays, Kans.....	572, 578-579
Lonoke, Ark., 1904, table .....	558
Modesto, Cal .....	107
relief from salt in Gulf rice fields.	518

	Page.		Page.
Rainfall, Santa Clara Valley .....	78	Roadhouse, J. E., on irrigation in Imperial Valley, Cal .....	175-194
Texas.....	347-349	Roads, drive, use of levee embankments...	698
and Louisiana, 1903 and 1904 seasons .....	509-514	Sagebrush, clearing land for irrigation...	269, 270
western Texas, relation to irrigation.....	319-321	Salt water, effect on rice growing in field..	578
Wisconsin, and evaporation, table.....	639	Mermentau River, menace to rice crop.....	519-520
Rake for clearing land, construction.....	271	relation to rice irrigation.....	69-71
Reclamation, attempts at Imperial, Cal....	179-180	Salton Sink (Imperial Valley), Cal.—	
overflowed lands .....	667-714	natural waterways .....	177-178
works, nature and cost .....	709-712	situation, topography, and climate.....	175-177
Reed, J. H., irrigation injuries to fruit, remarks .....	174	Salts, quantity in irrigation water, Louisiana .....	512
Reservoir construction .....	404, 484-488	San Antonio, early irrigation .....	384
cranberry irrigation, depth of water .....	638	irrigation in vicinity .....	389-402
dam, cranberry irrigation, location.....	636-637	River, irrigation .....	399-402
storage for irrigation, size, etc. ....	337, 338	sewage .....	396-399
Reservoirs, community systems .....	640	waterworks .....	384, 389
cranberry irrigation, effect of vegetation .....	639-640	wells and irrigation plants. ....	386-402
evaporation .....	638-639	San Saba River, Tex., irrigation .....	327
influence on return seepage....	44	Sand hills, Monahans, Tex., note .....	325
irrigation, sizes.....	62	in drainage ditches.....	657-658
storage .....	357, 422, 444, 446, 458, 484-488	relation to levee construction, notes. ....	700-703
Return seepage, Laramie, South Platte, etc. ....	23, 38-50, 66, 267	Sanding, use in frost protection .....	627-635
Rice experiment, Arkansas, details .....	547-558	Sandy soil, cause of levee failures.....	700-703
stations.....	547-555	Santa Clara Valley, Cal., description, products, advantages.....	77-92
flooding, in Gulf State farming .....	514, 515	Santa Clara Valley, Cal., irrigation.....	77-92
growing, early Arkansas experiments .....	545-547	pumping .....	53
Gulf, 1903 and 1904 seasons. ....	509-514	pumping tests .....	195
Louisiana, law in aid .....	522	water supply and orchard irrigation .....	78-82
injury by salt water.....	578	Scraper, land-leveling, advantages and use .....	189, 191-192
irrigation, Arkansas.....	545-565	Seeding alfalfa, Oregon .....	265
duty of water, rainfall, and evaporation .....	527, 529, 531, 532, 533, 534	Seepage, canal losses .....	23, 35-38
Louisiana .....	509	cause of levee failure .....	702
and Texas.....	68-73, 509-544	conditions of soil in Imperial Valley, Cal .....	186-187
on Arkansas prairie .....	545-565	injury to lands .....	24
small plants compared with large, note .....	524-526	losses from canals .....	36
Texas .....	509	Oregon ditches .....	259-261
water measurements, four years.....	533-534	in Washington .....	268
late and early, comparative irrigation, notes .....	524, 525	Modesto Canal, Cal.....	115-116
planting, watering and harvesting in Arkansas .....	555-559	measurements in Imperial Valley, Cal .....	186-189
polished, food value.....	513	Raft River, Idaho .....	291-292
stock feed, use in Gulf States .....	516	return, discussion .....	38-50
straw, uses present and suggested.....	544	water, rise .....	646
unpolished, food value superior to polished rice .....	543	Semiarid regions, water, underground, etc. ....	24, 52-63, 195-255, 341-507
varieties and yields, 1904, Lonoke, Ark. ....	558	Sewage, San Antonio.....	396-399
Japan and Honduras merits. ....	517	Shipment, fruit, relation of irrigation.....	158-161
Rio Grande Valley, Tex., irrigation.....	423-444	Shovels, steam, use in irrigation work, cost, etc.....	425
Riparian rights, recognition.....	65	Siphons, inverted steel, use in irrigation....	106
Ripening fruit, injury by irrigation.....	173	Sny Island levee and drainage district.....	684-691, 712
Rivers, southern Texas.....	352	maps .....	685, 686
		Soil, Acadia Parish, character .....	526
		analyses, Oregon .....	264-265

	Page.
Soil, characteristics, Indiana.....	732, 734, 738, 742
composition, Wisconsin swamp lands.	727
conditions in Imperial Valley, Cal..	186-189
cranberry .....	626
Eagle Lake, Tex., character .....	527
effect of peat moss .....	720
New Mexico Experiment Station, quality.....	312, 314
under irrigation.....	304
rice, in Texas, note .....	516
Texas, southern.....	352
water, fluctuations in level at Fresno, Cal.....	648-652
Yakima, Wash .....	272
Solls, Indiana, notes.....	731-743
peat, drainage and management... ..	718-728
Texas, southern, notes .....	373-501
Washington, several under irrigation.....	275-278
Soil-water wells .....	656
Sorghum, irrigation, effect on yield.....	198, 582
South Dakota, ditch systems.....	663-665
drainage laws.....	666
of bottom lands .....	658-667
Missouri River.....	658-667
Southern Texas. (See Texas, southern.)	
Springs, southern Texas .....	356, 384
Staked Plains irrigation possibilities.....	339
Steam engines, irrigation plants .....	498
pumping plants.....	226-230
pumping plants, tests, etc. . . . .	53, 226, 243, 477
shovels, use in irrigation work, cost, etc.....	425
Storage dams, building, for irrigation....	337-338
Texas, discussion.....	542-543
flood water, in Texas irrigation .....	335-337
irrigation water for Wisconsin cranberries.....	635-641
Stout, O. V. P., on pumping plants in Colorado, Nebraska, and Kansas.....	595-608
Strainers, pumping, for irrigation....	341-343, 358
use in Arkansas prairie irrigation.....	545-565
wells .....	358-361
Strawberries, duty of water measurements.	32
Sugar beet. (See Beet.)	
Summer irrigation, Fort Hays, Kans.....	577
Surveys, cost, etc. ....	661
Swamp lands, Indiana, drainage and management (see also Marsh lands) .....	724, 731-743
Sweet potatoes, irrigation .....	593
with pump water, cost... ..	54, 315, 326, 327
Tait, C. E., on pumping plants in Texas..	341-346
rice irrigation on Arkansas prairie.....	545-565
Taxation, levee.....	71, 522
Teele, R. P., review of irrigation work, 1901.	19-75
Temperature, cranberry region, Wisconsin.	629
effect of sanding .....	632
injury to fruit under irrigation.....	172
monthly averages, Klamath Falls, Oreg.....	259

	Page.
Temperature, records, California, Imperial.	177
relation of irrigation and drainage.....	73-74
well water, relation to irrigation.....	316-317
Terraces, prevention of erosion, methods of laying out.....	728-729
Test wells for measurement of ground water.....	645
Tests, mechanical, pumps and pumping plants for irrigation .....	195-255
pumping plant and pump.. ..	53, 330, 474-478
Texas, crop production, statements .....	333-334
early irrigation San Antonio.....	384
irrigation plants near Cuero .....	373-377
Victoria .....	377-384
pumping .....	54, 68
Katy, pumping plants of W. J. Alderson .....	341-342
pumping plants for irrigation.....	341-346
rainfall .....	347-349
rice irrigation .....	509
San Antonio, ranches.....	389-402
southern, artesian and pumped wells, tables.....	502-506
crops, average value per acre .....	483
dams, water storage .....	357
duty of water .....	482
fuel, cost and value....	364-368
industries, crops, railroads, general features.....	349-352
irrigation.....	347-507
plants, detailed description. . . . .	373-474
labor conditions.....	372
water conduits in use... ..	368-372
water supply .....	352-357
western, drainage and irrigation. . . . .	319-340
Tile drainage for hillsides .....	729-731
Indiana farms, cost, increase in value of land .....	731-743
Tiles, drain, cost of different sizes.....	739
size for different grades.....	741
Timber, Mermentau dam, creosote treatment .....	521
Timothy, irrigation, notes.....	30, 295
Tomatoes, duty of water measurements....	32
Topography, South Dakota bottom lands. . .	661
Texas, southern .....	351-352
Tuolumne River, irrigation .....	108, 109
water rights of irrigation districts.....	102-104
Turlock and Modesto irrigation districts, California, distribution and use of water.....	93-139
canal, duty of water; losses.....	25, 38
irrigation district .....	66-67
system, construction... ..	98-99
Underground water, supply at Garden City, Kans .....	586-588, 589
Upland rice, note.....	558
Utah, alkali lands.....	654
drainage.....	652-656



754 IRRIGATION AND DRAINAGE INVESTIGATIONS, 1904.

	Page.
Utah drainage ditches, construction .....	654
duty of water measurements ..	25, 26, 31, 32
Raft River water rights.....	296-299
Uvalde water works.....	449
Vegetable pack, California, by varieties....	164
Vegetation; aquatic, choking of irrigation ditches .....	193-194
Vernon, J. J., on irrigation in New Mexico, 1904.....	303-317
Wabash River levees .....	675-676
Waller, O. L., on irrigation study, Washington, 1904.....	267-278
Walnut, English, irrigation in California, benefit.....	146
Warsaw-Quincy levee system, illustrations.....	682-684, 712
Washington canals, duty of water measurements.....	273-278
duty of water measurements ..	26
30, 31, 32	
fruit, irrigated, canning .....	162
drying .....	166
exhibition at fairs.....	170
quality.....	153
shipping quality.....	159
irrigation .....	143, 148
Yakima Valley, irrigation, 1904 study .....	267-278
Water, analyses, Oregon.....	115, 264-265, 512
application, check method .....	118-126
in irrigation, methods. 51-52	
to land, methods ..	22, 51-52
commissioners and masters, provisions .....	281-282
companies, Imperial .....	183-186
mutual, Cal., organization, etc .....	182-186
conduits in use, southern Texas ..	368-372
control and division, conditions..	279-281
cranberry irrigation, depth in reservoir .....	638
distribution .....	129
and use, Modesto and Turlock districts, Cal. 93-139	
duty. (See Duty of water.)	
ground, records.....	645-652
"head," definition .....	447
irrigation, injury to fruit.....	171
profitable use .....	35
kind and source for cranberry irrigation.....	636-637
losses from canals.....	35-38
prevention in irrigation, notes ..	35
master, difficulties with measuring devices .....	282-283
Idaho, duties .....	281-289
meadows, establishment in marsh lands .....	721
methods of application .....	118-126
quantity applied at one irrigation..	613
rice irrigation, analyses .....	69, 70

	Page.
Water rights, California Development Company, cost of stock.....	184
Idaho, Raft River.....	279-281
disputes. 285-289	
Imperial Valley, Cal., contract between companies. 182-183	
irrigation systems, from Tuolumne River.....	102-104
Platte River, discussion .....	63-66
Raft River, discussion ..	280, 295-299
salt, effect on rice in field.....	518
(See Salt water.)	
sources in South Dakota bottom lands .....	661-663
supply, Corpus Christi .....	411-414
earth tanks .....	392, 393
irrigation, storage and management.....	635-641
Raft River, Idaho, discussion .....	289-292
southern Texas .....	352-357
table, Fresno, Cal., fluctuation ....	648-652
titles, Idaho, decrees .....	285
relation to water master.....	281-289
Tuolumne River, Cal., quality.....	114-115
use.....	111-115
underground, apparent supply, Garden City, Kans... 586-588	
rate of flow.....	41
supply on Staked Plains .....	339
use in rice irrigation on Gulf.....	524-526
well, application in irrigation.....	81-82
works, San Antonio.....	384, 389
Watermelons, duty of water measurements. 32	
Water-right contracts .....	182-183
deeds.....	102
Waterways, Imperial Valley, Cal.....	177-178
Waterweed, rice-field pest on Gulf.....	516-517
Weather forecasting, cranberry region... 627-628	
relation to irrigation.....	578, 627
Weed, strange, appearance in Gulf rice fields .....	516-517
Weeds, control by water .....	514, 515
Well, irrigation, at Fort Hays, Kans., cost details.....	570
level of water, measurements.....	499
strainers.....	356-361
water supply for rice irrigation .....	72
temperature, relation to irrigation .....	316-317
Wells, artesian, cost, capacity, etc.... 488, 502-504	
Pecos, Tex., irrigation... 323-324	
southern Texas.....	381,
384, 385, 416-423	
boring, Texas, method and cost....	357-
364, 388	
depth.....	56
ground water, records of rise.....	126-129
irrigation, Colorado, Nebraska, and Kansas.....	595-608
cost .....	344, 570
soil water .....	656

	Page.		Page.
Wells, irrigation, water supply, methods of		Winter irrigation for beets .....	609
use .....	81-82	Fort Hays, Kans.....	576-577
pumped, cost and output.....	489, 506-506	Winterhalter, W. K., beet irrigation report.	
southern Texas.....	354-355, 502-507		618-623
test, measurement of ground water,		Wisconsin, cranberry irrigation .....	73-75
description .....	645	marshes, irrigation	
use in Arkansas prairie irrigation..	545-565	and drainage....	625-642
Wheat, California, decline in production..	96	Experiment Station, notes ...	628, 631
irrigating season and water used...	32	marsh lands.....	718-728
irrigation with pump water, cost.	311-313	University, study of the cran-	
returns per acre under irrigation...	38	berry .....	625-626
yields under irrigation in New Mex-		Wood, fuel for pumping.....	56, 60
ico.....	313	Wooden flumes and pipe, use in irrigation.	369-372
Wheaton dam and ditch, Cal., history.....	102	Worms, infestation of Gulf rice fields, note.	515
Whitson, A. R., on irrigation and drainage		Wright, A. E., and A. B. Collins, on irriga-	
of Wisconsin cranberry marshes .....	625-642	tion, 1904, in Kansas ....	585-594
Wickson, E. J., article on relation of irriga-		on irrigation in 1904 at Rocky	
tion to fruit growing .....	141-174	Ford, Colo .....	609-623
Windmill irrigation, Garden City.....	589-594	law, irrigation districts, passage	
plant, cost .....	591-592	and repeal.....	96, 97
power for irrigation pumping..	338-339	Wyoming, duty of water measurements.	26-27, 30
pumping capacity, tables.....	590	Platte River, return seepage....	49, 50
Windmills, use in irrigation, Texas .....	389	water-right laws and customs.	64, 65, 66
pumping irrigation water	61-63	Yakima River, Wash., irrigation .....	267-278
Winter irrigation.....	53, 78, 80		

10/10

8



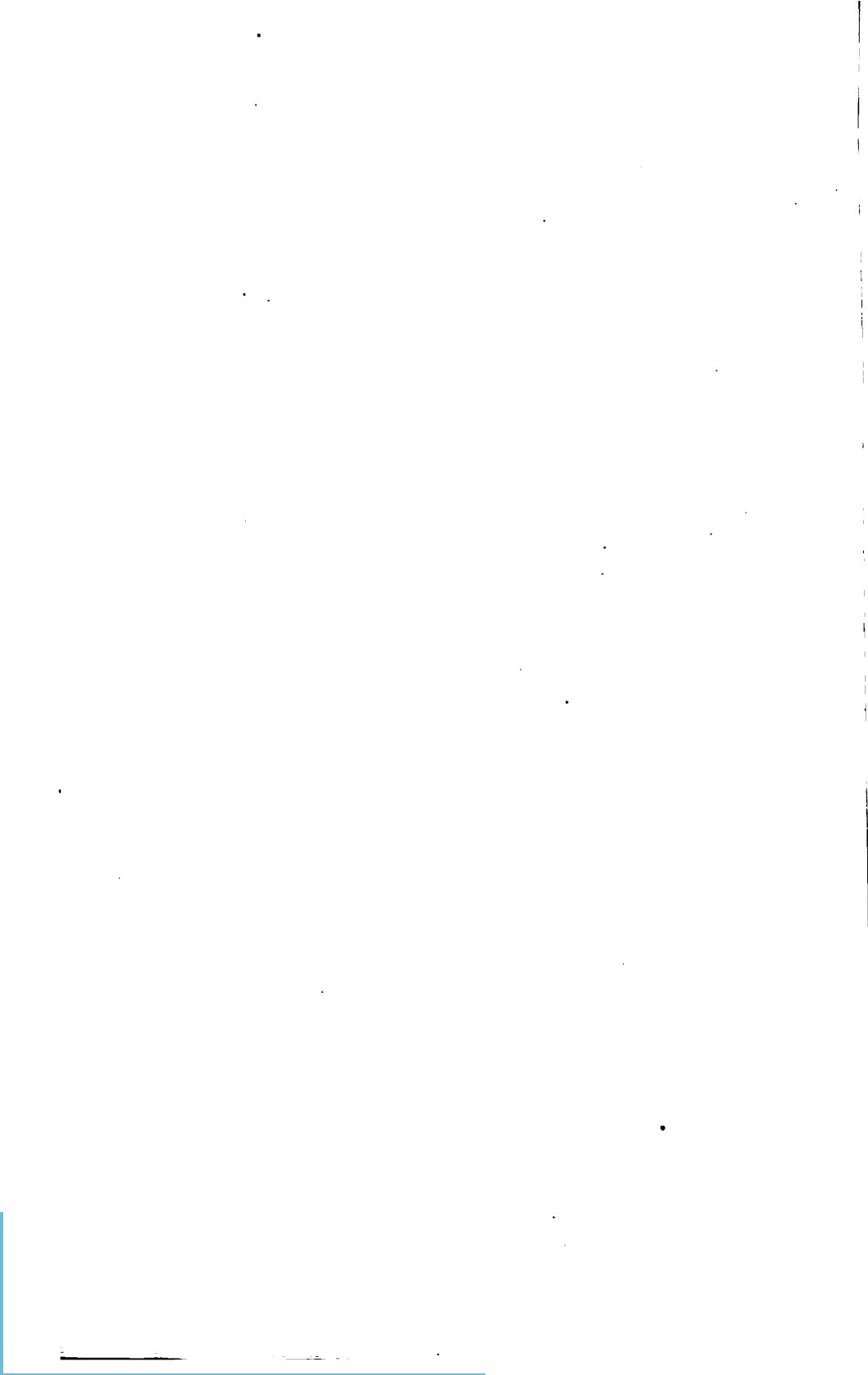



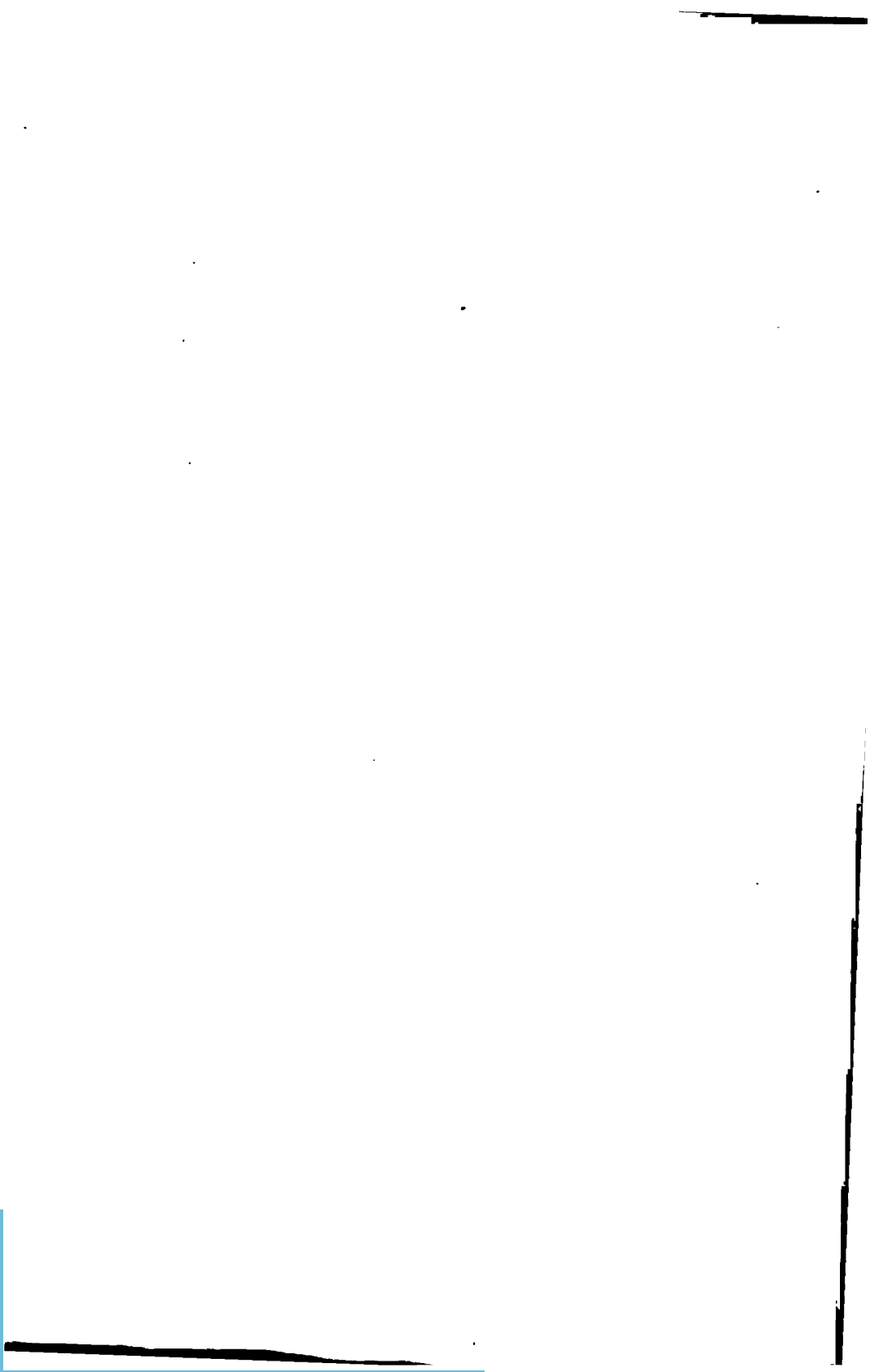





LIBRARY OF CONGRESS

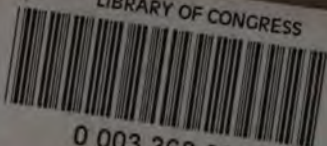

0 003 368 038 7

